



Download  
Manual



Growatt New Energy

Shenzhen Growatt New Energy Co., Ltd  
4-13/F, BuildingA, Sino-German (Europe) IndustrialPark,  
HangchengAve, Bao'anDistrict, Shenzhen, China

**T** +86 755 2747 1942  
**E** service@ginverter.com  
**W** www.ginverter.com

GR-UM-299-A-02



## WIT 50-100K Storage/Hybrid Inverter User Manual

# Contents

<b>1 Notes on this manual</b> .....	<b>1</b>
1.1 Introduction .....	1
1.2 Target Group .....	1
1.3 Product Range.....	1
<b>2 Safety Precautions</b> .....	<b>2</b>
2.1 Safety Instructions .....	2
2.2 Symbol Conventions .....	3
2.3 Label Description.....	4
<b>3 Product Description</b> .....	<b>5</b>
3.1 Overview .....	5
3.2 Basic Data .....	8
3.3 Nameplate .....	9
3.4 Operating Principle .....	10
3.4.1 Operating Principle of WIT 50-100K-A .....	10
3.4.2 Operating Principle of WIT 50-100K-H .....	10
3.4.3 Operating Principle of WIT 50-100K-AE and WIT 50-100K-AU .....	11
3.4.4 Operating Principle of WIT 50-100K-HE and WIT 50-100K-HU .....	11
3.5 Storing the WIT Inverter .....	12
3.6 Supported Grid Types .....	12
3.7 AFCI Function .....	12
3.7.1 AFIC function description .....	12
3.7.2 Clearing the alarm .....	13
3.8 Anti-PID Function .....	13
<b>4 Inspection upon delivery</b> .....	<b>14</b>
<b>5 Installation</b> .....	<b>16</b>
5.1 Basic Installation Requirements.....	16
5.2 Installation Environment Requirements .....	17
5.3 Moving the WIT Inverter.....	18
5.4 Mounting the WIT Inverter .....	19
5.4.1 Ground-mounted Installation.....	19
5.4.2 Wall-mounted Installation .....	20
<b>6 Electrical Connection</b> .....	<b>22</b>
6.1 Connecting the Ground Cables.....	26
6.2 Connection on the AC Side.....	27
6.3 Connection on the PV Side .....	30

6.4 Connection on the Battery Side .....	32
6.4.1 Connecting the Main Power Cable of the Battery.....	32
6.4.2 Connecting the Battery BMS-AC Terminal.....	33
6.5 Connecting Communication Cables .....	34
6.5.1 Battery Communication Connection .....	35
6.5.2 External Communication Connection .....	36
6.5.3 Parallel Communication Connection.....	38
6.5.4 Monitoring Device Terminal.....	41
6.5.5 DRMS Port .....	41
6.6 Post-installation Checks .....	43
<b>7 Commissioning.....</b>	<b>45</b>
7.1 Powering on/off the System .....	45
7.2 Commissioning the WIT Inverter .....	46
7.2.1 Set the Communication Address.....	46
7.2.2 Set the Time and Date .....	46
7.3 Mode of operation .....	47
7.3.1 Waiting Mode .....	47
7.3.2 Operating Mode .....	47
7.3.3 Fault Mode .....	48
7.3.4 Shutdown Mode .....	48
7.4 LED and OLED Display Panel .....	49
<b>8 Monitoring.....</b>	<b>52</b>
8.1 Remote Monitoring .....	52
8.1.1 Remote Monitoring on the APP (ShinePhone).....	52
8.1.2 Remote Monitoring on the ShineServer Webpage .....	68
<b>9 System Maintenance.....</b>	<b>89</b>
9.1 Routine Maintenance.....	89
9.1.1 Clean the Chassis.....	89
9.1.2 Fan Maintenance .....	89
9.2 Troubleshooting.....	91
9.2.1 Warning.....	91
9.2.2 Error .....	96
<b>10 Product specifications.....</b>	<b>102</b>
Table 10.1 WIT 50/63/75/100K-A specification .....	102
Table 10.2 WIT 50/63/75/100K-H specification .....	105
Table 10.3 WIT 50/63/75/100K-AE specification.....	109

Table 10.4 WIT 50/63/75/100K-HEspecification.....	112
Table 10.5 WIT 50/63/75/100K-AU specification .....	116
Table 10.6 WIT 50/63/75/100K-HU specification .....	119
<b>11 Decommissioning the WIT Inverter .....</b>	<b>123</b>
<b>12 Warranty .....</b>	<b>124</b>
12.1 Conditions .....	124
12.2 Disclaimer.....	124
<b>13 Contact Us.....</b>	<b>125</b>

# 1 Notes on this manual

## 1.1 Introduction

This manual is intended to introduce the WIT 50-100K Storage/Hybrid Inverters manufactured by Shenzhen Growatt New Energy Co., Ltd. (hereinafter referred to as Growatt) in terms of their installation, operation, commissioning, maintenance and troubleshooting. Please read this manual carefully before using the product, and keep it in a convenient place for future reference. The content of this manual is continually reviewed and amended, where necessary. Growatt reserves the right to make changes to the material at any time and without notice.

### Note:

"WIT" refers to the product name and "50-100K" indicates the power classes. The WIT series comprises both Storage Inverter models and Hybrid Inverter models.

## 1.2 Target Group

This document is intended for qualified technicians. Only qualified and well-trained technicians are allowed to install and operate the WIT inverter. Should any questions arise during installation, you can visit [www.growatt.com](http://www.growatt.com) to leave a message, or call our 24-hour service hotline at +86 755 2747 1942.

## 1.3 Product Range

The WIT 50-100K (380V/400V) Storage/Hybrid inverters consist of six models, each offering four power classes: 50kW, 63kW, 75kW, and 100kW. In total, there are 24 products in this series. This manual is valid for the following models:

Table 1.1 WIT 50-100K Storage/Hybrid inverter

WIT 50K-A	Three-phase Storage Inverter	WIT 50K-H	Three-phase Hybrid Inverter
WIT 63K-A		WIT 63K-H	
WIT 75K-A		WIT 75K-H	
WIT 100K-A		WIT 100K-H	
WIT 50K-AE	Three-phase Storage Inverter with EPS function	WIT 50K-HE	Three-phase Hybrid Inverter with EPS function
WIT 63K-AE		WIT 63K-HE	
WIT 75K-AE		WIT 75K-HE	
WIT 100K-AE		WIT 100K-HE	
WIT 50K-AU	Three-phase Storage Inverter with UPS function	WIT 50K-HU	Three-phase Hybrid Inverter with UPS function
WIT 63K-AU		WIT 63K-HU	
WIT 75K-AU		WIT 75K-HU	
WIT 100K-AU		WIT 100K-HU	

# Safety Precautions 2



## 2.1 Safety Instructions

- 1) Please read this manual carefully before installation. Damages caused by failure to follow the instructions in the manual are beyond the warranty scope.
- 2) Only qualified and trained electrical technicians are allowed to perform operations on the WIT Inverter.
- 3) During installation, please do not touch other parts inside the equipment other than the wiring terminals.
- 4) Ensure that all electrical connections comply with local electrical standards.
- 5) Only designated personnel are permitted to perform maintenance on the inverter.
- 6) Before operating the WIT Inverter in on-grid mode, ensure that you have obtained any permission needed from the local grid operator.

### Transportation:

 <b>WARNING</b>	<ul style="list-style-type: none"> <li>• Risk of injury when lifting the WIT Inverter or due to a falling inverter, as it is heavy. Please transport and lift the inverter with caution.</li> </ul>
---	---

### Installation:



 <b>NOTICE</b>	<ul style="list-style-type: none"> <li>• Please read this manual carefully before installation. Damages caused by failure to observe instructions specified in this manual are not covered under any warranty.</li> </ul>
 <b>DANGER</b>	<ul style="list-style-type: none"> <li>• Do not connect any cables before installation.</li> </ul>
 <b>WARNING</b>	<ul style="list-style-type: none"> <li>• Please observe the installation instructions specified in this manual, including the installation environment and clearance requirements.</li> <li>• Install the WIT Inverter in a dry and well-ventilated location; otherwise, performance de-rate may be initiated due to excessive temperature.</li> <li>• Please read the installation instructions and safety precautions carefully before installation.</li> </ul>

### Electrical Connections:



 <b>DANGER</b>	<ul style="list-style-type: none"> <li>• Before connecting cables, ensure that the DC switches of the WIT Inverter are OFF, and turn off the switch and breaker on the AC side and the battery side. Otherwise, high voltages may cause severe injuries.</li> <li>• It must be operated by qualified and trained electrical technicians. Technicians should observe instructions in this manual and local regulations.</li> <li>• High voltages may cause electric shocks and serious injury. Please do not touch the WIT Inverter in operation.</li> <li>• Do not install the inverter in potentially explosive and flammable atmospheres.</li> </ul>
--	--

 <b>WARNING</b>	<ul style="list-style-type: none"> <li>Each WIT Inverter must be equipped with an AC circuit breaker. Multiple WIT Inverters cannot connect to the same AC circuit breaker.</li> <li>Do not connect the load between the WIT Inverter and the circuit breaker.</li> <li>If the cable is thick, do not shake the cable terminals after tightening them. Otherwise, the loose connection may cause overheating and device damage. Ensure that the terminals are properly connected before starting the WIT Inverter.</li> <li>Ensure the correct polarity of the terminals before connecting the PV array to the WIT Inverter.</li> </ul>
---	---



#### Maintenance and replacement:



 <b>DANGER</b>	<ul style="list-style-type: none"> <li>It must be operated by qualified and trained electrical technicians. Technicians should observe instructions in this manual and local regulations.</li> <li>After turning off the DC switches and the AC breakers, wait for at least five minutes before performing any operations to avoid risks.</li> <li>When the OLED screen indicates "PV Isolation low", do not touch the chassis as a ground fault may have been detected.</li> <li>Beware of high voltages which may cause electric shocks.</li> </ul>
 <b>WARNING</b>	<ul style="list-style-type: none"> <li>To ensure good dissipation, clean the fan regularly.</li> <li>Do not use the air pump to clean the fan. Otherwise, the fan may be damaged.</li> </ul>

#### Others:







 <b>i</b>	<ul style="list-style-type: none"> <li>Upon receiving the product, check if the contents are intact and complete. If any damage is found or any component is missing, please contact your distributor.</li> </ul>
 <b>WARNING</b>	<ul style="list-style-type: none"> <li>The maximum PV input voltage cannot exceed 1100V. The battery input voltage cannot exceed 1000V.</li> <li>For the WIT Inverter that will not be put into operation in the future, you should properly dispose of them by yourself.</li> </ul>

## 2.2 Symbol Conventions

Symbol	Description
 <b>DANGER</b>	<b>DANGER</b> indicates a hazard with a high level of risk which, if not avoided, will result in death or serious injury.
 <b>WARNING</b>	<b>WARNING</b> indicates a potentially hazardous situation which, if not avoided, could result in death or serious injury.

Symbol	Description
 <b>CAUTION</b>	<b>CAUTION</b> indicates a hazard with potential risk which, if not avoided, could result in minor or moderate injury.
 <b>NOTICE</b>	<b>NOTICE</b> indicates that under certain circumstances, improper operations could result in property damage.
	<b>Remind</b> operators to check the instructions before installing or operating the WIT Inverter.

## 2.3 Label Description

Symbol	Name	Meaning
	High voltage	High voltages exist after the WIT Inverter is powered on. Only qualified and trained electrical technicians are allowed to perform operations.
	Burn warning	Do not touch a running inverter because it generates high temperatures on the shell.
	Grounding	Indicates the position for connecting the PE cable.
	Delay discharge mark	Residual voltage exists after the WIT Inverter is powered off. It takes 5 minutes to discharge to the safe voltage.
	Refer to the manual	Remind operators to refer to the manual before installing and operating the WIT Inverter.
	DC	Direct Current.
	AC	Alternating Current.

# 3 Product Description



NOTICE

The front view and the bottom view of all models are identical.

## 3.1 Overview

Front view:

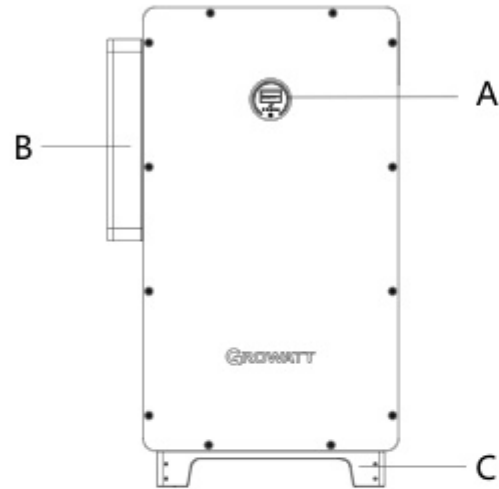

Fig 3.1 Front view

Bottom view:

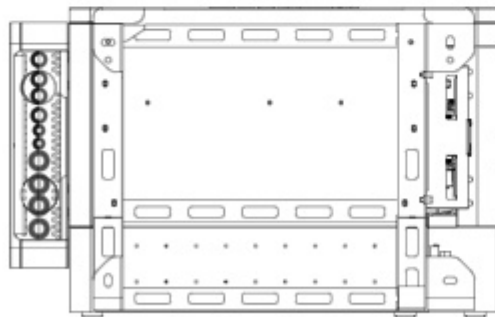

Fig 3.2 Bottom view

Left view:

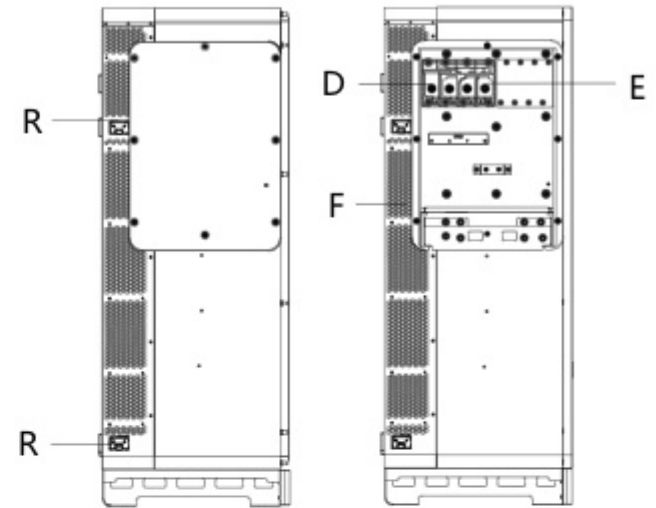

Fig 3.3 Left view of WIT 50-100K-A and WIT 50-100K-H

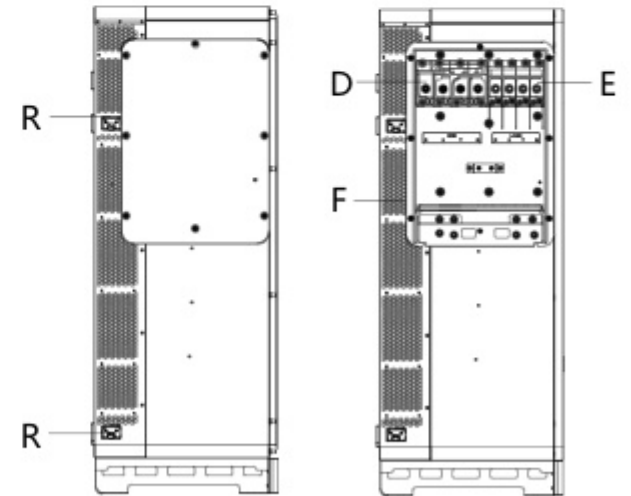

Fig 3.4 Left view of WIT 50-100K-AE, WIT 50-100K-AU, WIT 50-100K-HE and WIT 50-100K-HU

Right view:

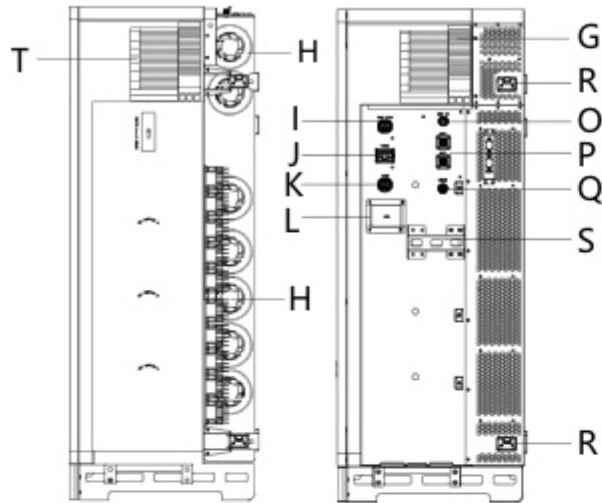

Fig 3.5 Right view of WIT 50-100K-A, WIT 50-100K-AE and WIT 50-100K-AU

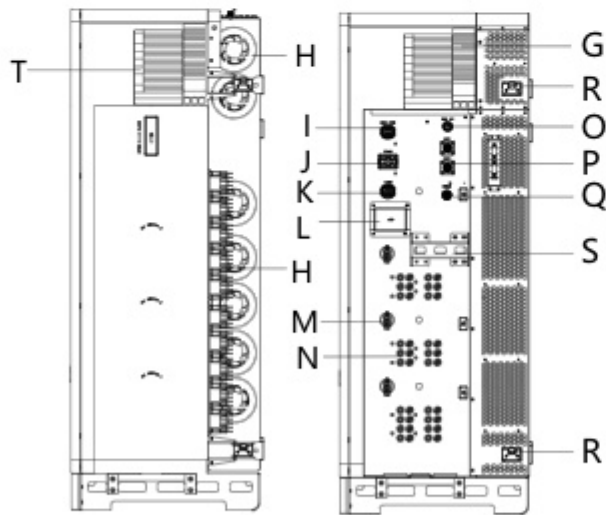

Fig 3.6 Right view of WIT 50-100K-H, WIT 50-100K-HE, WIT 50-100K-HU

Table 3.1 Component description

No.	Description	No.	Description
A	Display	B	AC junction box
C	Base	D	Power grid connection terminal
E	Load wiring terminal	F	Heat sink
G	Nameplate	H	Fan
I	16-pin terminal (BMS COM)	J	30 pin terminal (COM2)
K	16-pin terminal (COM1)	L	USB interface box
M	DC Switch	N	PV terminal
O	Battery supply terminal (BMS AC)	P	Battery terminal
Q	DRMS port	R	Flexible handle (4 groups)
S	Fixed handle	T	Indicator description label

### 3.2 Basic Data

Table 3.2 Dimensions and weight

	Model	Size (mm)			Weight (kg)
		Height	Width	Depth	
The WIT Inverter without package	WIT 50/63/75/100K-A	1350	820	510	120/120/120/120
	WIT 50/63/75/100K-H				133/133/140/140
	WIT 50/63/75/100K-AE				130/130/130/130
	WIT 50/63/75/100K-HE				143/143/150/150
	WIT 50/63/75/100K-AU				140/140/140/140
	WIT 50/63/75/100K-HU				153/153/160/160
The WIT Inverter with package	WIT 50/63/75/100K-A	1524	988	733	160/160/160/160
	WIT 50/63/75/100K-H				173/173/180/180
	WIT 50/63/75/100K-AE				170/170/170/170
	WIT 50/63/75/100K-HE				183/183/190/190
	WIT 50/63/75/100K-AU				180/180/180/180
	WIT 50/63/75/100K-HU				193/193/200/200

### 3.3 Nameplate

The following figure shows the nameplate of WIT 100K-HU and WIT 100K-AU as examples. The nameplate figure is for reference only. The actual nameplate prevails. For detailed specifications, please refer to Section 10 Product Specifications.

GROWATT Hybrid Inverter	
Model name	WIT 100K-HU
PV input data	
Max. PV voltage	1100 d.c.V
MPPT voltage range	180-800 d.c.V
PV Isc	40 d.c.A*10
Max. input current	32 d.c.A*10
AC input/output data	
Nominal input/output power	200 KW/100 kW
Max. input/output apparent power	200 kVA/110 kVA
Nominal voltage	3W/N/PE 230/400 a.c.V
Max. input/output current	303/166.7 a.c.A
Nominal frequency	50/60 Hz
Power factor range	1 leading~1 lagging
Backup power	
Nominal AC output power	100 kW
Nominal AC output voltage	230/400 a.c.V
Nominal AC output frequency	50/60 Hz
Battery data	
Battery voltage range	600-1000 d.c.V
Max. charging and discharging current	167 d.c.A
Type of battery	Lithium-ion
Others	
Safety level	Class I
Ingress protection	IP66
Operation ambient temperature	-30°C - +60°C
Made in China	

GROWATT Storage Inverter	
Model name	WIT 100K-AU
AC input/output data	
Nominal input/output power	200 kW/100 kW
Max. input/output apparent power	200 kVA/110 kVA
Nominal voltage	3W/N/PE 230/400 a.c.V
Max. input/output current	303/166.7 a.c.A
Nominal frequency	50/60 Hz
Power factor range	1 leading~1 lagging
Backup power	
Nominal AC output power	100 kW
Nominal AC output voltage	230/400 a.c.V
Nominal AC output frequency	50/60 Hz
Battery data	
Battery voltage range	600-1000 d.c.V
Max. charging and discharging current	167 d.c.A
Type of battery	Lithium-ion
Others	
Safety level	Class I
Ingress protection	IP66
Operation ambient temperature	-30°C - +60°C
Made in China	

Fig 3.7 Nameplate

### 3.4 Operating Principle

#### 3.4.1 Operating Principle of WIT 50-100K-A

- 1> Convert DC power into AC power consistent with the voltage and power quality requirements of the utility grid through an inverter circuit to supply power to the loads and feed power into the grid;
- 2> Convert AC power into DC power through a rectifying circuit to charge the battery

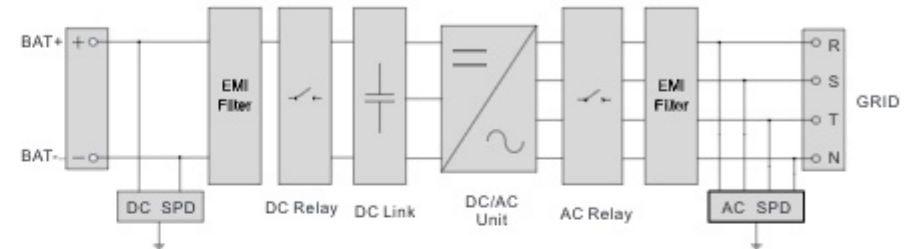

Fig 3.8 WIT 50-100K-A Grid-connected conceptual diagram

#### 3.4.2 Operating Principle of WIT 50-100K-H

- 1> The Hybrid Inverter receives DC inputs from PV strings which go through the MPPT routes. The DC power is then converted into AC power through an inverter circuit to power the loads and feed power into the grid;
- 2> The PV strings can supply power to charge the battery through the MPPT routes;
- 3> Convert battery power to AC power supplies for the loads and feeding to the grid;
- 4> Charge the battery from the grid through a rectifier circuit.

**NOTE:** WIT 50K-H models have 7 MPPT routes. WIT 63K-H models have 8 MPPT routes. WIT 75K-H and WIT 100K-H models have 10 MPPT routes.

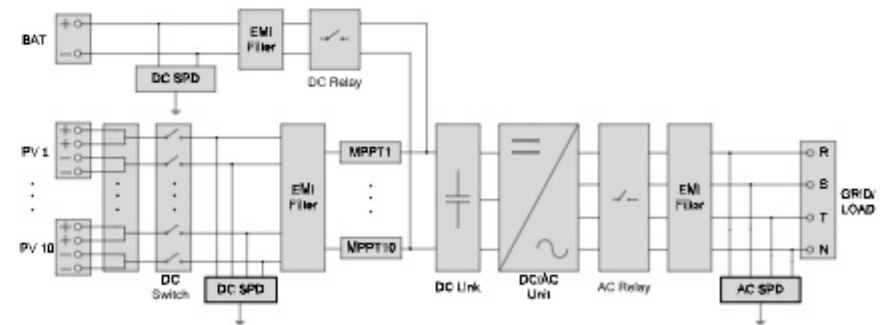

Fig 3.9 WIT 50-100K-H Grid-connected conceptual diagram



### 3.4.3 Operating Principle of WIT 50-100K-AE and WIT 50-100K-AU

- 1> Convert battery power to AC power supply for the loads or feeding the energy to the grid;
- 2> Charge the battery from the grid through a rectifier circuit;
- 3> Convert the battery power into AC power through the inverter circuit to provide power to critical loads.

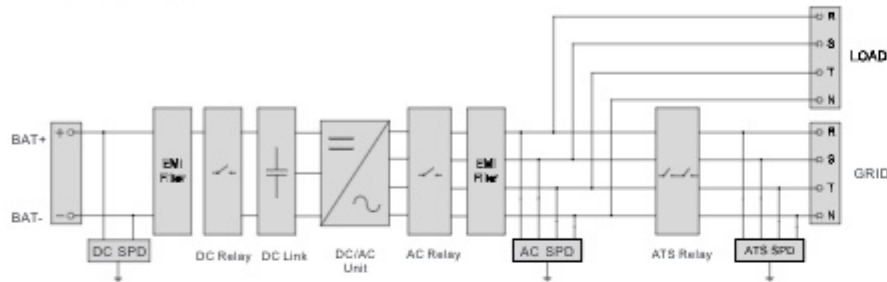

Fig 3.10 WIT 50-100K-AE and WIT 50-100K-AU Grid-connected conceptual diagram

### 3.4.4 Operating Principle of WIT 50-100K-HE and WIT 50-100K-HU

- 1> The Hybrid Inverter receives DC inputs from PV strings which go through the MPPT routes. The DC power is then converted into AC power through the inverter circuit to power the loads and feed power into the grid;
- 2> The PV strings can supply power to charge the battery through the MPPT routes;
- 3> Convert battery power to AC power for the loads and feeding to the grid;
- 4> Charge the battery from the grid through a rectifier circuit;
- 5> Convert DC input from PV strings and the battery power into AC power through the inverter circuit to power critical loads.

**NOTE:** WIT 50K-HE/-HU models have 7 MPPT routes. WIT 63K-HE/-HU models have 8 MPPT routes. WIT 75K-HE/-HU and WIT 100K-HE/-HU models have 10 MPPT routes.

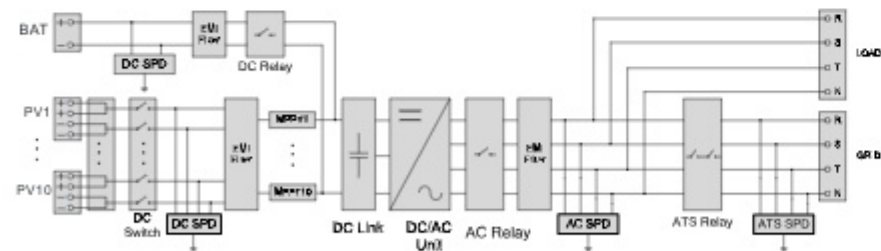

Fig 3.11 WIT 50-100K-HE and WIT 50-100K-HU Grid-connected conceptual diagram

### 3.5 Storing the WIT Inverter

- 1> Put the WIT Inverter in the original package and place it in a dry and well-ventilated place.
- 2> Keep the storage temperature from  $-30^{\circ}\text{C}$  to  $+70^{\circ}\text{C}$  and the humidity from 0%–95% RH.
- 3> A maximum of three WIT Inverters can be stacked. Do not stack inverters without package.
- 4> If the WIT Inverter has been long-term stored, inspections and tests should be conducted by qualified personnel before installation.



Wrong time and date may occur if the WIT Inverter has been stored for over one month. Fix the time and date before connecting the WIT Inverter to the grid. For details, see 7.2 Commissioning the WIT Inverter.

### 3.6 Supported Grid Types

Grid connection modes for WIT 50-100K Storage/Hybrid Inverters are shown in Figure 3.12.

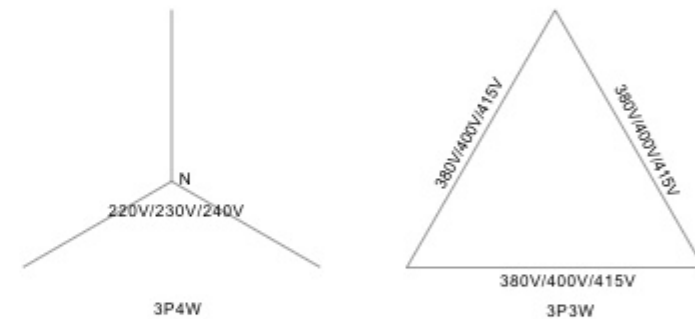

Fig3.12 380V /400V system(type Y/Δ)

### 3.7 AFCI Function

#### 3.7.1 AFCI function description

An AFCI, or Arc-Fault Circuit Interrupter, is a solution designed to detect and mitigate the risk of electrical arcing in a photovoltaic (PV) system, supported by intelligent arc detection algorithm. Arcing can occur when there is a high voltage breakdown in the electrical insulation or when conductive materials come into contact with each other. This can pose a fire hazard and damage the system components. The AFCI continuously monitors the system for potential arc faults and, if detected, interrupts the circuit to prevent a fire or other damage. AFCIs are required by the National Electrical Code (NEC) in certain parts of a PV system, such as the DC side of the inverter, to improve safety and reduce the risk of fires.

#### NOTE:

1. The AFCI Function of the WIT Inverter is disabled by default. If you want to enable the AFCI, please contact Growatt support.
2. Do not connect the Maximum Power Point Trackers (MPPTs) on the DC side in parallel as it might trigger the AFCI mistakenly.

# Inspection upon delivery 4

## 3.7.2 Clearing the alarm

In the event that the WIT Inverter reports "Error 200" and the PV indicator turns red, an arc fault might have been detected. Please perform the following steps to clear the alarm.

**Step 1:** Disconnect the WIT inverter from all power sources. Turn off the battery switch and the AC output circuit breaker, then turn the DC switches to the OFF position. Wait until the error message disappears.



Fig 3.13

**Step 2:** Troubleshooting. Check if the open-circuit of all PV strings are within the permissible range.

**Step 3:** After the fault is rectified, restart the inverter. Turn on the battery switch and the AC breaker, and turn the DC switch to the ON position. Wait until the system is working properly.



Fig 3.14

If the WIT Inverter passes the AFCI self-test, it will work in the normal mode and the PV indicator will be green. If it fails, the inverter will report "Error 425". In this case, please reboot the system and perform Step 1 to Step 3. If it failed again, please disconnect all power sources and contact Growatt support.

## 3.8 Anti-PID Function

PID refers to the potential induced degradation. It occurs when a large amount of charge accumulates on the surface of the PV modules, causing the surface passivation to deteriorate. This leads to a decrease in the fill factor, open-circuit voltage, short-circuit current, and the power output of the PV modules. The Anti-PID function enables the WIT Inverters to mitigate the PID effect by rectifying and boosting the AC voltage or battery voltage during nighttime to generate a DC voltage. The DC voltage is connected to the PV positive terminal and the ground, applying a positive bias to reverse the PID effect and extend the service life of the PV modules.

**NOTE:** The Anti-PID function is optional.

## Unpacking and inspection

1> Before unpacking the WIT Inverter, check the shipping box for any externally visible damage. If any damage is found, contact the shipping company as soon as possible.  
2> After unpacking the WIT Inverter, check if the scope of delivery is intact and complete. If any damage is found or any component is missing, contact your distributor.  
Check the following items:

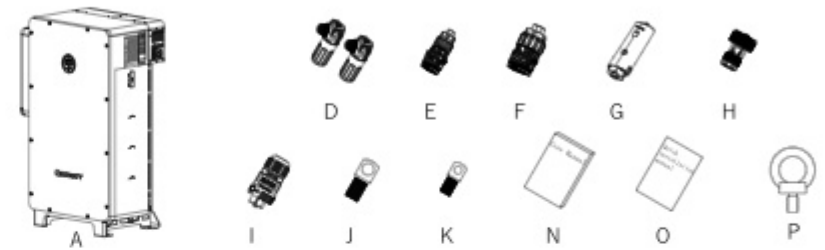

Fig 4.1 WIT 50-100K-A Scope of Delivery

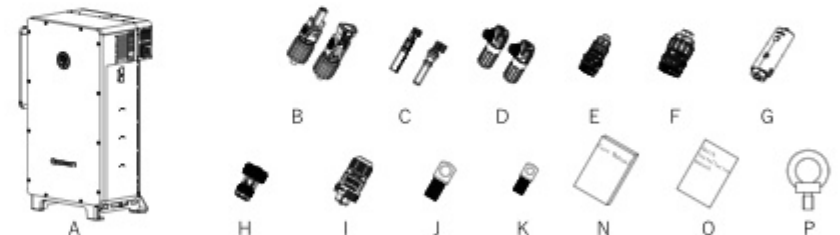

Fig 4.2 WIT 50-100K-H Scope of Delivery



Fig 4.3 WIT 50-100K-AE, WIT 50-100K-AU Scope of Delivery

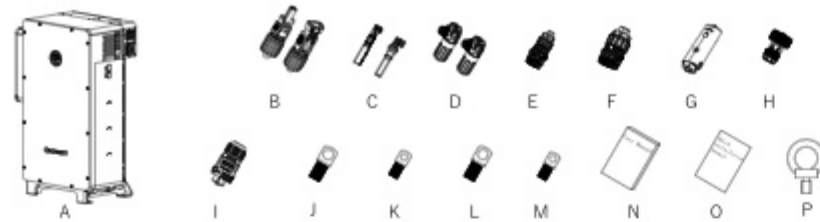

Fig 4.4 WIT 50-100K-HE, WIT 50-100K-HU Scope of Delivery

Table 4.1 Packing list

No.	Description	Quantity
A	WIT Storage/Hybrid Inverter	1
B	PV+ connector, PV - connector	20/20
C	PV+ metal contact, PV- metal contact	20/20
D	Battery + terminal, Battery - terminal	1/1
E	16-pin terminal	2
F	30-pin terminal	1
G	Data logger	1
H	RJ45 connector protector	1
I	BMS power supply terminal	1
J	SC70-12	4
K	SC50-8	1
L	SC120-12	4
M	SC70-8	1
N	User manual	1
O	Quick Installation guide	1
P	Hoist ring	2

**NOTE:**

1. The table above shows the packing list of the WIT 100K-HU Hybrid inverter as an example. For WIT 50-100K-H, WIT 50-100K-HE, WIT 50-100K-HU models, 14 pairs of PV connectors and 14 pairs of metal contacts are delivered with 50kW models; 16 pairs of PV connectors and 16 pairs of metal contacts are delivered with 63kW models; 20 pairs of PV connectors and 20 pairs of metal contacts are delivered with 75kW and 100kW models.
2. Sturdy and durable though the packing carton is, please carry and handle it with caution.

## 5.1 Basic Installation Requirements

- A. Ensure that the installation surface is solid enough to bear the weight of the WIT Inverter. (Refer to Table 3.2 for the weight of the WIT Inverter)
- B. Ensure that the installation position is suitable for the dimensions of the WIT Inverter.
- C. Do not install the WIT Inverter in areas with flammable or thermolabile materials.
- D. The WIT Inverter is protected to IP66 and can be installed indoors or outdoors.
- E. Do not expose the WIT Inverter to direct sunlight. Otherwise, excessive temperature may lead to power reduction.
- F. Keep the humidity at 0% to 95% RH.
- G. Keep the ambient temperature at -30°C to 60°C.
- H. The WIT inverter can only be vertically mounted on a flat ground or a vertical wall. Please refer to the following figures:

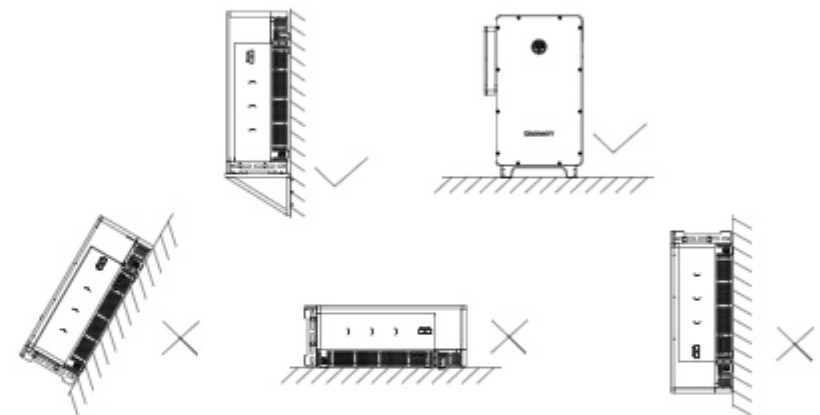

Fig 5.1

- I. Reserve enough clearance around the WIT Inverter to ensure sufficient space for heat dissipation and operation. Ensure that there are no objects within 1 m of the left, right and top of the WIT Inverter; In ground-mounted installation, keep the back of the chassis at least 0.1m away from the wall surface to ensure the optimal performance of the WIT Inverter.

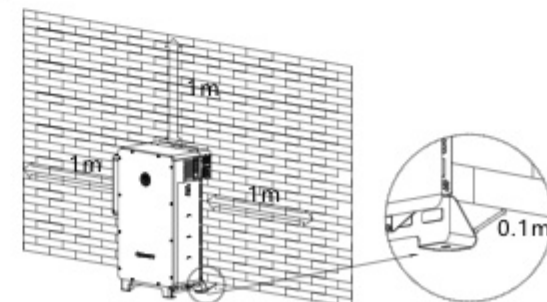

Fig 5.2

- J. Keep the WIT Inverter away from strong interference sources.
- K. Ensure that the WIT Inverter is not accessible to children.

## 5.2 Installation Environment Requirements

- A. Though the WIT Inverter is protected to IP66, do not expose it to direct sunlight, rain and snow. Please refer to the figures below:

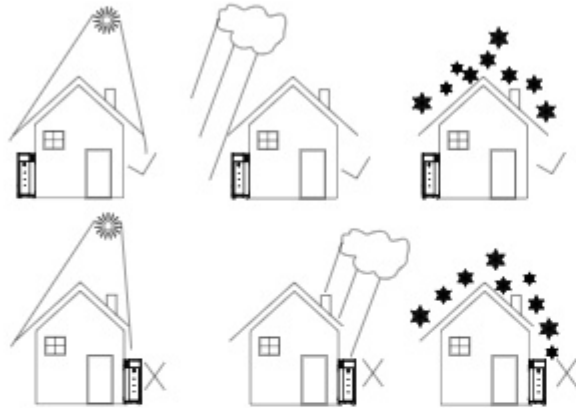

Fig 5.3

- B. It is recommended an awning be installed over the WIT Inverter to extend its service life and avoid performance de-rate. Ensure that a distance of at least 1 m exists between the frame of the awning and the top of the WIT Inverter and 1.5 m between the sides of the awning and the WIT Inverter. Please refer to the figures below.

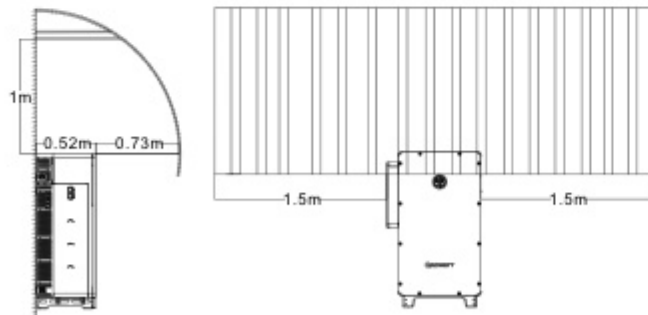

Fig 5.4

- C. Do not operate the WIT Inverter in an enclosed or narrow space.

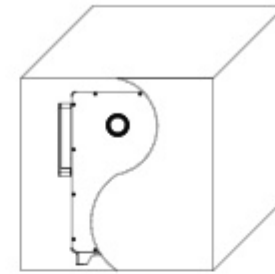

Fig 5.5

## 5.3 Moving the WIT Inverter



CAUTION

- To prevent personal injury caused by a falling inverter, keep balance and be careful when moving the WIT Inverter as it is heavy.

### Plan 1 Hoisting:

- 1> As shown in Fig 5.6 below, unpack the WIT Inverter (remove the top panel and the support plates). Then piece the support plates together with the bottom panel. Install the hoisting rings and pull out the handles. Turn the WIT Inverter upright using the handles. Run a rope strong enough to bear the inverter through the hoisting rings and hoist the equipment, and then move the inverter to the installation position;
- 2> Keep balance when hoisting and moving the WIT Inverter.

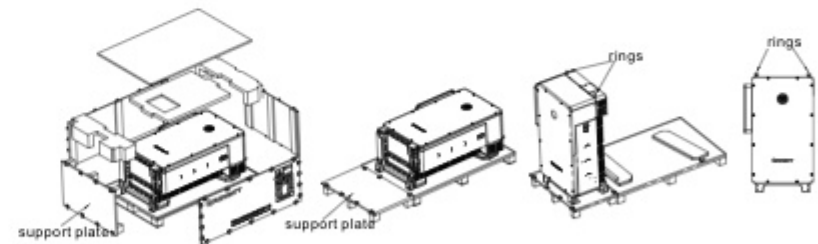

Fig 5.6 Hoisting the WIT Inverter

### Plan 2 Forklift handling:

- 1> Unpack the WIT Inverter (remove the top panel and the support plates); turn the equipment upright (place it on a flat ground or a floor support);
- 2> As shown in Fig 5.7, operate the forklift to insert the tines into the pallet openings to lift the inverter and then transport it to the installation position. (the fork width should be less than 0.42 m);
- 3> Keep balance when lifting and moving the WIT Inverter.

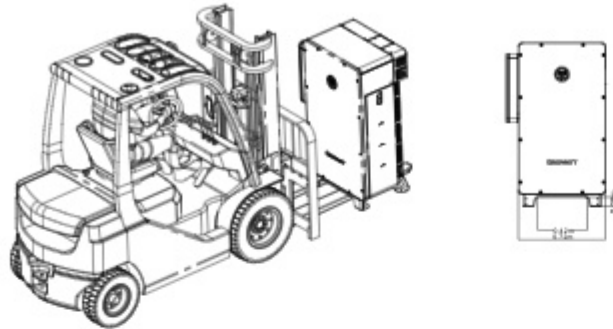

Fig 5.7 Moving the WIT Inverter with a forklift

**Plan 3 Lifting:**

- 1> Unpack the WIT Inverter (remove the top panel and the support plates) and pull out the handles, as shown in Fig 5.8 below. It requires four people to lift the WIT Inverter and move it to the installation position;
- 2> Keep balance when lifting and moving the WIT Inverter.

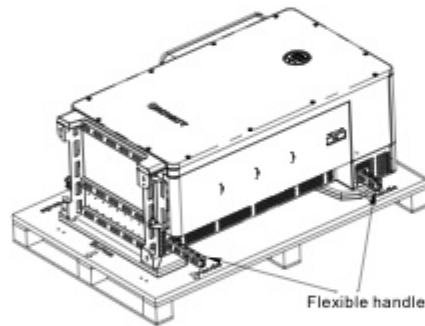

Fig 5.8 Lifting the WIT inverter

**5.4 Mounting the WIT Inverter**

**5.4.1 Ground-mounting Installation**

The WIT 50-100K Storage/Hybrid Inverters can be installed on the ground. Determine the hole positions using the marking-off template and drill holes into the ground. Insert nuts ( $\varphi 12$ ) into the ground, and then place the inverter in the correct position and tighten the screws. The dimensions of the marking-off template are shown in Fig 5.9.

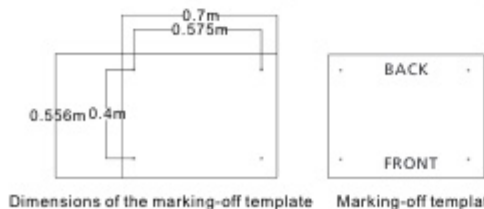

Fig 5.9 Floor-mounting installation hole positions

Refer to figure 5.10 for floor-mounting installation.

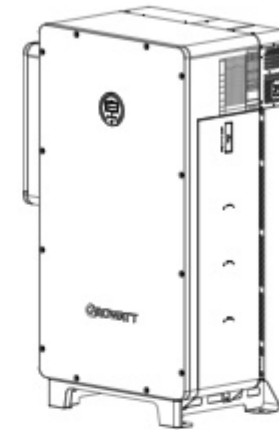

Fig 5.10 Floor-mounting installation

**5.4.2 Wall-mounting Installation**

The WIT 50-100K Storage/Hybrid Inverters can be mounted on the wall. For wall-mounted installation, you need to purchase the mounting bracket from Growatt. Determine the hole positions for installing the mounting bracket using the marking-off template and drill holes. Align the mounting bracket with the hole positions and insert nuts ( $\varphi 12$ ) into the holes. Secure the mounting bracket by tightening the screws. Then install the WIT Inverter on the bracket and secure it to the wall. Please refer to Fig 5.11 for the dimensions of the marking-off template and Fig 5.12 for the wall-mounted installation diagram.

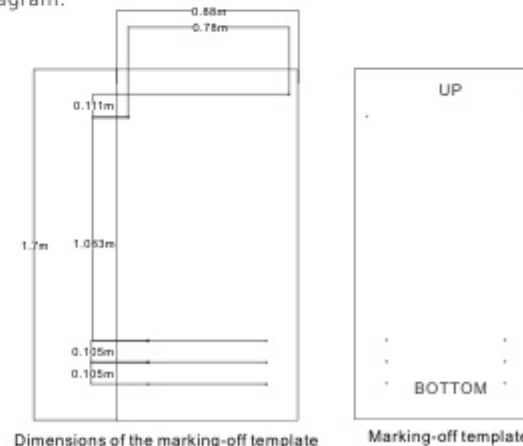

Fig 5.11 Marking-off template for wall-mounting installation

**NOTE:** The marking-off template and mounting bracket are optional accessories. Customers who purchase the mounting bracket will have a marking-off template delivered with the bracket.

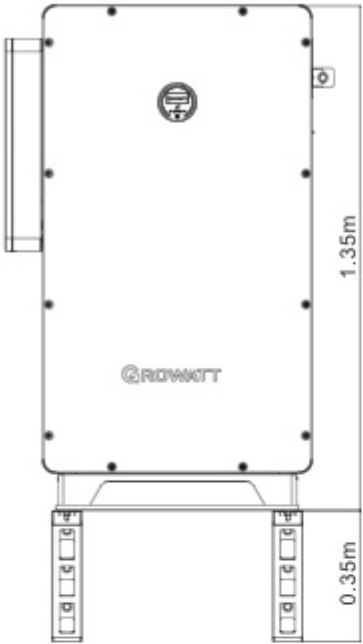

Fig 5.12 Wall-mounting installation



NOTICE

Ensure that the wall meets the load-bearing requirements of the equipment. For details about the weight of the inverter, see Table 3.2.

## Electrical Connection 6

A maximum of 7 PV strings can be connected to the WIT 50K Hybrid Inverter, 8 strings to the 63K model and 10 strings to the 75K and 100K models.

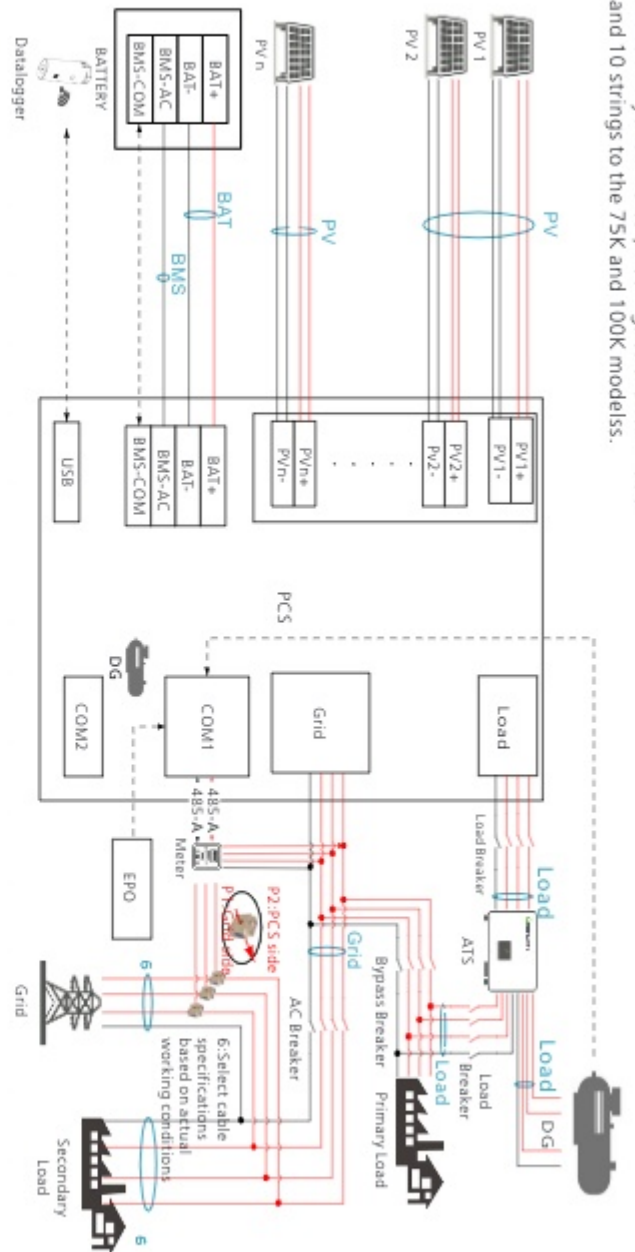

PV	BAT	BMS	Load	Grid	Load Breaker	AC Breaker	Bypass Breaker	PV	BAT	BMS	Load	Grid	Load Breaker	AC Breaker	Bypass Breaker						
50K	4-6 mm <sup>2</sup>	50 mm <sup>2</sup>	1.5 mm <sup>2</sup>	35 mm <sup>2</sup>	95 mm <sup>2</sup>	150A	150A	300A	300A	150A	150A	75K	4-6 mm <sup>2</sup>	50 mm <sup>2</sup>	1.5 mm <sup>2</sup>	70 mm <sup>2</sup>	150 mm <sup>2</sup>	250A	250A	400A	250A
63K	4-6 mm <sup>2</sup>	50 mm <sup>2</sup>	1.5 mm <sup>2</sup>	35 mm <sup>2</sup>	95 mm <sup>2</sup>	150A	150A	300A	300A	150A	150A	100K	4-6 mm <sup>2</sup>	50 mm <sup>2</sup>	1.5 mm <sup>2</sup>	70 mm <sup>2</sup>	150 mm <sup>2</sup>	250A	250A	400A	250A

Wiring diagram of the system with a single WIT 50-100K-HU inverter

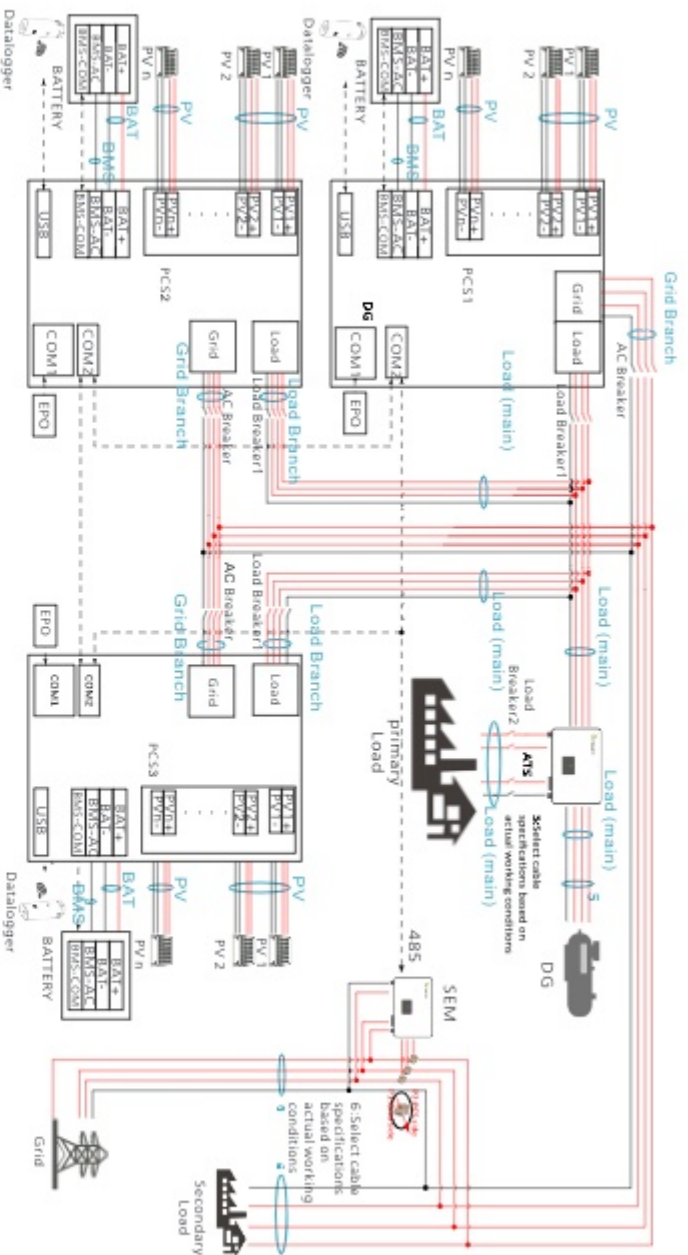

Wiring diagram of the system with three WIT 50-100K-HU inverters connected in parallel

PV	BAT	BMS	Load Branch	Grid Branch (main)	Breaker	AC Branch	Bypass Breaker	PV	BAT	BMS	Load Branch	Grid Branch (main)	Breaker	AC Branch	Bypass Breaker
4-6	50	1.5	35	95	95	150A	400A	4-6	50	1.5	70	150	150	250A	600A
50K	mm <sup>2</sup>	mm <sup>2</sup>	mm <sup>2</sup>	mm <sup>2</sup>	mm <sup>2</sup>	mm <sup>2</sup>	mm <sup>2</sup>	mm <sup>2</sup>	mm <sup>2</sup>	mm <sup>2</sup>	mm <sup>2</sup>	mm <sup>2</sup>	mm <sup>2</sup>	mm <sup>2</sup>	mm <sup>2</sup>
4-6	50	1.5	35	95	95	150A	400A	4-6	50	1.5	70	150	150	250A	600A
63K	mm <sup>2</sup>	mm <sup>2</sup>	mm <sup>2</sup>	mm <sup>2</sup>	mm <sup>2</sup>	mm <sup>2</sup>	mm <sup>2</sup>	mm <sup>2</sup>	mm <sup>2</sup>	mm <sup>2</sup>	mm <sup>2</sup>	mm <sup>2</sup>	mm <sup>2</sup>	mm <sup>2</sup>	mm <sup>2</sup>

A maximum of 7 PV strings can be connected to the WIT 50K Hybrid Inverter; 8 strings to the 75K and 100K models.

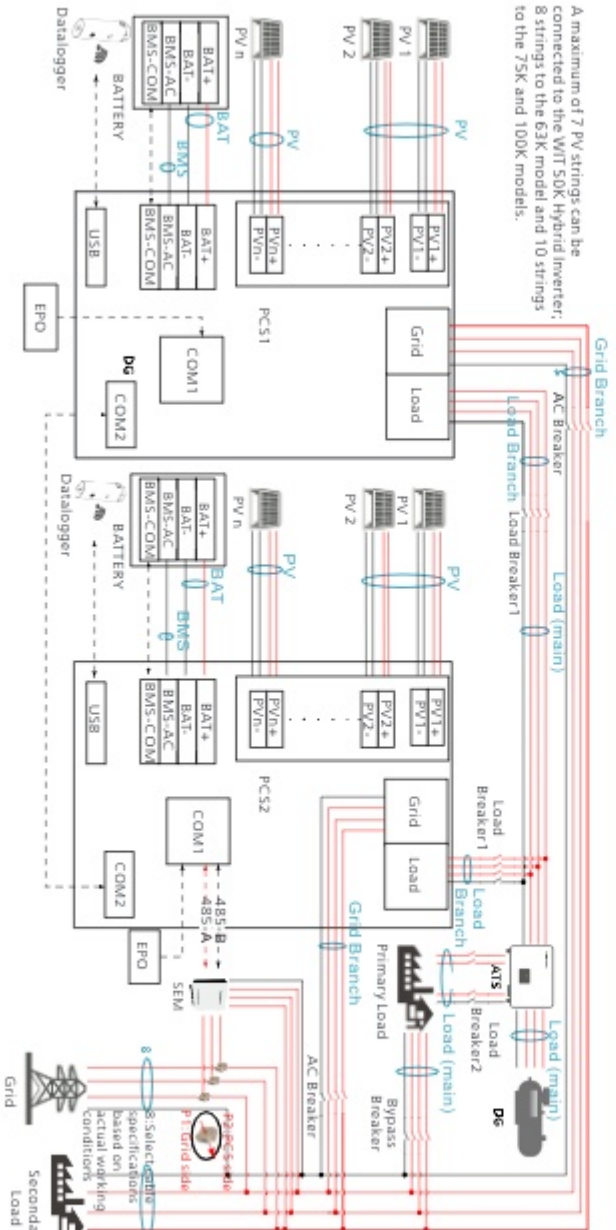

Wiring diagram of the system with two WIT 50-100K-HU inverters connected in parallel

PV	BAT	BMS	Load Branch	Grid Branch (main)	Breaker	AC Branch	Bypass Breaker	PV	BAT	BMS	Load Branch	Grid Branch (main)	Breaker	AC Branch	Bypass Breaker
4-6	50	1.5	35	95	95	150A	300A	4-6	50	1.5	70	150	150	250A	400A
50K	mm <sup>2</sup>	mm <sup>2</sup>	mm <sup>2</sup>	mm <sup>2</sup>	mm <sup>2</sup>	mm <sup>2</sup>	mm <sup>2</sup>	mm <sup>2</sup>	mm <sup>2</sup>	mm <sup>2</sup>	mm <sup>2</sup>	mm <sup>2</sup>	mm <sup>2</sup>	mm <sup>2</sup>	mm <sup>2</sup>
4-6	50	1.5	35	95	95	150A	300A	4-6	50	1.5	70	150	150	250A	400A
63K	mm <sup>2</sup>	mm <sup>2</sup>	mm <sup>2</sup>	mm <sup>2</sup>	mm <sup>2</sup>	mm <sup>2</sup>	mm <sup>2</sup>	mm <sup>2</sup>	mm <sup>2</sup>	mm <sup>2</sup>	mm <sup>2</sup>	mm <sup>2</sup>	mm <sup>2</sup>	mm <sup>2</sup>	mm <sup>2</sup>

Wiring diagram of the system with two WIT 50-100K-HU inverters connected in parallel

63K	PV	BAT	BMS	Load	Grid	Load Breaker	AC Breaker	Bypass Breaker	PV	BAT	BMS	Load	Grid	Load Breaker	AC Breaker	Bypass Breaker
50K	4-6 mm <sup>2</sup>	50 mm <sup>2</sup>	1.5 mm <sup>2</sup>	35 mm <sup>2</sup>	95 mm <sup>2</sup>	150A	300A	150A	4-6 mm <sup>2</sup>	50 mm <sup>2</sup>	1.5 mm <sup>2</sup>	70 mm <sup>2</sup>	150 mm <sup>2</sup>	250A	400A	250A
43K	4-6 mm <sup>2</sup>	50 mm <sup>2</sup>	1.5 mm <sup>2</sup>	35 mm <sup>2</sup>	95 mm <sup>2</sup>	150A	300A	150A	4-6 mm <sup>2</sup>	50 mm <sup>2</sup>	1.5 mm <sup>2</sup>	70 mm <sup>2</sup>	150 mm <sup>2</sup>	250A	400A	250A

A maximum of 7 PV strings can be connected to the WIT 50K Hybrid Inverter; 8 strings to the 63K model and 10 strings to the 75K and 100K models.

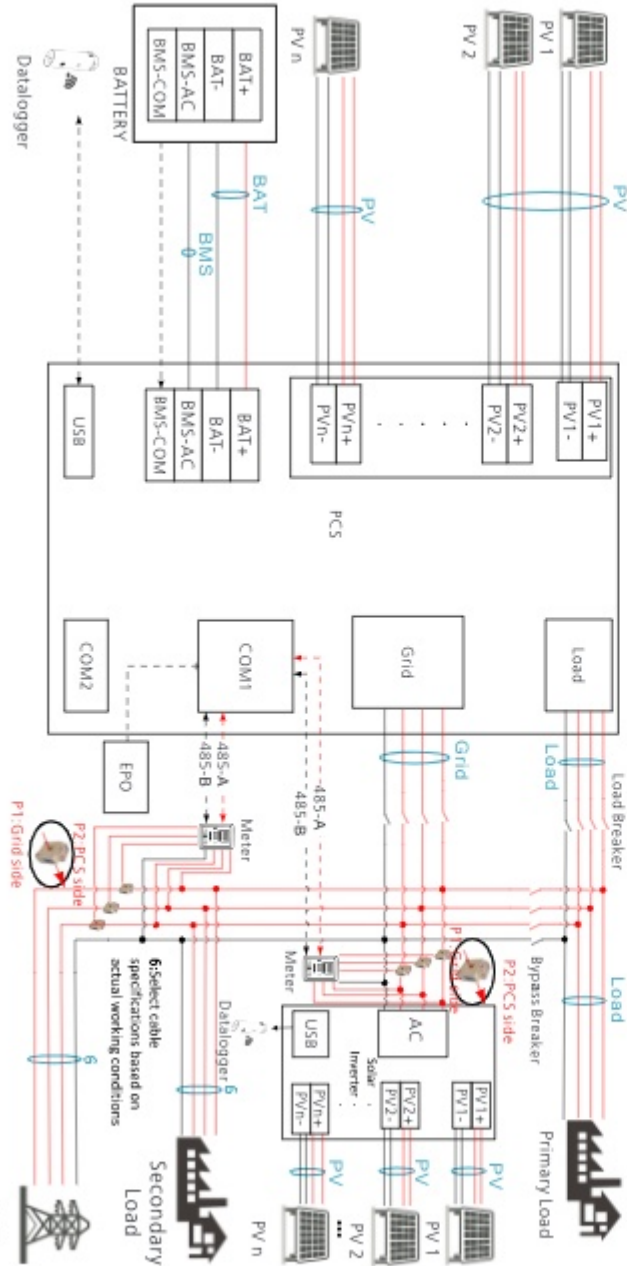

Wiring diagram of the system with a single WIT 50-100K-HU inverter and two meters

## 6.1 Connecting The Ground Cables

1. It is essential to connect the ground cable to the WIT inverter before connecting other cables to prevent personal injury or device damage.
2. All non-current-carrying metal parts and the enclosures of the devices of the energy storage system should be properly grounded, including the rack and the enclosures of the combiner box, the distribution panel, the inverter and the battery.
3. For a single WIT inverter, connect a ground cable to the ground point on the chassis shell. For a system with multiple WIT inverters connected in parallel, ensure that the enclosures of the WIT inverters, the metal racks of the PV modules and the batteries are connected to the same area to achieve equipotential bonding.
4. The position of the ground points of the WIT 50-100K Storage/Hybrid Inverter is shown in Fig 6.1. You can find the ground points after removing the right cover plate.

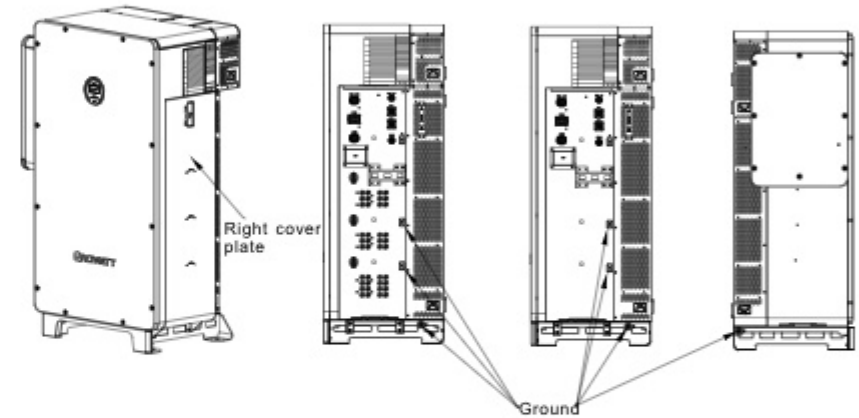



Fig 6.1 Ground points

### NOTE:

1. Keep the lightning protection grounding at the greatest possible distance from the protective grounding.
2. Protect the terminals of the ground cables against rain and do not expose them to open air.
3. Tighten the enclosure grounding screw to a torque of 60 kgf·cm.



## 6.2 Connection on the AC Side

 <b>DANGER</b>	<ul style="list-style-type: none"> <li>Before connecting cables, ensure that the DC switches on the WIT Inverter are OFF. Turn off the switches and breakers on the AC side and the battery side. Otherwise, the high voltages of the WIT Inverter may result in electric shocks.</li> <li>Only qualified and trained electrical technicians are allowed to perform operations. Technicians must observe instructions in this manual and local regulations.</li> <li>High voltages may cause electric shocks and serious injury. Please do not touch the inverter in operation.</li> <li>Do not place inflammable and explosive materials around the WIT Inverter.</li> </ul>
 <b>WARNING</b>	<ul style="list-style-type: none"> <li>Each WIT Inverter must be equipped with an AC circuit breaker. Multiple WIT Inverters cannot connect to the same AC circuit breaker (not applicable to off-grid mode).</li> <li>Please do not connect loads between the WIT Inverter and the circuit breaker.</li> <li>If the cable is thick, do not shake the cable terminals after tightening them. Otherwise, the loose connection may cause overheating that will damage the device. Ensure that the terminals are properly connected before powering on the WIT Inverter.</li> <li>After connecting the cables, apply the fireproof mud evenly on the waterproof silica gel pad inside the AC junction box to prevent water from entering into the box.</li> </ul>

### Preparation:

- 1> Ensure the grid voltage and the grid frequency are within the acceptable range;
- 2> Disconnect the DC switches and the breakers on the AC side and the battery side.

### The circuit breaker on the AC side:

A circuit breaker needs to be installed on the AC side, ensuring a safe disconnection between the WIT Inverter and the upstream input when an exception occurs.

1. Recommended circuit breaker specifications for WIT 50-100K-A and WIT 50-100K-H models.

Device type	Rated voltage of the circuit breaker	Rated current of the circuit breaker
WIT 50K-A/-H	400V	150A
WIT 63K-A/-H	400V	150A
WIT 75K-A/-H	400V	200A
WIT 100K-A/-H	400V	200A

2. Recommended circuit breaker specifications for WIT 50-100K-AE, WIT 50-100K-AU, WIT 50-100K-HE and WIT 50-100K-HU models.

Device type	Rated voltage of the circuit breaker	Rated current of the circuit breaker on the grid side	Rated current of the circuit breaker on the load side
WIT 50K-AE/-AU/-HE/-HU	400V	300A	150A
WIT 63K-AE/-AU/-HE/-HU	400V	300A	150A
WIT 75K-AE/-AU/-HE/-HU	400V	400A	250A
WIT 100K-AE/-AU/-HE/-HU	400V	400A	250A

### Recommended power cable specifications:

1. Recommended AC power cable specifications for WIT 50-100K-A and WIT 50-100K-H models.

Device type	Recommended cable specification
WIT 50K-A/-H	35mm <sup>2</sup>
WIT 63K-A/-H	35mm <sup>2</sup>
WIT 75K-A/-H	70mm <sup>2</sup>
WIT 100K-A/-H	70mm <sup>2</sup>

2. Recommended AC power cable specifications for WIT 50-100K-AE, WIT 50-100K-AU, WIT 50-100K-HE and WIT 50-100K-HU models.

Device type	Recommended cable specification on the grid side	Recommended cable specification on the load side
WIT 50K-AE/-AU/-HE/-HU	95mm <sup>2</sup>	35mm <sup>2</sup>
WIT 63K-AE/-AU/-HE/-HU	95mm <sup>2</sup>	35mm <sup>2</sup>
WIT 75K-AE/-AU/-HE/-HU	150mm <sup>2</sup>	70mm <sup>2</sup>
WIT 100K-AE/-AU/-HE/-HU	150mm <sup>2</sup>	70mm <sup>2</sup>

**NOTE:** The wires should be tinned and are not frayed or cracked.

### AC side connection steps:

1. Open the cover of the AC junction box. The position of the cover is shown in Fig 6.2;
2. Connect a ground cable to the copper grounding bar in the AC junction box. Fig 6.2 shows the position of the grounding bar inside the AC junction box;
3. Connect the main power cables according to the label. Fig 6.2 shows the position of the label and the AC terminals.

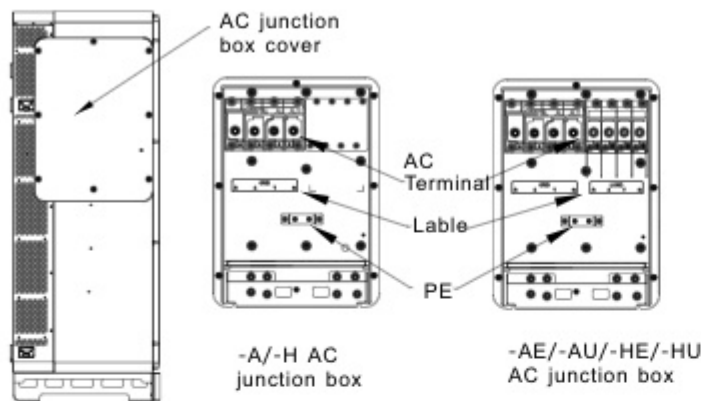

Fig 6.2 AC terminal wiring position and diagram

**NOTE:**

1. The waterproof silicone pad is used to protect the lower side of a terminal box. Cut holes in the pad according to the outer diameter of the cables to route them through. After routing through the cables, determine the cable stripped length based on the specifications of the terminals (18-22 mm is recommended). Crimp the cables and the terminals. See Figure 6.3 for crimping a cable;

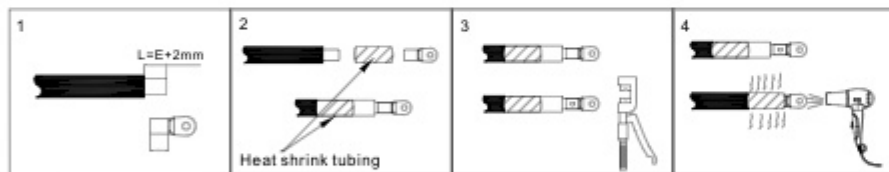

Fig 6.3 Crimping a cable

2. Cold-pressed terminals are delivered with the package. Select terminals based on the cable specifications;
3. WIT 50-100K-AE, WIT 50-100K-HE, WIT 50-100K-AU and WIT 50-100K-HU models have an additional type of terminal in the AC junction box compared with WIT 50-100KA and WIT 50-100K-H models. Connect cables according to the label ;
4. After connecting the cables, apply fireproof mud to the waterproof silicone mat at the inlet side. Lock the cover of the AC junction box after the fireproof mud is applied. See Fig 6.4 below.

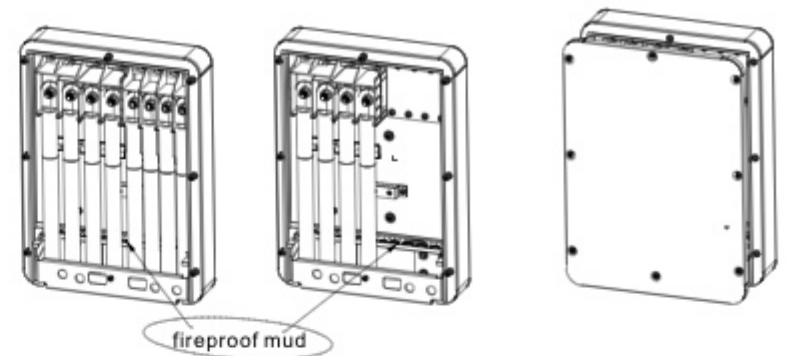

Fig 6.4 Applying fireproof mud

### 6.3 Connection on the PV Side

<p><b>NOTICE</b></p>	<ul style="list-style-type: none"> <li>• Only WIT 50-100K-H, WIT 50-100K-HE and WIT 50-100K-HU models need to be connected on the PV side.</li> </ul>
<p><b>DANGER</b></p>	<ul style="list-style-type: none"> <li>• Before connecting cables, ensure that the DC switches of the WIT Inverter are OFF, and turn off the breakers on the AC side and the battery side. Otherwise, the high voltages of the WIT Inverter may cause electric shocks.</li> <li>• Only qualified and trained electrical technicians are allowed to perform operations. Technicians must observe instructions in this manual and local regulations.</li> <li>• Check the positive and negative terminals for the correct polarity before connecting the PV module to the WIT Inverter.</li> <li>• High voltages may cause electric shocks and serious injury. Please do not touch the inverter in operation.</li> <li>• Please do not place inflammable and explosive materials around the WIT Inverter.</li> </ul>
<p><b>WARNING</b></p>	<ul style="list-style-type: none"> <li>• The maximum open-circuit voltage of each string should not exceed 1100Vdc.</li> <li>• Ensure that the following conditions are met; Otherwise, fire hazard or inverter damage may occur. Growatt is not liable for the consequence and it is beyond the warranty scope.</li> </ul>

**NOTE:**

1. The solar irradiance on the PV modules generates voltage. High voltages presented in the PV strings connected in series could be fatal. Therefore, shield the PV modules from sunlight before connecting the DC input power cable and ensure that the DC switches on the WIT Inverter are OFF.
2. The PV modules connected in series should be of the same model.
3. The maximum short-circuit current of each PV string must be lower than or equal to 40A.
4. The power of the PV panels should not exceed twice the input power of the WIT Inverter.
5. For optimal system configuration, it is recommended to connect two DC inputs with an equal number of PV modules.

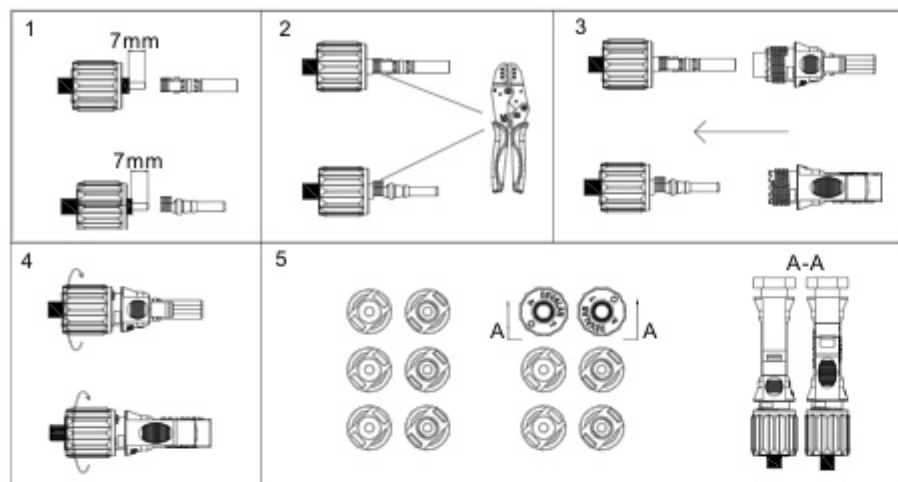

Fig 6.5 PV terminals

#### Procedure for connecting cables on the PV side:

1. Open the right cover plate of the WIT inverter, the position of which is shown in Fig 6.1;
2. Strip 6-8 mm of the insulation layer of the DC cables.
3. Insert the exposed core wires into the crimping area of the wiring terminal and crimp them using a crimping plier;
4. Route the cable through the cable sealing sleeve and insert the insulation sleeve until it snaps. Slightly pull the cable back to ensure that it is securely connected. Then tighten the locking nut;
5. Insert the positive and negative connectors of the PV modules to the corresponding terminals of the inverter. For the maximum input current of different models, please see Table 6.1. For the cable specifications, please see Table 6.2.

Table 6.1 Maximum current of a single MPPT route

Device type	Max. current of a single MPPT route
WIT 50-100K-H	16A*2
WIT 50-100K-HE	16A*2
WIT 50-100K-HU	16A*2

Table 6.2 Cable specifications on the PV side

Device type	Recommendation cable specifications
WIT 50-100K-H	4-6mm <sup>2</sup>
WIT 50-100K-HE	4-6mm <sup>2</sup>
WIT 50-100K-HU	4-6mm <sup>2</sup>

#### NOTE:

1. For a single WIT Inverter, connect the ground cable of the inverter. For a system with multiple WIT Inverters connected in parallel, connect the ground cables of all inverters and the metal racks of the PV modules to the same area to ensure equipotential bonding. Before connecting the PV cables, ensure that the ground cables on the PV side are properly connected.
2. Use male and female connectors in pair. Ensure the correct polarity before connecting the PV string to the inverter.
3. The total current of all strings cannot exceed the WIT Inverter's maximum input current;
4. Do not touch the solar panels in operation;
5. The wires should be tinned and are not frayed or cracked.

### 6.4 Connection on the Battery Side

 <b>DANGER</b>	<ul style="list-style-type: none"> <li>• Before connecting cables, ensure that the DC switches of the WIT Inverter are OFF, and turn off the breakers on the AC side and the battery side. Otherwise, the high voltages of the WIT Inverter may cause electric shocks.</li> <li>• Only qualified and trained electrical technicians are allowed to perform operations. Technicians must observe instructions in this manual and local regulations.</li> <li>• High voltages may cause electric shocks and serious injury. Please do not touch the inverter in operation.</li> <li>• Please do not place inflammable and explosive materials around the WIT Inverter.</li> </ul>
 <b>WARNING</b>	<ul style="list-style-type: none"> <li>• If the cable is thick, do not shake the cable after fastening it. Ensure that all cables are securely connected before powering on the WIT Inverter. Loose connection may cause overheating that will damage the device.</li> </ul>

#### Note:

1. The recommended battery voltage range is 600V to 1000V.
2. You are advised to install a DC circuit breaker between the battery and the WIT inverter.

#### 6.4.1 Connecting the Main Power Cable of the Battery

##### Preparation:

1. Check that the battery terminals of the WIT Inverter are intact;
2. Disconnect the DC switches on the WIT inverter, the AC breaker and the DC switch on the battery;
3. Take out the battery terminals from the accessory kit delivered with the package. See Packing list in Section 4;
4. Open the cover plate on the right side of the inverter, the position of which is shown in Fig 6.1.

**Procedure for connecting the main battery power:**

1. Connect the ground cable to the battery power ground bar, as shown in Fig 6.6;
2. Strip 18-20 mm of the insulation layer of the DC cables;
3. Crimp the battery cables and the battery terminals using crimping pliers, and then tighten the insulation sleeve;
4. Connect the battery cables to the battery terminals on the inverter, as shown in Fig 6.6;
5. After connecting the main battery power cables, bind power cables at the reserved position, as shown in Fig 6.6.

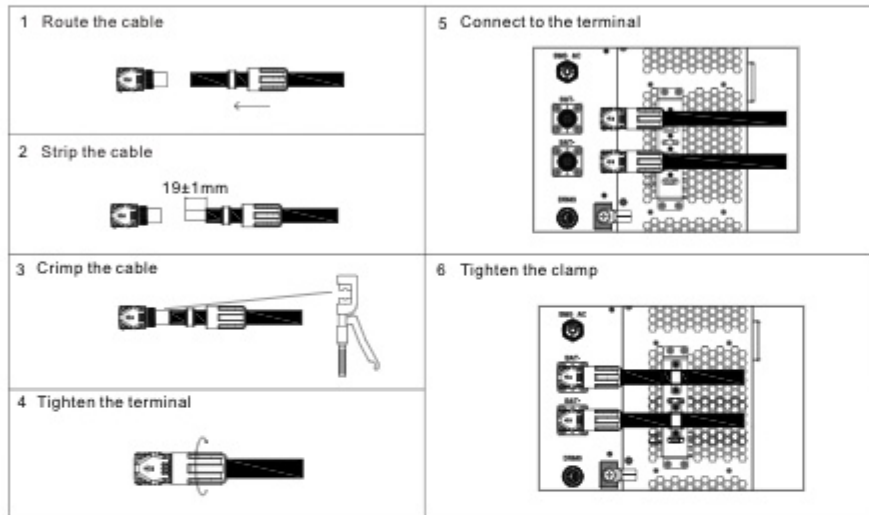

Fig 6.6 Position of the battery terminals

**NOTE:**

1. Connect the ground cable before connecting the battery cable; the ground point is shown in Fig 6.6.
2. Bind the battery power cables at the designated place after connecting them to the WIT Inverter.
3. Lock the right cover plate after connecting the cables.

**6.4.2 Connecting the Battery BMS-AC Terminal**

**NOTE:** Perform operations according to on-site requirements.

**Procedure for connecting the battery BMS-AC terminal:**

1. Open the cover plate on the right side of the inverter, the position of which is shown in Fig 6.6;
2. Find the corresponding terminal from the accessory kit. Refer to Table 6.3 to connect the terminal;
3. Remove the dustproof cover from the BMS-AC terminal, insert the terminal that has been crimped with the cables to the BMS-AC terminal, and tighten it.

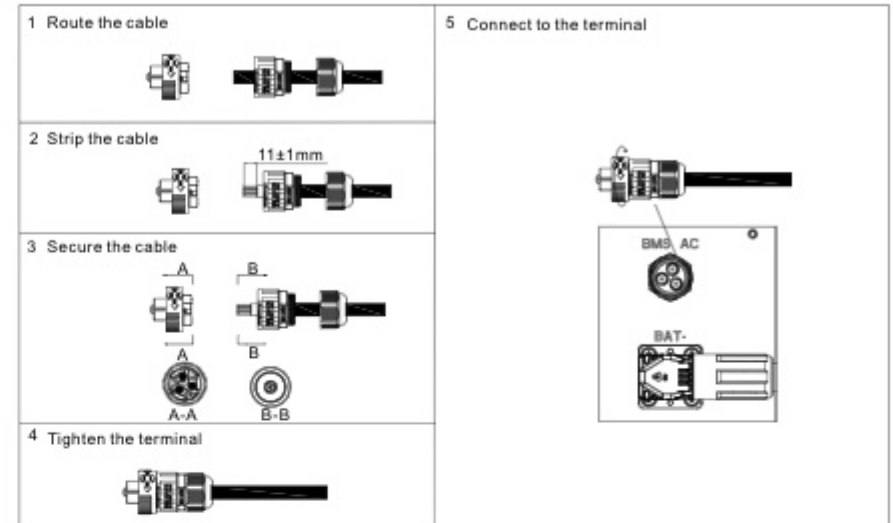

Fig 6.7 BMS-AC terminal

Table 6.3 Definitions of BMS-AC terminal

BMS-AC terminal port definition		
Number	Definition of signal	Note
1	L	Supply power to the BMS
2	N	
3	PE	Grounding

**NOTE:**

1. Do not touch or remove the dustproof cover if the BMS-AC terminal is idle.
2. Reinstall the battery protective plate and the right cover plate after the cable connection is completed.

**6.5 Connecting Communications Cables**

**6.5.1 Battery Communication Connection**

The BMS-COM terminal of the WIT 50-100K Inverter is a 16-pin connector. The matching male terminal are delivered with the package.

1. Connect the communication cables to the corresponding terminals as required. For details, see Table 6.4;
2. Remove the dustproof cover from the BMS-COM terminal, insert the 16-pin terminal (the client side) to the corresponding position, and ensure that it is tightly connected;

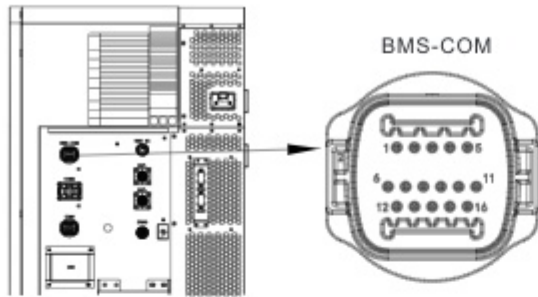

Fig 6.8 BMS-COM communication terminals

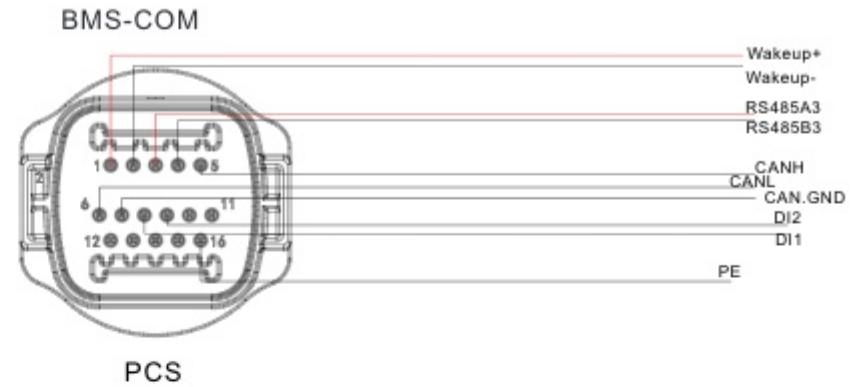

Fig 6.9 BMS-COM communication connection

Table 6.4 Battery communication terminal description

Definition of battery communication terminal		
Number	Definition of signal	Note
1	Wakeup+	Battery wake up signal
2	Wakeup-	
3	RS485A3	The PCS communicates with the battery via RS485
4	RS485B3	
5	CANH	The PCS communicates with the battery via CAN
6	CANL	
7	CAN.GND	
8	DI1	Battery shutdown input signal
9	DI2	
10	NA	NA
11	NA	
12	NA	
13	NA	
14	NA	
15	NA	
16	PE	Grounding

### 6.5.2 External Communication connection

#### NOTE:

When connecting external devices, such as the PC, please use isolated communication devices.

The external communication terminal of the WIT Inverter is a 16-pin connector. The matching terminal is in the accessory kit. The connection procedure is as follows:

1. Connect the communication cable to the corresponding terminal as required. For details, see Table 6.5;
2. Remove the dustproof cover from the COM1 terminal and insert the 16-pin terminal (the client side) to the corresponding position;

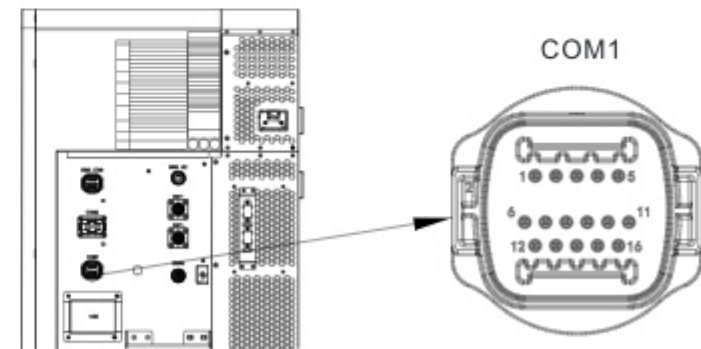

Fig 6.10 External communication terminal

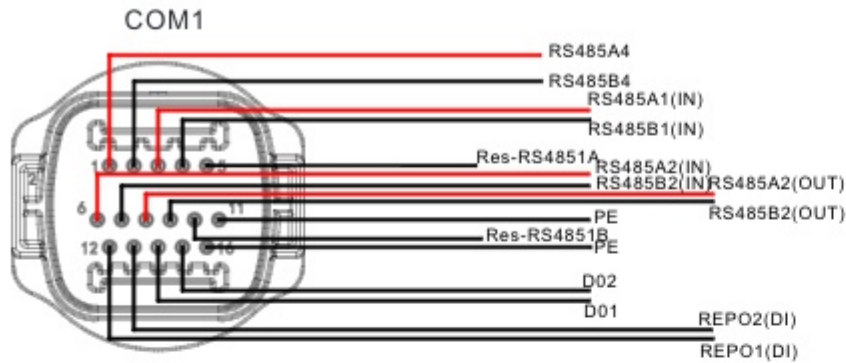

Fig 6.11 COM1 communication connection

3. The external communication terminals of the WIT 50-100K Inverters are described in Table 6.5. Short Pin 5 and pin 10 when the host computer is used.

Table 6.5 External communication terminal description

Definition of battery communication interface		
Number	Definition of signal	Note
1	PCS_RS485A_4	RS485_4
2	PCS_RS485B_4	
3	RS485A1	RS485 terminal for external communication
4	RS485B1	
5	Res_RS4851A	RS485 matching resistor
6	RS485A2	RS485 input port for the meter
7	RS485B2	
8	RS485A2	RS485 output port for the meter
9	RS485B2	
10	Res_RS4851B	RS485 matching resistor
11	PE	Grounding
12	REPO1	The WIT Inverter shutdown input dry contact signal
13	REPO2	
14	DO1	Generator start-up output dry contact signal
15	DO2	
16	PE	Grounding

### 6.5.3 Parallel Communication Connection

The parallel communication terminal (COM2) of the WIT Inverter uses a 30-pin terminal. The corresponding terminal is included in the accessory kit. Follow these steps to establish the connection:

1. Connect the communication cables to the corresponding terminals as required. For details, see Table 6.6 and Table 6.7;
2. Remove the dustproof cover from the COM2 terminal and insert the 30-pin terminal (the client side) to the corresponding position.

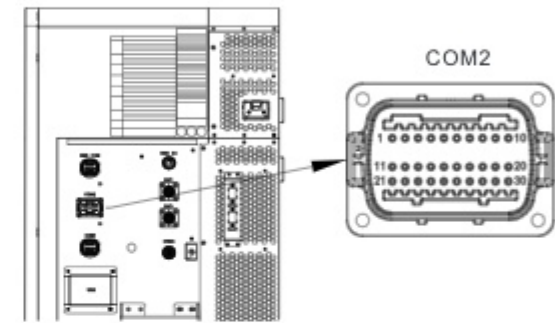
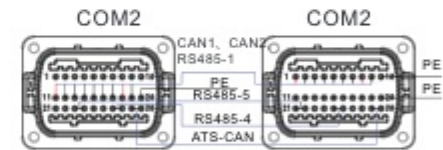
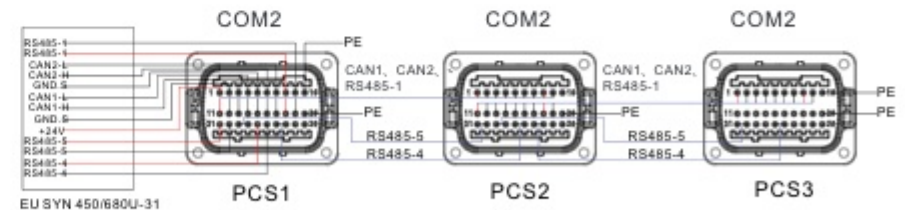

Fig 6.12 Parallel communication terminal



Parallel communication wiring diagram (dual PCS)



Parallel communication wiring diagram (three PCS)

Fig 6.13 COM2 communication connection

Table 6.6 Parallel communication terminal description

Pin definition of the parallel communication terminal (WIT 50-100K-A and WIT 50-100K-H)		
Number	Definition of signal	Note
1	24V.S	Output 24V signal
2	GND.S	
3	CAN1_H	Parallel communication CAN1 signal (input)
4	CAN1_L	
5	GND.S	
6	CAN2_H	Parallel communication CAN2 signal (input)
7	CAN2_L	
8	RS485_1A	Parallel communication 485-1 signal (input)
9	RS485_1B	
10	PE	Grounding
11	24V.S	Output 24V signal
12	GND.S	
13	CAN1_H	Parallel communication CAN1 signal (output)
14	CAN1_L	
15	GND.S	
16	CAN2_H	Parallel communication CAN2 signal (output)
17	CAN2_L	
18	RS485_1A	Parallel communication 485 signal (output)
19	RS485_1B	
20	PE	Grounding
21	RS485_5A	Low frequency synchronization 485 signal(input)
22	RS485_5B	
23	RS485_5A	Low frequency synchronization 485 signal (output)
24	RS485_5B	
25	RS485_4A	Parallel RS485_4 communication (input) (PCS)
26	RS485_4B	
27	RS485_4A	Parallel RS485_4 communication (output) (PCS)
28	RS485_4B	
29	NA	NA
30	NA	

Table 6.7 Parallel communication terminal description

Pin definition of the parallel communication terminal (WIT 50-100K-HE, WIT 50-100K-HU, WIT 50-100K-AE, WIT 50-100K-AU)		
Number	Definition of signal	Note
1	24V.S	Output 24V signal
2	GND.S	
3	CAN1_H	Parallel communication CAN1 signal (input)
4	CAN1_L	
5	GND.S	
6	CAN2_H	Parallel communication CAN2 signal (input)
7	CAN2_L	
8	RS485_1A	Parallel communication RS485 signal (input)
9	RS485_1B	
10	PE	Grounding
11	24V.S	Output 24V signal
12	GND.S	
13	CAN1_H	Parallel communication CAN1 signal (output)
14	CAN1_L	
15	GND.S	
16	CAN2_H	Parallel communication CAN2 signal (output)
17	CAN2_L	
18	RS485_1A	Parallel communication 485 signal (output)
19	RS485_1B	
20	PE	Grounding
21	RS485_5A	Low frequency sync 485 signal (input)
22	RS485_5B	
23	RS485_5A	Low frequency sync 485 signal (output)
24	RS485_5B	
25	RS485_4A	Parallel RS485_4 communication (input)
26	RS485_4B	
27	RS485_4A	Parallel RS485_4 communication (output)
28	RS485_4B	
29	ATS-CAN205_H	Parallel communication CAN signal
30	ATS-CAN205_L	

### 6.5.4 Monitoring Device Terminal

The WIT inverter is equipped with a USB port that allows for remote monitoring when connected to a monitoring device, such as a USB-to-WiFi module, ShineWiFi-X, Shine4G-X, ShineLan-X, and others. Additionally, you can perform software updates using a USB flash drive.

1. Remove the waterproof cover from the USB port.
2. Insert the USB-to-WiFi module, ensuring that the triangle icon is facing upward, and then secure it by tightening the screw, as shown in Fig 6.14. If the module is working properly, its LED indicator will light up.

**NOTE:** Before you leave, please ensure that the monitoring device is removed and the protective cover should be reinstalled to avoid any water damage.

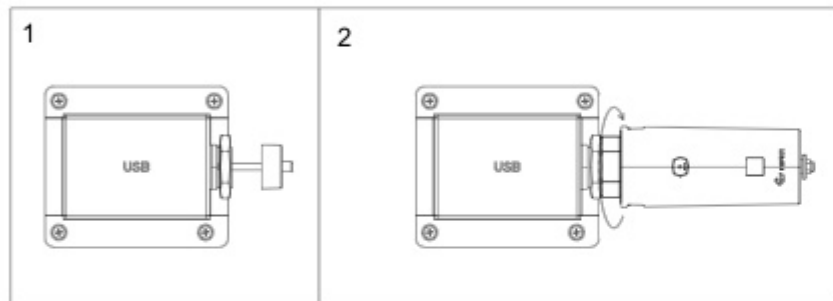

Fig 6.14 Connecting the monitoring device

### 6.5.5 DRMS Port

The WIT inverter comes with a DRMS port. Users can choose to connect to this terminal if required by local regulations. The connection procedure is as follows:

1. Connect the communication cable to the port as required. The DRMS port is a standard RJ45 connector, so you can establish a connection following the typical Ethernet wiring method.
2. Remove the dustproof cover from the DRMS port and check whether there is a waterproof silica gel pad. Insert the cable and tighten the rubber ring to prevent any loose connections.
3. Once the cable connection is complete, reinstall the dustproof cover.

Table 6.8 describes the DRM requirements.

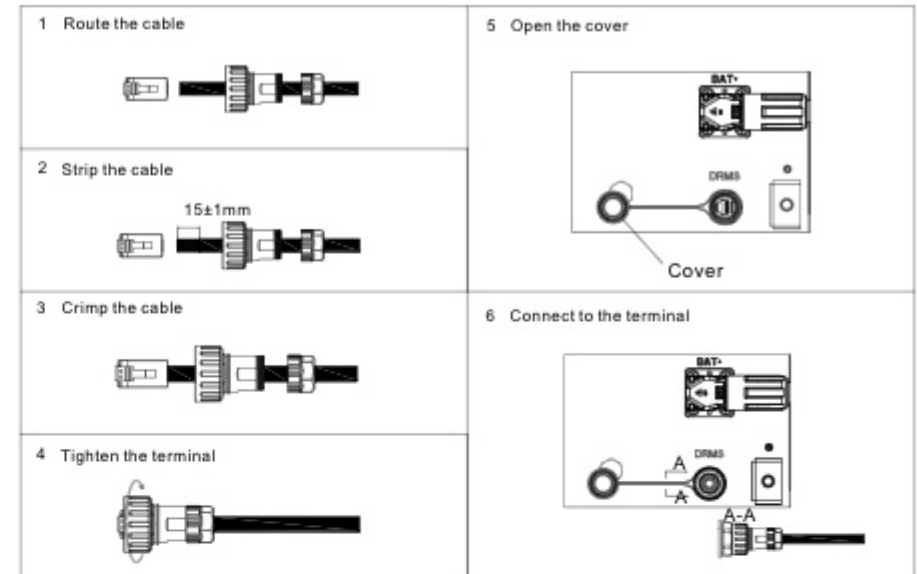

Fig 6.15 DRMS port

Table 6.8 Demand Response Modes (DRMs)

Mode	Socket asserted by shorting pins	Requirement
DRM0	5, 6	Operate the disconnection device
DRM1	1, 6	Do not consume power
DRM2	2, 6	Do not consume at more than 50% of rated power
DRM3	3, 6	Do not consume at more than 75% of rated power AND Source reactive power if capable
DRM4	4, 6	Increase power consumption (subject to constraints from other active DRMs)
DRM5	1, 5	Do not generate power
DRM6	2, 5	Do not generate at more than 50% of rated power
DRM7	3, 5	Do not generate at more than 75% of rated power AND Sink reactive power if capable
DRM8	4, 5	Increase power generation (subject to constraints from other active DRMs)



## 6.6 Post-installation Checks

The following table lists the post-installation items to be checked:

Position	Item	Check item
	Ground cable connected to the chassis	Check the cable specifications; ensure that the cable has been securely fastened
AC side	Ground cable on the AC side	Check the cable specifications; ensure that the cable has been securely fastened
	Grid side (-AE/-AU/-HE/-HU)	Check the cable specifications; ensure that the cable has been securely fastened
	Load side	Check the cable specifications; ensure that the cable has been securely fastened
	Waterproof silica gel pad	No gaps; the fireproof mud has been evenly applied
	AC junction box cover	Install the cover after the items on the AC side are checked
PV side	Ground cable on the PV side	Check the cable specifications; ensure that the cable has been securely fastened
	PV+/PV-	Check the cable specifications; ensure that the cable has been securely fastened; confirm that the number of PV modules matches the rated power
Battery side	Ground cable on the battery side	Check the cable specifications; ensure that the cable has been securely fastened
	BAT+/BAT-	Ensure that the positive and negative terminals are connected correctly and securely; the sealing rubber ring is properly seated into the gland
	BMS-AC	Ensure that the connection is correct and secured; the sealing rubber ring is properly seated into the gland
	Cable bundling	The cables are bundled in the specified position

Position	Item	Check item
Communication terminals	BMS-COM	Ensure that the connection is correct and secured; the sealing rubber ring is properly seated into the gland
	COM1	Ensure that the connection is correct and secured; the sealing rubber ring is properly seated into the gland
	COM2	Ensure that the connection is correct and secured; the sealing rubber ring is properly seated into the gland
	USB	Ensure that the connection is correct and secured; the sealing rubber ring is properly seated into the gland
	DRMS	Ensure that the connection is correct and secured; the sealing rubber ring is properly seated into the gland
Cover plate	Right cover plate	Reinstall the right cover plate after all the items are checked.

# 7 Commissioning

## 7.1 Powering on/off the System

1. Turn the DC switches on the WIT Inverter to the "ON" position.
2. Turn on the breaker between the grid and the inverter.
3. Turn on the breaker between the battery and the inverter, then turn on the switch on the battery to power it on.
4. Once the start-up requirements of all terminals are fulfilled, the system will be powered on automatically.

To shut down the system, please send a shutdown command on the APP or the webpage prior to performing any operations on the device. Then perform the steps in reverse order as described above.

APP:

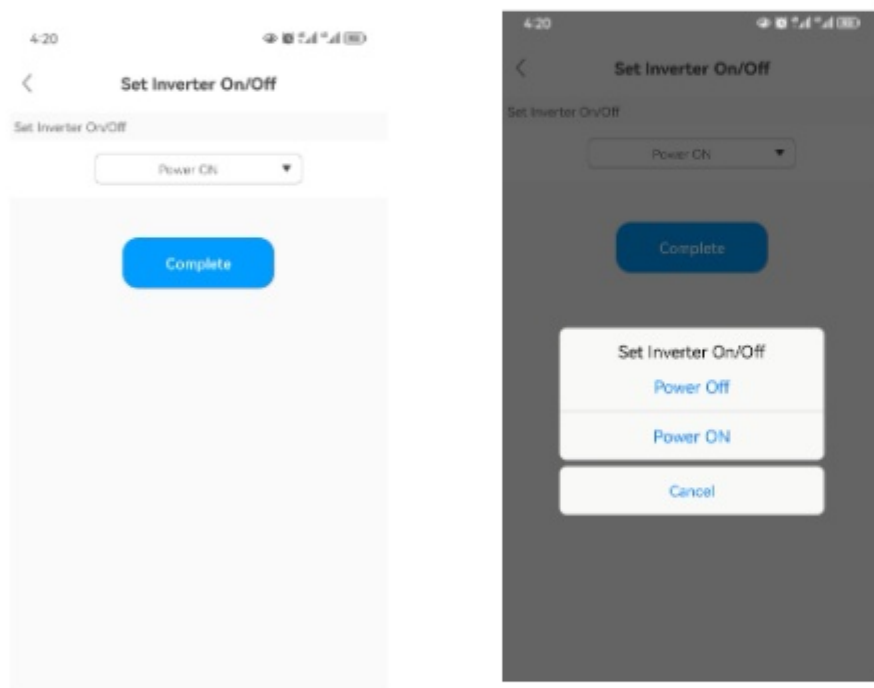

Webpage:

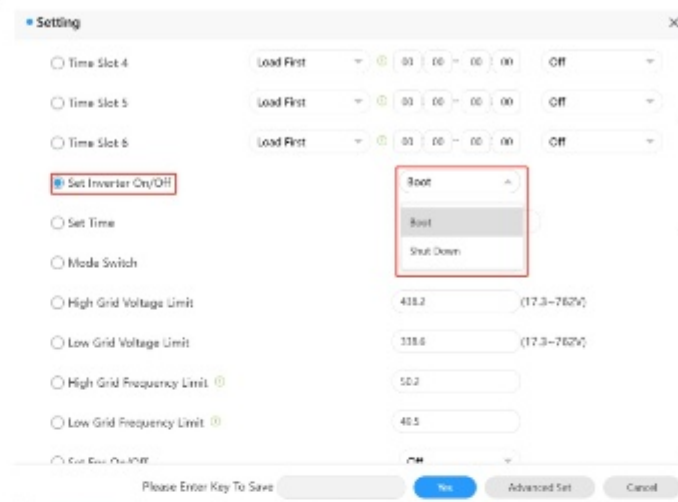

## 7.2 Commissioning the WIT Inverter



- The WIT Inverter might display incorrect time and date if it has been stored for over a month. You need to set the accurate time and date before connecting the WIT Inverter to the grid.

### 7.2.1 Set the Communication Address

After the WIT Inverter is powered on, you can set the communication address of the WIT Inverter through RS485 communication or the USB to Wi-Fi module. In cases where multiple inverters are connected in parallel with RS485 hand-in-hand communication, please assign different communication addresses to each inverter. For a single inverter, the communication address is set to 1 by default.

**NOTE:** The communication address of the WIT Inverter ranges from 1 to 254. By connecting the WIT Inverter to the host computer through RS458 communication, you can change its communication address via ShineBus. This operation should be performed by professional personnel.

### 7.2.2 Set the Time and Date

#### 7.2.2.1 Set the time and date on the APP

Follow the instructions in Section 6.5.4 to connect the datalogger. When the inverter is powered on, you can set inverter time and date referring to Section 8.1.1. Tap Control > Set Inverter Time, then enter the password "growatt+date". For instance, if the date is July 18, 2023, the password would be "growatt20230718". After that, tap "Yes".

1. Set the correct date, then click "OK". Proceed to set the time, and click "OK".

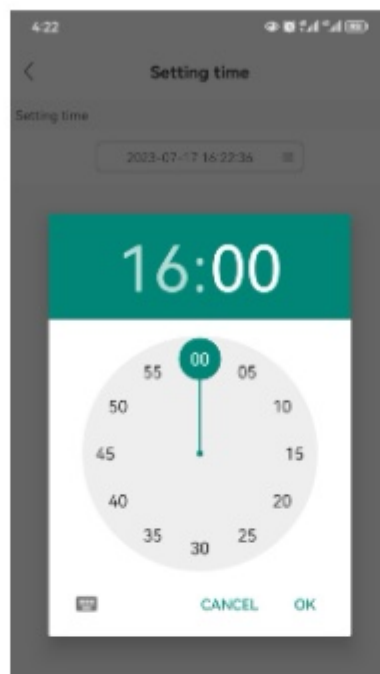
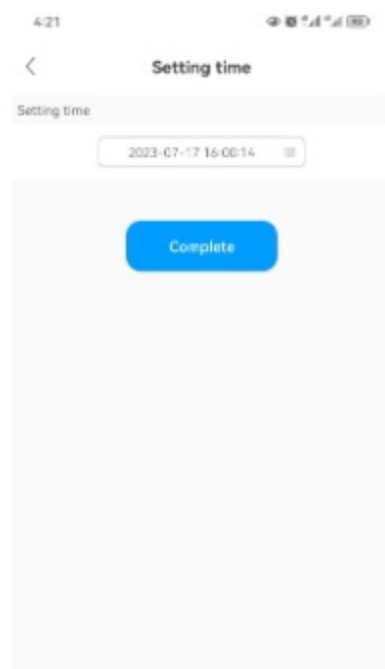

#### 7.2.2.2 Set the Date & Time Automatically

Connect the WIT Inverter to the server following the procedure specified in Section 8.1.2 when the inverter is powered on, then the WIT Inverter will update its date and time automatically.

## 7.3 Mode of operation

### 7.3.1 Waiting Mode

When the PV voltage is greater than 180V, the WIT Inverter will be powered on and enters the waiting mode.

In waiting mode, the WIT Inverter performs self-check. If the system is normal and the voltage is greater than or equals to 195V, the WIT Inverter will be powered on.

### 7.3.2 Operating Mode

#### 7.3.2.1 Operating Mode of WIT 50-100K-A, WIT 50-100K-AE and WIT 50-100K-AU

**Standby mode:** The WIT Inverter enters the standby mode when the operating requirements are not met.

**Charging mode:** Charge the battery from the grid (the AC Charging function should be enabled) You need to set this mode manually and configure the charging period and charging power.

**Discharging mode:** The battery discharges to supply power to the AC side You should set this mode manually and configure the discharging period and discharging power.

#### NOTE:

1. It is recommended to charge batteries with grid power during off-peak times and discharge battery power during peak hours to lower your electric bills.
2. The working modes listed above are applicable to the grid-tied power system. For the off-grid system, the WIT Inverter converts battery power to power the loads.

#### 7.3.2.2 Operating Mode of WIT 50-100K-H, WIT 50-100K-HE and WIT 50-100K-HU

##### Load First:

When the WIT inverter works in the Load First mode, the WIT storage unit controls the battery to charge and discharge according to the amount of electricity fed into the grid and drawn from the grid. When there is electricity fed into the grid, the WIT inverter adjusts this part of electricity to charge the battery, reducing the amount of electricity fed into the grid; when there is power from the grid, the WIT inverter adjusts the battery discharge to reduce the amount of electricity drawn from the grid. When the WIT inverter disable the Load First mode, it does not respond to the change of the power fed into the grid and taken from the grid. It will keep the battery power, and enters other priority modes.

##### Battery First:

When the WIT inverter works in this mode, the battery will ignore the forward and reverse current power and give priority to charging the battery. The user needs to set the mode ON and OFF time. If the customer does not enable AC CHG (AC power grid charging function), the WIT will charge the battery through PV power. If the customer enables AC CHG, the WIT will charge the battery through PV panel and the grid.

##### Grid First:

When the WIT inverter works in the Grid First mode, the load will be powered firstly, then export power to the grid. The user can choose to work in this mode when the electricity rate is high, and the user needs to set the on and off time of the mode.

### 7.3.3 Fault Mode

The intelligent control system of the WIT Inverter monitors and adjusts the system status in real time. When an alarm/fault is detected, the corresponding indicator will turn red and the OLED will display the error message. After the fault or alarm is cleared, the system recovers and all status indicators will be steady green.

**NOTE:** For details about faults and alarms, please see 9.2 Troubleshooting.

### 7.3.4 Shutdown Mode

When the battery SOC is lower than the discharge cutoff SOC and the PV string output power does not meet the requirements for grid-tied power generation, the WIT Inverter will automatically shut down. In shutdown mode, the inverter still consumes a small amount of energy (PV>Grid>Battery) while waiting to start up again when the operating requirements are met.

**NOTE:** When the DC input voltage is less than or equal to 150Vdc or the battery voltage is lower than 600V, the WIT Inverter enters the shutdown mode automatically.

## 7.4 LED and OLED Displays Panel

The LED and OLED display panel demonstrating the running status of the WIT Inverter is shown in the Fig 7.1. The symbol descriptions are provided in Table 7.1; The user interfaces are shown in Fig 7.2, and the LED indicator descriptions are available in Table 7.2.

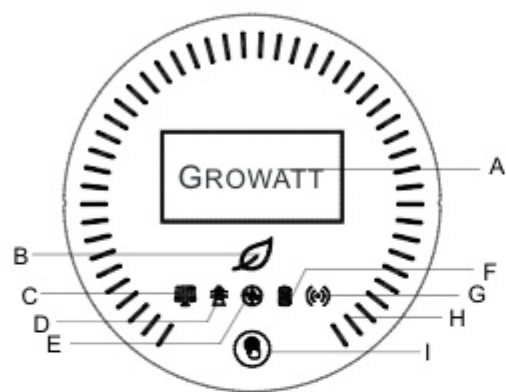

Fig 7.1 Display panel

Table 7.1 Symbol Description

Number	Description	Note
A	OLED screen	Displays the main system information
B	System indicator	Displays the system status
C	PV indicator	Indicates the operation status on the PV side
D	Grid indicator	Indicates the operation status on the grid side
E	Off-grid indicator	Indicates whether the off-grid mode is enabled
F	Battery indicator	Indicates the status of the battery
G	Communication indicator	Indicates the communication status
H	Battery status indicator	Indicates the charging and discharging mode of the battery
I	Button	You can switch the information displayed on the OLED by pressing the button

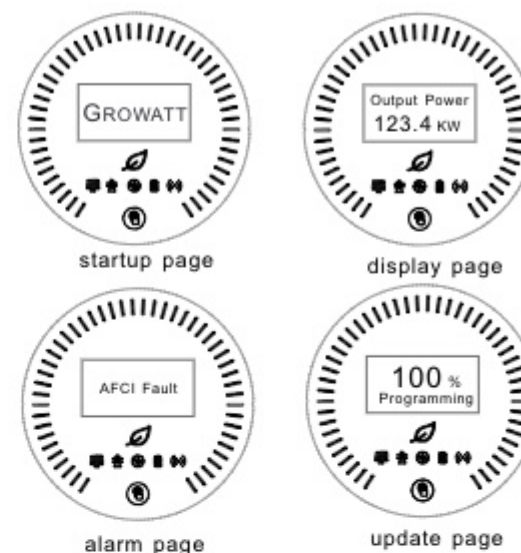

Fig 7.2 User interfaces

Table 7.2 Indicator description

	Status	Meaning
	Off	The system is not operating
	Steady green	The system is operating properly
	Blinking green at long intervals	The system is in standby mode or performing an upgrade
	Steady red	System failure
	Off	The PV voltage is below the operating voltage
	Steady green	The PV voltage reaches the operating voltage
	Steady red	A fault or alarm occurs on the PV side
	Off	The grid voltage is below the operating voltage
	Steady green	Successfully connected to the grid
	Steady red	A fault or alarm occurs on the grid side

	Status	Meaning
	Off	Off-grid mode is disabled
	Steady green	Off-grid mode is enabled and has no faults or alarms
	Steady red	Off-grid mode is enabled and a fault or alarm occurs on the AC side
	Off	The battery voltage is below the operating voltage
	Steady green	The battery voltage reaches the operating voltage
	Steady red	SOC (state of charge) is low; a fault or alarm occurs on the battery side
	Steady green	External communication is normal, such as RS485, Wi-Fi, 4G, etc.
	Blinking green at long intervals	The WIT Inverter is upgrading or the USB interface is reading and writing data
	Steady red	External communication fails or a system fault occurs
	Steady white	Battery is in standby mode
	Rotates clockwise	Charging mode
	Rotates anticlockwise	Discharging mode
	Displays critical system information. Users can call up and switch the interface by tapping the button. When a fault or alarm occurs in the system, the fault or alarm will be displayed.	
	The OLED will wake up when the button is pressed. The OLED will turn off if there is no operation for 5 minutes.	

## 8.1 Remote Monitoring

Growatt WIT 50-100K Storage/Hybrid inverters support remote monitoring, which can be enabled by installing a datalogger. The operation and configuration methods vary based on different datalogger models. For details, please refer to the links below.

Compatible Datalogger	Installation & Operation Guide Linkage
ShineWiFi-X	<a href="http://oss-eu.growatt.com/common/knowledgeShareH5No?lang=en&amp;type=93">http://oss-eu.growatt.com/common/knowledgeShareH5No?lang=en&amp;type=93</a>
ShineWiFi-X2	<a href="http://oss-eu.growatt.com/common/knowledgeShareH5No?lang=en&amp;type=94">http://oss-eu.growatt.com/common/knowledgeShareH5No?lang=en&amp;type=94</a>
Shine4G-X	<a href="http://oss-eu.growatt.com/common/knowledgeShareH5No?lang=en&amp;type=96">http://oss-eu.growatt.com/common/knowledgeShareH5No?lang=en&amp;type=96</a>
Shine4G-X2	<a href="http://oss-eu.growatt.com/common/knowledgeShareH5No?lang=en&amp;type=97">http://oss-eu.growatt.com/common/knowledgeShareH5No?lang=en&amp;type=97</a>
ShineLAN-X	<a href="http://oss-eu.growatt.com/common/knowledgeShareH5No?lang=en&amp;type=95">http://oss-eu.growatt.com/common/knowledgeShareH5No?lang=en&amp;type=95</a>

### 8.1.1 Remote Monitoring on the APP (ShinePhone)

1. Scan the following QR code or search for "ShinePhone" in Google/Apple Store to download and install the mobile APP.



#### NOTE:

- (1) Download and install the latest version of ShinePhone.
- (2) See <https://server-us.growatt.com/?lang=en> for details.

#### Account Registration on ShinePhone

Run the APP and tap "Create account" on the login page. Fill in the information as required. Fields marked with \* are mandatory. Tick the checkbox to agree to the Privacy Policy. Once the account is successfully registered, you can log in to the home screen. The registration page is shown below:

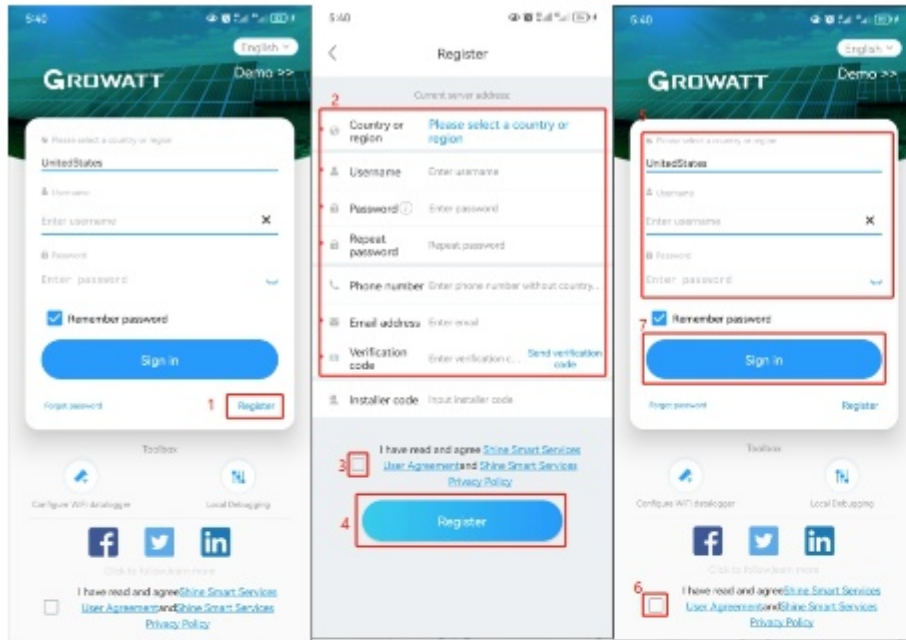

### Home Screen of ShinePhone

1. **Dashboard:** displays the critical information of all power plants under the account, such as the total yield, the total revenue and the status of the device. Please refer to the figures below:

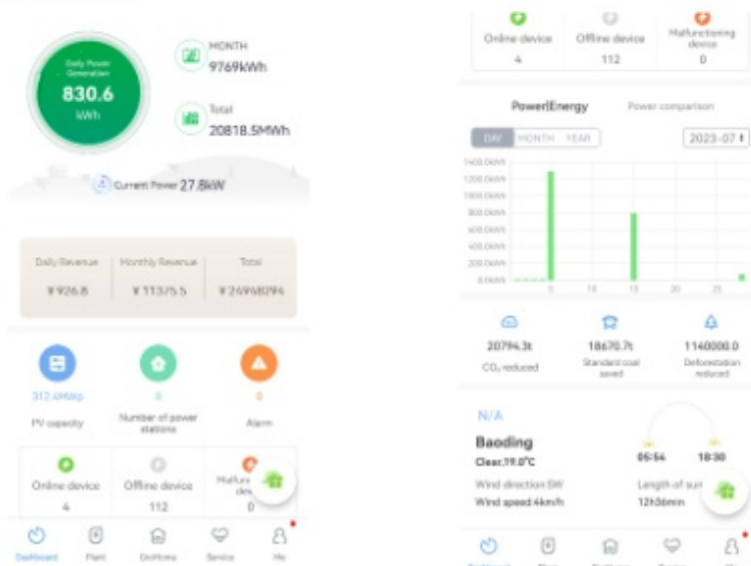

2. **Plant:** displays the plant list and the basic information about each PV plant, as shown in the figure below. You can select your target plant to view detailed information.



### Detail Page of the WIT Inverter:

To access details about the WIT Inverter or related devices:

- (1) Tap "Plant" and the "Plant List" will be displayed. Select your target plant, then you can access the real-time data and history record of the power plant;
- (2) Select the WIT Inverter marked with its SN from "My device list". The figures below show QWL0DC3008 as an example;
- (3) On the Detail Page, you can view information about the inverter and related devices. Three sections - "Events", "Control" and "Edit", are available at the bottom.

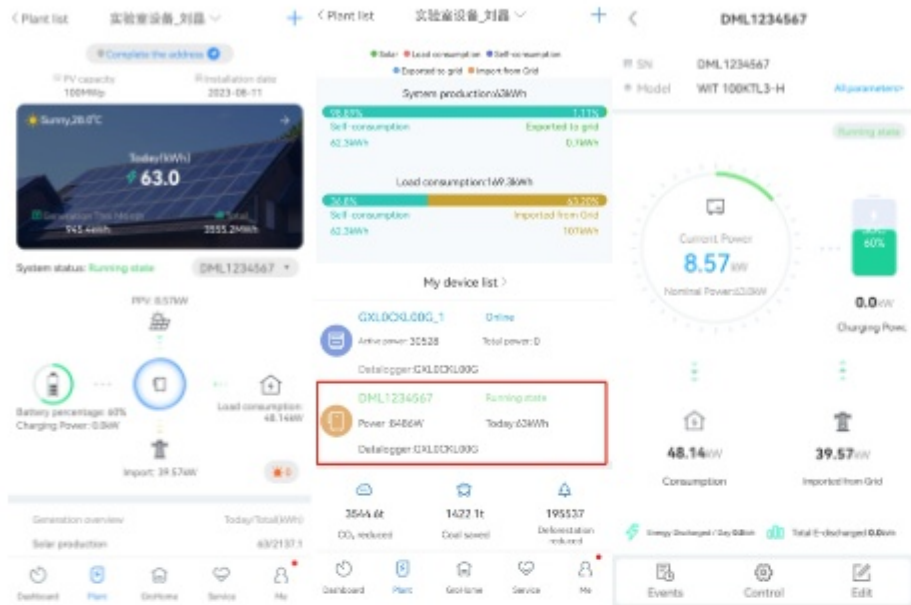

(4) On the "Log" screen, you can view the fault/warning message and suggested troubleshooting measures.



(5) On the "Control" screen, you can configure the WIT Inverter. The password is in the format of "Growatt + the current date", e.g. Growatt20230718.

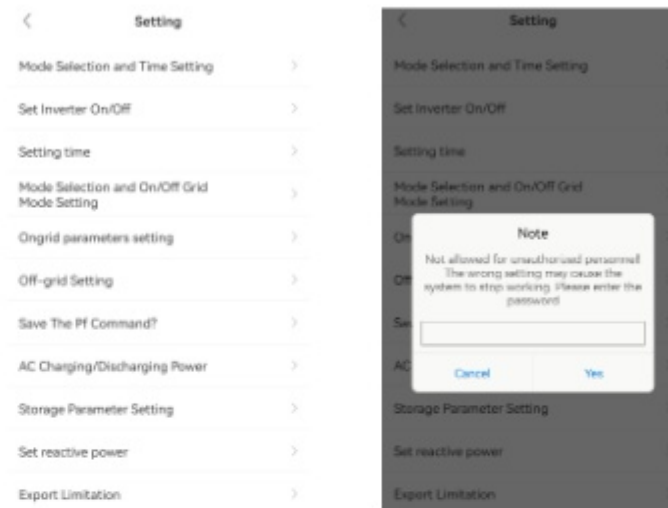

> **Set Working Modes for Different Time Periods**  
Tap Control > Mode Selection and Time Setting; 6 time segments are configurable. You can set the start and end time of each period, the corresponding working mode, including Load First, Battery First and Grid First, and whether to enable/disable the selected working mode. Choose the appropriate working mode considering the corresponding electricity rates and power consumption during the specific time period.

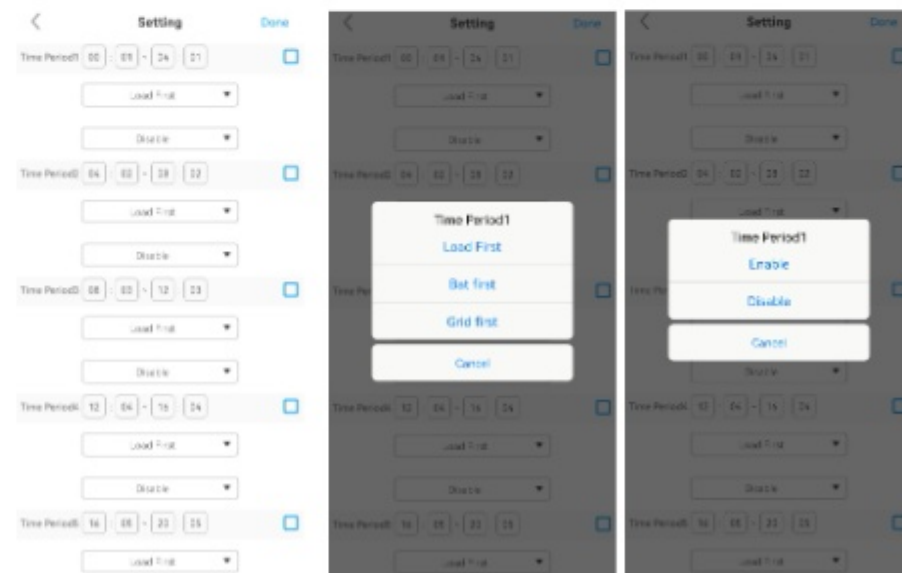

➤ **Set Inverter On/Off**

Tap Control > Set Inverter On/Off; you can power on/off the inverter, as the figure shows.

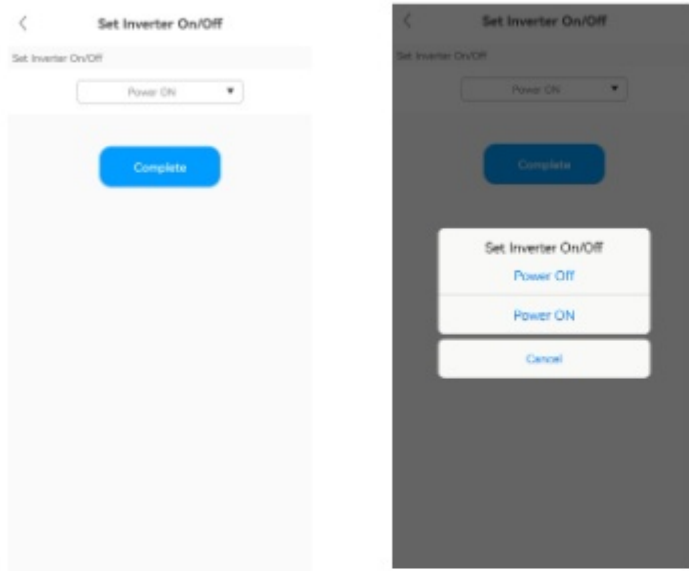

➤ **Set the Working Mode and the On-/Off-grid mode**

Tap Control > Mode selection and On/off grid mode setting. Two options are available: Automatic mode and Manual mode. If the Manual mode is selected, you can set the inverter to work in the on-grid or off-grid mode, as the figure shows. The Automatic Mode is recommended.

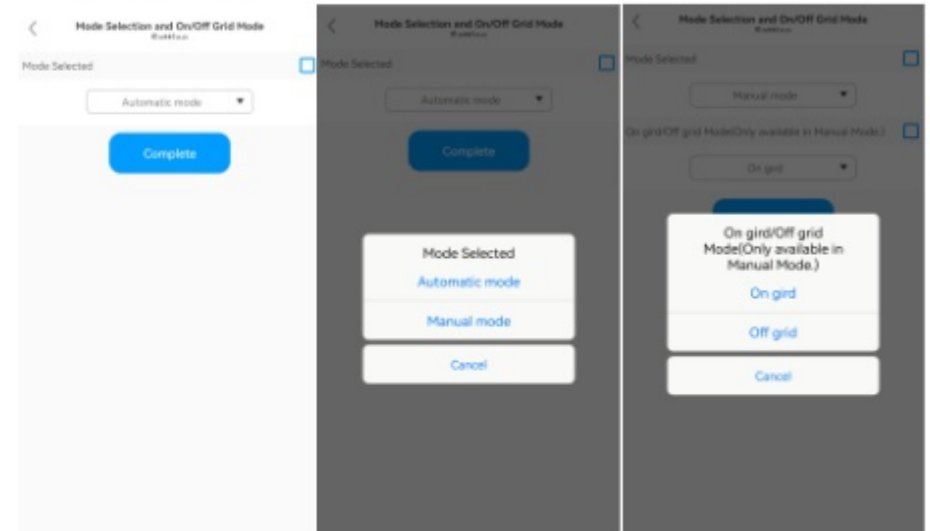

➤ **Set the Time of the Inverter**

Tap Control > Set Inverter Time; you can set the local time, as the figure shows.

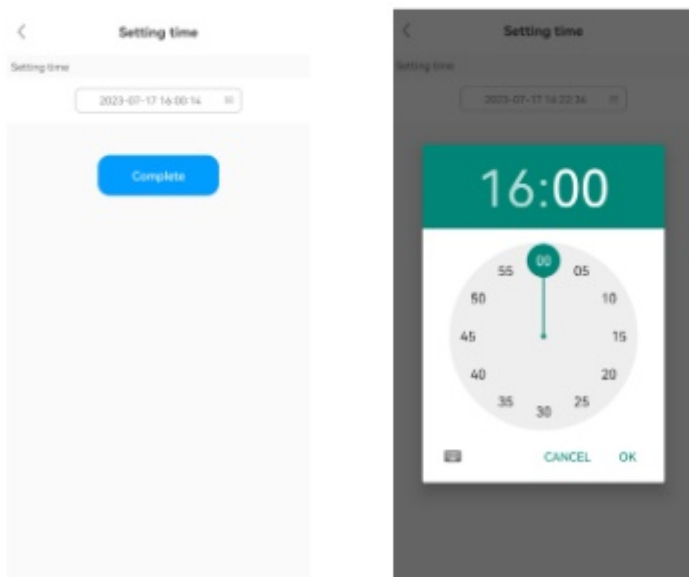

➤ **Set the Grid Parameters**

Tap Control > Grid parameters, you can set the voltage upper/lower threshold of grid connection and the frequency upper/lower threshold of grid connection, as the figure shows.





➤ **Set the Off-grid Parameters**

Tap Control > Off-grid Setting, you can enable/disable the off-grid mode, set the off-grid frequency (50Hz/60Hz) and the off-grid voltage (220V/230V/240V/277V/127V), complying with the safety regulations.

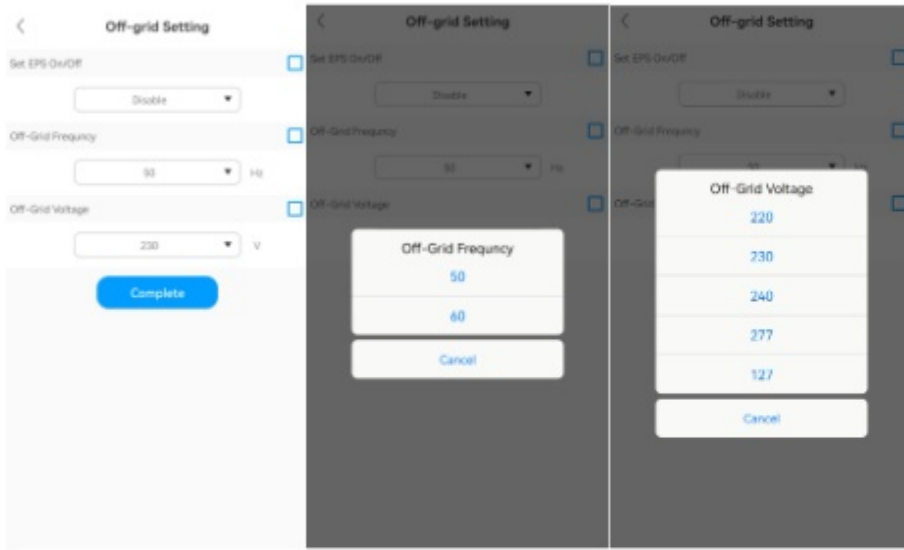

➤ **Set Whether to Apply the Following PF Command**

Tap Control > Whether to apply the following PF command, you can select whether to apply the following PF command, as the figure shows.

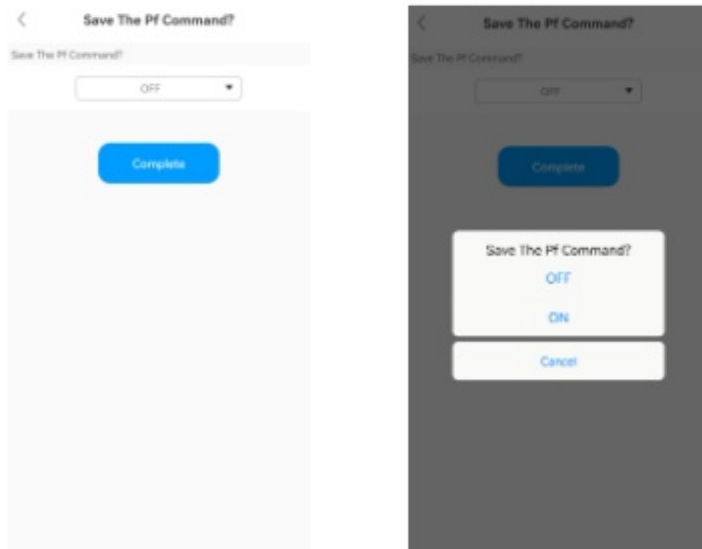

➤ **Set AC Charging and Discharging Power**

Tap Control > AC Charging and Discharging Power, you can configure the AC charging/discharging power and choose whether to remember your settings, as the figure shows.

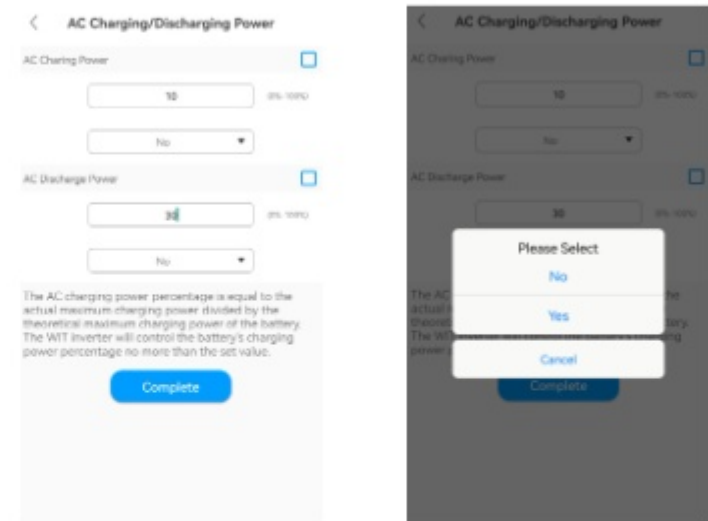

➤ **Set the Storage Parameters**

Tap Control > Storage Parameter Setting, you can enable/disable the AC charging function (Charge from grid), the charging cutoff SOC (100 is recommended) and the discharging cutoff SOC (10 is recommended), as the figure shows.

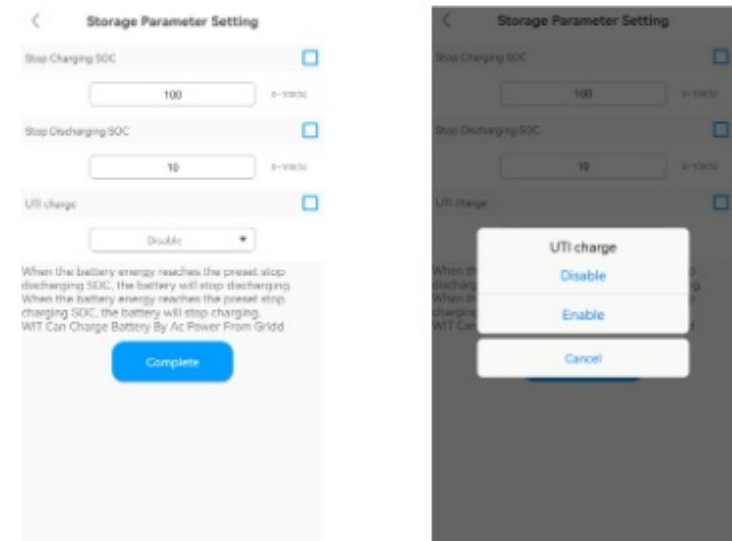

➤ **Set the Reactive Power**

Tap Control > Set reactive power, you can select the corresponding PF mode and whether to remember your settings, as the figure shows.

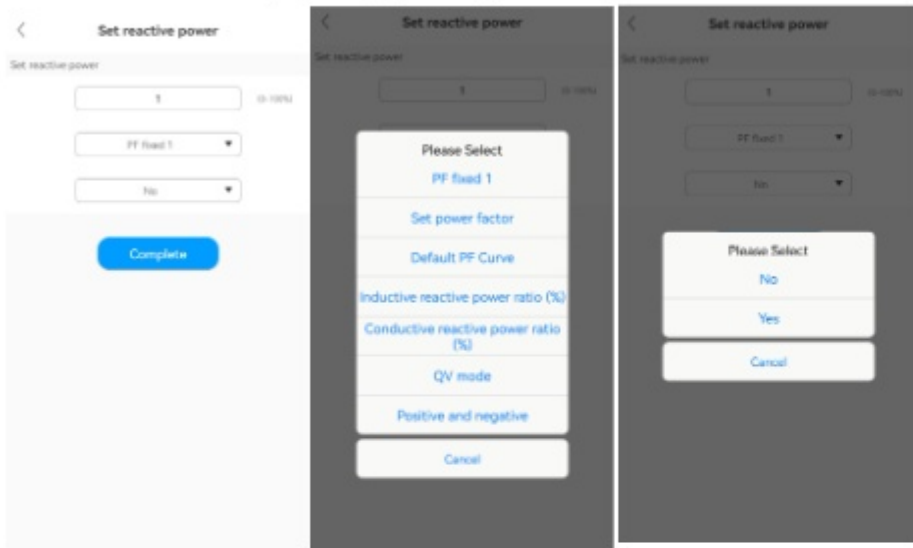

➤ **Set the Single-phase Export Limitation**

Tap Control > Single Export, you can enable/disable the single-phase export limitation function, as the figure shows.

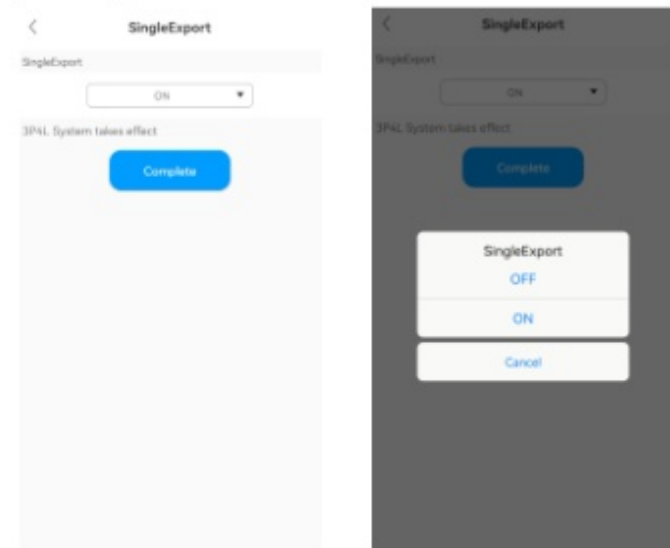

➤ **Set the Export Limitation Parameters**

Tap Control > Export Limitation, you can enable/disable the export limitation function according to local regulations. If the Export Limitation function is enabled, you can set the Export power limit, as the figure shows.

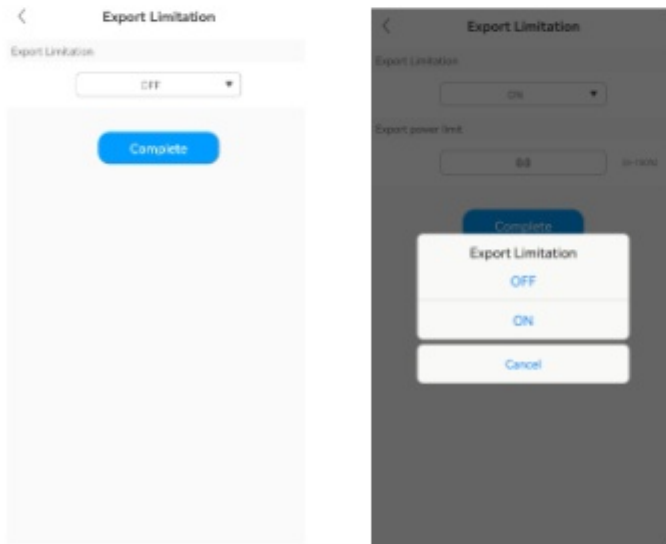

➤ **Set the Power Factor**

Tap Control > Set power factor, you can set the PF value, ranging from -1 to 1, as the figure shows.



➤ **Set the Maximum Charging/Discharging Current**

Tap Control > Max. Charging/Discharging Current, you can set the maximum charging/discharging current, ranging from 0 to 200A, as the figure shows.

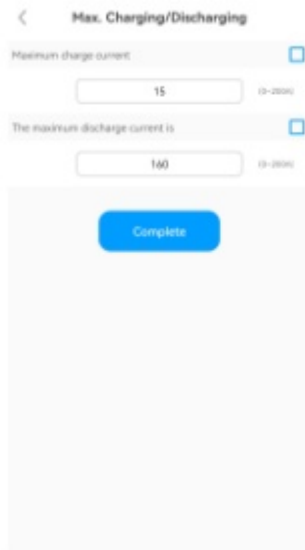

➤ **Set the EOD voltage**

Tap Control > EOD Voltage, you can set the battery discharge cutoff voltage, ranging from 600 V to 1000V, as the figure shows.



➤ **Set the Equalization Voltage**

Tap Control > Equalization Voltage, you can set the battery maximum charging voltage, ranging from 600 V to 1000V, as the figure shows.

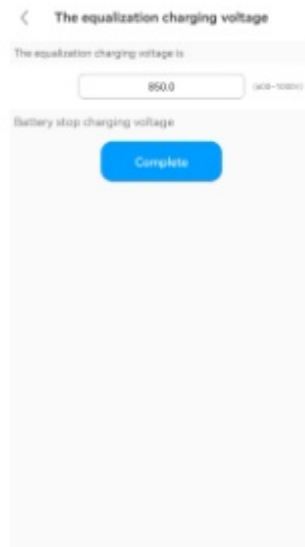

➤ **Set the Customized PF Curve**

Tap Control > Custom PF curve, you can set the power percentage and the power factor of each point, as the figure shows.



(6) Edit: you can change the device name as the figure shows.

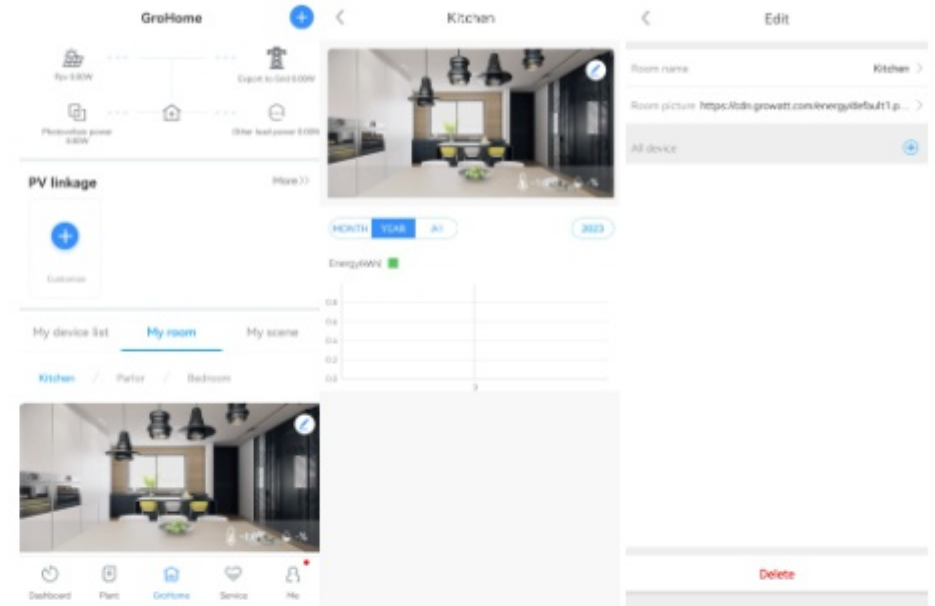
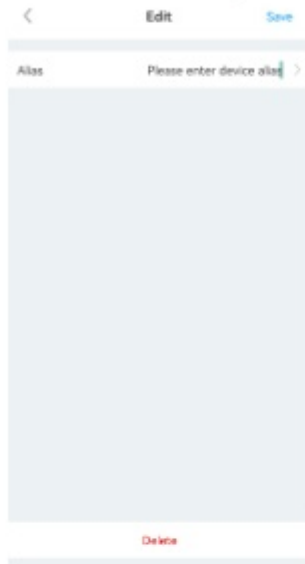

3. GroHome: displays the home energy system, including four sections: "PV linkage", "My device list", "My room" and "My scenario".

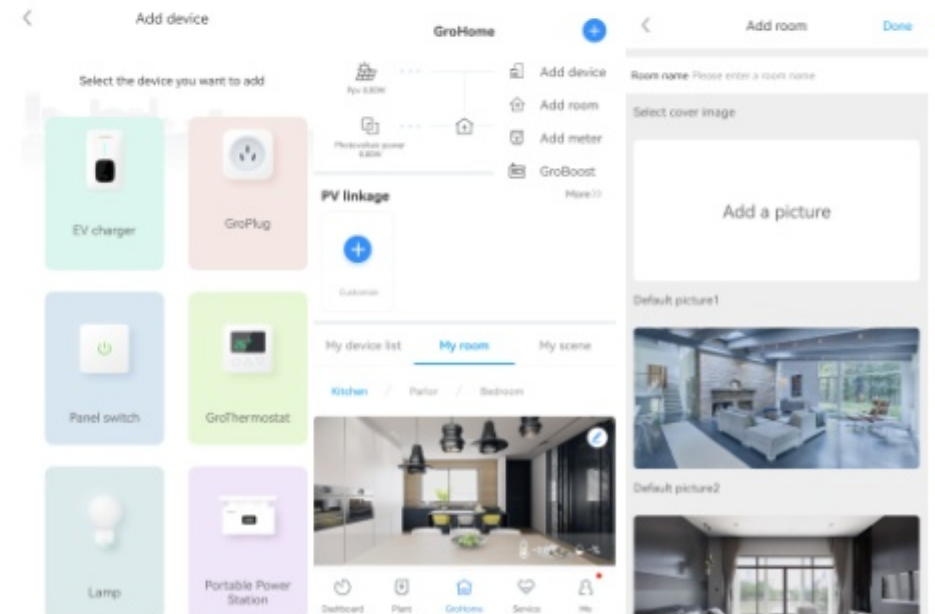
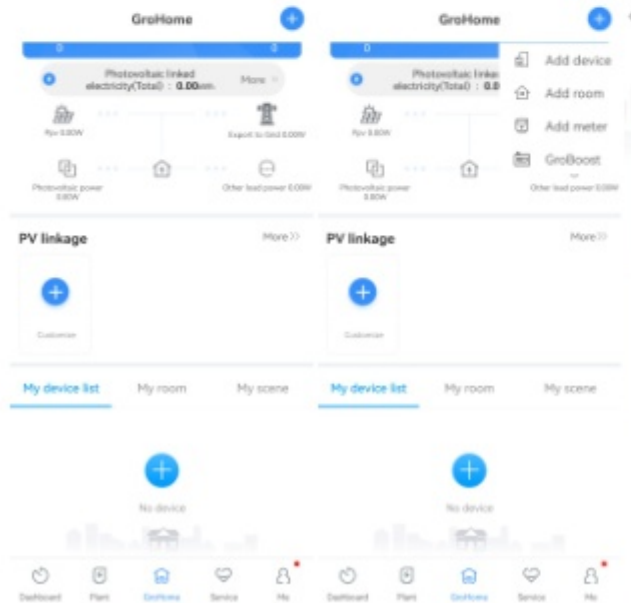

4. **Support:** includes the common faults and troubleshooting suggestions, as shown in the figure below. Should you encounter any problem about our product, you can contact the Growatt after-sales support or refer to the related document.

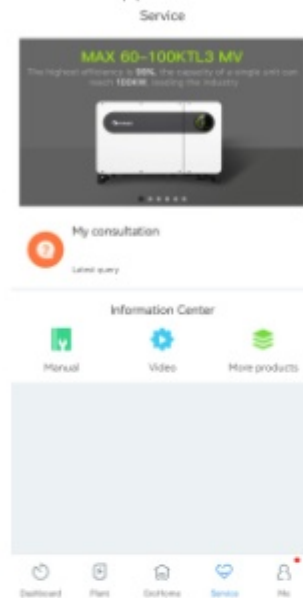

5. **Me:** You can check the account information, configure the datalogger or view notifications, as shown in the figure below.

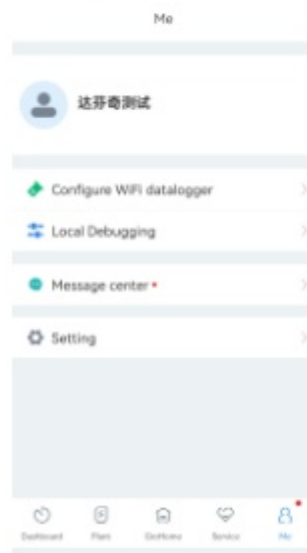

### 8.1.2 Remote Monitoring on the ShineServer Webpage

1. Open the browser, then enter <https://server.growatt.com/login?lang=en> in the address box to access the login page. Click "Register an Account" if you do not have an account.

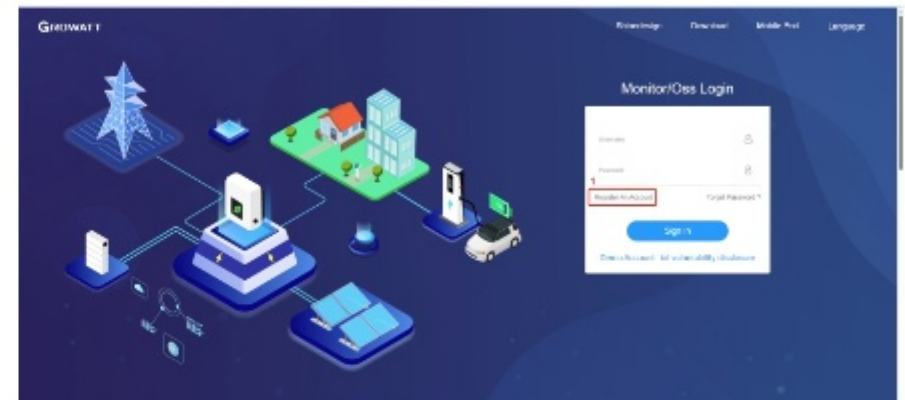

2. After the Registration Page is displayed, fill in the information as required and click to agree to the Privacy Policy. Fields marked with the "." icon are mandatory. Click next, it will bring you to the "Add Plant" page. Then click "Back to Login" on the top right corner.

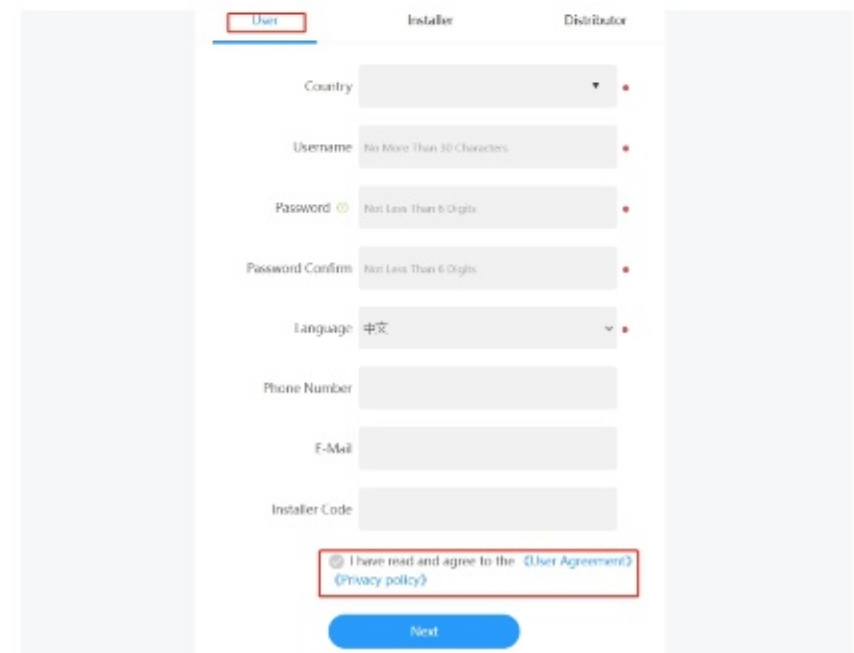



3. On the Login screen, enter the username and the password to log in to the home screen.

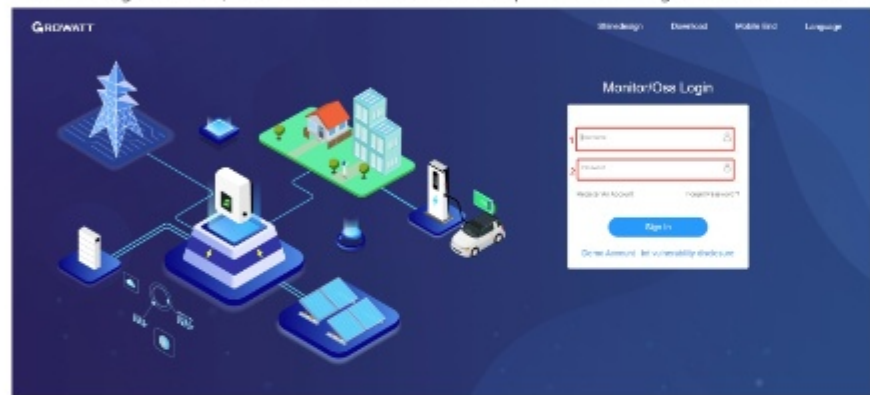

4. After accessing the home screen, the "Add Plant" window will pop up. Fill in the information as required (marked with ".") and click "Yes". If the plant has been created, you can select the target plant on the home screen.

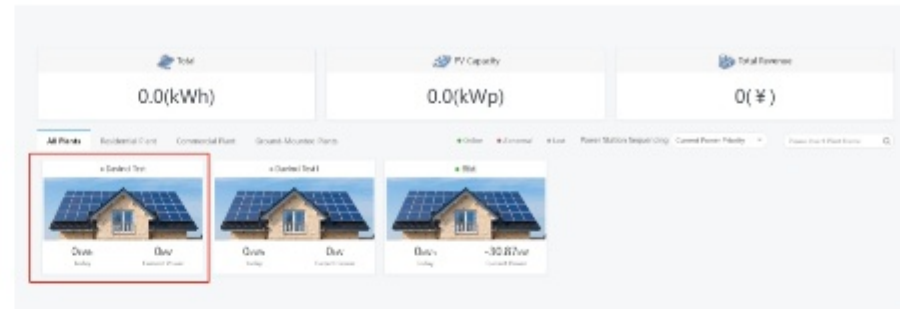
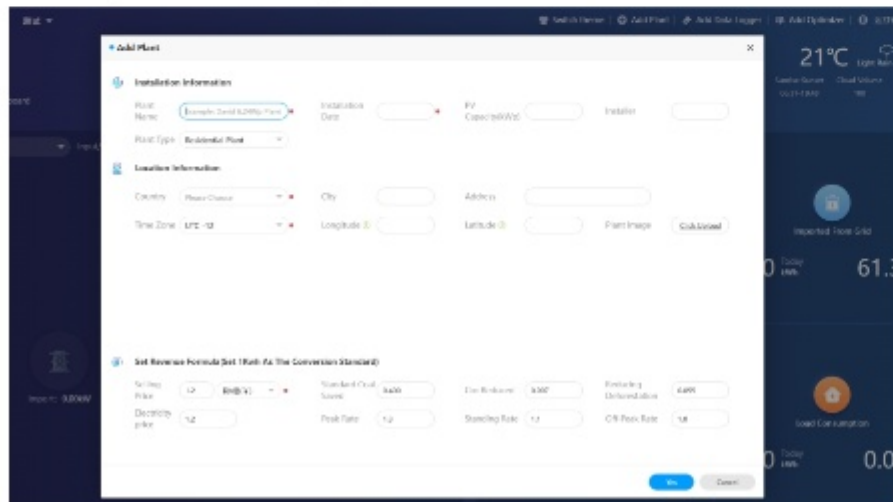

5. Click the target plant and the detailed page will be displayed, click "Add Data Logger" on the upper right corner to add the datalogger connected to the inverter.  
 1) Enter the serial number (SN) of the datalogger  
 2) Enter the verification code of the datalogger

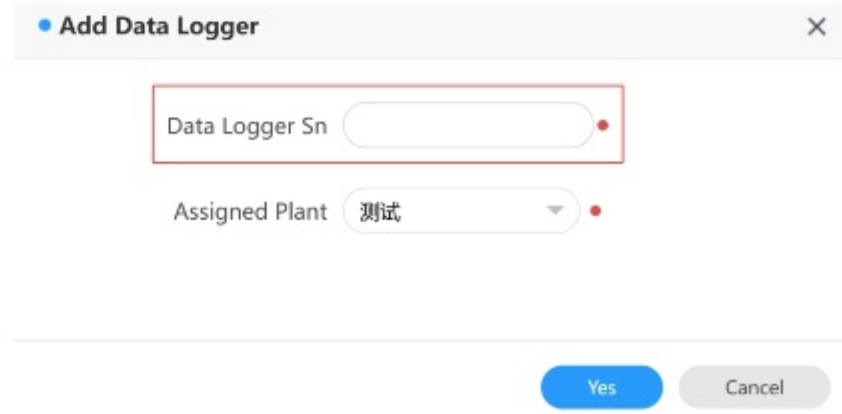
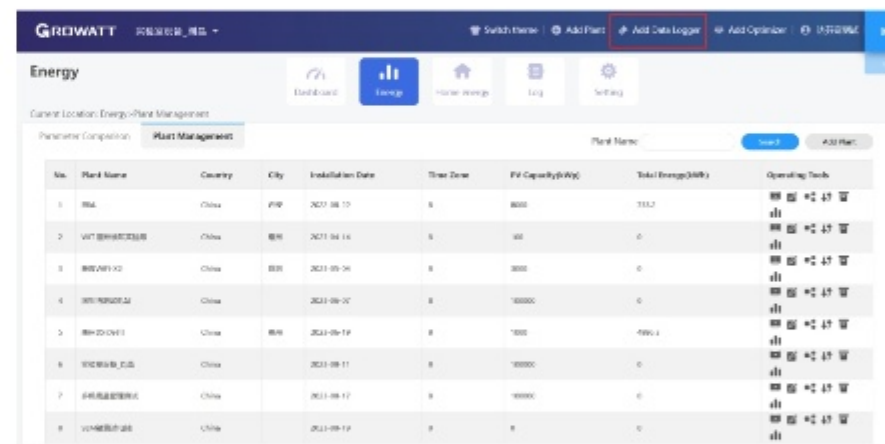

6. After adding the datalogger successfully, you can click Dashboard to view details about related devices.



Dashboard:

### 1. Running status and energy display

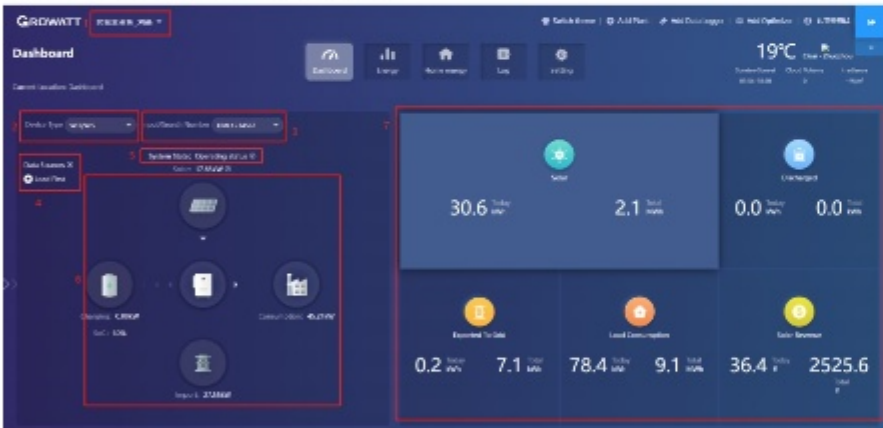

- 1) Plant List: select the target plant from the drop-down list
- 2) Device Type: Select the device from the drop-down list
- 3) Input/Search Number: Upon the initial search, enter the serial number of the specific device; If you have searched for it before, you can select the device from the drop-down list
- 4) Data Sources: displays the data source of the selected device: Load First, Battery First and Grid first
- 5) System Status: displays the running status of the selected device: operating, faulty, standby and off-line
- 6) System Running Graph: displays the power flow between the PV modules, the battery and the AC side
- 7) Energy: displays today's/total PV generation, power imported from grid, power exported to the grid and the load consumption

### 2. Energy Trend

- 1) System Production: displays the power for self-consumption and the power exported to the grid
- 2) Date: select a specific date, you can view the energy data in a specific period, day, month or year
- 3) Load Consumption: displays the power for self-consumption and the power drawn from the grid
- 4) Display options: to show/hide the content by clicking the corresponding color circle. By placing the cursor on the specific color circle for a long period, it will display the energy trend of the selected item only

### 3. Battery Information



- 1) Battery charged and discharged: display the battery charge and discharge power
- 2) Battery real-time SOC: display the battery SOC

### 4. My PV devices

This section displays all devices involved in the selected PV plant (online devices are shown first, followed by offline devices).

### Energy

#### 1. Parameter comparison

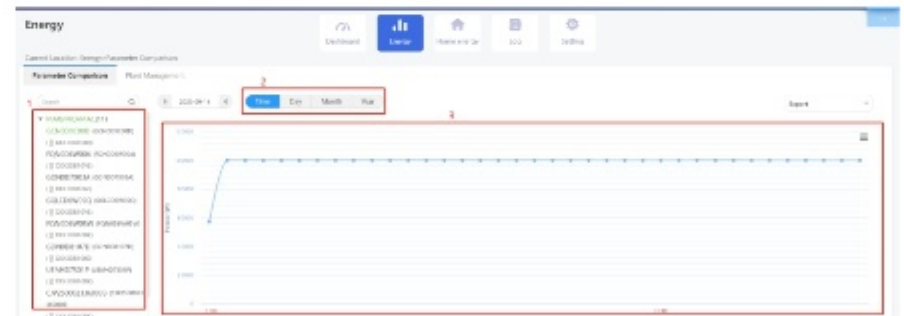

- 1) Device type: Select the device type for comparison, such as the WIT inverter or the meter
- 2) Date: select a specific date, you can view the energy data in a specific period, day, month or year.

## 2. Plant Management

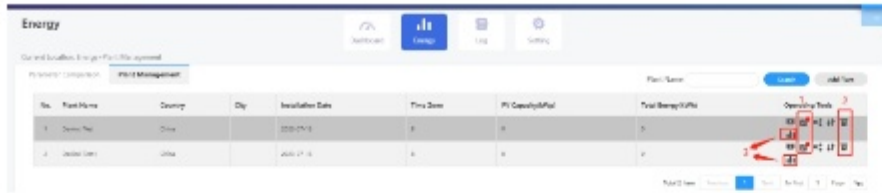

Click Plant Management and you can view all PV plants associated with the current account.

- 1) Edit: Click the "Edit" icon (indicated in the figure above) to modify the PV plant information
- 2) Delete: Click the "Delete" icon (indicated in the figure above) to delete the selected PV plant
- 3) Data: Click the "Data" icon (indicated in the figure above) to view the energy yield and power of the selected plant

## Log

On the Log page, you can view the error code and the fault description.



## Setting

### 1. Account management

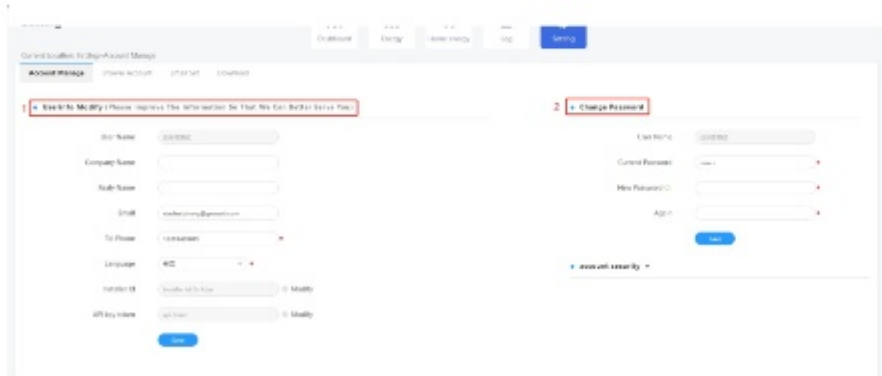

- 1) Modify your account information
- 2) Change the password: you can change the password on this page

## 2. Download

A range of documents are available for download.

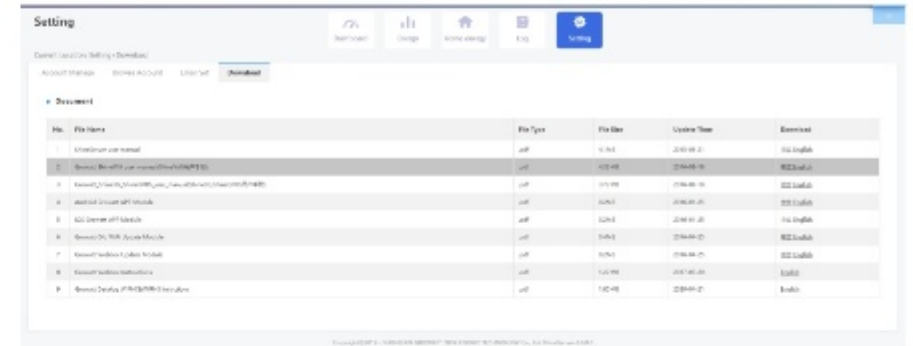

## Device

### 1. Datalogger

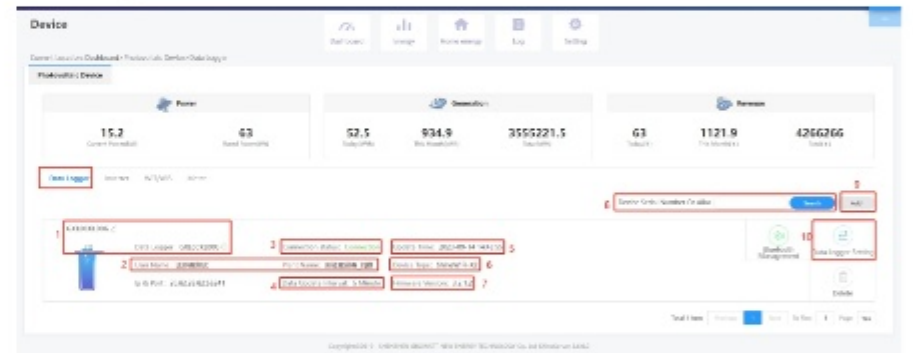

- 1) Serial number: each datalogger has a specific SN, which can be used to search for the device;
- 2) User name and the PV plant to which the datalogger is connected;
- 3) Connection status: connected or disconnected;
- 4) Data update interval;
- 5) Update time;
- 6) Device type;
- 7) Firmware version;
- 8) Enter the serial number to search for the target datalogger;
- 9) Add a datalogger: enter the serial number to add the datalogger;
- 10) Datalogger settings: you can set the update time for the datalogger;



## 2. WIT

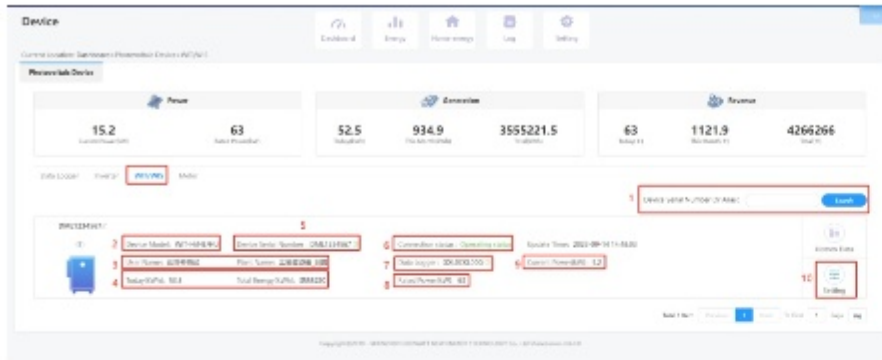

- 1) Enter the serial number to find the device;
  - 2) Device model;
  - 3) User name and the PV plant to which the device is connected;
  - 4) Daily and monthly energy yield;
  - 5) Serial number of the selected device;
  - 6) Operating status: operating, standby, disconnected or faulty;
  - 7) Serial number of the datalogger connected to the device;
  - 8) Rated power;
  - 9) Current power;
  - 10) Parameter settings.
- 10.1) Set the working mode and the time period

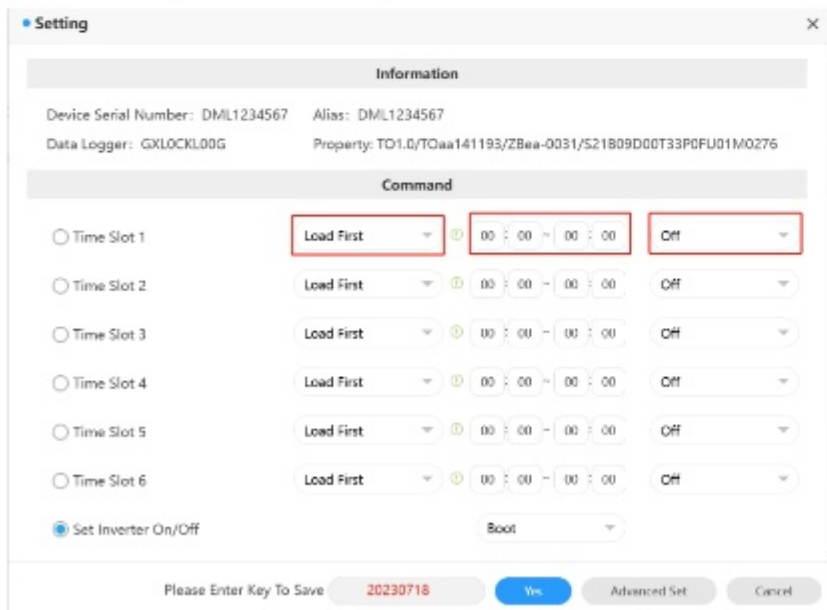

10.2) Powering on/off the device: you can power on/off the device remotely

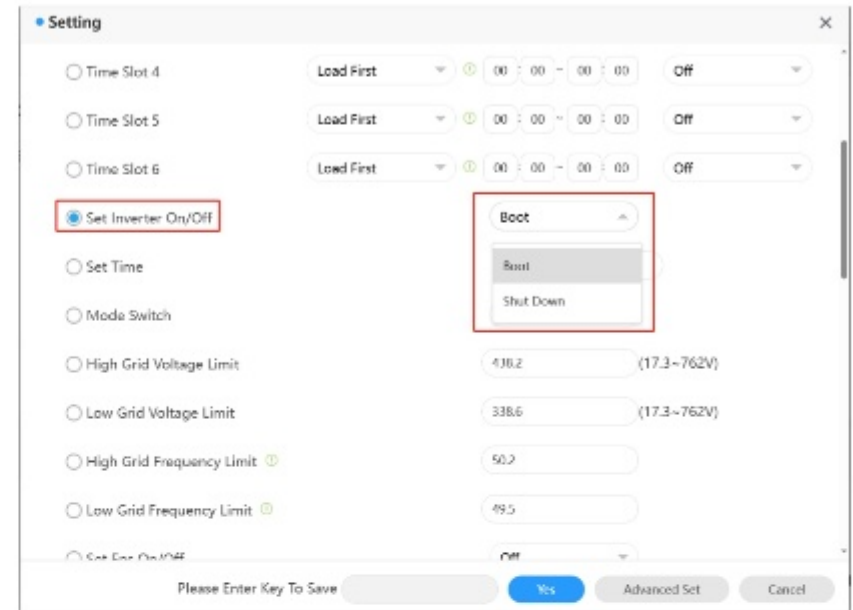

10.3) Set the time: you can set the time for the device

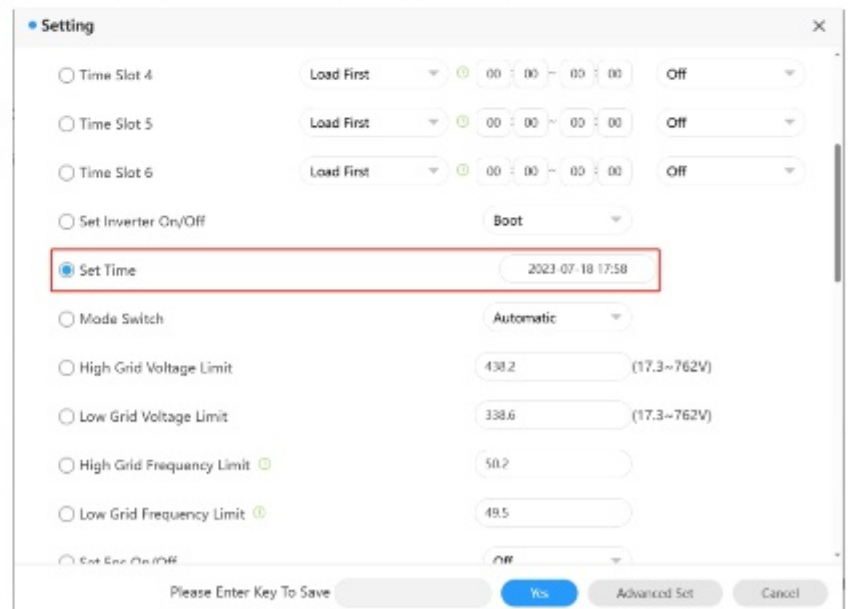

10.4) Mode switch: you can choose to switch the working mode manually or automatically. If "Manual" is selected, you can set the device to operate in on-grid or off-grid mode. Generally, you are advised to select "Automatic" mode switch.

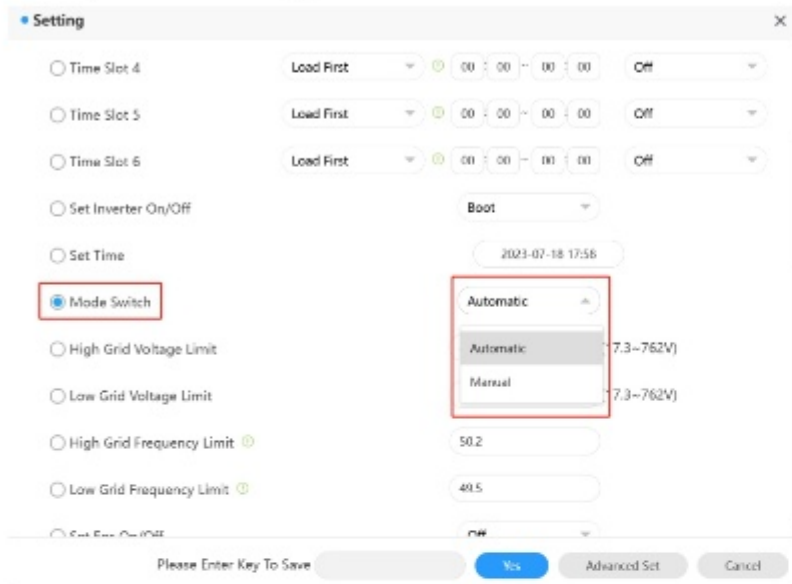

10.5) High grid voltage limit (voltage upper threshold of grid connection)

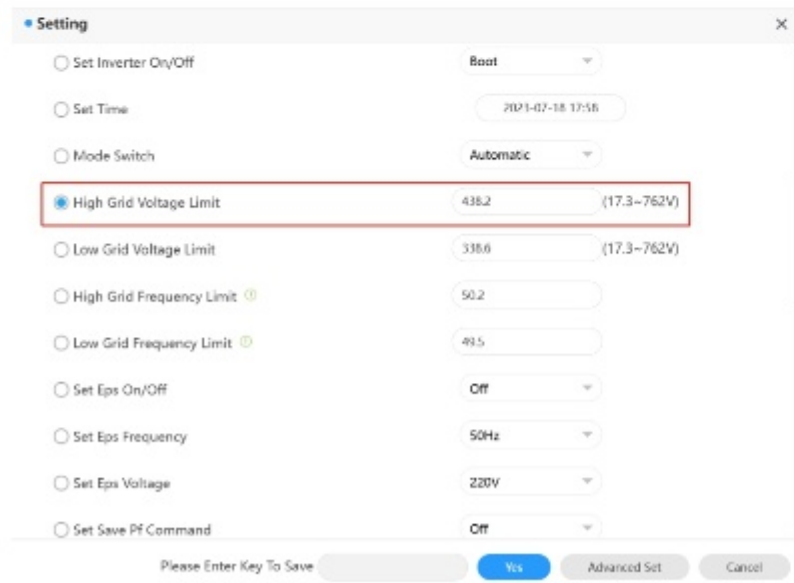

10.6) Low grid voltage limit (voltage lower threshold of grid connection)

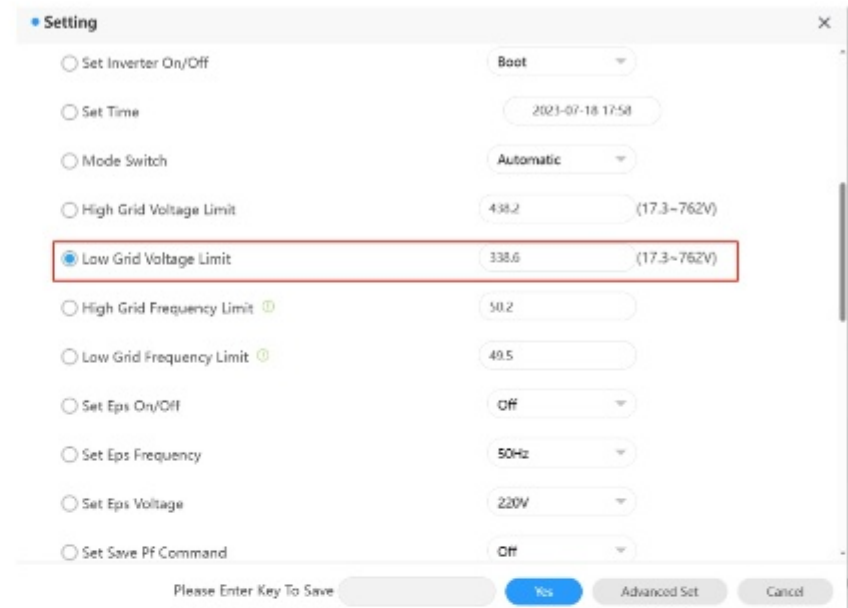

10.7) High grid frequency limit (frequency upper threshold of grid connection)

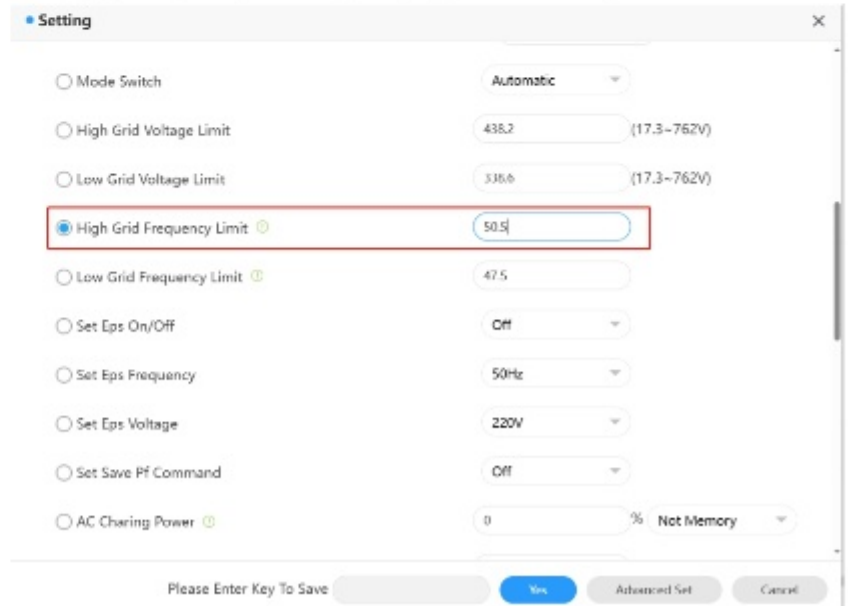

10.8) Low grid frequency limit (frequency lower threshold of grid connection)

Setting

- Mode Switch: Automatic
- High Grid Voltage Limit: 430.2 (17.3~762V)
- Low Grid Voltage Limit: 338.6 (17.3~762V)
- High Grid Frequency Limit: 50.5
- Low Grid Frequency Limit: 47.5**
- Set Eps On/Off: Off
- Set Eps Frequency: 50Hz
- Set Eps Voltage: 220V
- Set Save Pf Command: Off
- AC Charing Power: 0 % Not Memory

Please Enter Key To Save Yes Advanced Set Cancel

10.10) Off-grid frequency: two options are available: 50Hz/60Hz

Setting

- High Grid Frequency Limit: 50.5
- Low Grid Frequency Limit: 47.5
- Set Eps On/Off: Off
- Set Eps Frequency: 50Hz**
- Set Eps Voltage
- Set Save Pf Command
- AC Charing Power: 0 % Not Memory
- Charge Stopped Soc: 100 %
- Ac Charge: Off
- AC Discharge Power: 100 % Not Memory

Please Enter Key To Save Yes Advanced Set Cancel

10.9) Set off-grid mode on/off: you can set whether to operate the inverter in the off-grid mode

Setting

- High Grid Frequency Limit: 50.5
- Low Grid Frequency Limit: 47.5
- Set Eps On/Off: Off**
- Set Eps Frequency
- Set Eps Voltage
- Set Save Pf Command: Off
- AC Charing Power: 0 % Not Memory
- Charge Stopped Soc: 100 %
- Ac Charge: Off
- AC Discharge Power: 100 % Not Memory

Please Enter Key To Save Yes Advanced Set Cancel

10.11) Off-grid voltage: you can set the value to 220V/230V/240V/277V/127V

Setting

- High Grid Frequency Limit: 50.5
- Low Grid Frequency Limit: 47.5
- Set Eps On/Off: Off
- Set Eps Frequency: 50Hz
- Set Eps Voltage: 220V**
- Set Save Pf Command
- AC Charing Power: 0 % Not Memory
- Charge Stopped Soc
- Ac Charge
- AC Discharge Power: 100 % Not Memory

Please Enter Key To Save Yes Advanced Set Cancel

10.12) Save the PF Command: you can set whether to save the PF command setting

The screenshot shows the 'Setting' dialog box with the 'Set Save PF Command' option selected and highlighted with a red box. The dropdown menu is open, showing 'Off' as the selected option, also highlighted with a red box. Other settings include High Grid Frequency Limit (50.5), Low Grid Frequency Limit (47.5), Set Eps On/Off (Off), Set Eps Frequency (50Hz), Set Eps Voltage (220V), AC Charging Power (20%), Charge Stopped Soc (100%), Ac Charge (Off), and AC Discharge Power (100%).

10.13) AC charging power: you can set the inverter's maximum output power

The screenshot shows the 'Setting' dialog box with the 'AC Charging Power' option selected and highlighted with a red box. The dropdown menu is open, showing 'Not Memory' as the selected option, also highlighted with a red box. Other settings include Set Eps Frequency (50Hz), Set Eps Voltage (220V), Set Save PF Command (Off), Charge Stopped Soc (100%), Ac Charge (On), AC Discharge Power (10%), Discharge Stopped Soc (10%), Set Reactive Power Ratio (1), Set Exportlimit (On), and SingleExport (Off).

10.14) Charge cutoff SOC: you can set the battery charge cutoff SOC (100 is recommended)

The screenshot shows the 'Setting' dialog box with the 'Charge Stopped Soc' option selected and highlighted with a red box. The value is set to 100%. Other settings include Set Eps Frequency (50Hz), Set Eps Voltage (220V), Set Save PF Command (Off), AC Charging Power (20%), Ac Charge (On), AC Discharge Power (10%), Discharge Stopped Soc (10%), Set Reactive Power Ratio (1), Set Exportlimit (On), and SingleExport (Off).

10.15) Enable AC charging:

The screenshot shows the 'Setting' dialog box with the 'Ac Charge' option selected and highlighted with a red box. The dropdown menu is open, showing 'On' as the selected option, also highlighted with a red box. Other settings include AC Charging Power (20%), Charge Stopped Soc (100%), AC Discharge Power (10%), Discharge Stopped Soc (10%), Set Reactive Power Ratio (1), Set Exportlimit (On), SingleExport (Off), Set PF Value (1.0), Charge Max Current (100.0), and Discharge Max Current (100.0).

10.16) AC discharge power: you can set the battery discharge power

The screenshot shows the 'Setting' menu with the following options and values:

- AC Charging Power: 20 %
- Charge Stopped Soc: 100 %
- Ac Charge: On
- AC Discharge Power: 10 %** (highlighted with a red box)
- Discharge Stopped Soc: 10 %
- Set Reactive Power Ratio: 1, PF Fixed 1, Not Memory
- Set Exportlimit: On, 0.0, Limit Power Rate(%)
- SingleExport: Off
- Set PF Value: 1.0, (-1~1)
- Charge Max Current: 1000, (0~200A)
- Discharge Max Current: 1000, (0~200A)

Buttons at the bottom: Please Enter Key To Save, Yes, Advanced Set, Cancel.

10.17) Discharge cutoff SOC: you can set the battery discharge cutoff SOC (10 is recommended)

The screenshot shows the 'Setting' menu with the following options and values:

- AC Charging Power: 20 %
- Charge Stopped Soc: 100 %
- Ac Charge: On
- AC Discharge Power: 10 %
- Discharge Stopped Soc: 10 %** (highlighted with a red box)
- Set Reactive Power Ratio: 1, PF Fixed 1, Not Memory
- Set Exportlimit: On, 0.0, Limit Power Rate(%)
- SingleExport: Off
- Set PF Value: 1.0, (-1~1)
- Charge Max Current: 100.0, (0~200A)
- Discharge Max Current: 100.0, (0~200A)

Buttons at the bottom: Please Enter Key To Save, Yes, Advanced Set, Cancel.

10.18) Set Reactive Power: you can set the corresponding PF mode and select whether to save the configured values

The screenshot shows the 'Setting' menu with the following options and values:

- AC Discharge Power: 10 %
- Discharge Stopped Soc: 10 %
- Set Reactive Power Ratio: 1, PF Fixed 1, Not Memory** (highlighted with a red box)
- Set Exportlimit: On
- SingleExport
- Set PF Value
- Charge Max Current
- Discharge Max Current
- Equalization Voltage: 900.0, (600~1000V)
- EOD Voltage: 600.0, (600~1000V)

The dropdown menu for 'Set Reactive Power Ratio' is open, showing options: PF Fixed 1, PF Fixed 1, Set PF, Default PF Line, (Cape)Reactive P Rate, (Ind)Reactive P Rate, Or Model, Positive and negative... The 'PF Fixed 1' option is selected.

Buttons at the bottom: Please Enter Key To Save, Yes, Advanced Set, Cancel.

10.19) Export Limitation: You can enable/disable the export limitation function according to the local applicable regulations and set the export limit power rate if it is enabled

The screenshot shows the 'Setting' menu with the following options and values:

- AC Discharge Power: 10 %
- Discharge Stopped Soc: 10 %
- Set Reactive Power Ratio: 1, PF Fixed 1, Not Memory
- Set Exportlimit: On, 0.0, Limit Power Rate(%)** (highlighted with a red box)
- SingleExport: Off
- Set PF Value: 1.0, (-1~1)
- Charge Max Current: 160.0, (0~200A)
- Discharge Max Current: 160.0, (0~200A)
- Equalization Voltage: 900.0, (600~1000V)
- EOD Voltage: 600.0, (600~1000V)

The dropdown menu for 'Set Exportlimit' is open, showing options: On, On, Off. The 'On' option is selected.

Buttons at the bottom: Please Enter Key To Save, Yes, Advanced Set, Cancel.

### 10.20) Single-phase Export Limitation

**Setting**

- AC Discharge Power 10 % Not Memory
- Discharge Stopped Soc 10 %
- Set Reactive Power Ratio 1 PF Fixed 1 Not Memory
- Set Exportlimit On 0.0 Limit Power Rate(%)
- SingleExport Off**
- Set PF Value On 1~1
- Charge Max Current Off 0~200A
- Discharge Max Current 160.0 (0~200A)
- Equalization Voltage 900.0 (600~1000V)
- EOD Voltage 600.0 (600~1000V)

Point 1 (Powerpercent,PFinepoint) 0 -1.0  
Point 2 (Powerpercent,PFinepoint) 0 1.0

Please Enter Key To Save Yes Advanced Set Cancel

### 10.22) Charge Max. Current: you can set the battery maximum charge current

**Setting**

- AC Discharge Power 10 % Not Memory
- Discharge Stopped Soc 10 %
- Set Reactive Power Ratio 1 PF Fixed 1 Not Memory
- Set Exportlimit On 0.0 Limit Power Rate(%)
- SingleExport Off
- Set PF Value 1.0 (-1~1)
- Charge Max Current 160.0 (0~200A)**
- Discharge Max Current 160.0 (0~200A)
- Equalization Voltage 900.0 (600~1000V)
- EOD Voltage 600.0 (600~1000V)

Point 1 (Powerpercent,PFinepoint) 0 -1.0  
Point 2 (Powerpercent,PFinepoint) 0 1.0

Please Enter Key To Save Yes Advanced Set Cancel

### 10.21) Set PF value: you can set the PF value, ranging from -1 to 1.

**Setting**

- AC Discharge Power 10 % Not Memory
- Discharge Stopped Soc 10 %
- Set Reactive Power Ratio 1 PF Fixed 1 Not Memory
- Set Exportlimit On 0.0 Limit Power Rate(%)
- SingleExport Off
- Set PF Value 1.0 (-1~1)**
- Charge Max Current 160.0 (0~200A)
- Discharge Max Current 160.0 (0~200A)
- Equalization Voltage 900.0 (600~1000V)
- EOD Voltage 600.0 (600~1000V)

Point 1 (Powerpercent,PFinepoint) 0 -1.0  
Point 2 (Powerpercent,PFinepoint) 0 1.0

Please Enter Key To Save Yes Advanced Set Cancel

### 10.23) Discharge Max. Current: you can set the battery maximum discharge current

**Setting**

- Set Exportlimit On 0.0 Limit Power Rate(%)
- SingleExport Off
- Set PF Value 1.0 (-1~1)
- Charge Max Current 160.0 (0~200A)
- Discharge Max Current 160.0 (0~200A)**
- Equalization Voltage 900.0 (600~1000V)
- EOD Voltage 600.0 (600~1000V)

Point 1 (Powerpercent,PFinepoint) 0 -1.0  
Point 2 (Powerpercent,PFinepoint) 0 1.0  
Point 3 (Powerpercent,PFinepoint) 0 -1.0  
Point 4 (Powerpercent,PFinepoint) 0 -1.0

Powerpercent (0~100): PFinepoint (1~1):

Please Enter Key To Save Yes Advanced Set Cancel

10.24) Equalization voltage: you can set the battery maximum charge voltage

**Setting** [X]

Set Exportlimit On 0.0 Limit Power Rate(%)

SingleExport Off

Set PF Value 1.0 (-1~1)

Charge Max Current 160.0 (0~200A)

Discharge Max Current 160.0 (0~200A)

Equalization Voltage 950.0 (600~1000V)

EOD Voltage 600.0 (600~1000V)

Custom PF Curve

Point 1 (Powerpercent, Pflinepoint) 0 -1.0

Point 2 (Powerpercent, Pflinepoint) 0 -1.0

Point 3 (Powerpercent, Pflinepoint) 0 -1.0

Point 4 (Powerpercent, Pflinepoint) 0 -1.0

Powerpercent (0~100); Pflinepoint (-1~1);

Please Enter Key To Save [Yes] [Advanced Set] [Cancel]

10.25) EOD voltage: you can set the battery discharge cutoff voltage

**Setting** [X]

Set Exportlimit On 0.0 Limit Power Rate(%)

SingleExport Off

Set PF Value 1.0 (-1~1)

Charge Max Current 160.0 (0~200A)

Discharge Max Current 160.0 (0~200A)

Equalization Voltage 950.0 (600~1000V)

EOD Voltage 600.0 (600~1000V)

Custom PF Curve

Point 1 (Powerpercent, Pflinepoint) 0 -1.0

Point 2 (Powerpercent, Pflinepoint) 0 -1.0

Point 3 (Powerpercent, Pflinepoint) 0 -1.0

Point 4 (Powerpercent, Pflinepoint) 0 -1.0

Powerpercent (0~100); Pflinepoint (-1~1);

Please Enter Key To Save [Yes] [Advanced Set] [Cancel]

10.26) Customized PF curve: you can set the power percentage and the power factor for each point of the PF curve

**Setting** [X]

Set Exportlimit On 0.0 Limit Power Rate(%)

SingleExport Off

Set PF Value 1.0 (-1~1)

Charge Max Current 160.0 (0~200A)

Discharge Max Current 160.0 (0~200A)

Equalization Voltage 950.0 (600~1000V)

EOD Voltage 600.0 (600~1000V)

Custom PF Curve

Point 1 (Powerpercent, Pflinepoint) 0 -1.0

Point 2 (Powerpercent, Pflinepoint) 0 -1.0

Point 3 (Powerpercent, Pflinepoint) 0 -1.0

Point 4 (Powerpercent, Pflinepoint) 0 1.0

Powerpercent (0~100); Pflinepoint (-1~1);

Please Enter Key To Save [Yes] [Advanced Set] [Cancel]

Meter

**Device**

Power: 15.2 kW, Voltage: 525 V, Current: 63 A

Energy: 954.9 kWh, Inverter: 3555221.5 Wh, Battery: 65 kWh, Inverter: 1121.3 kWh, Battery: 4266286 kWh

Device: Fronius Inverter

Device Serial Number: 21456 [Search]

1	Device: Fronius Inverter	Device Serial Number: 21456	Device Type: Inverter	Device Status: Online	Device Location: Home
---	--------------------------	-----------------------------	-----------------------	-----------------------	-----------------------

- 1) Enter the serial number of the meter or the datalogger to search for the desired meter
- 2) Meter type
- 3) The datalogger worked in conjunction with the meter
- 4) Status of the meter
- 5) The serial number of the WIT inverter to which the meter is connected

# 9 System Maintenance



## 9.1 Routine Maintenance

### 9.1.1 Clean the Chassis

 <b>DANGER</b>	<ul style="list-style-type: none"> <li>• Before performing any operation, disconnect the AC and DC power supply and wait for 5 minutes after the system is powered off.</li> <li>• Wipe the dust off the chassis and clean the chassis with a moistened cloth.</li> </ul>
--	---

- 1) Check periodically that the humidity is within the acceptable range and keep it away from dust;
- 2) Check the ventilation and heat dissipation of the equipment regularly. For details, see Section 9.1.2.

### 9.1.2 Fan Maintenance

 <b>DANGER</b>	<ul style="list-style-type: none"> <li>• Only qualified and trained electrical technicians are allowed to perform operations. Technicians must observe instructions in this manual local regulations.</li> <li>• Before performing any operation, disconnect all power supplies and wait for 5 minutes until the residual voltage is completely discharged.</li> </ul>
 <b>WARNING</b>	<ul style="list-style-type: none"> <li>• Do not use the air pump to clean the fan. Otherwise, the fan may be damaged.</li> </ul>

Ventilation and heat dissipation is essential to protect the WIT Inverter from performance de-rate due to excess heat. The fan in the WIT Inverter works to cool the components and the heat sink when the temperature is too high. Check the following possible causes and measures when an exception occurs:

- 1> The fan is stuck with foreign objects or there is dust accumulation on the heat sink; clean the fan cover, fan blades and the heat sink.
- 2> The fan is damaged and needs to be replaced.
- 3> The installation position of the WIT Inverter is not well-ventilated. Select an appropriate installation position that meets the basic installation requirements.

#### Cleaning and replacing the fan:

- 1> Before cleaning or replacing a fan, disconnect the DC and AC power supply and wait for at least 5 minutes.
- 2> Remove the fan fixing plate using a cross-head screwdriver, as shown in Fig 9.1:

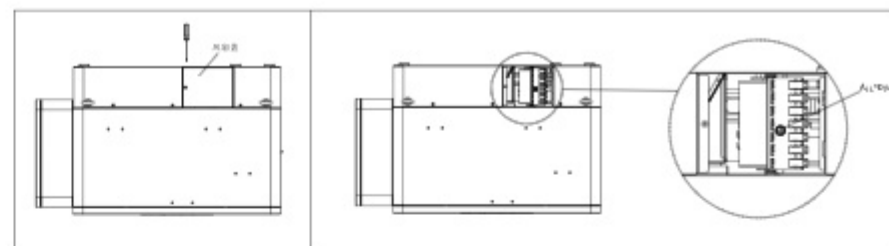

Fig 9.1 Position of the fan fixing plate

- 3> Disconnect the fan connector, remove the fan fixing plate with a screwdriver, and remove the fan, as shown in Fig 9.2:



Fig 9.2 Position of the fan

#### NOTE:

- ① WIT 50-100K-A, WIT 50-100K-H, WIT 50-100K-AE, WIT 50-100K-HE models have five external fans;
  - ② WIT 50-100K-AU and WIT 50-100K-HU models have seven external fans;
- 4> Clean the fan cover, fan blades, and the heat sink, or replace the fan.
    - (1) Use an air pump to clean the heat sink, and use a brush or wet cloth to clean the fan and the its cover;
    - (2) Remove the fan for cleaning if necessary;
    - (3) Remove the fan that needs to be replaced using a cross-head screwdriver and install a new fan.
    - (4) Bind the cables and fix them with a cable tie.
    - (5) Reinstall the fan, the fan fixing plate, and the WIT Inverter.



## 9.2 Troubleshooting

 <b>DANGER</b>	<ul style="list-style-type: none"> <li>It must be operated by trained and professional electrical technicians. Technicians must observe instructions in this manual and local regulations.</li> <li>If the WIT Inverter reports the “PV Isolation low” alarm, do not touch the equipment as a ground fault might have occurred.</li> <li>Beware of high voltages which can cause electric shocks.</li> </ul>
--	--

### 9.2.1 Warning

Warnings indicate abnormal situations of WIT 50-100K Storage/Hybrid Inverters, leading to a reduction in the output power. The warning sign will disappear once the fault is rectified by restarting the inverter or reconfiguring the system. The warning codes are shown in Table 9.1:

Table 9.1 Warning codes

Warning	Description	Suggestion
Warning 200	String fault	1. Check if the PV panels are normal after shutdown. 2. If the error message persists, contact Growatt support.
Warning 201	PV string/PID quick-connect terminals abnormal	1. Check the wiring of the string terminals after shutdown. 2. If the error message persists, contact Growatt support.
DC SPD Warning	DC SPD function abnormal	1. Check the DC SPD after shutdown. 2. If the error message persists, contact Growatt support.
Warning 203	PV1 or PV2 short circuited	1. Check if PV1 or PV2 is short circuited. 2. If the error message persists, contact Growatt support.
Boost Warning	PV Boost driver abnormal	1. Restart the inverter. 2. If the error message persists, contact Growatt support.
AC SPD Warning	AC SPD function abnormal	1. After shutdown, check the AC SPD. 2. If the fault persists, contact Growatt.
Warning 208	DC fuse blows	1. Power off the system and check the fuse. 2. If the fault persists, contact Growatt.

Warning	Description	Suggestion
Warning 209	DC input voltage exceeds the upper threshold	1. Turn off the DC switch immediately and check the DC voltage. 2. If the DC voltage is within the specified range and the error message persists, contact Growatt support.
PV Reversed	PV string is reversely connected	1. Check the polarity of the PV terminals. 2. If the error message persists, contact Growatt support.
Warning 219	PID function abnormal	1. Restart the inverter. 2. If the error message persists, contact Growatt support.
Warning 220	PV string disconnected	1. Check if the PV string is properly connected. 2. If the error message persists, contact Growatt support.
Warning 221	PV string current unbalanced	1. Check if the PV panels of the corresponding string are normal. 2. If the error message persists, contact Growatt support.
Warning 300	No utility grid connected or utility grid power failure	1. Check if the grid is down. 2. If the error message persists, contact Growatt support.
Warning 301	Grid voltage is beyond the permissible range	1. Check if the grid voltage is within the specified range. 2. If the error message persists, contact Growatt support.
Warning 302	Grid frequency is beyond the permissible range	1. Check if the grid frequency is within the specified range. 2. If the error message persists, contact Growatt support.
Warning 303	Overload	1. Please reduce the load connected to the EPS output terminal. 2. If the error message persists, contact Growatt support.
Warning 308	Meter disconnected	1. Check if the meter is properly connected. 2. If the error message persists, contact Growatt support.
Warning 309	Meter is reversely connected	1. Check if the L line and the N line of the meter are reversely connected. 2. If the error message persists, contact Growatt support.

Warning	Description	Suggestion
Warning 310	The voltage difference between the N line and the PE cable is abnormal	1. Check if the PE cable is reliably connected after shutdown. 2. If the error message persists, contact Growatt support.
Warning 311	Phase sequence error	No operation is required. The PCS will automatically adjust the phase sequence.
Warning 400	Fan failure	1. Check if the fan is properly connected after shutdown. 2. If the error message persists, contact Growatt support.
Warning 401	Meter abnormal	1. Check if the meter is turned on. 2. If the meter is correctly connected to the inverter.
Warning 402	Communication between the optimizer and the inverter is abnormal	1. Check if the optimizer is turned on. 2. If the optimizer is correctly connected to the inverter.
Warning 407	Over-temperature	1. Restart the inverter. 2. If the error message persists, contact Growatt support.
Warning 408	NTC temperature sensor is broken	1. Restart the inverter. 2. If the error message persists, contact Growatt support.
Warning 411	Sync signal abnormal	1. Check if the sync cable is abnormal. 2. If the error message persists, contact Growatt support.
Warning 412	Startup requirements of grid connection are not met	1. Check if the grid voltage is within the specified range and check if the grid-connection startup voltage configuration is correct. 2. Check if the PV voltage is within the specified range. 3. Restart the inverter. If the error message persists, contact Growatt support.
Warning 500	The inverter failed to communicate with the battery	1. Check if the battery is turned on. 2. Check if the battery is correctly and securely connected to the inverter.
Warning 501	Battery disconnected	1. Check if the battery is properly connected. 2. If the error message persists, contact Growatt support.

Warning	Description	Suggestion
Warning 502	Battery voltage too high	1. Check if the battery voltage is within the permissible range. 2. Check if the battery is correctly connected. 3. If the error message persists, contact Growatt support.
Warning 503	Battery voltage too low	1. Check if the battery voltage is within the permissible range. 2. Check if the battery is correctly connected. 3. If the error message persists, contact Growatt support.
Warning 504	Battery terminals are reversely connected	1. Check if the positive and negative terminals of the battery are reversely connected. 2. If the error message persists, contact Growatt support.
Warning 505	Temperature sensor of the lead-acid battery is disconnected	1. Check if the temperature sensor of the lead-acid battery is installed or not. 2. Check if the temperature sensor is well-connected. 3. If the error message persists, contact Growatt support.
Warning 506	Battery temperature is out of range	1. Check if the ambient temperature of the battery is within the specified range. 2. If the error message persists, contact Growatt support.
Warning 507	BMS reported a fault; both charging and discharging failed	1. Figure out the cause according to the BMS error code. 2. If the error message persists, contact Growatt support.
Warning 508	Lithium battery overload protection	1. Check if the power of the load exceeds the BAT rated discharge power. 2. If the error message persists, contact Growatt support.
Warning 509	BMS communication abnormal	1. Restart the inverter. 2. If the error message persists, contact Growatt support.
Warning 510	BAT SPD function abnormal	1. Check the BAT SPD after powering off the device. 2. If the error message persists, contact Growatt support.

Warning	Description	Suggestion
Warning 601	DC component over high in output voltage	1. Restart the inverter. 2. If the error message persists, contact Growatt support.
Warning 605	Off-grid bus voltage too low	1. Check if the load power exceeds the upper limit. 2. Restart the inverter. If the error message persists, contact Growatt support.
Warning 609	Balanced circuit abnormal	1. Restart the inverter. 2. If the error message persists, contact Growatt support.

### 9.2.2 Error

The error code indicates that the device is damaged or the configurations are abnormal. Only qualified and trained electrical technicians are allowed to rectify the faults. The error message will disappear after the fault is rectified. If the problem persists, please contact Growatt.

Table 9.2 Error codes

Error Code	Description	Suggestion
AFCI Fault	An arc fault has been detected	1. After shutdown, check the connection of the PV string. 2. Restart the inverter. 3. If the error message persists, please contact Growatt support.
GFCI High	An excessively high leakage current has been detected	1. Restart the inverter. 2. If the error message persists, please contact Growatt support.
PV Voltage High	DC input voltage exceeds the upper threshold	1. Disconnect the DC switch immediately and check the voltage. 2. If the DC input voltage is within the permissible range and the error message persists, please contact Growatt support.
PV Isolation Low	PV panels have low insulation resistance	1. Check if the PV strings are properly grounded. 2. If the error message persists, please contact Growatt support.
PV Reversed	PV string reversely connected	1. After shutdown, check if the PV string is reversely connected to the inverter. 2. Restart the inverter. 3. If the error message persists, please contact Growatt support.
AC V Outrange	Grid voltage is beyond the permissible range	1. Check the grid voltage. 2. If the grid voltage is within the permissible range and the error message persists, please contact Growatt support.
No AC	No utility grid connected or utility grid power failure	1. After shutdown, check the AC wiring. 2. If the error message persists, please contact Growatt support.
NE Abnormal	The voltage difference between the N line and the PE cable is abnormal	1. After shutdown, check if the ground cable is reliably connected. 2. If the error message persists, please contact Growatt support.

Error Code	Description	Suggestion
AC F Outrange	Grid frequency is beyond the permissible range	1. Check the grid frequency and restart the inverter. 2. If the error message persists, please contact Growatt support..
Error 309	Grid ROCOF (Rated of Change of Frequency) abnormal	1. Check the grid frequency and restart the inverter. 2. If the error message persists, please contact Growatt support.
NE Fault	Neutral-to-Ground voltage is too low	1. Check whether the N line on the inverter side with PV negative grounding is short-circuited with the ground cable and whether the output side is isolated with a transformer. 2. If the error message persists, please contact Growatt support.
Error 311	Export limitation fail-safe	1. After shutdown, check the connection of the CT and the meter. 2. If the error message persists, please contact Growatt support.
Error 400	DCI bias abnormal	1. Restart the inverter. 2. If the error message persists, contact Growatt support.
Error 402	High DC component in output current	1. Restart the inverter. 2. If the error message persists, contact Growatt support.
Error 404	Bus voltage sampling abnormal	1. Restart the inverter. 2. If the error message persists, please contact Growatt support.
Error 405	Relay fault	1. Restart the inverter. 2. If the error message persists, please contact Growatt support.
Error 408	Over-temperature	1. After shutdown, check the temperature of the inverter and restart the inverter after the temperature is within the acceptable range. 2. If the error message persists, please contact Growatt support.
Error 409	Bus voltage abnormal	1. Restart the inverter. 2. If the error message persists, please contact Growatt support.
Error 411	Internal communication failure	1. Check the wiring of the communication board after shutdown. 2. If the error message persists, please contact Growatt support.

Error Code	Description	Suggestion
Error 412	Temperature sensor disconnected	1. Check if the temperature sensor module is properly connected. 2. If the error message persists, please contact Growatt support.
Error 413	IGBT drive fault	1. Restart the inverter. 2. If the error message persists, please contact Growatt support.
Error 414	EEPROM error	1. Restart the inverter. 2. If the error message persists, please contact Growatt support.
Error 415	Auxiliary power supply abnormal	1. Restart the inverter. 2. If the error message persists, please contact Growatt support.
Error 416	DC/AC overcurrent protection	1. Restart the inverter. 2. If the error message persists, please contact Growatt support.
Error 417	Communication protocol mismatch	1. Restart the inverter. 2. If the error message persists, please contact Growatt support.
Error 418	DSP and COM firmware version mismatch	1. Check the firmware version. 2. If the error message persists, please contact Growatt support.
Error 419	DSP software and hardware version mismatch	1. Check the firmware version. 2. If the error message persists, please contact Growatt support.
Error 421	CPLD abnormal	1. Restart the inverter. 2. If the error message persists, please contact Growatt support.
Error 422	Redundancy sampling inconsistent	1. Restart the inverter. 2. If the error message persists, please contact Growatt support.
Error 423	PWM pass-through signal failure	1. Restart the inverter. 2. If the error message persists, please contact Growatt support.
Error 425	AFCI self-test failure	1. Restart the inverter. 2. If the error message persists, please contact Growatt support.
Error 426	PV current sampling abnormal	1. Restart the inverter. 2. If the error message persists, please contact Growatt support.

Error Code	Description	Suggestion
Error 427	AC current sampling abnormal	1. Restart the inverter. 2. If the error message persists, please contact Growatt support.
Error 430	EPO fault	1. Restart the inverter. 2. If the error message persists, please contact Growatt support.
Error 431	Monitoring chip BOOT verification failed	1. Restart the inverter. 2. If the error message persists, please contact Growatt support.
Error 500	BMS failed to communicate with the inverter	1. Check the connection of the RS485 cable between the inverter and the battery. 2. Check if the battery is in the sleep mode. 3. If the error message persists, please contact Growatt support.
Error 501	The BMS reports that the battery failed to charge/discharge	1. Check the connection of the RS485 cable between the inverter and the battery. 2. Check if the battery is in the sleep mode. 3. If the error message persists, please contact Growatt support.
Bat Voltage Low	The battery voltage is below the lower threshold	1. Check the battery voltage. 2. If the error message persists, please contact Growatt support.
Error 503	The battery voltage exceeds upper threshold	1. Check the battery voltage. If it is within the permissible range, please restart the inverter. If not, please replace the battery. 2. If the error message persists, please contact Growatt support.
Error 504	The battery temperature is beyond the range for charging/discharging	1. Check the temperature of the battery. 2. If the error message persists, please contact Growatt support.
Bat Reversed	Battery terminals reversed	1. Check if the battery terminals are reversely connected. 2. If the error message persists, please contact Growatt support.
Error 506	Battery open-circuited	1. Check the wiring of the battery terminals. 2. If the error message persists, please contact Growatt support.

Error Code	Description	Suggestion
Error 507	Battery overload protection	1. Check if the power of the load exceeds the battery rated discharge power. 2. If the error message persists, please contact Growatt support.
Error 508	BUS2 Volt Abnormal	1. Restart the inverter. 2. If the error message persists, please contact Growatt support.
Error 509	BAT Charge OCP (Overcurrent Protection)	1. Check if the PV voltage is oversized. 2. If the error message persists, please contact Growatt support.
Error 510	BAT Discharge OCP (Overcurrent Protection)	1. Check if the battery discharge current configuration is proper. 2. If the error message persists, please contact Growatt support.
Error 511	BAT soft start failed	1. Restart the inverter. 2. If the error message persists, please contact Growatt support.
EPS Output Short	Off-grid output short-circuited	1. Restart the inverter. 2. If the error message persists, please contact Growatt support.
Error 601	Off-grid BUS Volt Low	1. Check if the battery is working properly or the battery experiences capacity loss. 2. If the error message persists, please contact Growatt support.
Error 602	Abnormal Volt at the off-grid terminal	1. Check if a voltage is present at the AC port. 2. If the error message persists, please contact Growatt support.
Error 603	Soft start failed	1. Restart the inverter. 2. If the error message persists, please contact Growatt support.
Error 604	Off-grid output voltage abnormal	1. Restart the inverter. 2. If the error message persists, please contact Growatt support.
Error 605	Balanced circuit self-test failed	1. Restart the inverter. 2. If the error message persists, please contact Growatt support.

# Product Specifications 10

Error Code	Description	Suggestion
Error 606	High DC component in output voltage	1. Restart the inverter. 2. If the error message persists, please contact Growatt support.
EPS Overload	Off-grid output overload	1. Restart the inverter. 2. If the error message persists, please contact Growatt support.
Error 608	Off-grid parallel signal abnormal	1. Check if the communication cables are properly connected. 2. If the error message persists, please contact Growatt support.

Table 10.1 WIT 50/63/75/100K-A Specification

Model	WIT 50K-A	WIT 63K-A	WIT 75K-A	WIT100K-A
<b>Specifications</b>				
Battery data(DC)				
Continuous charging / discharging power	56700W	71400W	85100W	113500W
Battery voltage range	600-1000V (for 3P3W) / 680-1000V (for 3P4W)			
Recommended battery voltage	768V			
Max. charging and discharging current	83.3A	105A	125A	167A
BMS communication	RS485/CAN			
Output data(AC)				
Rated AC output power	50000W	63000W	75000W	100000W
Max. AC apparent power	55000VA	69300VA	82500VA	110000VA
Nominal AC voltage	220V/230V/240V (L-N) 380V/400V/415V (L-L)			
AC voltage range	-15% ~ +10%			
AC grid frequency	50/60 Hz			
AC grid frequency range	45-55Hz/55-65 Hz			
Rated output current	75.6A@220V 72.5A@230V	95.5A@220V 91.3A@230V	113.6A@220V 108.7A@230V	151.5A@220V 144.9A@230V
Max. output current	83.3A@220V 79.7A@230V	105A@220V 100.4A@230V	125A@220V 119.6A@230V	166.7A@220V 159.4A@230V
Power factor (@nominal power)	>0.99			
Adjustable power factor	(1 leading ~ 1 lagging)			
THDi	<3%			
AC grid connection type	3P+PE/3P+N+PE			
Backup power(AC)				
Rated AC output power	50000W	63000W	75000W	100000W
Max. AC apparent power	60000VA	75600VA	90000VA	120000VA
Rated AC output voltage	220V/230V/240V (L-N) 380V/400V/415V (L-L)			
Nominal AC output frequency	50/60 Hz			
Max. output current	90.9A@220V 87A@230V	114.5A@220V 109.6A@230V	136.4A@220V 130.4A@230V	181.8A@220V 173.9A@230V

Model	WIT 50K-A	WIT 63K-A	WIT 75K-A	WIT100K-A
<b>Specifications</b>				
Voltage accuracy	1%			
Frequency accuracy	0.1Hz			
THDv	3%			
Unbalanced load	100% three-phase unbalanced			
Overload capacity	≤110%, continuous; 110% ~ 120%:10min >120%, 200ms			
<b>Efficiency</b>				
Max. battery charge/ discharge efficiency	98.20%	98.20%	98.20%	98.20%
<b>Protection devices</b>				
PV reverse polarity protection	Yes			
DC surge protection	Yes (Type II)			
Insulation resistance monitoring	Yes			
RCD detection	Yes			
AC short-circuit protection	Yes			
AC surge protection	Yes (Type II)			
Ground fault monitoring	Yes			
Grid monitoring	Yes			
<b>Display and communication</b>				
Display	OLED+LED/APP			
USB	Yes			
RS485	Yes			
4G	Optional			
WIFI	Optional			
<b>General data</b>				
Dimensions (W /H / D) in mm	820*1350*510mm			
Weight	120kg			
Operating temperature range	-30°C ... +60°C (> 50°C, derating)			
Noise emission (typical)	≤53dB(A)	≤53dB(A)	≤65dB(A)	≤65dB(A)

Model	WIT 50K-A	WIT 63K-A	WIT 75K-A	WIT100K-A
<b>Specifications</b>				
Relative humidity	0~100%			
Altitude	4000m			
Nighttime power consumption	20W			
Standby power consumption	250W			
Topology	Transformerless			
Cooling	Smart air cooling			
Protection degree	IP66			
Warranty	5/10 years(Optional)			
<b>Standard compliance</b>				
Safety	IEC/EN 62109-1,IEC/EN 62109-2,IEC/EN62477-1			
EMC	EN 62920-2017			
Grid connection standards	EN50549-1, NRS 097-2-1,G99:2020,UKCA,VDE 4105,VDE4110,CEI 0-21:2019+V1:2020,CEI 0- 16:2019+V1:2020,TOR Type A,VDE 0126,NC RFG,PSE- 2018,PTPIREE-2021,C 10/C 11:2021,UNE 217001-2020,UNE 217002-2020,RD647:2020,NTS Type B			

Table 10.2 WIT 50/63/75/100K-H Specification

Model	WIT 50K-H	WIT 63K-H	WIT 75K-H	WIT100K-H
<b>Specifications</b>				
<b>Input data (DC)</b>				
Max. recommended PV power (for module STC)	109200W	124800W	156000W	156000W
Max. input voltage	1100V			
Start voltage	195V			
Nominal voltage	550V			
MPP voltage range	180V-800V			
Full power MPPT voltage range	520V-800V			
Max. input current per MPP tracker	32A			
Max. short-circuit current per MPP tracker	40A			
No. of MPP trackers	7	8	10	10
No. of PV strings per MPP tracker	2			
<b>Battery data (DC)</b>				
Continuous charging / discharging power	56700W	71400W	85100W	113500W
Battery voltage range	600-1000V (for 3P3W) / 680-1000V (for 3P4W)			
Recommended battery voltage	768V			
Max. charging and discharging current	83.3A	105A	125A	167A
BMS communication	RS485/CAN			
<b>Output data (AC)</b>				
Rated AC output power	50000W	63000W	75000W	100000W
Max. AC apparent power	55000VA	69300VA	82500VA	110000VA
Nominal AC voltage	220V/230V/240V (L-N) 380V/400V/415V (L-L)			
AC voltage range	-15% ~ +10%			
AC grid frequency	50/60 Hz			
AC grid frequency range	45~55Hz/55-65 Hz			
Rated output current	75.6A@220V 72.5A@230V	95.5A@220V 91.3A@230V	113.6A@220V 108.7A@230V	151.5A@220V 144.9A@230V
Max. output current	83.3A@220V 79.7A@230V	105A@220V 100.4A@230V	125A@220V 119.6A@230V	166.7A@220V 159.4A@230V

Model	WIT 50K-H	WIT 63K-H	WIT 75K-H	WIT100K-H
<b>Specifications</b>				
Power factor (@nominal power)	>0.99			
Adjustable power factor	(1 leading ~ 1 lagging)			
THDi	<3%			
AC grid connection type	3P+PE/3P+N+PE			
<b>Backup power (AC)</b>				
Rated AC output power	50000W	63000W	75000W	100000W
Max. AC apparent power	60000VA	75600VA	90000VA	120000VA
Rated AC output voltage	220V/230V/240V (L-N) 380V/400V/415V (L-L)			
Nominal AC output frequency	50/60 Hz			
Max. output current	90.9A@220V 87A@230V	114.5A@220V 109.6A@230V	136.4A@220V 130.4A@230V	181.8A@220V 173.9A@230V
Voltage accuracy	1%			
Frequency accuracy	0.1Hz			
THDv	3%			
Unbalanced load	100% three-phase unbalanced			
Overload capacity	≤110%, continuous; 110% ~ 120%:10min >120%, 200ms			
<b>Efficiency</b>				
Max. efficiency	98.00%	98.00%	98.00%	98.00%
Max. battery charge/ discharge efficiency	98.20%	98.20%	98.20%	98.20%
MPPT efficiency	99.90%	99.90%	99.90%	99.90%
<b>Protection devices</b>				
PV reverse polarity protection	Yes			
PV input DC switch	Yes			
DC surge protection	Yes(Type II)			
Insulation resistance monitoring	Yes			
RCD detection	Yes			



Model	WIT 50K-H	WIT 63K-H	WIT 75K-H	WIT100K-H
<b>Specifications</b>				
AC short-circuit protection	Yes			
AC surge protection	Yes(Type II)			
Ground fault monitoring	Yes			
Grid monitoring	Yes			
String monitoring	Yes			
Anti-PID function	Optional			
AFCI protection	Optional			
<b>Display and communication</b>				
Display	OLED+LED/APP			
USB	Yes			
RS485	Yes			
4G	Optional			
WIFI	Optional			
<b>General data</b>				
Dimensions (W / H / D) in mm	820*1350*510mm			
Weight	133kg	133kg	140kg	140kg
Operating temperature range	-30°C ... +60°C (> 50°C derating)			
Noise emission (typical)	≤53dB(A)	≤53dB(A)	≤65dB(A)	≤65dB(A)
Relative humidity	0~100%			
Altitude	4000m			
Nighttime power consumption	20W			
Standby power consumption	250W			
Topology	Transformerless			
Cooling	Smart air cooling			
Protection degree	IP66			
Warranty	5/10 years(Optional)			
<b>Standard compliance</b>				
Safety	IEC/EN 62109-1, IEC/EN 62109-2, IEC/EN62477-1			

Model	WIT 50K-H	WIT 63K-H	WIT 75K-H	WIT100K-H
<b>Specifications</b>				
EMC	EN 62920-2017			
Grid connection standards	EN50549-1, NRS 097-2-1, G99:2020, UKCA, VDE 4105, VDE4110, CEI 0-21:2019+V1:2020, CEI 0-16:2019+V1:2020, TOR Type A, VDE 0126, NC RFG, PSE-2018, PTPIREE-2021, C10/C11:2021, UNE 217001-2020, UNE 217002-2020, RD647:2020, NTS Type B			

Table 10.3 WIT 50/63/75/100K-AE Specification

Model	WIT 50K-AE	WIT 63K-AE	WIT 75K-AE	WIT100K-AE
<b>Specifications</b>				
<b>Battery data (DC)</b>				
Continuous charging / discharging power	56700W	71400W	85100W	113500W
Battery voltage range	600-1000V (for 3P3W) / 680-1000V (for 3P4W)			
Recommended battery voltage	768V			
Max. charging and discharging current	83.3A	105A	125A	167A
BMS communication	RS485/CAN			
<b>Ac grid-connection parameters</b>				
Rated AC output power	100000W/ 50000W	126000W/ 63000W	150000W/ 75000W	200000W/ 100000W
Max. AC apparent power	100000VA/ 55000VA	126000VA/ 69300VA	150000VA/ 82500VA	200000VA/ 110000VA
Nominal AC voltage	220V/230V/240V (L-N) 380V/400V/415V (L-L)			
AC voltage range	-15% ~ +10%			
AC grid frequency	50/60 Hz			
AC grid frequency range	45~55Hz/55-65 Hz			
Rated output current	151.5A/75.6A @220V 144.9A/72.5A @230V	190.9A/95.5A @220V 182.6A/91.3A @230V	227.3A/113.6A @220V 217.4A/108.7A @230V	303A/151.5A @220V 289.9A/144.9A @230V
Max. output current	151.5A/83.3A @220V 144.9A/79.7A @230V	190.9A/105A @220V 182.6A/100.4A @230V	227.3A/125A @220V 217.4A/119.6A @230V	303A/166.7A @220V 289.9A/159.4A @230V
Power factor (@nominal power)	>0.99			
Adjustable power factor	(1 leading ~ 1 lagging)			
THDi	<3%			
AC grid connection type	3P+PE/3P+N+PE			
<b>Backup power (AC)</b>				
Rated AC output power	50000W	63000W	75000W	100000W
Max. AC apparent power	60000VA	75600VA	90000VA	120000VA
Rated AC output voltage	220V/230V/240V (L-N) 380V/400V/415V (L-L)			

Model	WIT 50K-AE	WIT 63K-AE	WIT 75K-AE	WIT100K-AE
<b>Specifications</b>				
Rated AC output frequency	50/60 Hz			
Max. output current	90.9A@220V 87A@230V	114.5A@220V 109.6A@230V	136.4A@220V 130.4A@230V	181.8A@220V 173.9A@230V
Voltage accuracy	1%			
Frequency accuracy	0.1Hz			
THDv	3%			
Unbalanced load	100% three-phase unbalanced			
Overload capability	≤110%, continuous; 110% ~ 120%:10min >120%, 200ms			
Grid to off-grid switching time	< 200ms			
Switching time from off-grid to on-grid	0ms			
<b>Efficiency</b>				
Max. battery charge/discharge efficiency	98.20%	98.20%	98.20%	98.20%
<b>Protection devices</b>				
PV reverse polarity protection	Yes			
DC surge protection	Yes (Type II)			
Insulation resistance monitoring	Yes			
RCD detection	Yes			
AC short-circuit protection	Yes			
AC surge protection	Yes (Type II)			
Ground fault monitoring	Yes			
Grid monitoring	Yes			
<b>Display and communication</b>				
Display	OLED+LED/APP			
USB	Yes			
RS485	Yes			
4G	Optional			
WIFI	Optional			

Model	WIT 50K-AE	WIT 63K-AE	WIT 75K-AE	WIT100K-AE
<b>Specifications</b>				
General data				
Dimensions (W/H/D) in mm	820*1350*510mm			
Weight	130kg			
Operating temperature range	-30°C ... +60°C (> 50°C, derating)			
Noise emission (typical)	≤53dB(A)	≤53dB(A)	≤65dB(A)	≤65dB(A)
Relative humidity	0~100%			
Altitude	4000m			
Nighttime power consumption	20W			
Standby power consumption	250W			
Topology	Transformerless			
Cooling	Smart air cooling			
Protection degree	IP66			
Warranty	5/10 years(Optional)			
Certificates and approvals				
Safety	IEC/EN 62109-1, IEC/EN 62109-2, IEC/EN62477-1			
EMC	EN 62920-2017			
Grid connection standards	EN50549-1, NRS 097-2-1, G99:2020, UKCA, VDE 4105, VDE4110, CEI 0-21:2019+V1:2020, CEI 0-16:2019+V1:2020, TOR Type A, VDE 0126, NC RFG, PSE-2018, PTPIREE-2021, C10/C11:2021, UNE 217001-2020, UNE 217002-2020, RD647:2020, NTS Type B			

Table 10.4 WIT 50/63/75/100K-HE Specification

Model	WIT 50K-HE	WIT 63K-HE	WIT 75K-HE	WIT100K-HE
<b>Specifications</b>				
Input data (DC)				
Max. recommended PV power (for module STC)	109200W	124800W	156000W	156000W
Max. input voltage	1100V			
Start voltage	195V			
Nominal voltage	550V			
MPP voltage range	180V-800V			
Full power MPPT voltage range	520V-800V			
Max. input current per MPP tracker	32A			
Max. short-circuit current per MPP tracker	40A			
No. of MPP trackers	7	8	10	10
No. of PV strings per MPP tracker	2			
Battery data (DC)				
Continuous charging / discharging power	56700W	71400W	85100W	113500W
Battery voltage range	600-1000V (for 3P3W) / 680-1000V (for 3P4W)			
Recommended battery voltage	768V			
Max. charging and discharging current	83.3A	105A	125A	167A
BMS communication	RS485/CAN			
Output data (AC)				
Rated AC output power	100000W/ 50000W	126000W/ 63000W	150000W/ 75000W	200000W/ 100000W
Max. AC apparent power	100000VA/ 55000VA	126000VA/ 69300VA	150000VA/ 82500VA	200000VA/ 110000VA
Nominal AC voltage	220V/230V/240V (L-N) 380V/400V/415V (L-L)			
AC voltage range	-15% ~ +10%			
AC grid frequency	50/60 Hz			
AC grid frequency range	45~55Hz/55-65 Hz			

Model	WIT 50K-HE	WIT 63K-HE	WIT 75K-HE	WIT100K-HE
<b>Specifications</b>				
Rated output current	151.5A/75.6A @220V 144.9A/72.5A @230V	190.9A/95.5A @220V 182.6A/91.3A @230V	227.3A/113.6A @220V 217.4A/108.7A @230V	303A/151.5A @220V 289.9A/144.9A @230V
Max. output current	151.5A/83.3A @220V 144.9A/79.7A @230V	190.9A/105A @220V 182.6A/100.4A @230V	227.3A/125A @220V 217.4A/119.6A @230V	303A/166.7A @220V 289.9A/159.4A @230V
Power factor (@nominal power)	>0.99			
Adjustable power factor	(1 leading ~ 1 lagging)			
THDi	<3%			
AC grid connection type	3P+PE/3P+N+PE			
<b>Backup power (AC)</b>				
Rated AC output power	50000W	63000W	75000W	100000W
Max. AC apparent power	60000VA	75600VA	90000VA	120000VA
Rated AC output voltage	220V/230V/240V (L-N) 380V/400V/415V (L-L)			
Nominal AC output frequency	50/60 Hz			
Max. output current	90.9A@220V 87A@230V	114.5A@220V 109.6A@230V	136.4A@220V 130.4A@230V	181.8A@220V 173.9A@230V
Voltage accuracy	1%			
Frequency accuracy	0.1Hz			
THDv	3%			
Unbalanced load	100% three-phase unbalanced			
Overload capacity	≤110%, continuous; 110% ~ 120%:10min >120%, 200ms			
Switching time from on-grid to off-grid	< 200ms			
Switching time from off-grid to on- grid	0ms			
<b>Efficiency</b>				
Max. efficiency	98.00%	98.00%	98.00%	98.00%
Max. battery charge/discharge efficiency	98.20%	98.20%	98.20%	98.20%

Model	WIT 50K-HE	WIT 63K-HE	WIT 75K-HE	WIT100K-HE
<b>Specifications</b>				
MPPT efficiency	99.90%	99.90%	99.90%	99.90%
<b>Protection devices</b>				
PV reverse polarity protection	Yes			
PV input DC switch	Yes			
DC surge protection	Yes (Type II)			
Insulation resistance monitoring	Yes			
RCD detection	Yes			
AC short-circuit protection	Yes			
AC surge protection	Yes (Type II)			
Ground fault monitoring	Yes			
Grid monitoring	Yes			
String monitoring	Yes			
Anti-PID function	Optional			
AFCl protection	Optional			
<b>Display and communication</b>				
Display	OLED+LED/WIFI+APP			
USB	Yes			
RS485	Yes			
4G	Optional			
WIFI	Optional			
<b>General data</b>				
Dimensions (W / H / D) in mm	820*1350*510mm			
Weight	143kg	143kg	150kg	150kg
Operating temperature range	-30°C ... +60°C (> 50°C derating)			
Noise emission (typical)	≤53dB(A)	≤53dB(A)	≤65dB(A)	≤65dB(A)
Relative humidity	0-100%			
Altitude	4000m			

Model	WIT 50K-HE	WIT 63K-HE	WIT 75K-HE	WIT100K-HE
Nighttime power consumption	20W			
Standby power consumption	250W			
Topology	Transformerless			
Cooling	Smart air cooling			
Protection degree	IP66			
Warranty	5/10 years(Optional)			
Standard compliance				
Safety	IEC/EN 62109-1, IEC/EN 62109-2, IEC/EN62477-1			
EMC	EN 62920-2017			
Grid connection standards	EN50549-1, NRS 097-2-1, G99:2020, UKCA, VDE 4105, VDE4110, CEI 0-21:2019+V1:2020, CEI 0-16:2019+V1:2020, TOR Type A, VDE 0126, NC RFG, PSE-2018, PTPIREE-2021, C10/C11:2021, UNE 217001-2020, UNE 217002-2020, RD647:2020, NTS Type B			

Table 10.5 WIT 50/63/75/100K-AU Specification

Model	WIT 50K-AU	WIT 63K-AU	WIT 75K-AU	WIT100K-AU
Specifications				
Battery data (DC)				
Continuous charging / discharging power	56700W	71400W	85100W	113500W
Battery voltage range	600-1000V (for 3P3W) / 680-1000V (for 3P4W)			
Recommended battery voltage	768V			
Max. charging and discharging current	83.3A	105A	125A	167A
BMS communication	RS485/CAN			
Output data (AC)				
Rated AC output power	100000W/ 50000W	126000W/ 63000W	150000W/ 75000W	200000W/ 100000W
Max. AC apparent power	100000VA/ 55000VA	126000VA/ 69300VA	150000VA/ 82500VA	200000VA/ 110000VA
Nominal AC voltage	220V/230V/240V (L-N) 380V/400V/415V (L-L)			
AC voltage range	-15% ~ +10%			
AC grid frequency	50/60 Hz			
AC grid frequency range	45~55Hz/55-65 Hz			
Rated output current	151.5A/75.6A @220V 144.9A/72.5A @230V	190.9A/95.5A @220V 182.6A/91.3A @230V	227.3A/113.6A @220V 217.4A/108.7A @230V	303A/151.5A @220V 289.9A/144.9A @230V
Max. output current	151.5A/83.3A @220V 144.9A/79.7A @230V	190.9A/105A @220V 182.6A/100.4A @230V	227.3A/125A @220V 217.4A/119.6A @230V	303A/166.7A @220V 289.9A/159.4A @230V
Power factor(@nominal power)	>0.99			
Adjustable power factor	(1 leading ~ 1 lagging)			
THDi	<3%			
AC grid connection type	3P+PE/3P+N+PE			
Backup power (AC)				
Rated power	50000W	63000W	75000W	100000W
Max. apparent power	60000VA	75600VA	90000VA	120000VA
Rated AC output voltage	220V/230V/240V (L-N) 380V/400V/415V (L-L)			

Model	WIT 50K-AU	WIT 63K-AU	WIT 75K-AU	WIT100K-AU
<b>Specifications</b>				
Nominal AC output frequency	50/60 Hz			
Max. output current	90.9A@220V 87A@230V	114.5A@220V 109.6A@230V	136.4A@220V 130.4A@230V	181.8A@220V 173.9A@230V
Voltage accuracy	1%			
Frequency accuracy	0.1Hz			
THDv	3%			
Unbalanced load	100% three-phase unbalanced			
Overload capacity	≤110%, continuous; 110% ~ 120%:10min >120%, 200ms			
Switching time from on-grid to off-grid	< 20ms			
Switching time from off-grid to on-grid	0ms			
<b>Efficiency</b>				
Max. battery charge/discharge efficiency	98.20%	98.20%	98.20%	98.20%
<b>Protection devices</b>				
PV reverse polarity protection	Yes			
DC surge protection	Yes (Type II)			
Insulation resistance monitoring	Yes			
RCD detection	Yes			
AC short-circuit protection	Yes			
AC surge protection	Yes (Type II)			
Ground fault monitoring	Yes			
Grid monitoring	Yes			
<b>Display and communication</b>				
Display	OLED+LED/APP			
USB	Yes			
RS485	Yes			
4G	Optional			

Model	WIT 50K-AU	WIT 63K-AU	WIT 75K-AU	WIT100K-AU
<b>Specifications</b>				
WiFi	Optional			
<b>General data</b>				
Dimensions (W/H/D) in mm	820*1350*510mm			
Weight	140kg			
Operating temperature range	-30°C ... +60°C (> 50°C, derating)			
Noise emission (typical)	≤78dB(A)	≤78dB(A)	≤78dB(A)	≤78dB(A)
Relative humidity	0-100%			
Altitude	4000m			
Nighttime power consumption	20W			
Standby power consumption	250W			
Topology	Transformerless			
Cooling	Smart air cooling			
Protection degree	IP66			
Warranty	5/10 years(Optional)			
<b>Standard compliance</b>				
Safety	IEC/EN 62109-1, IEC/EN 62109-2, IEC/EN62477-1			
EMC	EN 62920-2017			
Grid connection standards	EN50549-1, NRS 097-2-1, G99:2020, UKCA, VDE 4105, VDE4110, CEI 0-21:2019+V1:2020, CEI 0-16:2019+V1:2020, TOR Type A, VDE 0126, NC RFG, PSE-2018, PTPIREE-2021, C10/C11:2021, UNE 217001-2020, UNE 217002-2020, RD647:2020, NTS Type B			

Table 10.6 WIT 50/63/75/100K-HU Specification

Model	WIT 50K-HU	WIT 63K-HU	WIT 75K-HU	WIT100K-HU
<b>Input data (DC)</b>				
Max. recommended PV power (for module STC)	109200W	124800W	156000W	156000W
Max. input voltage	1100V			
Start voltage	195V			
Nominal voltage	550V			
MPP voltage range	180V-800V			
Full power MPPT voltage range	520V-800V			
Max. input current per MPP tracker	32A			
Max. short-circuit current per MPP tracker	40A			
No. of MPP trackers	7	8	10	10
No. of PV strings per MPP tracker	2			
<b>Battery data (DC)</b>				
Continuous charging / discharging power	56700W	71400W	85100W	113500W
Battery voltage range	600-1000V (for 3P3W) / 680-1000V (for 3P4W)			
Recommended battery voltage	768V			
Max. charging and discharging current	83.3A	105A	125A	167A
BMS communication	RS485/CAN			
<b>Output data (AC)</b>				
Rated AC output power	100000W/ 50000W	126000W/ 63000W	150000W/ 75000W	200000W/ 100000W
Max. AC apparent power	100000VA/ 55000VA	126000VA/ 69300VA	150000VA/ 82500VA	200000VA/ 110000VA
Nominal AC voltage	220V/230V/240V (L-N) 380V/400V/415V (L-L)			
AC voltage range	-15% ~ +10%			
AC grid frequency	50/60 Hz			
AC grid frequency range	45~55Hz/55-65 Hz			

Model	WIT 50K-HU	WIT 63K-HU	WIT 75K-HU	WIT100K-HU
<b>Specifications</b>				
Rated output current	151.5A/75.6A @220V 144.9A/72.5A @230V	190.9A/95.5A @220V 182.6A/91.3A @230V	227.3A/113.6A @220V 217.4A/108.7A @230V	303A/151.5A @220V 289.9A/144.9A @230V
Max. output current	151.5A/83.3A @220V 144.9A/79.7A @230V	190.9A/105A @220V 182.6A/100.4A @230V	227.3A/125A @220V 217.4A/119.6A @230V	303A/166.7A @220V 289.9A/159.4A @230V
Power factor (@nominal power)	>0.99			
Adjustable power factor	(1 leading ~ 1 lagging)			
THDi	<3%			
AC grid connection type	3P+PE/3P+N+PE			
<b>Backup power (AC)</b>				
Rated AC output power	50000W	63000W	75000W	100000W
Max. AC apparent power	60000VA	75600VA	90000VA	120000VA
Rated AC output voltage	220V/230V/240V (L-N) 380V/400V/415V (L-L)			
Nominal AC output frequency	50/60 Hz			
Max. output current	90.9A@220V 87A@230V	114.5A@220V 109.6A@230V	136.4A@220V 130.4A@230V	181.8A@220V 173.9A@230V
Voltage accuracy	1%			
Frequency accuracy	0.1Hz			
THDv	3%			
Unbalanced load	100% three-phase unbalanced			
Overload capacity	≤110%, continuous; 110% ~ 120%:10min >120%, 200ms			
Switching time from on-grid to off-grid	< 20ms			
Switching time from off-grid to on-grid	0ms			
<b>Efficiency</b>				
Max. efficiency	98.00%	98.00%	98.00%	98.00%
Max. battery charge/discharge efficiency	98.20%	98.20%	98.20%	98.20%

Model	WIT 50K-HU	WIT 63K-HU	WIT 75K-HU	WIT100K-HU
<b>Specifications</b>				
MPPT efficiency	99.90%	99.90%	99.90%	99.90%
<b>Protection devices</b>				
PV reverse protection	Yes			
PV input DC switch	Yes			
DC surge protection	Yes(Type II)			
Insulation resistance monitoring	Yes			
RCD detection	Yes			
AC short-circuit protection	Yes			
AC surge protection	Yes(Type II)			
Ground fault monitoring	Yes			
Grid monitoring	Yes			
String monitoring	Yes			
Anti-PID function	Optional			
AFCI protection	Optional			
<b>Display and communication</b>				
Display	OLED+LED/APP			
USB	Yes			
RS485	Yes			
4G	Optional			
WIFI	Optional			
<b>General data</b>				
Dimensions (W / H / D) in mm	820*1350*510mm			
Weight	153kg	153kg	160kg	160kg
Operating temperature range	-30°C ... +60°C (> 50°C derating)			
Noise emission (typical)	≤53dB(A)	≤53dB(A)	≤65dB(A)	≤65dB(A)
Relative humidity	0-100%			
Altitude	4000m			

Model	WIT 50K-HU	WIT 63K-HU	WIT 75K-HU	WIT100K-HU
<b>Specifications</b>				
Nighttime power consumption	20W			
Standby power consumption	250W			
Topology	Transformerless			
Cooling	Fan cool			
Protection degree	IP66			
Warranty	5/10 years(Optional)			
<b>Standard compliance</b>				
Safety	IEC/EN 62109-1, IEC/EN 62109-2, IEC/EN62477-1			
EMC	EN 62920-2017			
Grid connection standards	EN50549-1, NRS 097-2-1, G99:2020, UKCA, VDE 4105, VDE4110, CEI 0-21:2019+V1:2020, CEI 0-16:2019+V1:2020, TOR Type A, VDE 0126, NC RFG, PSE-2018, PTPIREE-2021, C10/C11:2021, UNE 217001-2020, UNE 217002-2020, RD647:2020, NTS Type B			



# 11 Decommissioning the WIT Inverter

Handle the WIT Inverter that will not be operated in the future properly.

- 1> Disconnect the external AC circuit breaker and prevent accidental reconnection due to improper operation.
- 2> Set the DC switches to the OFF position.
- 3> Disconnect the upstream battery circuit breaker.
- 4> Wait at least 5 minutes before performing operations on it.
- 5> Disconnect the AC output power cables.
- 6> Disconnect the DC input power cables.
- 7> Remove the WIT inverter from the bracket if it is wall-mounted.
- 8> Dispose of the inverter according to locally applicable disposal regulations.

# Warranty 12

Growatt guarantees maintenance and replacement of the defective product under warranty.

## 12.1 Conditions

1. To serve you better, you will need to fill in a form to provide information about the product including the date of purchase and installation, the serial number of the WIT Inverter, fault description and other information.
2. Return the defective product to Growatt for recycling and disposal.

## 12.2 Disclaimer

Growatt shall not be liable for any consequences of the following circumstances:

1. Unauthorized removal of the product, such as removing the tamper-proof label and the upper cover of the WIT Inverter.
  2. Damage caused during transportation.
  3. Improper operations during installation and commissioning.
  4. Failure to observe the operation instructions regarding the installation, operation and storage of the WIT Inverter.
  5. Unauthorized modifications or improper maintenance on the WIT Inverter.
  6. Improper use and operation.
  7. Damage caused by storage conditions that do not meet the requirements specified in this manual.
  8. Failure to follow the safety precautions and applicable laws and regulations due to customer's negligence.
  9. Damage due to force majeure, such as lightning, floods, storms, fire.
- In the event of a product malfunction or failure resulting from the circumstance mentioned above, Growatt can provide paid maintenance services after conducting a fault diagnosis if required.

# 13 Contact Us

If you have technical problems with our products, please contact Growatt for technical support. Please have the following information ready in order to provide you with the necessary assistance:

1. Model number of the WIT Inverter
2. Serial number of the WIT Inverter
3. Error code of the WIT Inverter
4. Information indicated on the LED display
5. DC input voltage and AC output voltage of the WIT Inverter
6. Communication method of the WIT Inverter

**Shenzhen Growatt New Energy Co., Ltd**  
4-13/F, BuildingA, Sino-German (Europe) IndustrialPark,  
HangchengAve, Bao'anDistrict, Shenzhen, China

**T** +86 755 2747 1942

**E** [service@ginverter.com](mailto:service@ginverter.com)

**W** [www.ginverter.com](http://www.ginverter.com)