

Quick Start

for Samsung heat pumps



SAMSUNG

Mechanical Schematic

Buffer Vessel

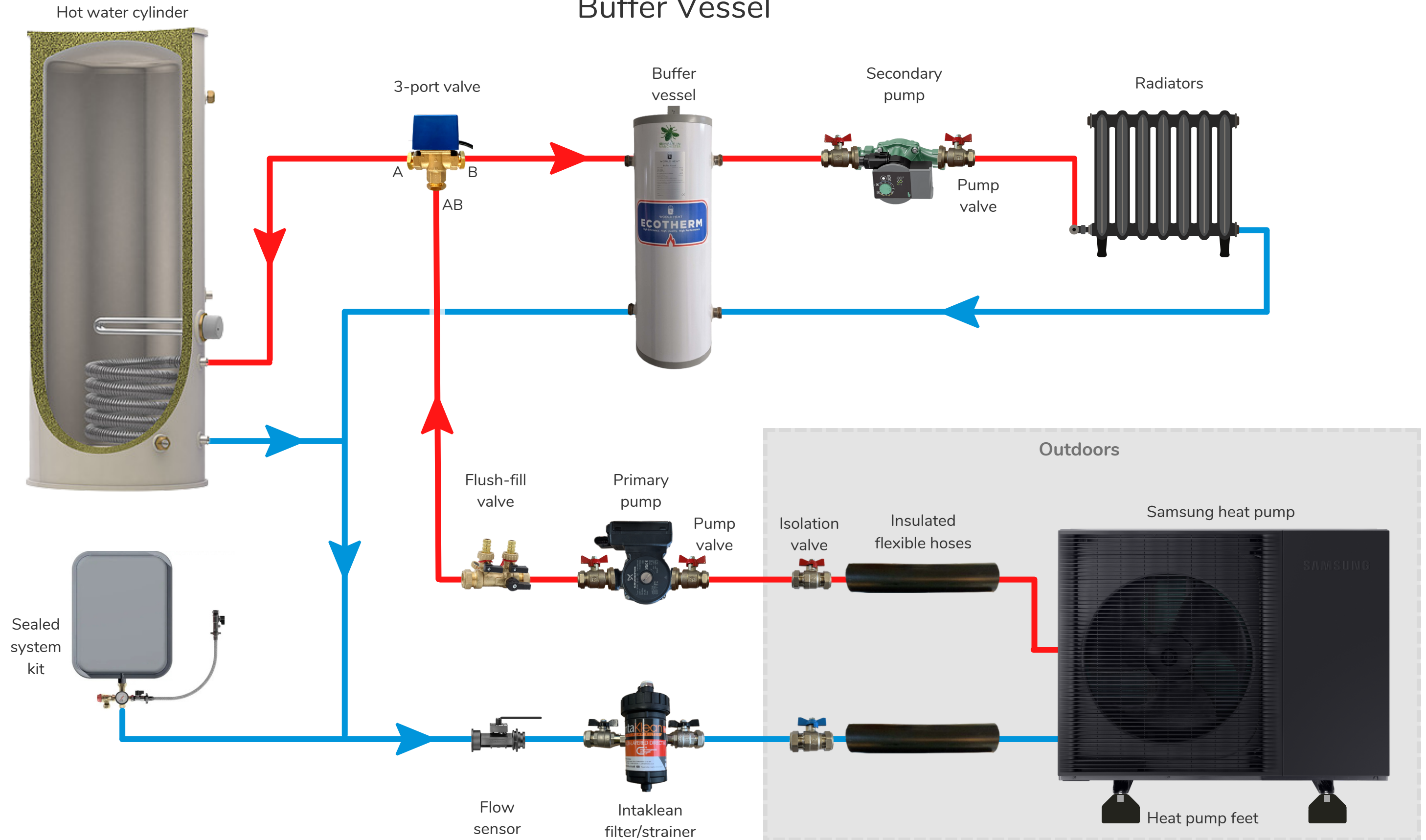

Mechanical Schematic

Direct

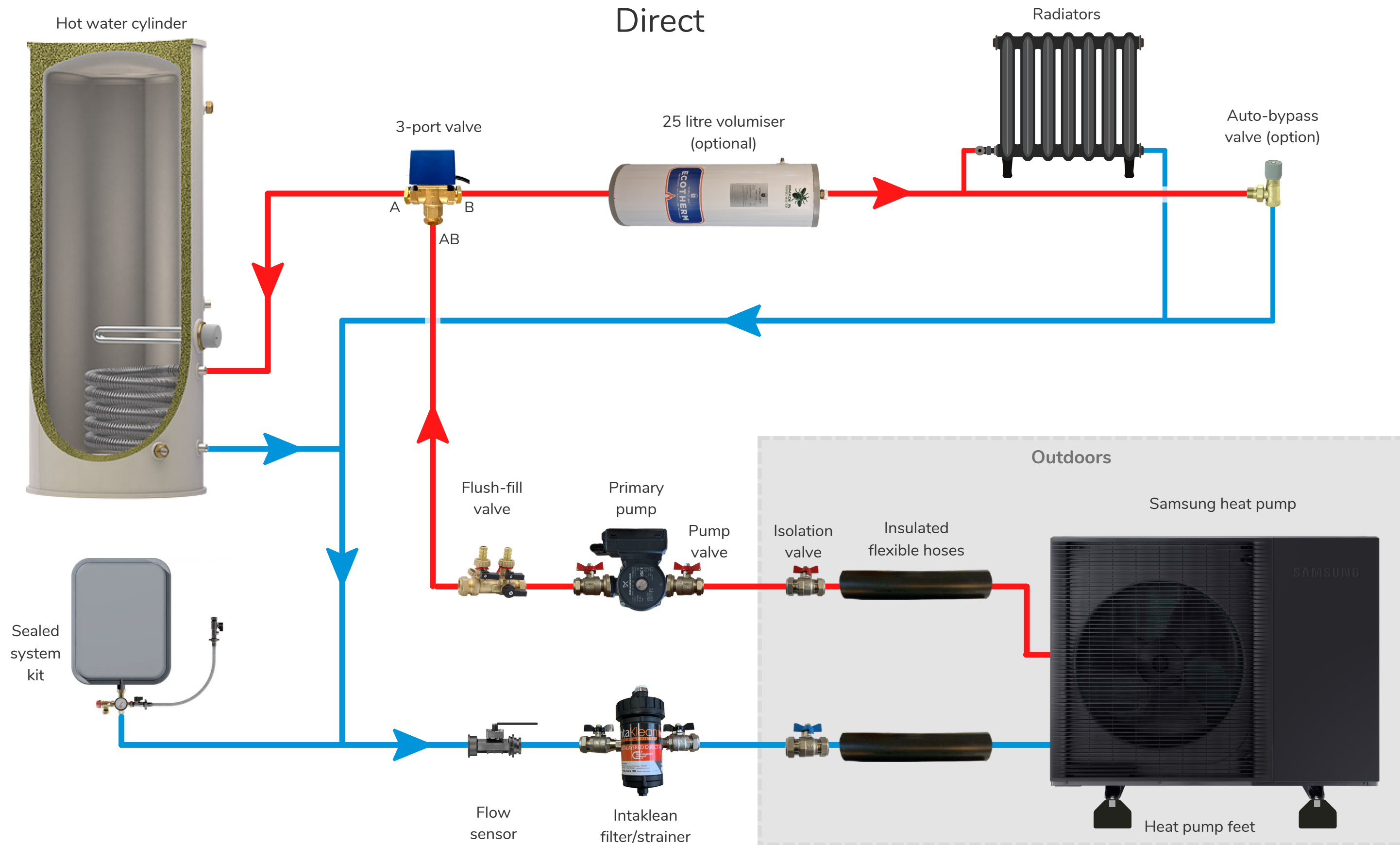

Buffers and Volumisers

The minimum circulating water content of the system is 30 litres for Samsung 5 and 8kW heat pumps and 50 litres for the 12, 14 and 16kW models.

To make it simple to always meet these requirements we can sell you a kit with either a buffer vessel or volumiser.

Buffer Vessel

A buffer vessel adds extra volume to the system and introduces flow separation between primary and secondary circuits.

We recommend a 25 litre buffer vessel for the 8kW or below heat pumps and a 50 litre buffer vessel for those rated 12kW or higher.

Larger buffer vessels are available if required.



Volumiser

A volumiser adds volume to the circuit to when doing a direct system without seapration.

We can supply a 25 litre volumiser that can be mounted vertically or horizontally.

Pumps

With Samsung heat pump we sell Grundfos OEM pumps as the primary pumps. These pumps take an external speed control signal from the Samsung board to optimise pump flow-rate for heat pump performance.



Grundfos UPM4

5 & 8kW

The Grundfos UPM4 pumps we sell have a 60W motor and 7.5m nominal head. When you're using a buffer they are good for 5 and 8kW heat pumps. They will be powerful enough for some direct systems, but you need to carry out some calculations to be sure.



Grundfos UPM4XL

12kW

The Grundfos UPM4L pumps we sell have a 60W motor and 9m nominal head. When you're using a buffer they are good for 5 and 8kW heat pumps and often for 12kW heat pumps with shorter pipe runs. They will be powerful enough for some direct systems with volumisers and bypass valves, but you need to carry out some calculations to be sure.



Wilo Yonos PICO 25/1-8 - 180 long

Secondary Pump

The Wilo Yonos PICO has a 60W motor. It is perfect as a secondary pump for moving water around your heating system.

Secondary pumps are only required when there is a buffer vessel or header.

Additional Components



Flow Sensor

The Samsung flow sensor comes in the Samsung control kit box with connecting pieces. The required flow direction is indicated on the sensor. It must be on a pipe that has the same flow as the heat pump but can be on the flow or return. It must be installed in accordance with the diagram below. The cable also connects with the cable pointing in the direction of flow.



IntaKlean heat pump filter

An IntaKlean is a filtration system which keeps the heat pump safe from any debris. It is a combined magnetic filter and strainer and connects using 28mm compression connections on the isolation valves provided. The intention is that you install them as close as possible to the heat pump on the return pipe.

This can also be replaced with a strainer or filter ball valve if you want a cheaper install or you prefer to use a brass mag filter.

Flow Sensor layout and orientation

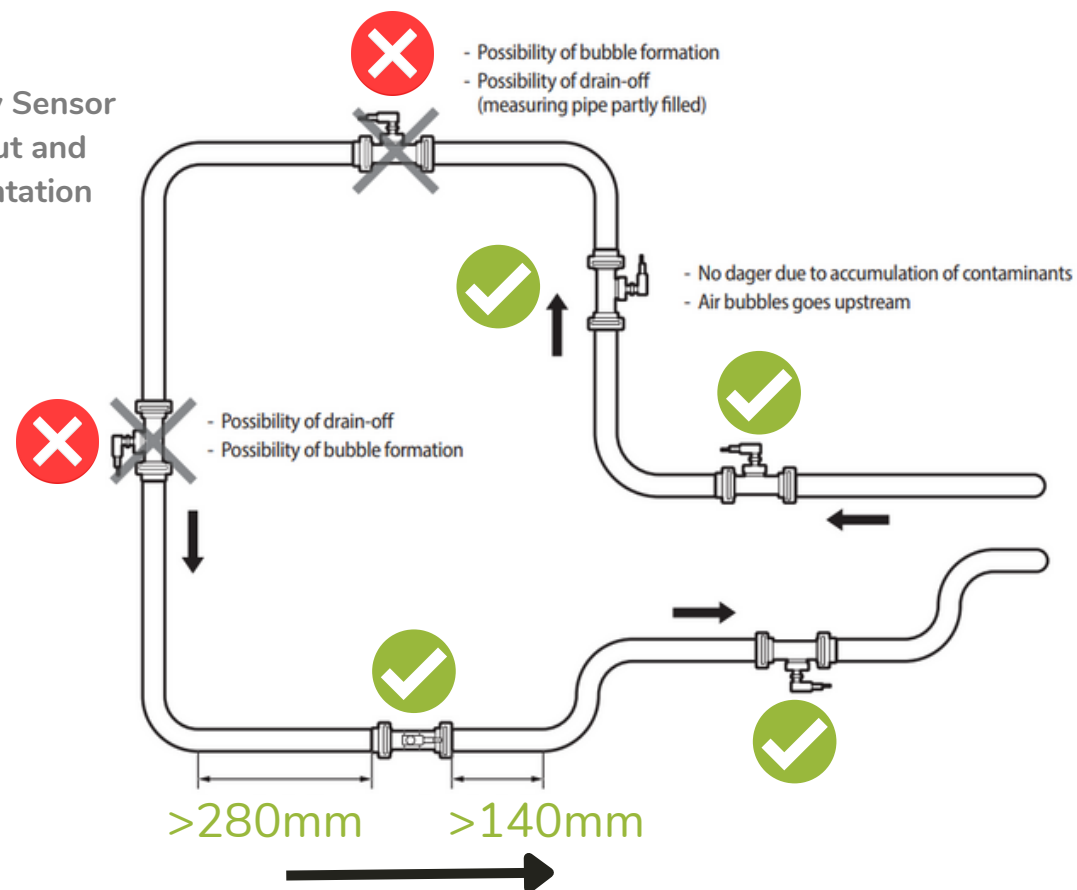

Sealed system kit

For convenience we offer 18 litre compact sealed system kit with . This is normally much more volume than you would really need for most system. If you have a very large system it is worth checking the expansion vessel sizing.

The sealed system kit comes with a pressure gauge, safety relief valve and filling loop.

Valves

3-port valve

We like to send you a Mut Meccanica 3-port valve. We select these for their very low pressure drop and to give you a 2-pole auxiliary switch. You wire the live and neutral from the board as indicated on the wiring diagram, you can wire the live via the high limit stat on the cylinder if you are doing a hybrid installation. Port A is for the cylinder, port B is for the heating.



Flush-fill valve

We supply a flush-fill valve in the kit to make it easier to flush, fill and drain the system, it needs to be installed on the primary pipework. Actually ideally it's best not to flush through the heat pump though - make a U-loop of pipe to put in the system in place of the heat pump or install a flushing bypass before the heat pump isolation valves.



Red and blue valves

A red and blue valve are normally installed for isolation of the heat pump. The colour denotes whether it is the flow or return.

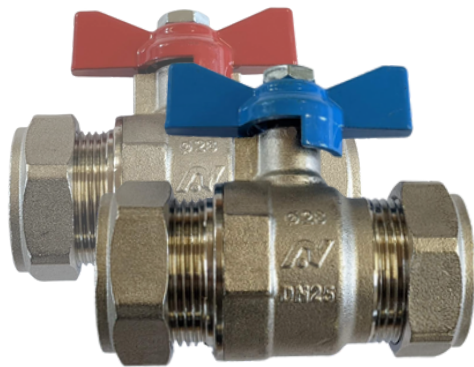

Pump Valves

These are attached either side of a pump and used to plumb it into the system, 1 pair for each pump. They have a union to connect them to the pump.

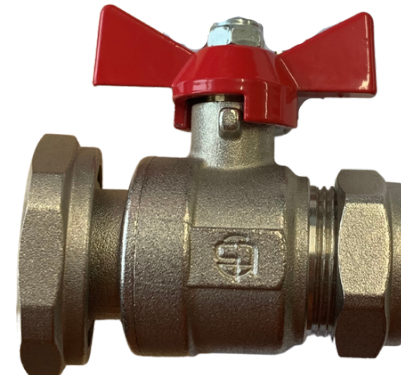

Main Power Diagram

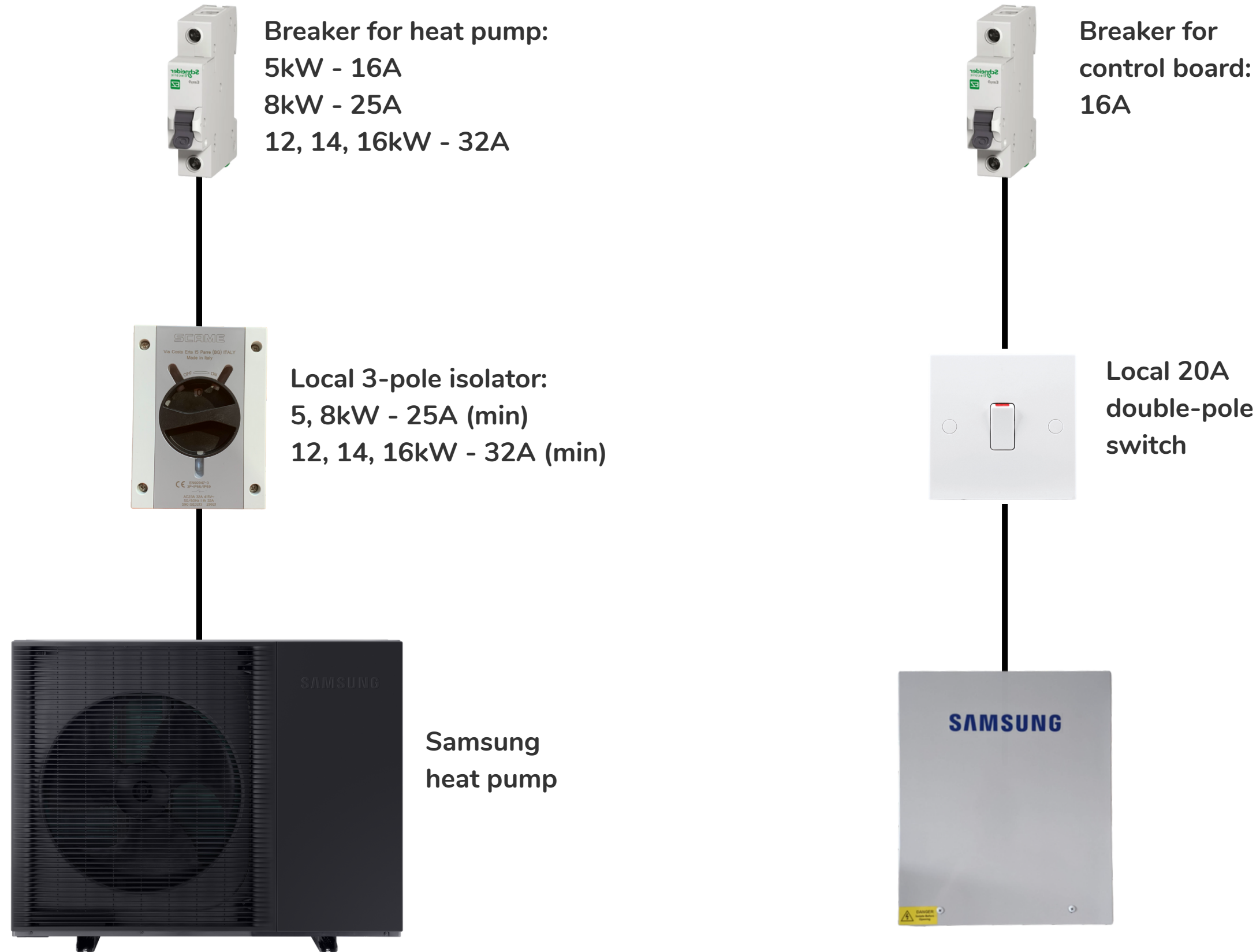

Wiring Diagram

For Samsung MIM-CN/EN
and additional components

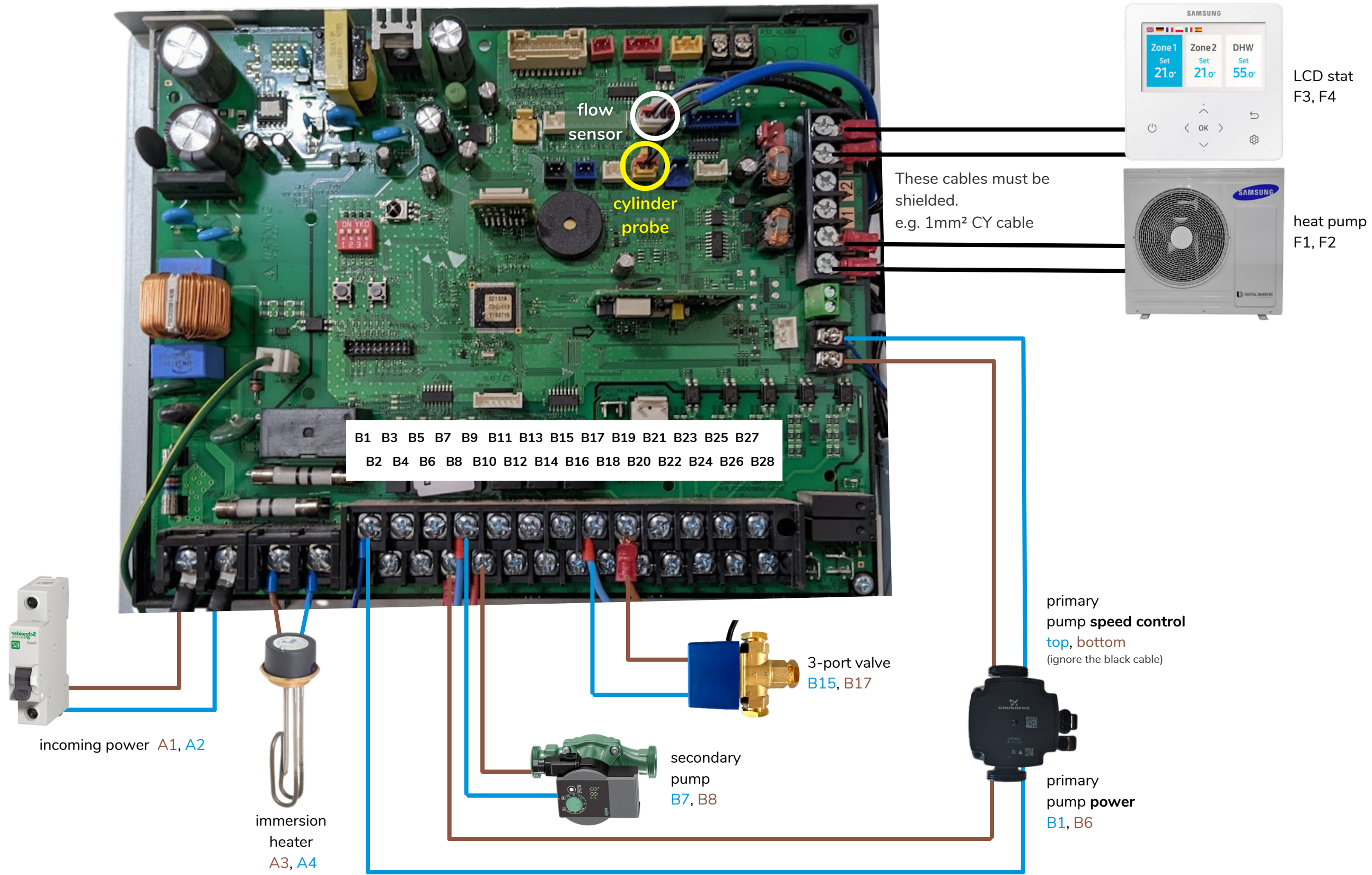

Wiring Diagram

for optional secondary pump on MIM-CN/EN

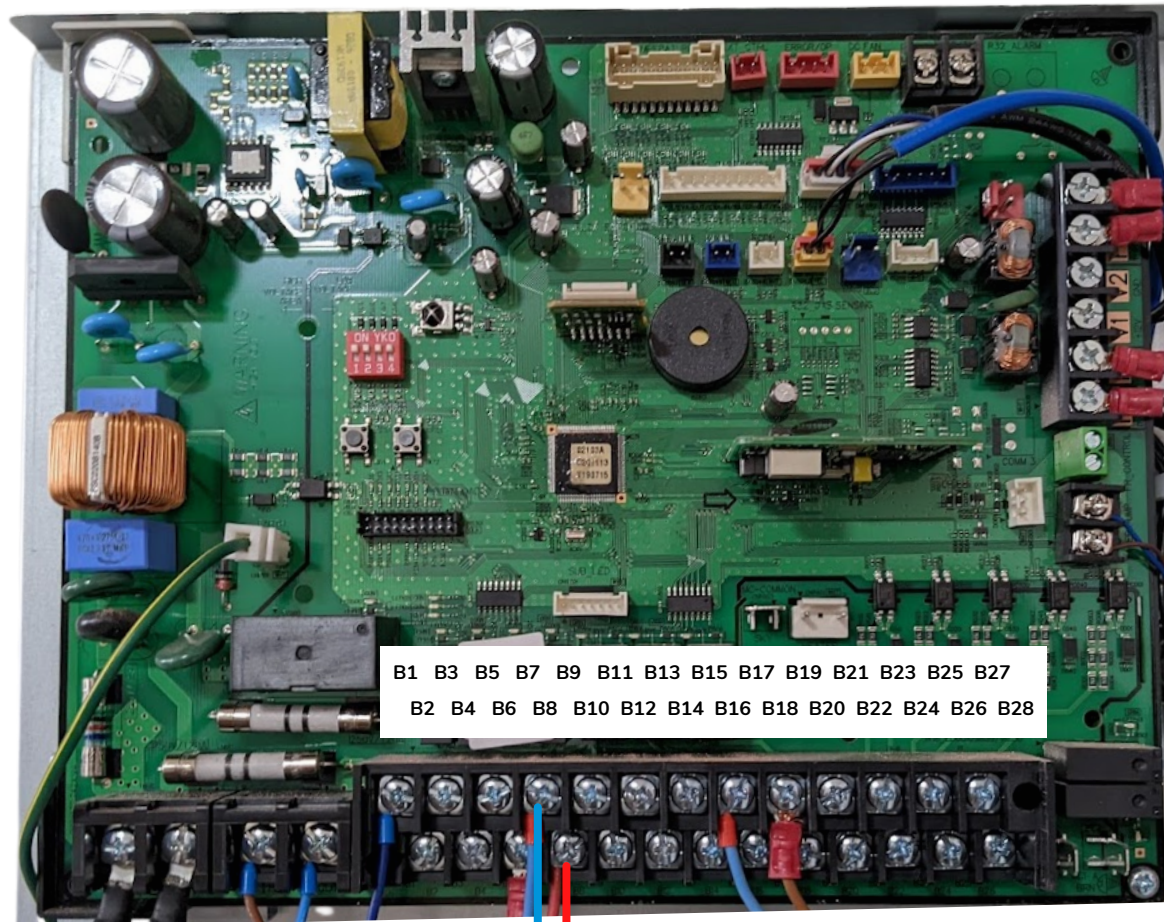

secondary pump

On the previous page the wiring diagram shows the secondary pump wired directly on to B7 and B8. If you do this the secondary pump runs any time the heat pump is running - in heating mode and in hot water mode.

What's good about that is:

- in heating season it continues to circulate the hot water from the buffer when the heat pump is doing a hot water run.
- it's simple to wire and robust.

What's bad about that is:

- in summer the secondary pump runs during each hot water cycle and this uses a few pounds worth of electricity each year.
- if the aux switch breaks, the secondary pump stops running.

You can wire the secondary pump up via the auxiliary switch in the 3-port valve as show on this page and then the secondary pump will only run when the heat pump is on and in heating mode.

YOU MUST STILL WIRE THE LIVE AND NEUTRAL TO THE 3-PORT VALVE MOTOR (B15, B17)

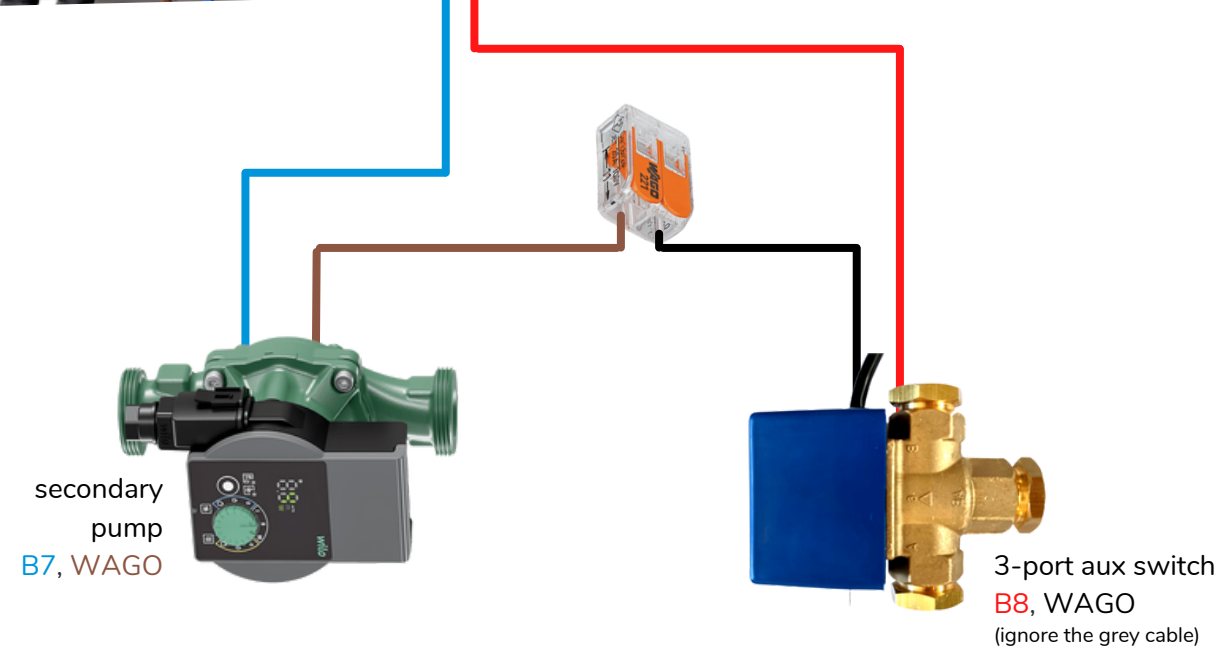

Set the time

Where you go to set the time on the controller is:
User Mode then **Wired remote controller** then you can set the **Current Time**.

Accessing service mode

To get into service mode for testing and setting up the heat pump you need to press and hold **up and down** for 5 seconds. The controller will then ask you to enter the PIN which is **0 2 0 2**

Check the flow-rate

Enter Service Mode, go to **Indoor Zone Option** then **Indoor Zone Status Information** and it will show a value for **flow sensor** in litres per minute.

Samsung Thermostat

The heat pump control is a bit more clever when you use the Samsung controller as the thermostat. This is the ideal option if you can find a route for the cable to a sensible thermostat location.

To use the Samsung LCD controller as the thermostat enter service mode and go to:

Indoor Zone Option

and set

Standard Temperature to Indoor

Now the controller is set up to act as the thermostat with the temperature setting via the Samsung LCD.

External Thermostat

If you need to use an external, 3rd party thermostat with a Samsung heat pump this needs to be wired up as shown below. Permanent live is **B20**, switched live is **B22**.



Then set the heat pump to use it as the signal to heat or not by setting **FSV 2091** - External Thermostat Application #1 (Floor) to **Use(Signal ON/OFF) or WL Interlink OFF(Water Pump3)**.

Heating - Weather Compensation

Samsung's name for weather compensation is "water law". You need to set up the water law before the heat pump will perform weather compensation properly. On a Samsung you set a warm weather point and a cold weather point and then the unit interpolates between them to provide the flow temperature asked for.

To do this you need to enter service mode, "Field Setting Value" and input the settings.

20** Water Law

201* Outdoor Temp. for Water Law (Heat)

Low = 20°C

High = -3°C

202* Water Out Temp. for WL1 Heat (WL1-Floor)

Low target value

25°C

High target value

45°C

Note: the two numbers inside the green boxes are the design condition, in this case shown as flow temp of 45°C at air temp of -3°C but you should use the temperatures you have designed to.

Hot water settings (FSV)

3011 - Domestic Hot Water Tank - **Use(Hysteresis Thermo ON/OFF state)**

3025 - Max DHW Operation Time - you want to give your heat pump a decent chance of heating the water up in one go here, but not let the house get cold while you do it. If it's a well insulated house you can set this time fairly long, if it's a poorly insulated house you can set it shorter. **90 minutes** is a reasonable starting point for most cases.

3032 - Delay time - This is how long the heat pump tries to do the hot water using the heat pump before it kicks in the immersion heater to help. You don't really want this to happen often so set this to **60 minutes**.

3042 - This is the day that the legionella cycle happens. Best idea is to set it mid-week probably **Tuesday** or **Wednesday**.

3043 - Legionella start time - Set this to a time where the water should already be hot anyway to minimise the energy used for this cycle, maybe **4am**.

3044 - Target temp - This is how hot the heat pump goes in legionella cycle - **60°C** is a good setpoint normally. If the occupants are older you might want to go for 65°C to be extra safe.

