

**EN** INSTALLATION INSTRUCTIONS

## Free Standing Mounting System TRIC F

**ES** INSTRUCCIONES DE MONTAJE

## Estructura de montaje para tejado plano TRIC F

**IT** ISTRUZIONI DI MONTAGGIO

## Struttura di supporto per piano TRIC F

**EN** **Important Notes**

- The dimensioning of the mounting system (number of mounting triangles) should be specifically carried out for each individual project, following the specified structural engineering standards and regulations.
- Prerequisite for the proper application always is a solid mounting base that can accommodate the occurring forces (weight, wind and snow loads).
- The installation instructions of the solar module manufacturers must be adhered to.

**ES** **Observaciones importantes**

- Hay que realizar el dimensionamiento del sistema de montaje (número de triángulos) según cada proyecto y conforme con la normativa vigente.
- Comprobar las condiciones de suelo o tejado que va a soportar las fuerzas de nieve y viento.
- Las instrucciones de instalación del fabricante de los módulos deben ser cumplidas.

**IT** **Informazioni importanti**

- Il dimensionamento del sistema di montaggio (Numero dei triangoli di supporto) deve essere eseguito considerando le norme rispettive.
- Deve essere garantita un'adeguata sottostruttura per il montaggio cioè di una sottostruttura in grado di sostenere le forze (peso proprio, carico di vento e di neve) che si verranno a creare.
- Rispettare le prescrizioni di montaggio del produttore dei moduli.

**TRIC F**

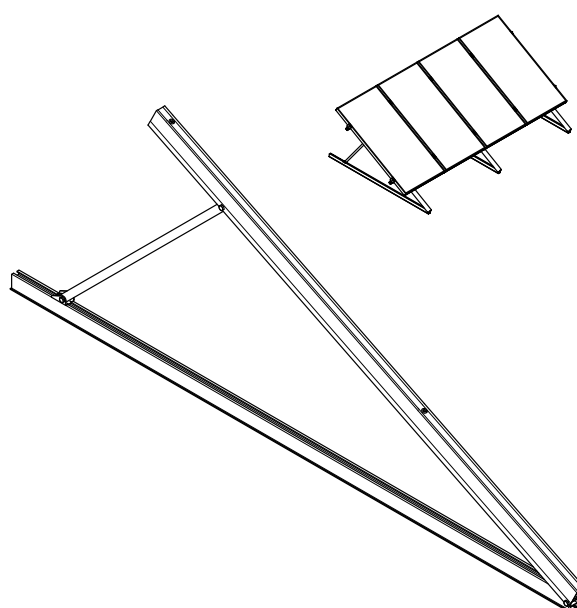

**TRIC F Quer**

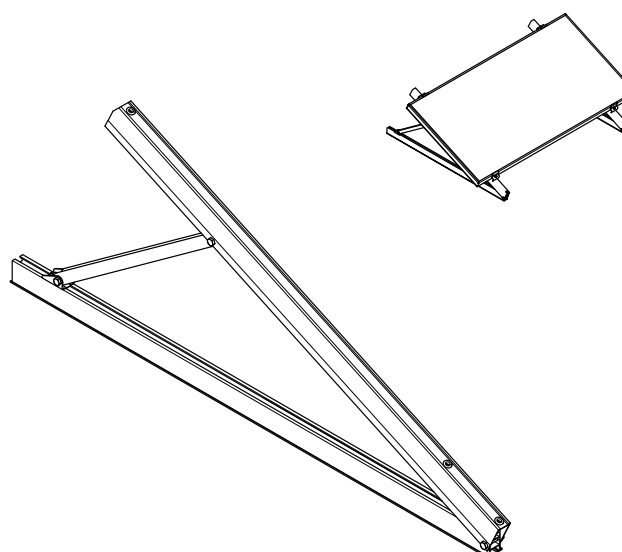

**TRIC F**

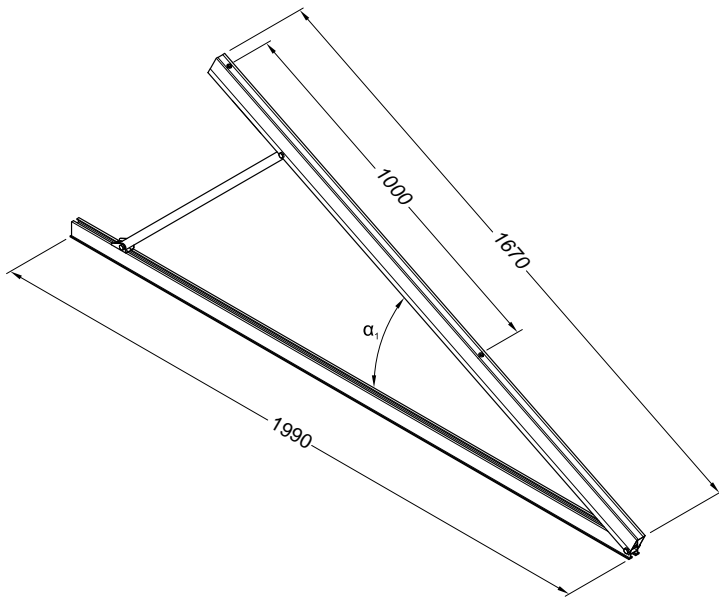

**TRIC F Quer**

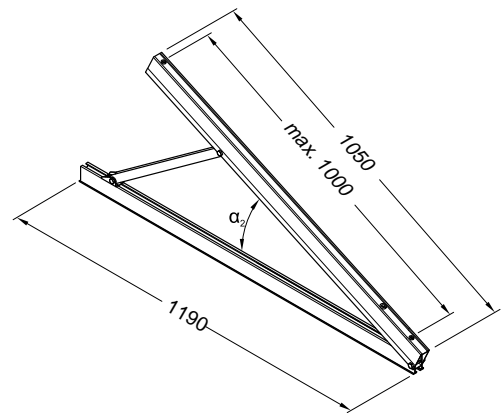

TRIC F	$\alpha_1$
TRIC F 15	15°-22°
TRIC F 30	22°-38°
TRIC F 45	38°-60°

TRIC F Quer	$\alpha_2$
	18° - 43°

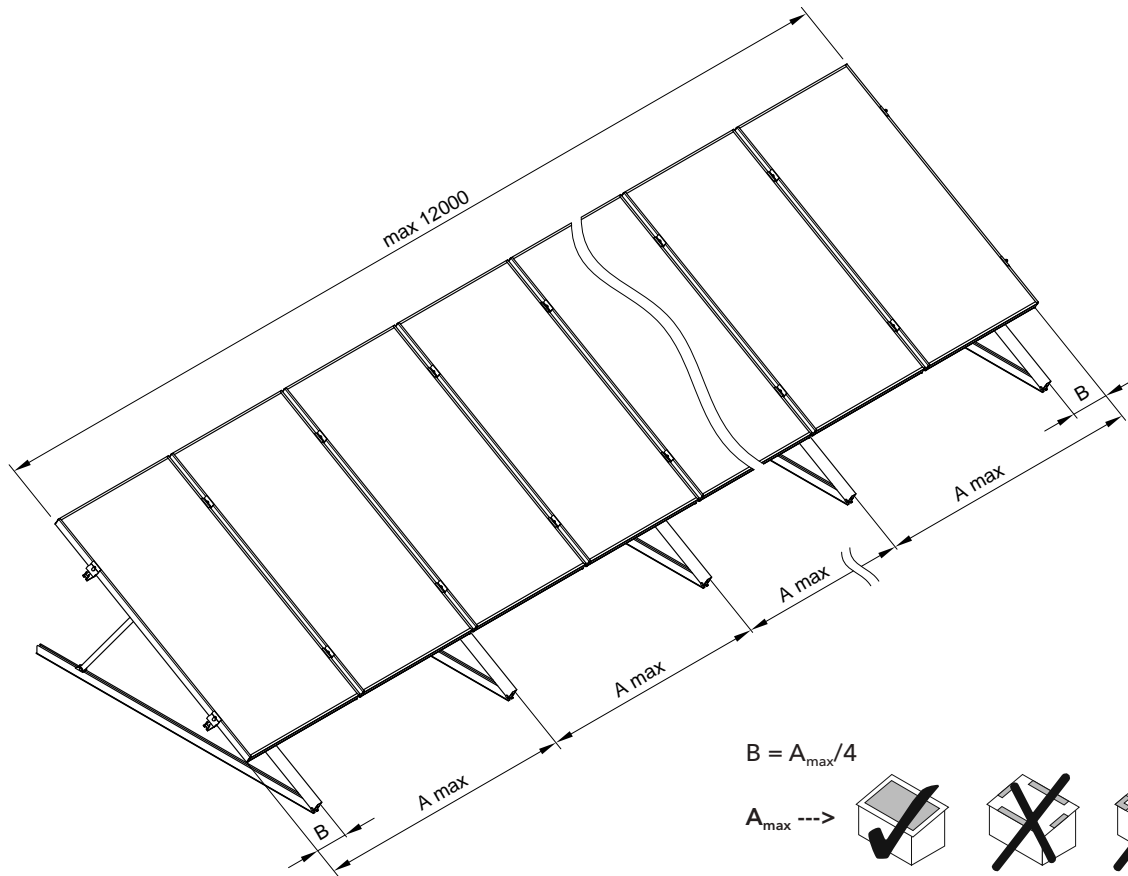

(EN) (ES) (IT)									
$v_{ref}$ [m/s]	H = 0 - 300 m		H = 300 - 500 m		H = 500 - 700 m		H = 700 - 900 m		
	$S_0$ [kN/m <sup>2</sup> ]	$A_{max}$ [mm]	$S_0$ [kN/m <sup>2</sup> ]	$A_{max}$ [mm]	$S_0$ [kN/m <sup>2</sup> ]	$A_{max}$ [mm]	$S_0$ [kN/m <sup>2</sup> ]	$A_{max}$ [mm]	
22,5	0,81	1.720	1,04	1.500	1,63	1.200	2,37	920	
25,0	0,89	1.500	1,60	1.090	2,58	860	3,83	630	
30,0	0,89	1.090	1,60	920	2,58	710	3,83	550	
25,0	1,11	1.330	2,00	1.000	3,23	710	4,78	520	
25,0	1,29	1.200	2,37	860	3,86	630	5,76	460	
30,0	1,29	1.000	2,37	750	3,86	570	5,76	410	

TRIC F 30° / <10m

H = meters above sea level / metros sobre el nivel del mar / metri sul livello del mare  
 $S_0$  = ground snow load / carga de nieve en suelo / Carico di neve al suolo  
 $v_{ref}$  = reference wind speed / velocidad del viento de referencia / Velocità vento di riferimento

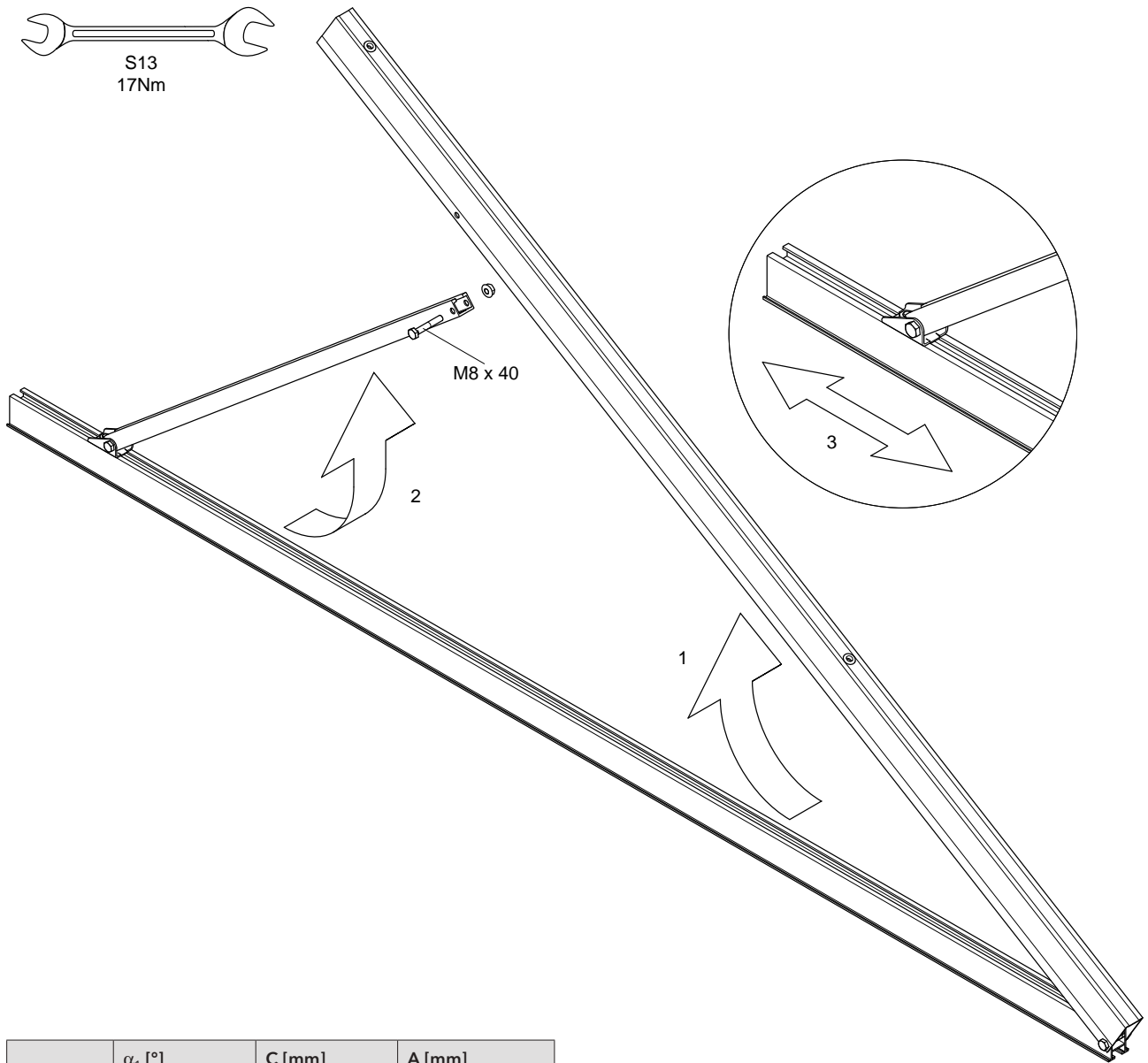

	$\alpha_1$ [°]	C [mm]	A [mm]
TRIC F 15	10	168	500
	15	271	670
	20	464	820
TRIC F 30	25	105	970
	30	278	1.120
	35	525	1.250
TRIC F 45	40	89	1.378
	45	274	1.493
	50	486	1.597
	55	734	1.689
	60	1.071	1.768

	$\alpha_2$ [°]	C [mm]	A [mm]
TRIC F Quer	20	16	470
	25	79	550
	30	159	620
	35	261	690
	40	403	760

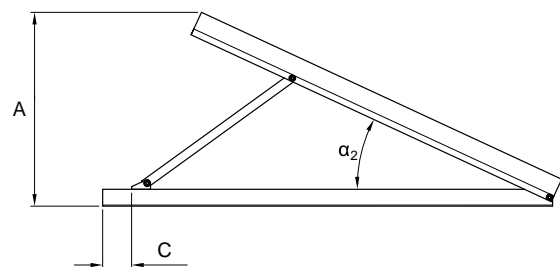
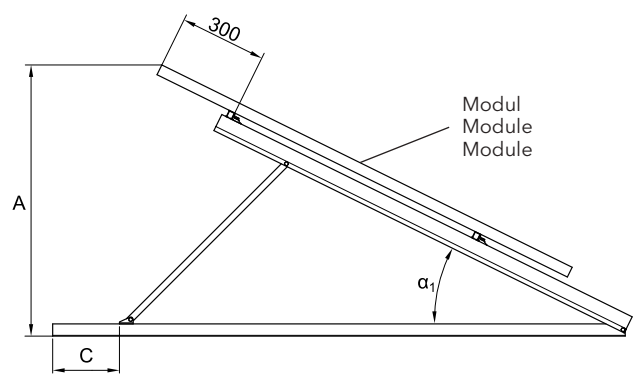

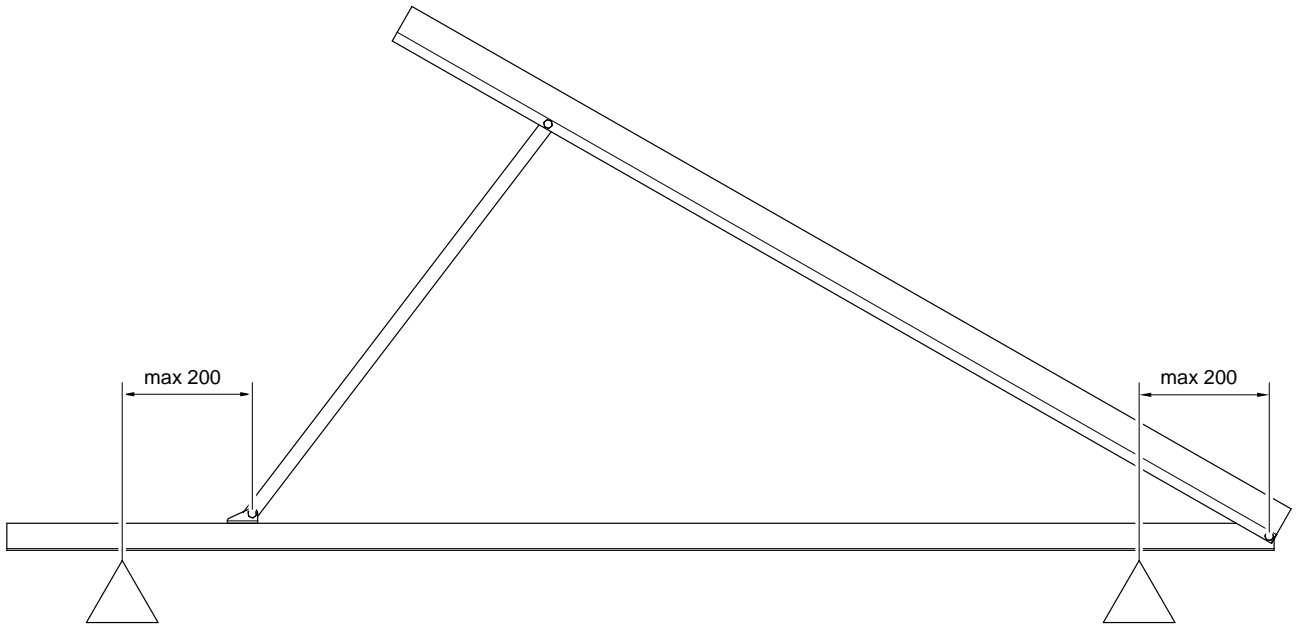

**Mounting on steel beams / Montaje en vigas de acero / Installazione su portanti in acciaio**

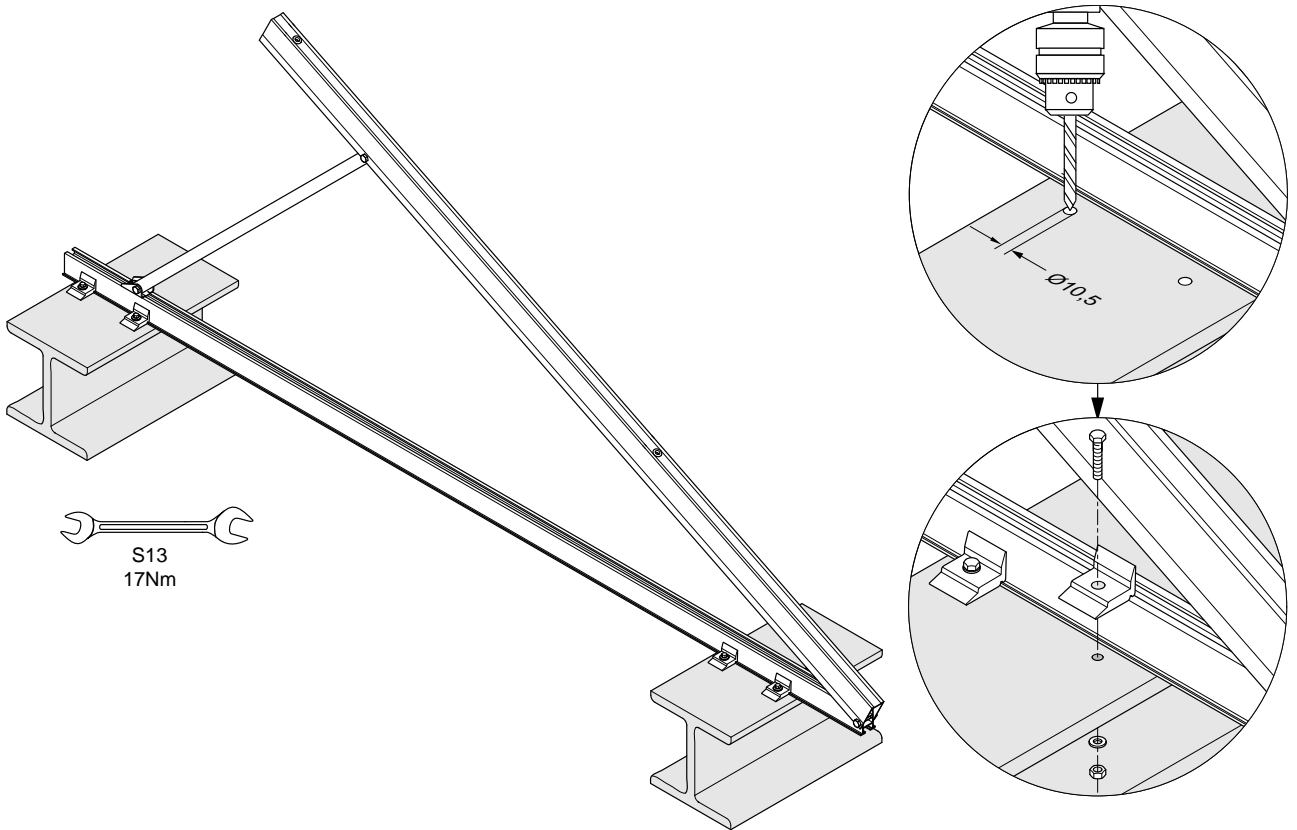

Mounting on pan tiles / Montaje en tejados de tejas / Installazione su coperture a tegole

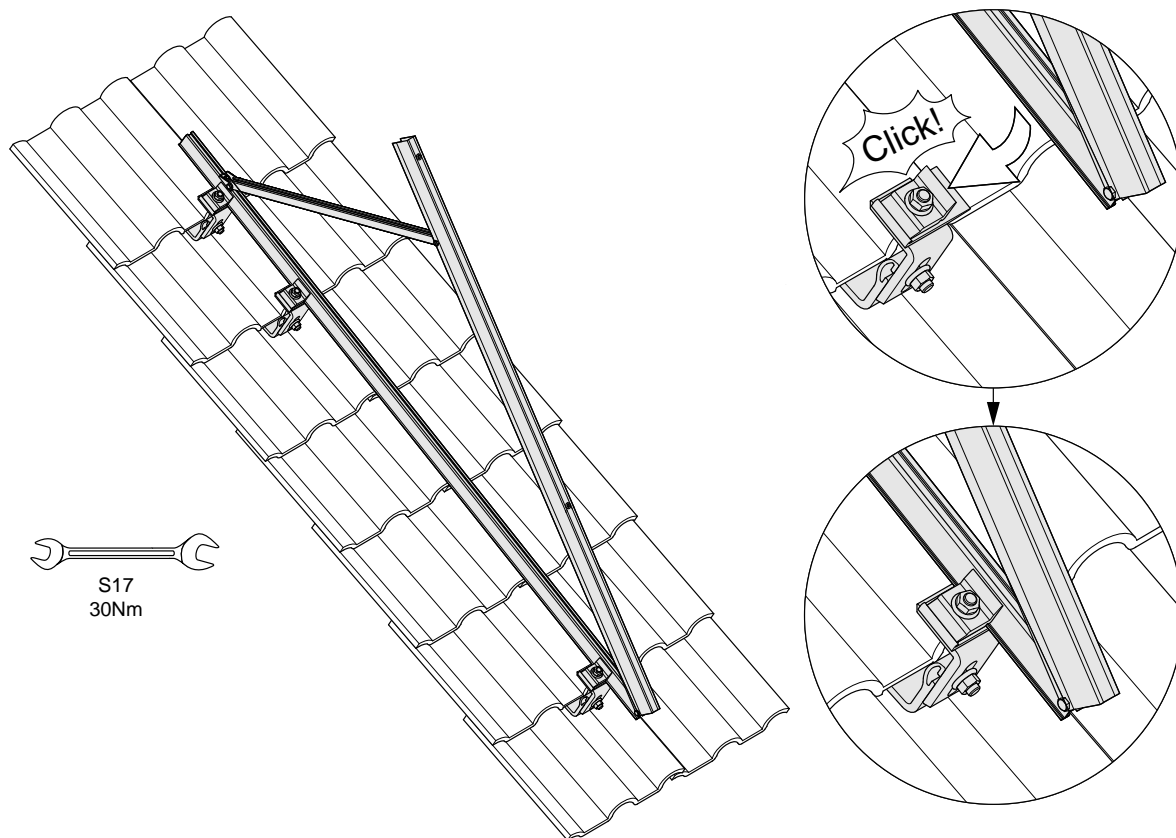

Mounting concrete bricks / Montaje en losas de hormigón / Installazione su blocchi di cemento

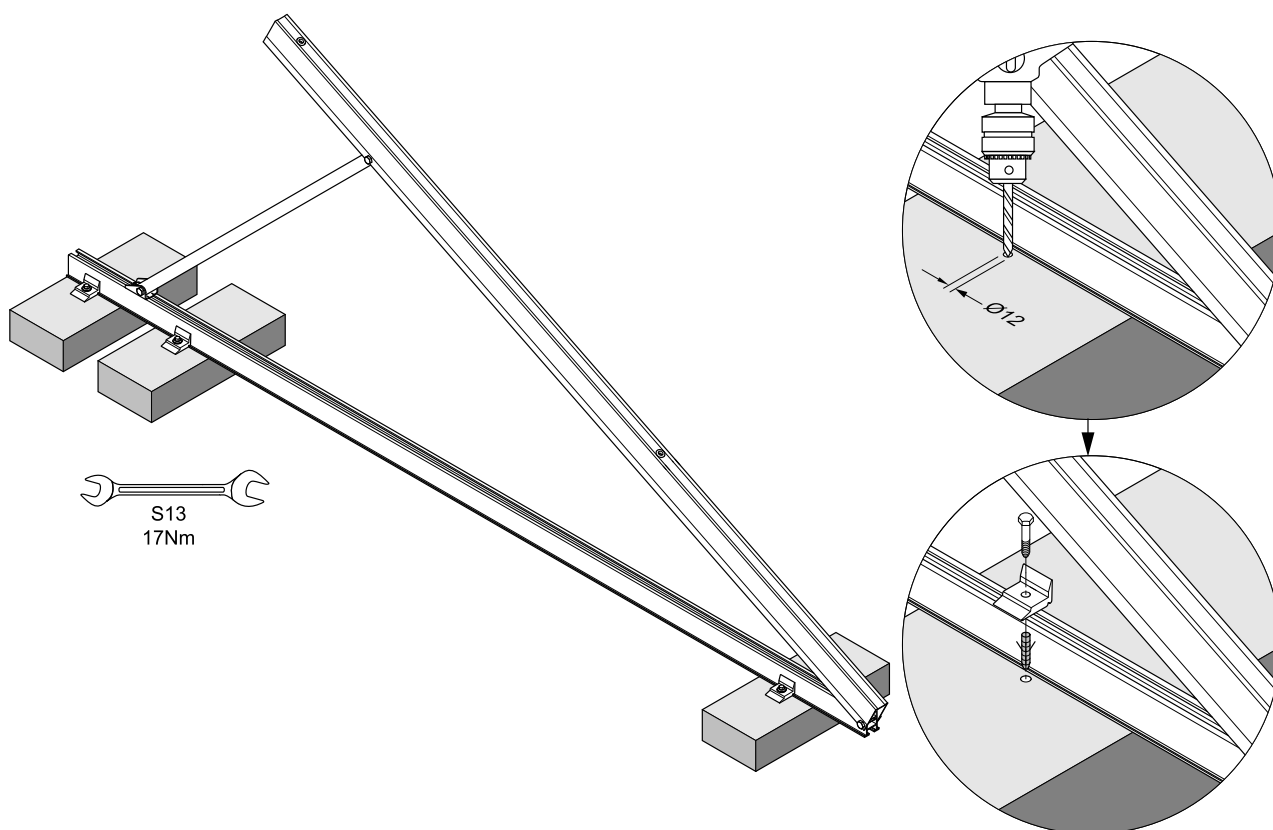

Mounting on gravel base plate set / Montaje en chapa de grava / Installazione su piastre portagliaia

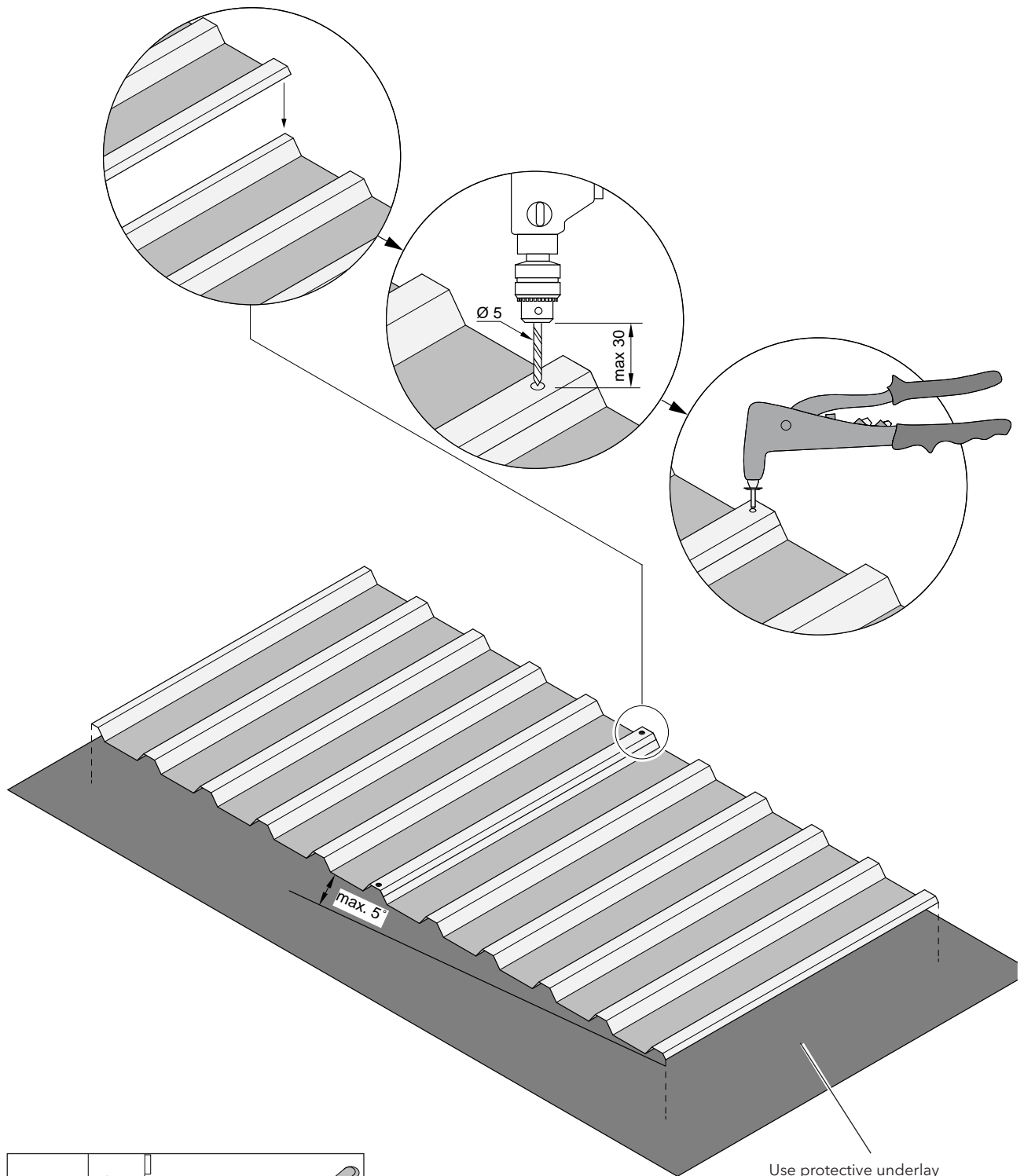

Use protective underlay

Ponga debajo una estera de protección

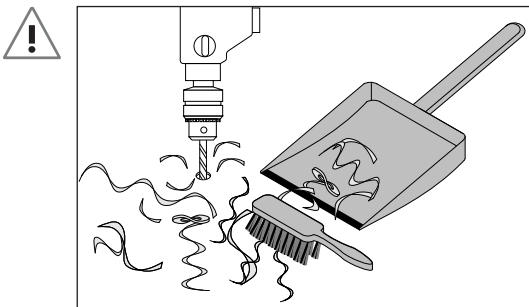

Mettere sotto la stuoia per la protezione della costruzione

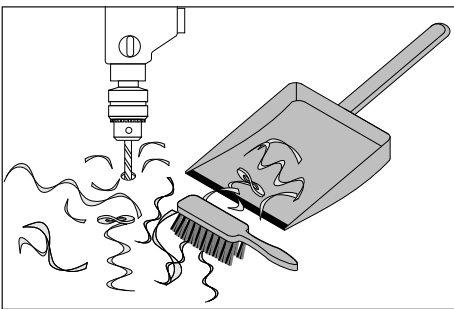
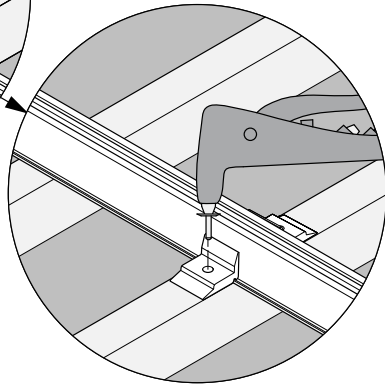
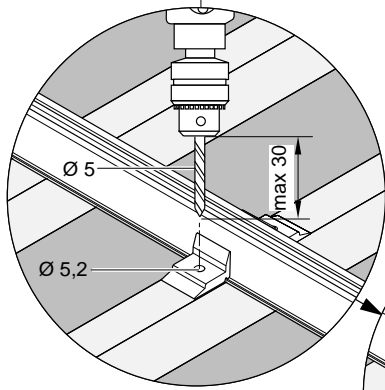
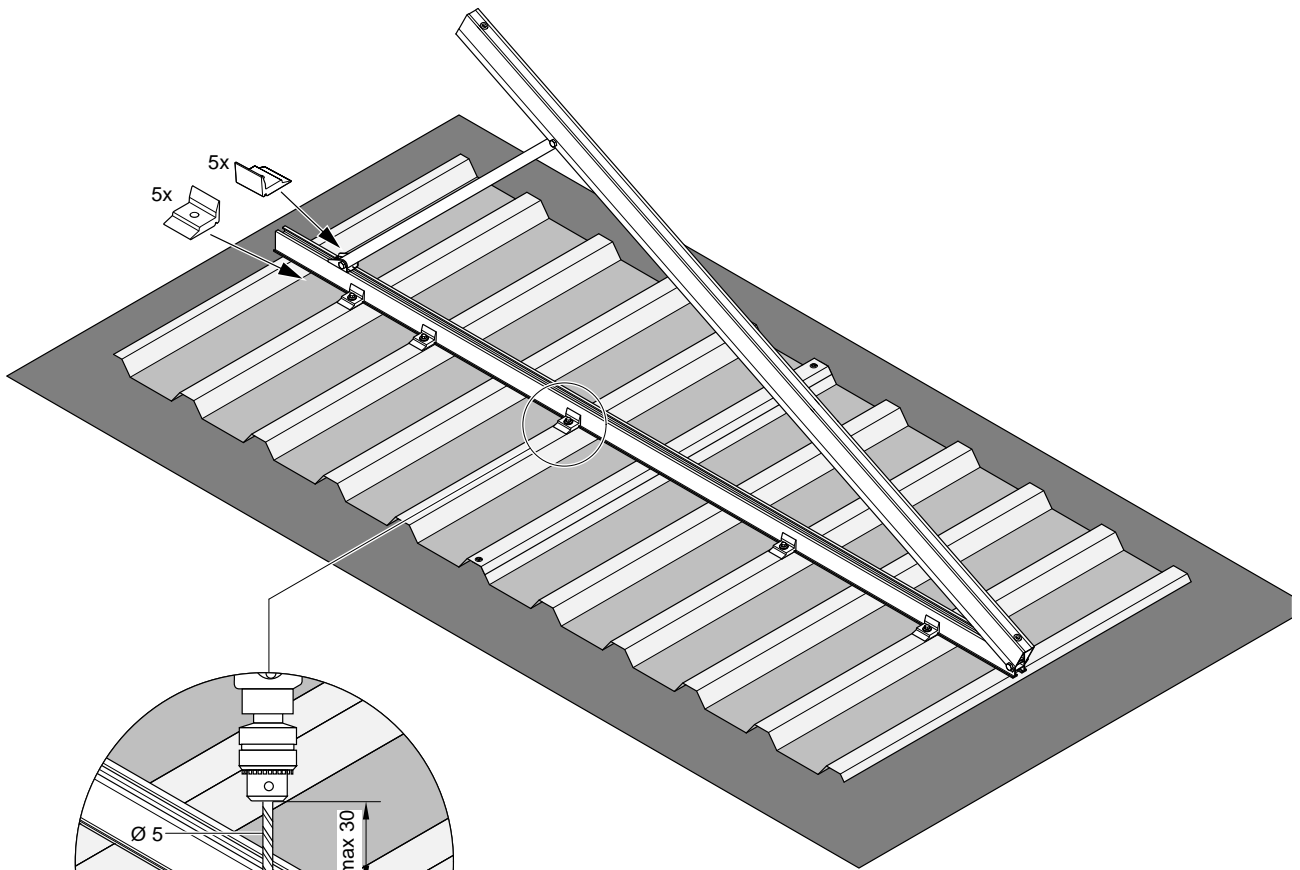



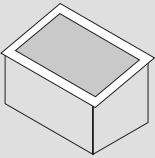
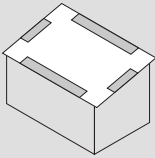
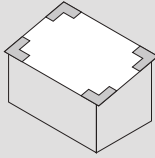

(EN) (ES) (IT)	Gravel load / Carga de grava / Zavorra necessaria G [kg]		
			
$v_{ref}$ [m/s]			
22,5	105	172,5	232,5
25,0	135	217,5	285
27,5	172,5	270	352,5
30,0	210	330	427,5

TRIC F 30° /  <10m /  < 800m (inland / interior / interno)

$v_{ref}$  = reference wind speed / velocidad del viento de referencia / Velocità vento di riferimento  
 G = Gravel load in kg per m<sup>2</sup> module surface, incl. safety factor acc. to DIN 1055-100  
 Carga de grava en kg por m<sup>2</sup> superficie de módulo incl. coeficiente de seguridad según DIN 1055-100  
 Zavorra necessaria in kg per m<sup>2</sup> di superficie moduli, considerati i coeff. di sicurezza secondo la Norma DIN 1055-100

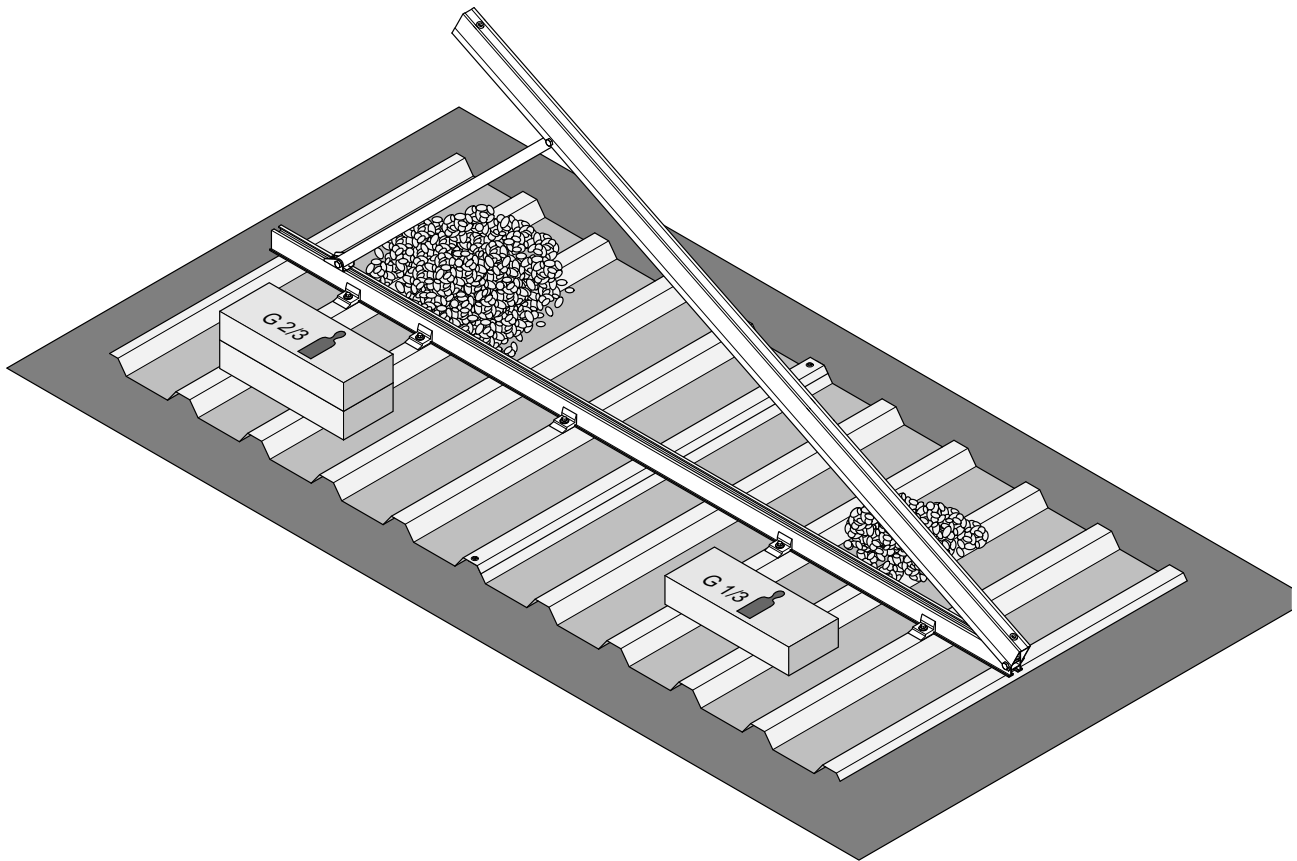

Installation across the roof pitch / Instalación transversal a la inclinación del techo / Installazione perpendicolare alla pendenza della falda

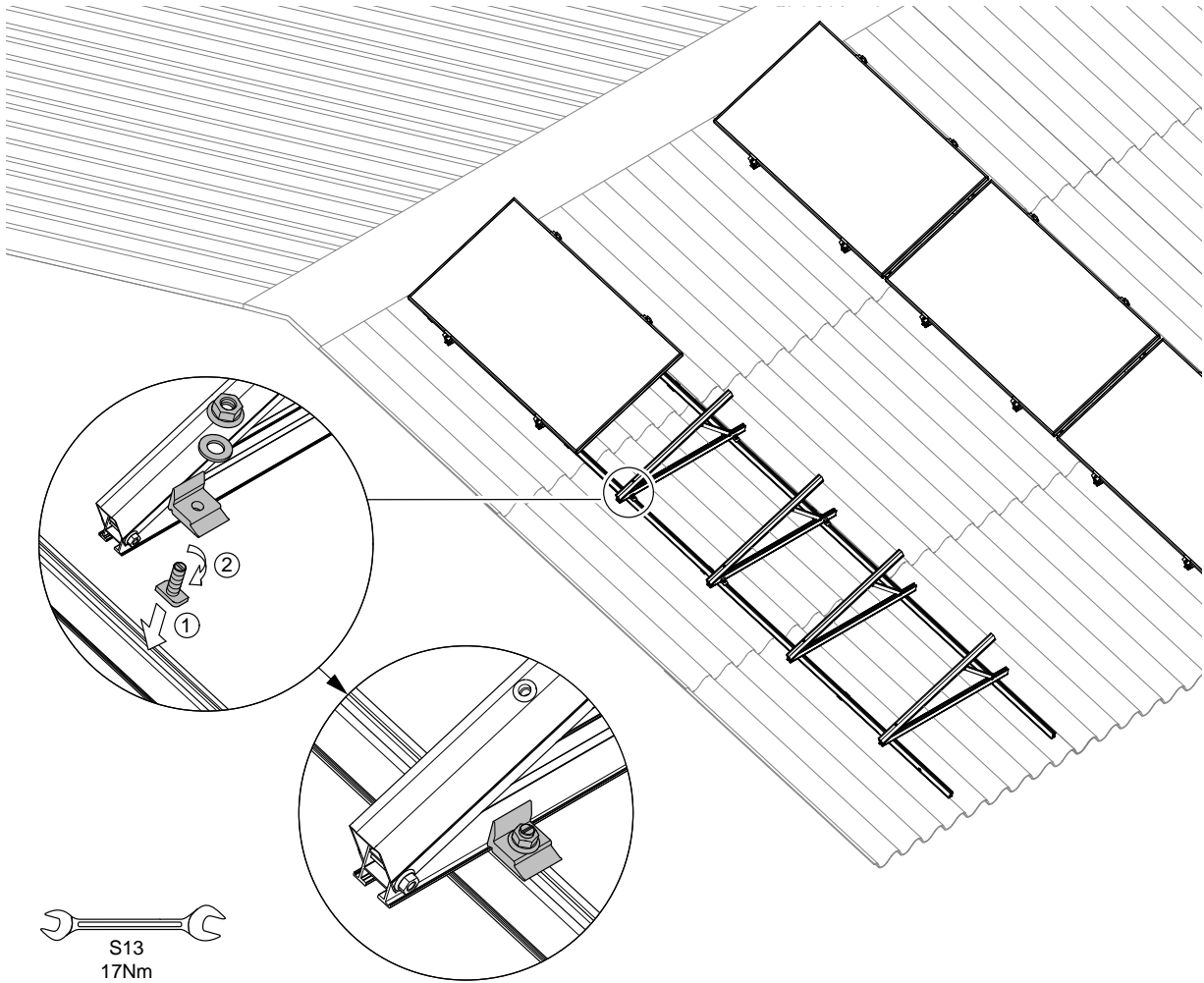

TRIC F Module installation / Montaje de módulos / Montaggio moduli

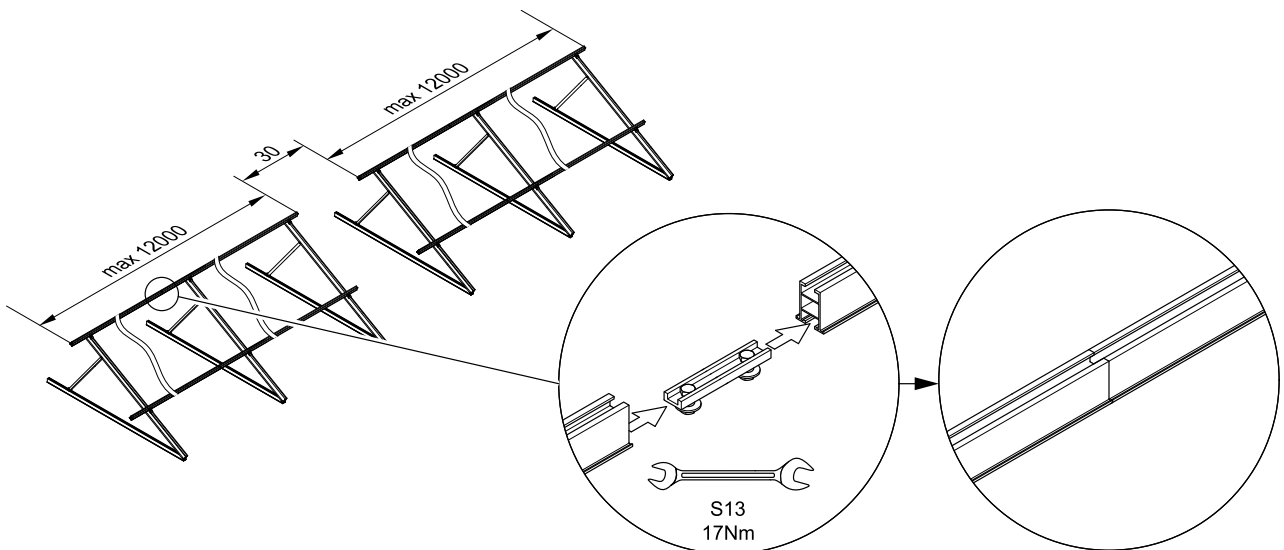
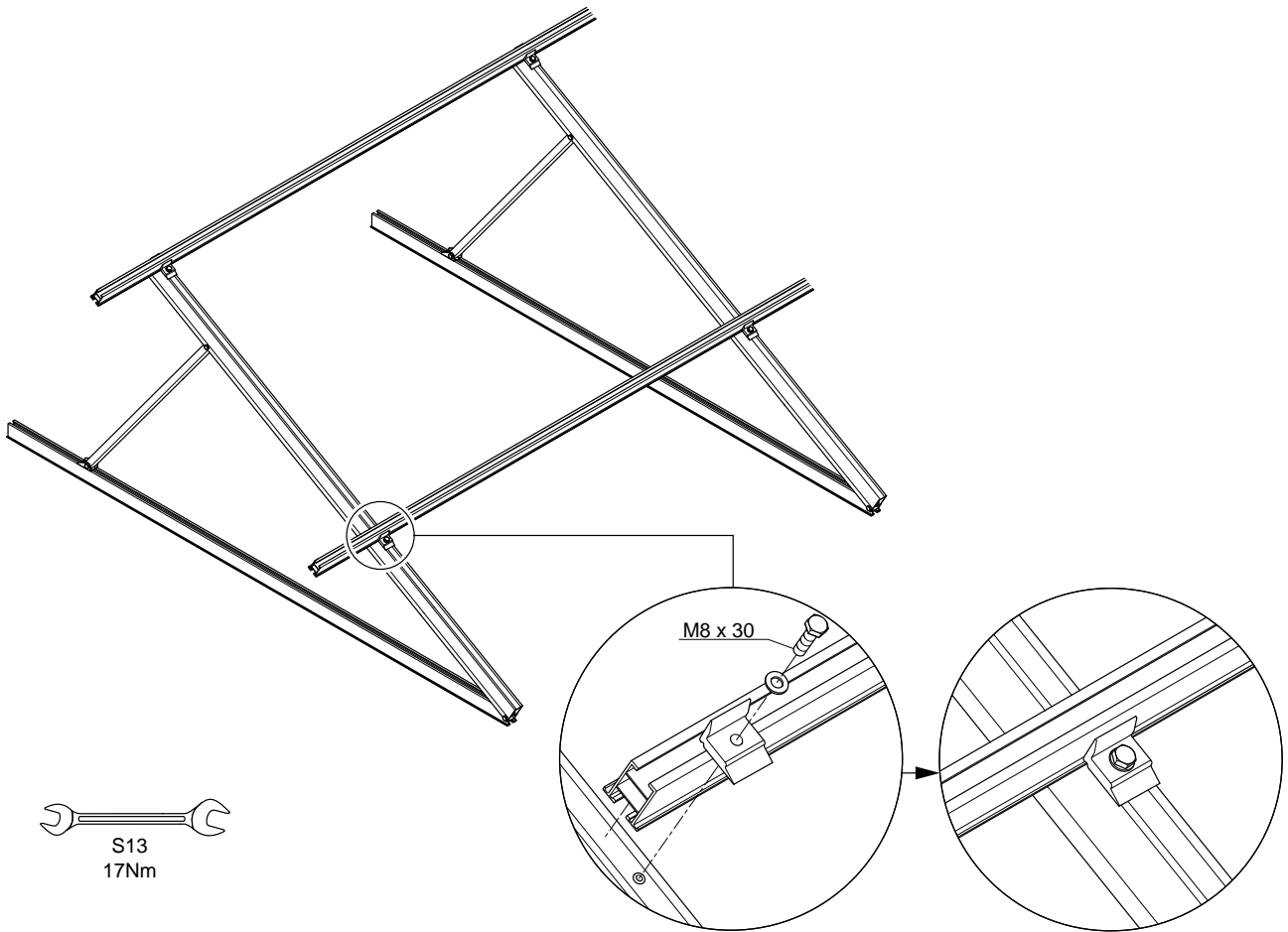

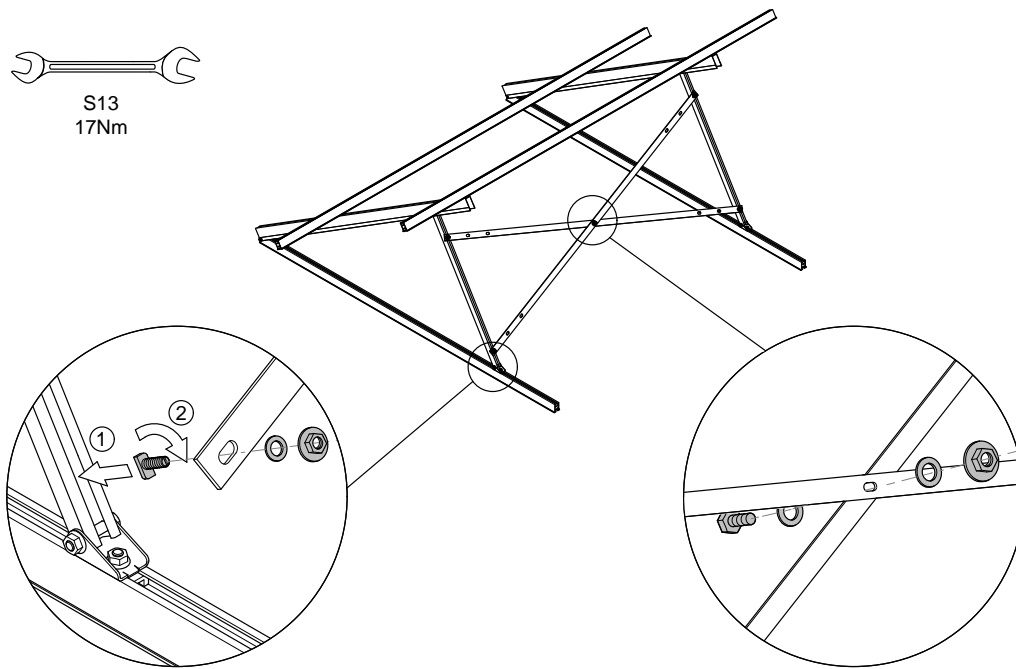
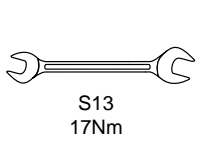
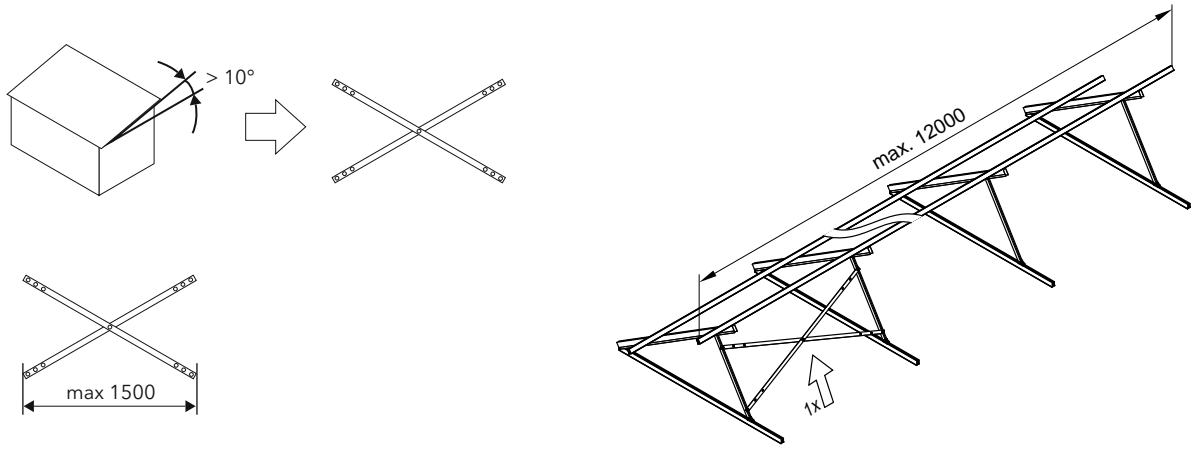

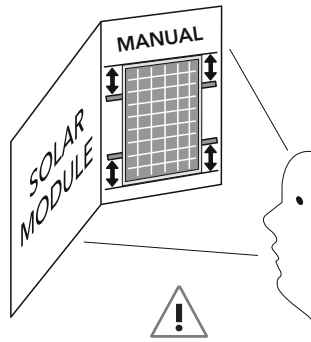
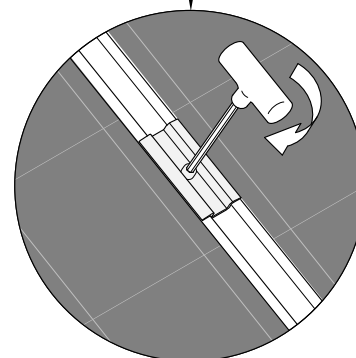
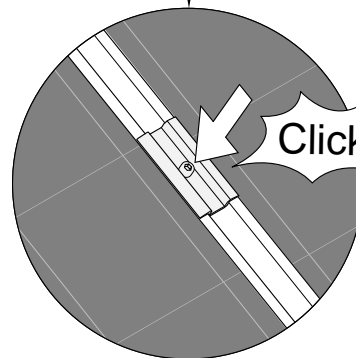
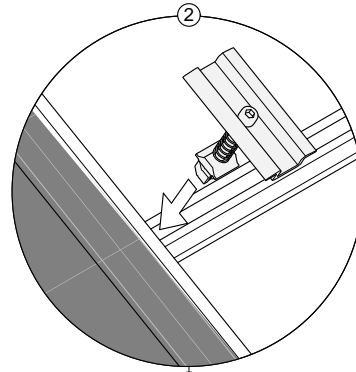
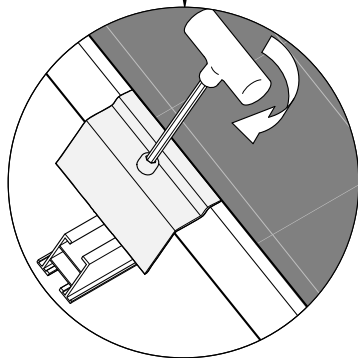
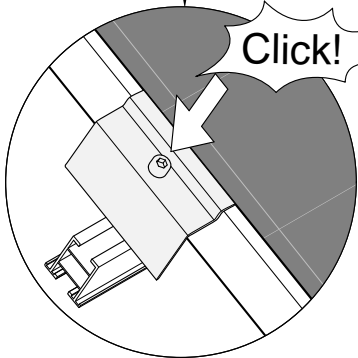
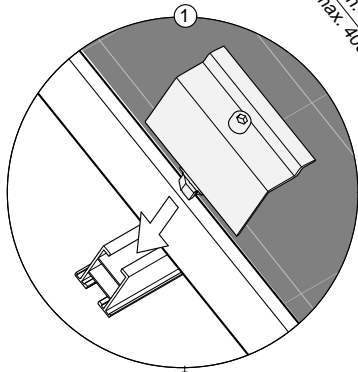
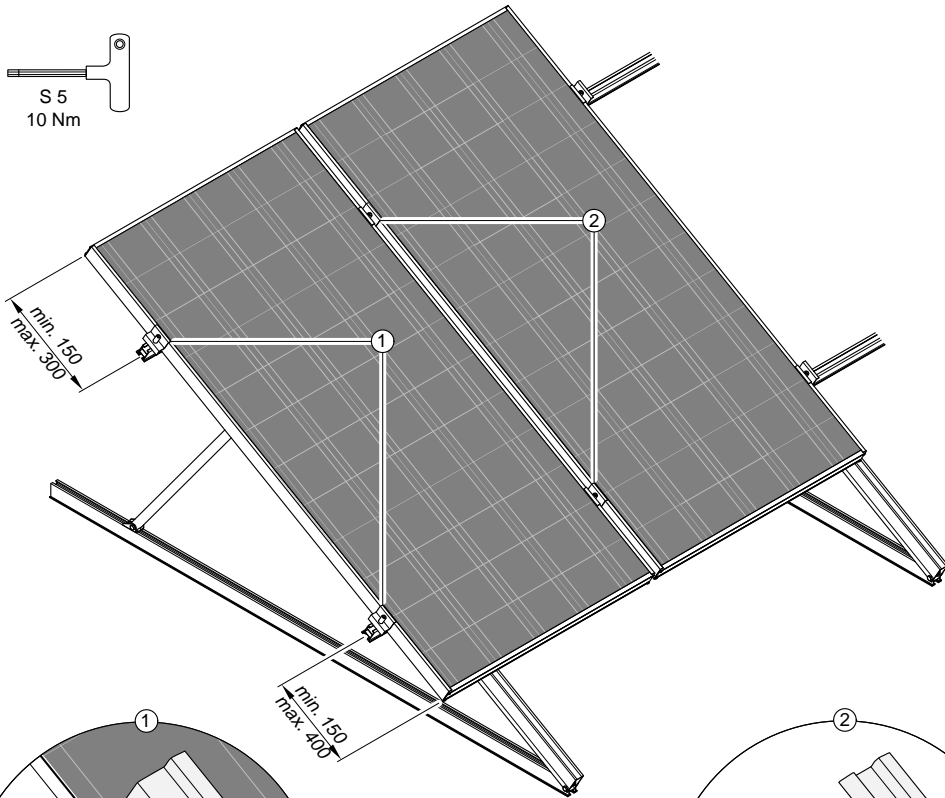
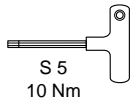

TRIC F Quer Module installation / Montaje de módulos / Montaggio moduli

