



THERMINO



THE FUTURE OF HOT WATER



IS HERE.



Discover world-leading thermal storage

Thermino® heat batteries are modern-day, energy-saving thermal stores made with a high performance phase change material to deliver mains pressure hot water reliably, safely, and more efficiently than any hot water cylinder. The sleek, super-compact design means a Thermino looks great in any home and frees up valuable storage space. They are also easy to install, kinder to the environment and require no mandatory annual maintenance.



Hot water cylinder vs Thermino



Space-saving innovation:

Up to 4 x smaller than equivalent hot water cylinders

Add solar PV at any time:

Easy and affordable upgrade to low carbon efficiency with Optimino PV key

Invigorating showers:

Enjoy the luxury of mains pressure, on-demand hot water

Hassle-free:

Easy to install, less pipework and no mandatory annual maintenance on the appliance

Super efficient:

Ultra low heat losses

Save money on fuel bills:

Charge off-peak using time of use tariffs or with free solar electricity

Legionella protection:

Innovative design protects against risk of Legionella

Hot water powered by Plentigrade®

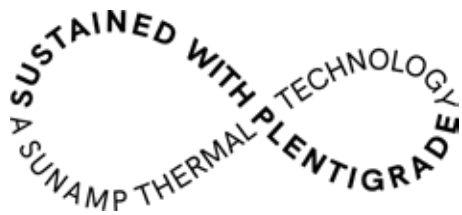

The secret to the success of Sunamp heat batteries is our world leading Plentigrade technology. The Thermino range uses high-performance Plentigrade P58 phase change material to deliver hot water on demand. It absorbs and releases thermal energy during a melting and freezing process in a similar way to the gel in a pocket handwarmer. Freezing releases a huge amount of energy in the form of heat at a constant temperature for instant, fast flowing hot water.

Our unique formula stores up to four times more energy than water, which means Thermino heat batteries are up to four times smaller than the hot water cylinders they replace. Plentigrade P58 does not contain any toxic or hazardous materials and there are no end-of-life disposal issues.

The 'Sustained with Plentigrade' quality mark on our products is assurance of performance, efficiency, safety and reliability.



Unlock the power of renewables with Optimino® technology

The Thermino range featuring Optimino technology makes it easy and affordable to transition to renewable energy. Designed to future-proof investment in Thermino heat batteries, homeowners and landlords can spread the cost of switching from fossil fuels to heat pumps and solar PV, and transition to renewables to suit their pace and budget.

First choose between the Thermino ePlus, the sleek alternative to direct hot water cylinders, or the Thermino xPlus, the space saving choice over bulky traditional indirect hot water cylinders.

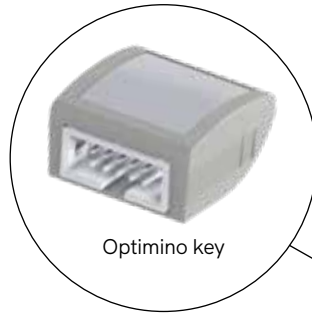

Optimino key

If adding solar PV to your system later, there's no need to buy a new heat battery. Just select the corresponding Optimino key and your Thermino will work seamlessly with your new solar setup.

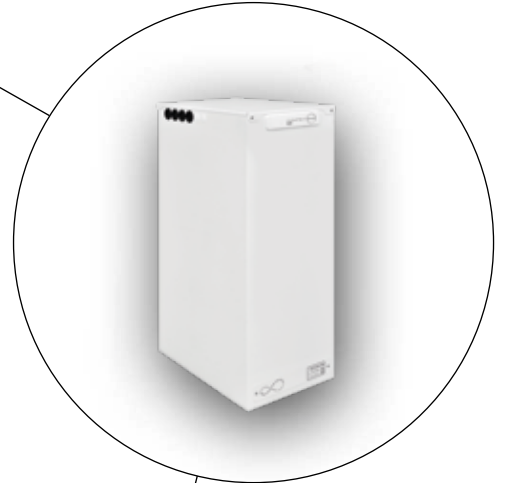

Inside Thermino

- 1 Optimino controller
- 2 Optimino key
- 3 Direct and indirect models work with a wide choice of energy sources (electricity, solar PV, heat pumps and boilers)
- 4 Simple user interface shows heat battery state of charge
- 5 Market leading 10-year warranty applies to heating element and storage core
- 6 Quick and easy to install, with high quality brass push fit connectors supplied
- 7 Flexibility of orientation, with exits on three sides of the product
- 8 High powered heat exchanger for high quality, mains pressure showers
- 9 Sunamp's patented Plentigrade P58 phase change material formulation - storing 4 x more energy than water

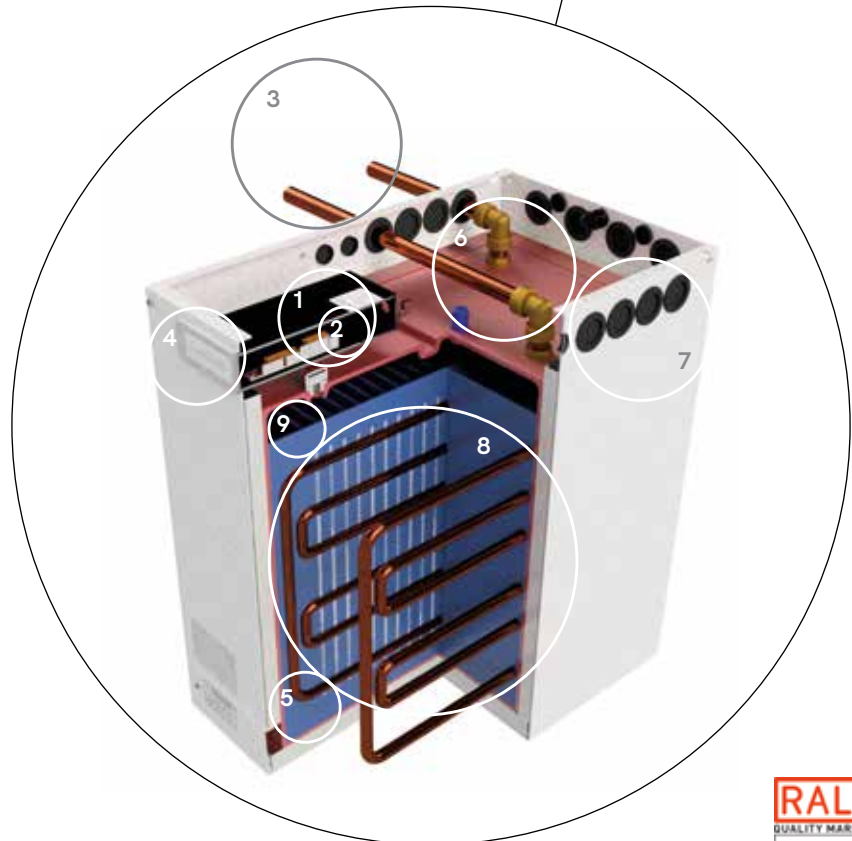

Sunamp is the only heat battery manufacturer in the world to be awarded A Grade RAL Certification, the independent quality mark and the only global standard for Phase Change Material (PCM) and PCM products. The award confirms performance with no noticeable degradation to 10,000 cycles, the equivalent of over 13 years of daily use at two cycles per day of hot water application. Sunamp's own testing has so far confirmed performance to over 40,000 cycles, comparable to over 50 years continuous use.

Transition from gas to renewables

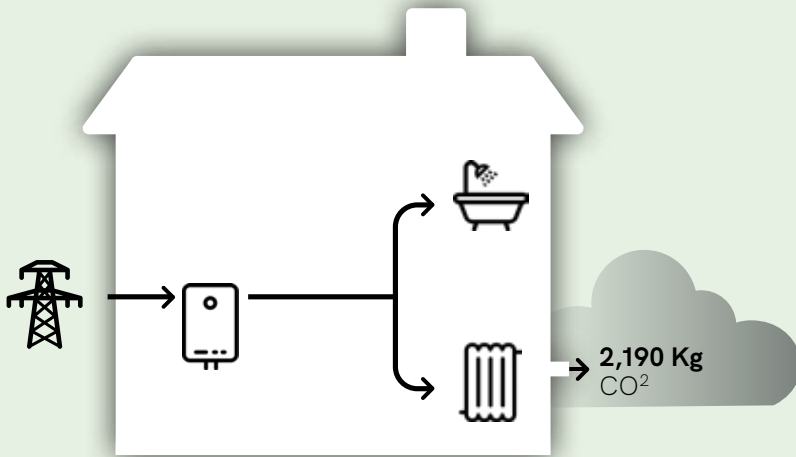

Providing mains pressure hot water, every step of the way to net zero.

Whichever heating and hot water system you're starting with, a super-compact Thermino can cut your carbon emissions, with much lower heat losses than a traditional cylinder.

If you add solar PV, an ePlus or xPlus will maximise the use of solar electricity to provide hot water. And if you go gas-free and switch to a heat pump, an xPlus will work seamlessly with this too.

Add solar PV to Thermino ePlus with Optimino PV key and benefit from surplus PV-generated electricity.

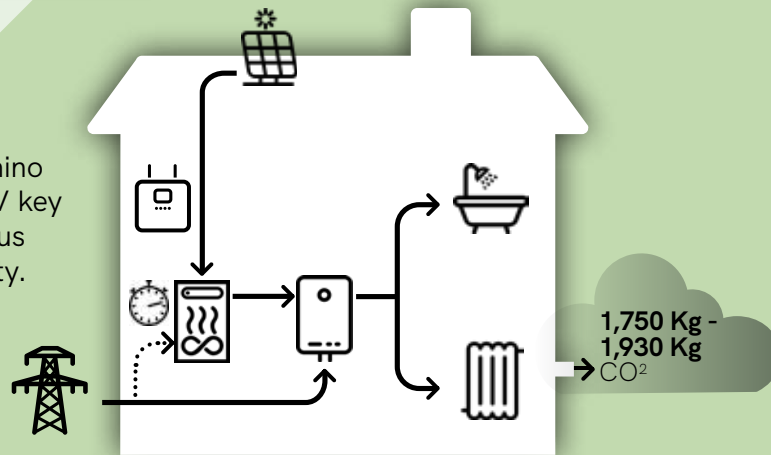

With a Thermino xPlus you can add a heat pump to complete the transition to renewables.

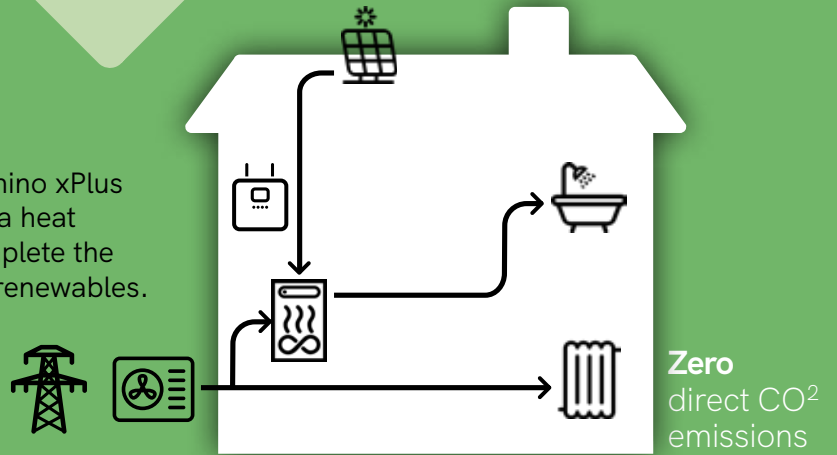

Choose your Thermino

Thermino xPlus

Thermino ePlus

	Boiler	24 hour grid supply	Off peak timer/ Variable tariff	Solar PV	Heat pump
Thermino xPlus	● with Optimino vf key	○	○	● with Optimino hpPV or vfPV key ¹	● with Optimino hp key ³
Thermino ePlus		●	○	○ with Optimino PV key ²	

● Primary energy source
○ Secondary/optional energy source

¹ See page 5 for details

² See page 7 for details

³ Choose the correct key to match your heat pump. See page 5 for details

Thermino xPlus – the small and smart alternative to indirect hot water cylinders

Energy Efficiency
Rating Class

A+



How Thermino works

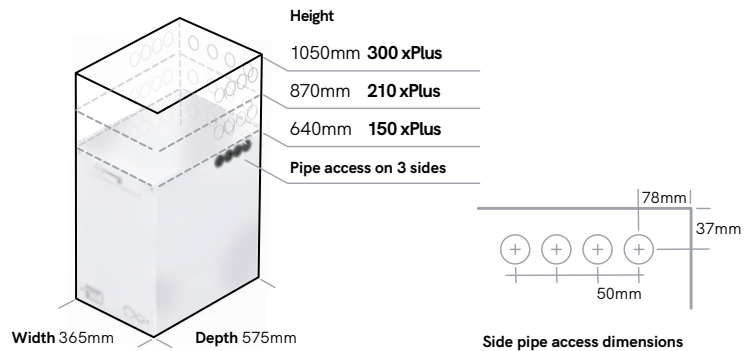
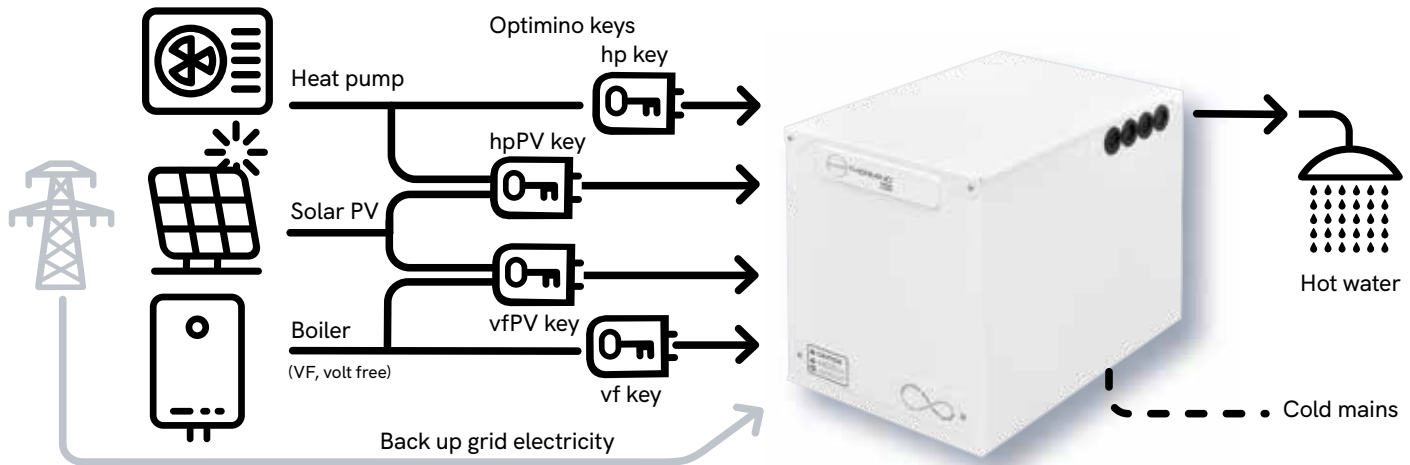

Thermino xPlus technical data	150 xPlus	210 xPlus	300 xPlus
Manufacturer's part number	DKP-KNW-AVZ-1	DNP-KNW-AVZ-1	DRP-KNW-AVZ-1
Equivalent hot water cylinder size (L)	128	192	256
V40* (L)	167	271	333
Heat loss rate (kWh/24h) (W)	0.67 (28.1)	0.77 (32.1)	0.84 (34.9)
Energy efficiency rating class	A+		
Recommended maximum flow rates (L/min)	15	20	25
Minimum mains supply pressure (bar/MPa)	1.5/0.15		
Maximum working pressure (bar/MPa)	5/0.5		
Recommended TMV temperature (°C)	45-55		
Heating element capacity at 230V, 50 Hz (W)	2,800		
Product weight in use (kg)	136	187	233

* V40 refers to the volume (in litres) of hot water available at 40°C.

NOTE: In line with UK Building Regulations, Sunamp advise the installation of a suitable hot water supply tempering valve at the outlet of the appliance, to prevent the risk of scalding.

Optimino keys

Thermino technology is **futureproof**.
Thermino xPlus can work with boilers, heat pumps and solar PV by adding the correct Optimino key.



Scan here to select the Optimino key to match your system set up



Thermino ePlus – The small and smart alternative to direct hot water cylinders



How Thermino works

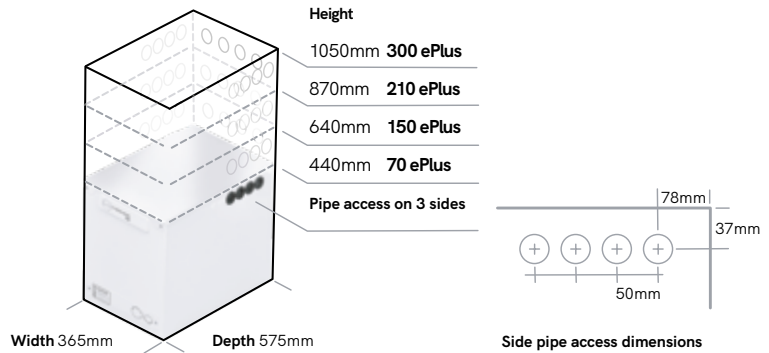
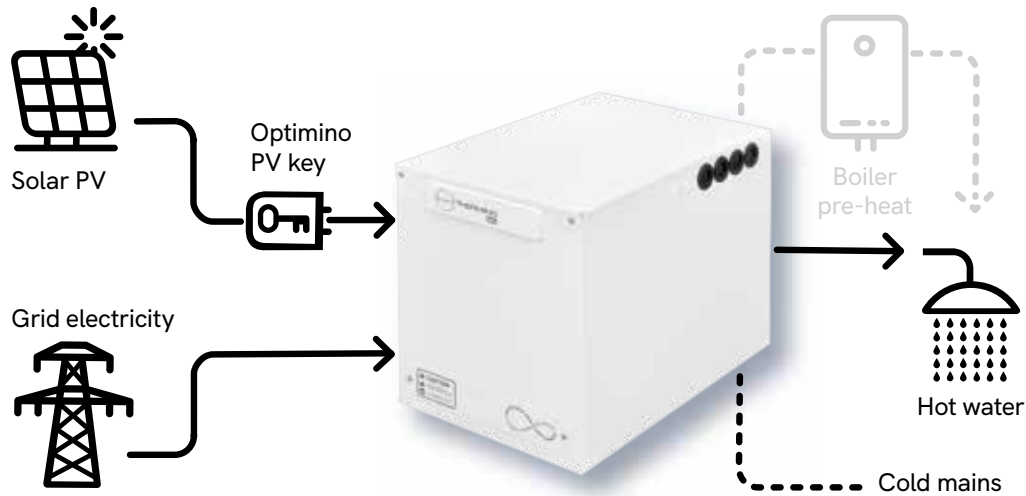

Thermino ePlus technical data	70 ePlus	150 ePlus	210 ePlus	300 ePlus
Part number	SGP-KNW-AVZ-1	SKP-KNW-AVZ-1	SNP-KNW-AVZ-1	DRP-KNW-AVY-1
Equivalent hot water cylinder size (L)	74	140	212	306
V40* (L)	105	199	301	436
Heat loss rate (kWh/24h) (W)	0.48 (20)	0.67 (28.1)	0.77 (32.1)	0.84 (34.9)
Energy efficiency rating class	C			
Recommended maximum flow rates (L/min)	6	15	20	25
Minimum mains supply pressure (bar/MPa)	1.5 /0.15			
Maximum working pressure (bar/MPa)	5/0.5			
Recommended TMV temperature (°C)	45-55			
Heating element capacity at 230V, 50 Hz (W)	2,800			
Annual electricity consumption (kWh/annum)	542	1,398	2,690	2,701
Product weight in use (kg)	79	140	178	233

* V40 refers to the volume (in litres) of hot water available at 40°C.

NOTE: In line with UK Building Regulations, Sunamp advise the installation of a suitable hot water supply tempering valve at the outlet of the appliance, to prevent the risk of scalding.

Optimino PV key

Thermino technology is **futureproof**.
When you want to use solar PV
simply add the Optimino PV02 key



Scan here for more information
and details of compatible solar
power diverters





Installation and technical support

Where can I buy Sunamp products?

Sunamp products are available through our network of distributors. Any direct sales enquiries are forwarded to our installer and distributor network and our products are available through our approved stockists.

Scan here for our current list of distributors and installers.



Sunamp heat batteries are world-leading, high-energy density, super-compact thermal stores. For best performance and peace of mind, it is important to ensure that they are correctly specified and expertly installed.

All Sunamp certified installers receive free training and ongoing technical support to ensure they have the knowledge and skills to provide the best solution for their customers. Training is available online and in person at the Sunamp factory where we have a state-of-the-art facility designed especially for these sessions.

Technical manuals can be downloaded at sunamp.com

Sales enquiries

Project specifiers, housing developers and social landlords interested to find out how Sunamp can help you on your road to net zero, please email sales@sunamp.com

How do I become a Sunamp certified installer?

We run regular training sessions. To find out if you qualify for our free training packages simply email training@sunamp.com



Sunamp and sustainability

Reducing carbon footprint to achieve a net zero economy is at the heart of everything we do as a business.

We have signed up to the SME Climate Hub commitment to halve our greenhouse gases by 2030 and achieve net zero emissions before 2050. Recent analysis shows the greenhouse gas intensity per sold product associated with our direct business activities is already approximately zero.

Our Thermino heat batteries are non-toxic, non-flammable and we are able to fully re-use or recycle every component at end-of-life. They are produced in a factory and offices heated and powered by carbon-free electricity from wind generation. We have carbon accounting systems in place to collect relevant data and report on our emissions reduction progress annually.

Customer support

If you would like more detailed information on our products or have a technical enquiry please contact **customerservice@sunamp.com**

Please include all details of your enquiry and relevant warranty information. We will respond to all enquiries in a clear and friendly manner within one working day.

*Sunamp has protected their technology in a wide range of global patents based on the patent applications listed on our website **sunamp.com***

All trademarks featured in this brochure are owned, registered, or used under licence by Sunamp Limited.

Quality Assured

We work to the highest of standards and hold ISO accreditation having achieved key international and UK quality certifications which underline our commitment to sustainability, health and safety, and quality in everything that we do.

ISO 9001 – Quality Management
ISO 14001 – Environmental Management
ISO 45001 – Occupational Health & Safety



Certificate number 12881

Sunamp products are also fully certified for the UK and European markets, are fully compliant with the low voltage directive (LVD) and electromagnetic compatibility (EMC) directive, conform to standards set out by the UK water regulations and are CE marked.



Sunamp is an industrial associate of:



Sunamp technology developed in association with:



THE UNIVERSITY
of EDINBURGH



EDINBURGH
INNOVATIONS

As an innovative company committed to achieving net zero, Sunamp Ltd continuously improves its products which means data and other information are subject to change without prior notice. While every effort has been made to ensure that all specifications and descriptions are correct at the time of going to press, this brochure should not be regarded as an infallible guide nor as an offer of sale for a particular product.

Always refer to the latest version of this document, other information and our latest terms and conditions which are available to view and download at www.sunamp.com