



Keep these instructions in a safe place for future reference









Thermino® hp(-DN & -SG) Heat Batteries Installation and User Manual



Safety Notice

Symbols and Notices Used and Their Meanings

Symbols			
			
Warning	Electric Hazard	Take note	Cross reference
Warning Notices	Consequences	Likelihood	
 WARNING	Death/serious injury (irreversible)	Potential risk	
 CAUTION	Damage/minor injury (reversible)	Potential risk	



DO NOT install outdoors. This product is for indoor use only.

Improper installation, adjustment, alteration, service or maintenance can cause property damage, injury and death.

ONLY competent persons who are suitably qualified to carry out plumbing and electrical work and have successfully completed product training by Sunamp Ltd or an authorised training partner may undertake installations, repairs or relocations.

The system must be earthed correctly and have its own independent electrical supply with correct voltage and circuit breakers.

The point of connection to the mains should be readily accessible and adjacent to the Heat Battery installation. Connection must allow isolation of the electrical supply. Disconnection must be achieved in accordance with the wiring rules.

Only use this product for the intended purpose described in this manual.

There are no user serviceable, adjustable or settable parts in this product.

Read the full Safety Instructions in Section 1 of this manual before you install this product.



Document Purpose

To instruct competent persons on how to safely install **Thermino®150 hp(-DN & -SG) & 210 hp(-DN & -SG) & 300 hp(-DN & -SG) Heat Batteries**. Competent persons are those suitably qualified to carry out plumbing and electrical work. Product training on the full range of Thermino Heat Batteries by Sunamp Ltd or an authorised training partner is available.

Contents

1	Safety Instructions	4
1.1	Intended Use.....	4
1.2	Pre-installation Safety Advice	4
1.3	Mechanical Safety.....	4
1.4	Electrical Safety.....	5
1.5	Water Safety.....	6
1.6	User Competence, Qualification, and Approval	6
1.7	Compliance with Safety Laws and Regulations.....	7
1.8	Post-Installation Safety.....	7
1.9	Repair and Relocation.....	8
2	Thermino hp(-DN & -SG) Heat Battery Overview	9
2.1	Introduction.....	9
2.2	Product Overview.....	10
2.3	Product Identification.....	12
2.4	Accessories and Parts.....	14
2.5	Technical Specifications	15
2.6	Pressure Loss Characteristics	18
2.7	Product Compatibility.....	20
3	Installation	21
3.1	Installation Process	21
3.2	Water Supply Requirements	25
3.3	Location and Space Requirements.....	26
3.4	Hydraulic Requirements	27
3.5	Temperature and Insulation Requirements	28
3.6	Electrical and Wiring Requirements	28
3.7	Wiring Option 1 - Thermino hp-SG Low Temperature Heat Pump	32
3.8	Wiring Option 2 - Thermino hp-DN Low Temperature Heat Pump.....	36
4	Commissioning	40
4.1	Preparation.....	40
4.2	Process.....	40
4.3	Heat pump settings	41
5	Operation	43
5.1	Switch On/Off.....	43
5.2	LED Indicators and Status.....	43
5.3	Troubleshooting.....	44
6	Maintenance	46
6.1	Removal of Lids.....	46
6.2	Cleaning	46
6.3	Warranty	47
7	Recycling and Disposal	47



1 Safety Instructions



Sunamp Ltd is not responsible for the failure of components not specified in this manual and/or supplied by other manufacturers.

1.1 Intended Use

The intended use of the **Thermino hp(-DN & -SG)** range of products is for the provision of hot water for domestic purposes by means of using a low temperature heat pump as a main heat source. The heat battery can also be electrically charged when receiving a boost signal from the Low Temperature Heat Pump. Its internal element will also operate as an automatic backup if the heat pump is not able to deliver a satisfactory high temperature to charge the heat batteries (Note: Only if Link 3 is present (Factory Setting)).

This range of products is **NOT** intended for direct connection of the heat batteries with PV systems.

1.2 Pre-installation Safety Advice

- Sunamp Ltd is not responsible for the selection, specification or effectiveness of equipment, unless stated in writing. Responsibility lies with customers and any experts or consultants involved in design and/or installation.
- Where applicable, this manual should be read in conjunction with manufacturer documentation for any components specified in the installation requirements of this manual.
- Where necessary, refer to the Sunamp website (www.sunamp.com) for contact and support information.

1.3 Mechanical Safety

⚠ WARNING

- DO NOT install outdoors. This product is only suitable for installations indoors in a frost-free environment, to avoid weather damage.



- DO NOT tilt the product more than **45 degrees** during the transportation or installation process.
- Install the product on a **hard, solid and level surface** that can support its weight.
- DO NOT use **detachable hose-sets** to connect the system to water mains.
- All hot works (such as soldering, welding or brazing) must be performed on tubes detached from the heat battery (minimum 1 metre away).
- This product is NOT suitable for tank fed hot water system.
- DO NOT immerse this product in water or any other liquid.
- DO NOT under any circumstances open any of the ports on the red cell. Doing so can lead to PCM leakage and irreparable damage to the heat battery. Opening the red cell will void the warranty of the product.
- DO NOT insert any third-party tank sensor or any other instrumentation into the heat battery.
- DO NOT use any sharp objects in proximity of the Vacuum Insulation located at the side of the Heat battery.
- DO NOT stack Heat Batteries with internal controller directly on top of each other, if using multiple Heat Batteries.

1.4 Electrical Safety

⚠ WARNING

- The product must be earthed correctly and have its own independent electrical supply (with correct voltage and circuit breakers).
- The point of connection to the mains should be readily accessible and adjacent to the Heat Battery installation.



- Connection must allow isolation of the electrical supply. The means of isolation must be accessible to the end user after installation.
- All electrical wiring should be carried out by a competent person and be in accordance with the latest IET Wiring Regulations.
- Each circuit must be protected by a suitable fuse and double pole isolating switch with a contact separation of at least 3mm in both poles.
- Ensure that there is water in the appliance before switching on electrical supply.
- All models in this manual are designed for heating by using a Low Temperature Heat Pump and as a backup by using an integrated electric heater.

1.5 Water Safety

⚠WARNING

- Minimum working pressure of Heat Battery is **0.15 MPa / 1.5 Bar**. Maximum working pressure of Heat Battery is **1.0 MPa / 10 Bar**. See section 2.5.2 for detailed specifications.

1.6 User Competence, Qualification, and Approval

⚠WARNING

- ONLY competent persons who are suitably qualified to carry out plumbing and electrical work, may undertake installations, repairs or relocations. Product training on the full range of Thermino Heat Batteries by Sunamp Ltd or an authorised training partner is available.
- DO NOT allow children or any other unqualified or unapproved persons to install, repair, clean, relocate, interfere or tamper with the product.



- This product is not designed for use by children, or persons with reduced physical, sensory or mental capabilities, and should not be used by such persons unless they can do so safely. Where necessary, such persons (or anyone with lack of experience or knowledge) should first be given supervision or instruction concerning use of the product by a person responsible for their safety.

1.7 Compliance with Safety Laws and Regulations

⚠ CAUTION

- Installations, repairs and relocations must comply with all relevant local laws and regulations ('statutory obligations'), particularly concerning electrics, water supplies, building regulations and Manual Handling Operations, as issued by the Government *Health and Safety Executive* ('HSE'). Water distribution and central heating installations ('systems') must comply with all statutory obligations.
- Statutory obligations always override manufacturer documentation where there is a conflict.

1.8 Post-Installation Safety

- All goods are sold subject to Sunamp Ltd's 'Conditions of Sale', as listed on our website.
- As Sunamp Ltd continuously improves products, they may be modified without notice. In such circumstances this manual and other relevant documentation should be disregarded. Updated documentation will be produced, supplied with new product ranges and made available on request.
- Once installed:
 - Perform a test run to ensure normal operation.



- Explain all safety precautions to the end user.
- Provide a copy of this manual to the end user.
- It is the responsibility of the end user to supply this manual to any other subsequent users.

1.9 Repair and Relocation

⚠WARNING

- DO NOT attempt to carry out repairs or maintenance before the system components – including the **Thermino hp(-DN & -SG) Heat Batteries** - have cooled down to ambient room temperature. To speed up the process, disconnect power supply and open hot water taps in the dwelling to draw off hot water and cool system down.
- DO NOT attempt to move an assembled system without using appropriate lifting equipment.
- There are no user serviceable, adjustable or settable parts in this product.

**SAVE THESE INSTRUCTIONS AND
PROVIDE A COPY TO THE END USER.**



2 Thermino hp(-DN & -SG) Heat Battery Overview

2.1 Introduction

Thank you for choosing a Sunamp Ltd **Thermino** Heat Battery, our innovative, super-compact heat storage systems based on Plentigrade® phase-change materials (PCM). We are sure you will be delighted with the performance, compactness, ease of installation and quality of our product.

Sunamp Ltd's decade-long history of research and innovation in PCM technology has made it the world-leading manufacturer in Heat Battery technology – developed, designed and manufactured in the UK.

Sunamp Ltd has a wide portfolio of Heat Batteries for different applications. Please visit our website (www.sunamp.com) or look at our catalogue for more information about our portfolio for:

- Water heating
- Space-heating
- Combined space- and water-heating
- Cooling

The Sunamp Ltd **Thermino hp(-DN & -SG)** Heat Batteries are:

- Designed to produce domestic hot water heating by using a Low Temperature Heat Pump as a main source of heat, the range of heat batteries have a standby heating element built in to act as a backup if the main heat source fails.
- Equivalent to indirectly heated hot water cylinders and hot water only thermal stores.
- Able to replace indirect vented and unvented hot water cylinders for heat pumps.
- Classified as a *Primary* Thermal store. By transferring heat from the PCM to the mains water flowing through the heat exchanger, they produce hot water instantaneously and on demand.
- Class I stationary appliances that use a single-phase electrical supply.



See the [downloads section](http://www.sunamp.com) of our website (www.sunamp.com) for other useful information on Sunamp Ltd. products.

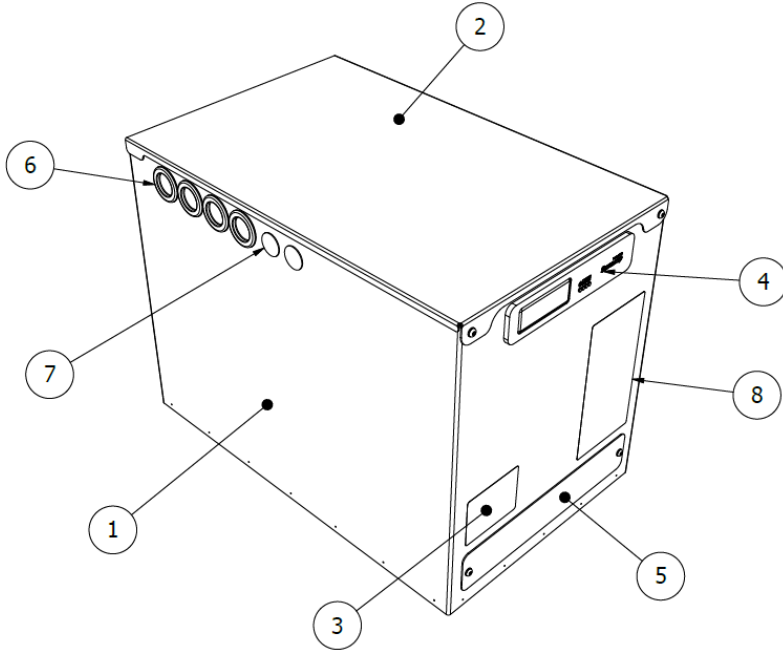

2.2 Product Overview

Figure 1: Heat Battery (external)

Item	Description
1	Heat Battery - main body
2	Heat Battery - lid
3	Data badge / serial number
4	Controller interface
5	Terminal cover plate
6	Tube entries (3 sides)

7	Cable entries (3 sides)
8	Energy label - to be applied by installer (if applicable)

Table 1: Product overview (external)

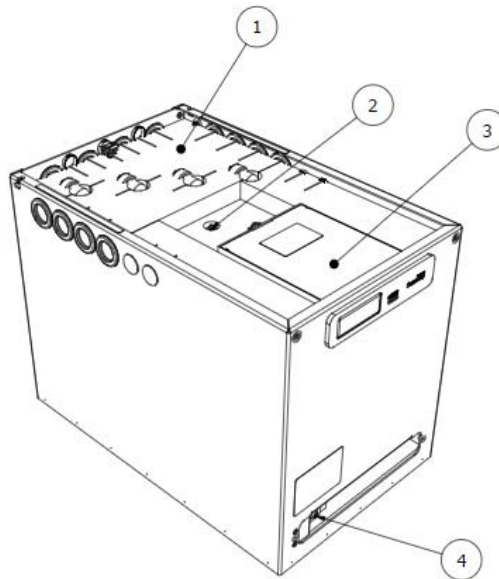

Figure 2: Heat Battery (internal)

Item	Description
1	Insulation layers - to be cut to suit copper tube and cable entries
2	Temperature sensor
3	Electrical control box - PCB, relays, terminal block
4	Non-self-resetting overhear thermostat (OHT)

Table 2: Product overview (internal)

2.3 Product Identification

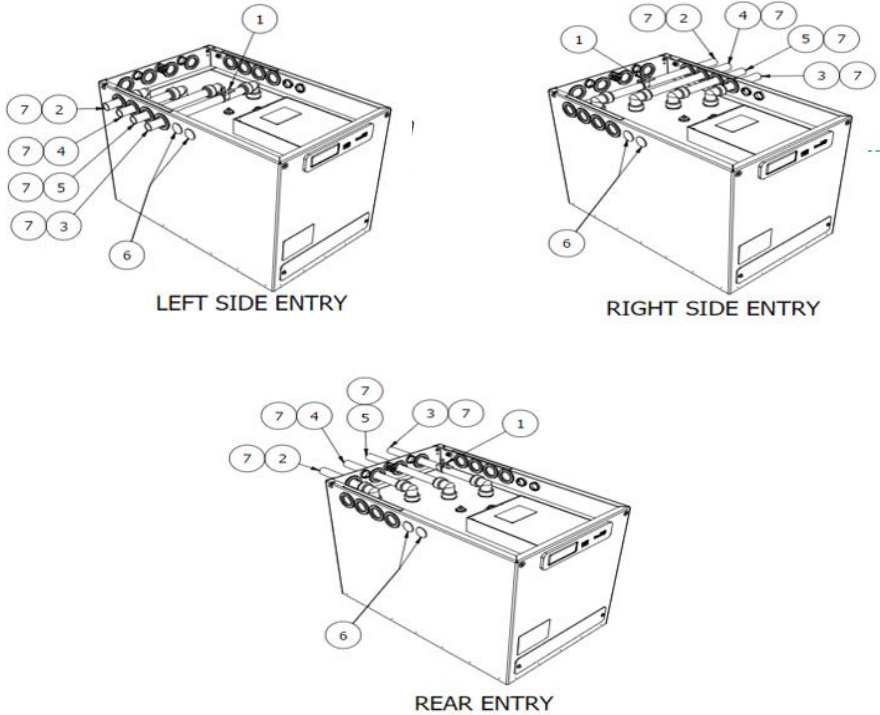

Figure 3: Heat Battery views showing the three tube exits

Item	Description	Item	Description
1	Earth Clamp (supplied) - to be clamped to Ø22mm copper tube	5	Heat Pump Flow - "C" - Ø22mm elbow - rotatable 360 degrees
2	Cold Water Inlet - "A" - Ø22mm elbow - rotatable 360 degree	6	Cable Entry via Gland - supplied but not fitted
3	Hot Water Outlet - "D" - Ø22mm elbow - rotatable 360 degrees	7	Ø22mm Copper Tube to BSEN1057 - suitable for installation (not supplied).
4	Heat Pump Return - "B" - Ø22mm elbow - rotatable 360 degrees	 Tube and cable entries are used depending on installation location	

Table 3: Product installation options

2.3.1 LED Interface

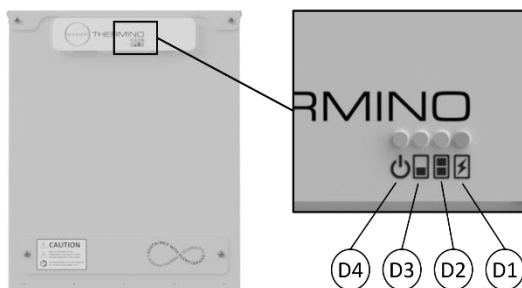

Figure 4: LED interface

Item	Description
D4	Mains power LED
D3	Charge level status LED
D2	Charge level status LED
D1	Heater 'Active' LED

Table 4: LED interface

2.4 Accessories and Parts

Part Number	Description
C5388	Tempering Valve
C5407	Expansion Vessel 0.5L
C5381	Water conditioner
C5377*	22mm Tectite Pro Elbow TX12 65524
C5379	22mm Tectite Pro Tee TX24 65676
C5412*	Conex BM8090 0220000 22mm >B< Push elbow
A1135	Daikin Low Temperature Heat Pump Connection Kit Consisting of: <ul style="list-style-type: none"> - C2291 - Relay Interface, Easy Relay 240VAC - C2292 - Back box - C2293 - Daikin X13A connector Booster cable - C2294 - Daikin X9A connector Tank sensor cable - C2295 - 2 Core 0.5mm² Cable - C2296 - M12 Cable gland (x2)
A1136	Samsung Low Temperature Heat Pump Connection Kit Consisting of: <ul style="list-style-type: none"> - C2291 - Relay Interface, Easy Relay 240VAC - C2292 - Back box - C2295 - 2 Core 0.5mm² Cable - C2296 - M12 Cable gland (x2)

Table 5: Accessories.

* 4 x C5377 or C5412 and A1135 or A1136 are supplied with the product as standard.



Visit our website (www.sunamp.com) for all the latest accessories and spare parts.

2.5 Technical Specifications

2.5.1 Basic Specifications

Battery Model	Height (mm)	Depth (mm)	Length (mm)	Gross Weight (kg)	Net Weight (kg)
Thermino 150 hp(-DN&-SG)	640	365	575	136	129
Thermino 210 hp(-DN&-SG)	870			187	176
Thermino 300 hp(-DN&-SG)	1050			233	220

Table 6: Thermino hp(-DN & -SG) Heat Battery models. **Net Weight** refers to an **empty Heat Battery** (i.e. no water in the tubes); **Gross Weight** refers to being filled with water.

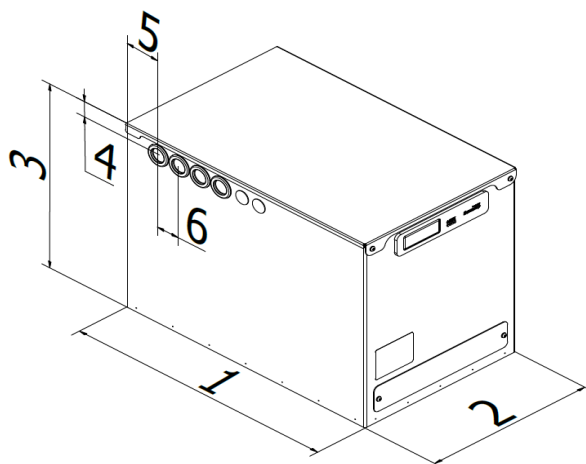

Figure 5: Additional Sunamp Ltd **Thermino hp(-DN & -SG)** Heat Battery dimensions

Item	Description	Item	Dimensions
1	Length: See Table 6	4	Tube Entry: 37mm
2	Depth: See Table 6	5	Tube Entry: 78mm
3	Height: See Table 6	6	Tube Entry: 50mm

Table 7: Additional product dimensions



2.5.2 Detailed Specifications

Specification		Thermino 150 hp(-DN & -SG)	Thermino 210 hp(-DN & -SG)	Thermino 300 hp(-DN & -SG)	See Note
Water Content (L)	Primary circuit	3.7	5.3	6.4	1
	Secondary circuit	3.7	5.3	6.4	
Equivalent Hot Water Cylinder Size (L)		128	192	256	2
V_{40} , Volume of Hot water available at 40°C (L)		167	271	333	3
Standby heat loss rate (kWh / 24h (W))		0.67 / (28.1)	0.77 / (32.1)	0.84 / (34.9)	
ErP Rating class		A+			5
Recommended maximum HW flow rate (L/Min)		15	20	25	
Minimum heat source flow temperature (°C)		65			6
Maximum heat source flow temperature (°C)		80			7
Minimum mains supply pressure at inlet of Heat Battery (MPa / (Bar))		0.15 / (1.5)			
Maximum working pressure (MPa / (Bar))		1.0 (10)			
Pressure loss characteristics K_v Values		Figure 6.1 & 6.2 (Section 2.6)			
Hot water outlet temperature at design flow rate (°C)		45-55			4
Back-up Heater - Connected load at ~ 230 V, 50Hz (W)		2,800			
Power supply / Standby consumption (W)		1 PH ~ 230 V / 7			

Table 8: Detailed specifications for **Thermino hp(-DN & -SG)** Heat Battery models



Notes to Table 8:

1. Water content of the Heat Battery for sizing expansion vessels.
2. Calculated from the storage capacity of the Heat Battery and assuming that the equivalent hot water cylinder thermostat is set at 60°C, mains cold water inlet temperature is at 10°C and the stored energy utilisation factor of the cylinder is 0.85.
3. The hot water volume available from the Heat Battery normalised to an average outlet temperature of 40°C when it is fully charged.
4. Recommended setting range for hot water tempering valve.
5. When heated by an Low Temperature Heat Pump.
6. Minimum constant heat source flow temperature from a Low Temperature Heat Pump for charging the Heat Battery.
7. Low Temperature Heat Pump flow temperature should not exceed this value when the Heat Battery is being charged.



For more detailed specifications, also see the **Thermino Heat Batteries General Product Application and Design Manual**, available from the [downloads section](#) of our website (www.sunamp.com).

2.6 Pressure Loss Characteristics

The primary circuit of the heat battery is connected to the heat pump flow and return as shown schematically in (Figure 6.3). The primary circuit design flow rate will depend upon the thermal rating of the heat pump and the design temperature difference. For a typical system, the primary flow rates are given in (Table 9), Primary flow rate in the heat battery charging circuit should be set to give around 7°C temperature difference to minimise flow rates.

Thermal output of the heat pump (kW)	4.0	6.0	8.0	10.0
Primary flow rate at 7.5°C design temperature difference (l/min)	7.6	11.6	15.2	19.2

Table 9: Thermino hp(-DN & -SG) Heat Battery Primary circuit flow rate

The corresponding values for the pressure loss through the primary heat pump circuit can be read in (Figure 6.1).

The secondary circuit of the heat battery is connected to dwelling hot water circuit as shown schematically in (Figure 6.2). The pressure loss values can be read in (Figure 6.1).

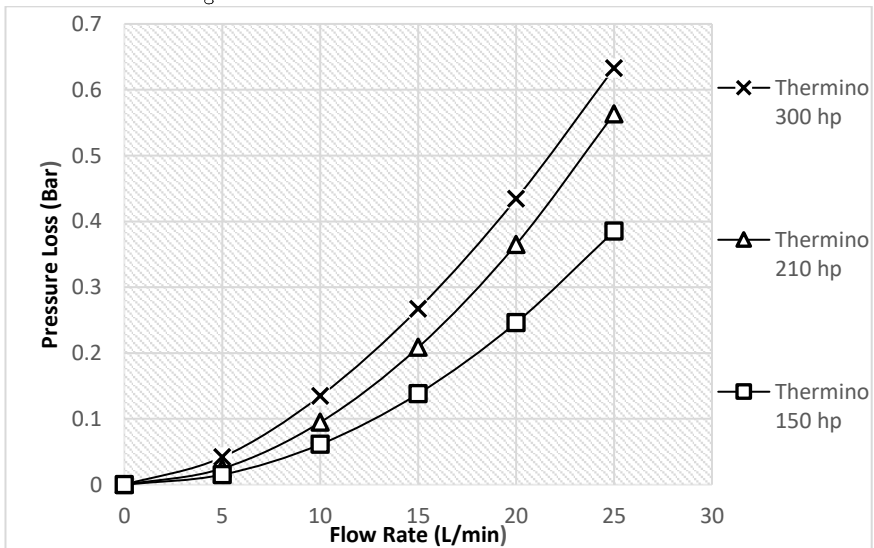

Figure 6.1: *Thermino hp(-DN & -SG) Heat Battery Primary circuit pressure loss characteristics graph*

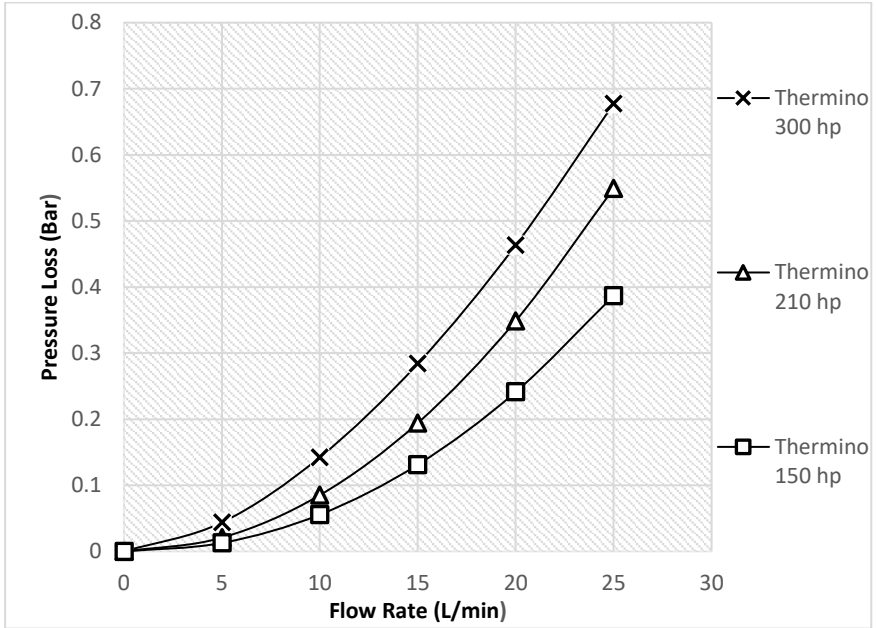

Figure 6.2: *Thermino hp(-DN & -SG) Heat Battery Secondary circuit pressure loss characteristics graph*

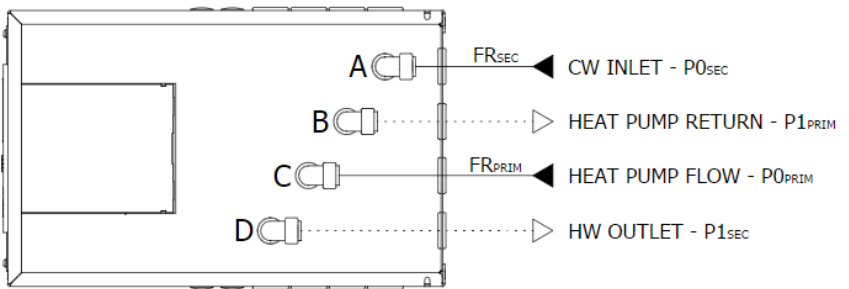

Figure 6.3: *Pressure loss at inlet & outlet of the Heat Battery*



2.7 Product Compatibility

For the correct operation of the Sunamp heat batteries with the Samsung and Daikin Low Temperature heat pumps, please ensure that the correct combination displayed in (Table 10) below is used.

		Thermino hp(-DN & -SG) Heat Battery		
		Thermino 150 hp	Thermino 210 hp	Thermino 300 hp
Samsung Heat Pumps	AE050RXYDEG/EU + MIM-E03CN	✓	✓	✓
	AE080RXYDEG/EU + MIM-E03CN	✓	✓	✓
	AE120RXYDEG/EU + MIM-E03CN	*		
Daikin Heat Pumps	ERGA04DVA + EHBH04D6V	✓	✓	✓
	ERGA06DVA + EHBH08D6V	✓	✓	✓
	ERGA08DVA + EHBH08D6V	✓	✓	*

Table 10: Sunamp Heat Battery, Samsung & Daikin Heat pump product compatibility

*Contact Sunamp for further information

3 Installation



Always read the safety instructions in Section 1 of the manual before installing **Thermino hp(-DN & -SG)** Heat Batteries.

3.1 Installation Process

Preparation:

- Assess the location of installation considering spatial requirements, clearances, cable runs and tube runs.
- Unpack and discard or recycle packaging according to local disposal or recycling rules.
- Identify which side you wish to make hydraulic and electrical cable entries (see Figure 3 in Section 2.3).
- Prepare the system hydraulics and electrics.
- Lift unit into position using appropriate lifting methods.

Hydraulic Connection:



Note: The mains cold water inlet connects to port A; Hot water outlet connects to port D. Meanwhile the LTHP flow pipe connects to Port C and the LTHP return pipe connects to Port B (Figure 6.3).

- Remove lid. The lid is secured by 2 x M5 button head cap screws at the front and two locating pins at the back (Figure 7):
 - Remove 2 x M5 button head cap screws using 3mm hex head and set aside.
 - Slide the lid forward, then lift the lid up and set aside.
- Remove the top two layers of insulation (layer 1 is 10mm and layer 2 is 32mm thick) and set aside.
- Rotate the elbows to the side you wish to connect the hydraulics (left, right or back).
- Remove the respective rubber grommets in the outer housing and cut the centres (with a cross) with a knife. Re-insert the cut grommets.
- Cut and prepare the two off lengths of Ø22mm copper tube to suit the rest of the installation / system:



- Always cut the tube square, using a rotary tube cutter whenever possible. Ensure the cutter wheel is appropriate for the copper tube.
 - Deburr the tube end, both internally and externally to create a 1mm chamfer on the outside of the tube.
 - Check the tube ends are free from damage and clean, wiping away any swarf to avoid damaging the 'O' ring on tube insertion.
 - Tube end must also be free from stickers, tape and adhesive residues.
 - Mark the socket depth (27mm) on the tube with a marker.
 - Insert the tube firmly with a slight twisting action until it reaches the tube stop with a positive "click".
 - Ensure the depth insertion mark corresponds with the mouth of the fitting, then pull firmly on the tube to ensure the fitting is secure.
- Fit the earth clamp to the Ø22mm copper tube (See Figure 3 in Section 2.3).
 - Connect to the rest of the fixed system hydraulics.
 - Fill the system with water, purging any air out of the system. This may take several minutes and can be aided by repeatedly opening and closing the outlet.
 - Once finished purging and with the system pressurised, inspect the piping/tubing and joints for any leaks. Take remedial action if necessary.



Electrical Connections:

- Move the cable strain relief fittings to the side you wish to make the entries / exits. Cover all other holes in the enclosure with the supplied blanking grommets. (Figure 8).
- Feed the mains cable through the strain relief bushing in the heat battery housing.
- Feed the heat pump signal (section 3.7.2 & 3.8.2) & booster signal cables (section 3.7.1 & 3.8.1) through the additional strain relief fittings.

- Line up the cable strain relief fitting ratchet feature and compress firmly so that the fitting grips the cable.
- Open the internal controller enclosure using a flat head screwdriver to remove the snap in' lid.
- Connect the wires according to the wiring options if not already fitted.
- Remove or make links according to the wiring options.
- Close up the internal controller enclosure replacing the 'snap fit' lid and check the earth clamp on the copper tube is secure.

Final Fit After Commissioning:



Commissioning instructions are provided in Section 4 of this manual. Follow the instructions below after commissioning.

- Cut the 32mm thick insulation layer to suit the tube and cable entries. This layer has several perforations for guidance. This can be done with a sharp knife or scissors.
- Replace the newly cut 32mm thick insulation layer nesting the insulation around the tube work and cables. Makes sure the mains and signal cables sit above this layer.
- Replace the top layer 10mm layer of insulation.
- Replace the lid, aligning the rear pins with the slots in the rear of the unit, slide back, fit the 2 x M5 button head capscrews using 3mm hex head.

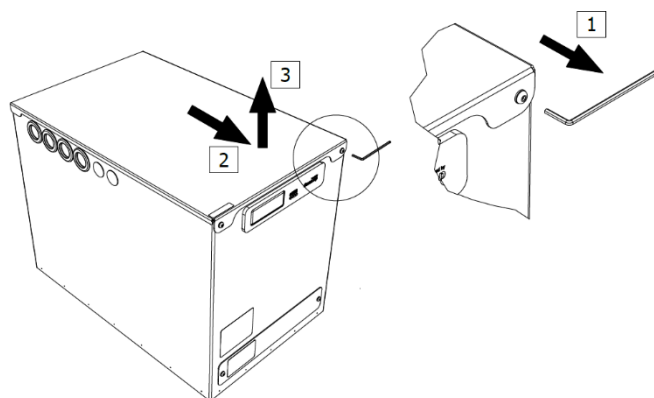

Figure 7: Access to Heat Battery connections

Item	Description
1	Remove fasteners x2 using 3mm Allen Key
2	Slide lid forward
3	Lift lid

Table 11: Access to Heat Battery connections

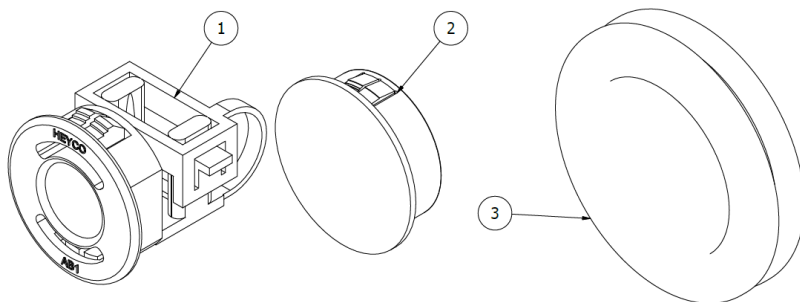

Figure 8: Cable and tube interfaces

Item	Description
1	Cable entry strain relief gland
2	Cable entry blanking bush
3	Tube entry grommet

Table 12: Cable and tube interfaces

3.2 Water Supply Requirements



Important: All components fitted in the water system should be *Water Regulations Advisory Scheme (WRAS)* approved.

3.2.1 General



For information regarding expansion vessel sizing and pressure relief valves, refer to the information provided on the product data label regarding water content and industry guidance.



Important: Although the Heat Batteries are designed for **1.0MPa (10 bar)** maximum working pressure, it is recommended that if the incoming mains pressure is greater than **0.5MPa (5 bar)**, a WRAS approved pressure regulator set at 0.5MPa (5 bar) should be fitted.

- Mains cold water supply should be connected to Heat Battery connection 'A'. The hot water outlet should be connected to 'D'. Heat Pump Flow should be connected to Heat Battery connection 'C' and Heat Pump Return should be connected to Heat Battery connection 'B'. (see Figures 6.3, 12.1 and 13.1).
- DO NOT use detachable hose-sets to connect the product to the water mains.
- Minimum - Maximum dynamic mains water supply pressure: **0.15MPa (1.5bar) - 1.0MPa (10 bar)**.
- Minimum mains cold and hot water tube sizes: **Ø22mm copper or equivalent**.
- Expansion vessel charge pressure = Incoming mains pressure (MPa).
- A potable water expansion relief valve **MUST** be fitted, unless it has been established that the water is able to expand back into the mains. In case of doubt over the presence of non-return valves in the system, a potable water expansion relief valve should be fitted as a precaution.
 - The valve should be fitted in compliance with Building Regulations Approved Document G.
 - The valve should be chosen based upon the mains water pressure, with a maximum allowable rating of **1MPa (10 bar)**.
- The heat pump circuit (closed circuit) must be fitted with an expansion relief valve.
- A WRAS approved hot water tempering valve should be fitted at the outlet from the heat battery. The tempering valve should be set to

deliver hot water between 45°C and 55°C depending on the installation requirements.

3.2.2 Hard Water and Limescale



Where mains water hardness can exceed **150 ppm Total Hardness**, you must install a scale reducing device in the cold-water supply to the Heat Batteries.

Limescale can be controlled using: chemical limescale inhibitors, polyphosphate dosing, electrolytic scale reducers or water softeners.

3.3 Location and Space Requirements

- The Heat Battery is suitable for indoor use only.
- Avoid locations in close proximity to other building services, hot works, and other sources of heat. Hot works, such as soldering, welding or brazing must **ONLY** be undertaken a **minimum distance of 1m from the system** and by using cooling clips or other heat absorbent materials.
- Due to the weight of the Heat Battery, ensure the floor is level, sound and capable of supporting its weight (Table 6).
- Allow for space of 150mm around the Heat battery (i.e. to view LED lights), and space of 450mm above it (i.e. to remove the lid if necessary):

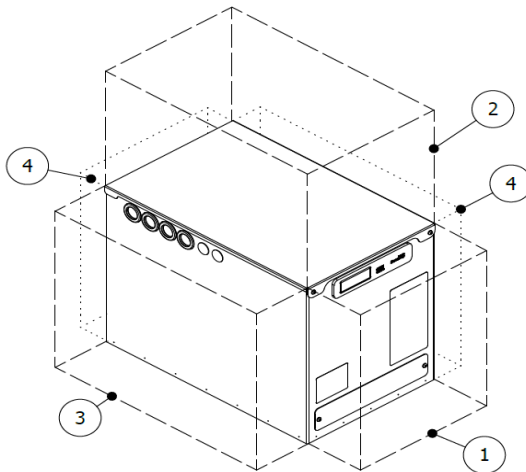

Figure 9: Spacing (in mm) surrounding the Sunamp Ltd. Heat Battery

Item	Space	Reason
1	150mm	To access terminal cover and to ensure visibility of the data badge and LEDs
2	450mm	To remove lid and access internals
3	150mm	To allow for tube and cables entry (side dependent)
4	10mm	If no access required (side dependent)
-	< 3000mm	Recommended length of cable runs

Table 13: Space requirements

3.4 Hydraulic Requirements



Sunamp Ltd. Heat Batteries are NOT suitable for tank-fed hot water systems.

- All connection tube work inside the Heat Battery casing must be **Ø 22mm copper tube**. This to allow the earth connection between the case, inlet, and outlet tube fittings.
- Ensure that the unit is **electrically isolated** from mains and that the controller lid is closed whilst performing any hydraulic pipework. This is to avoid water or particles coming into contact with the PCB and other electrical components.
- DO NOT fit Isolation valves between the expansion vessel and the Heat Battery.
- The tube grommets used for inlet and outlet into the Heat Battery must be cut to allow the passage of the copper tubes by safely using an appropriate cutting tool.
- Although Ø22mm copper or equivalent plastic tube work should suffice in most installations:
 - Plastic tube work must not be used inside the heat battery and no plastic tube connections must be made to the heat battery inlet or outlet ports.
 - It is recommended that sizing of the tube work should consider mains water supply pressure, the design flow rates, size of the Heat Battery and pressure loss.



- As a mandatory requirement it is necessary to install an energy supply cut off valve or equivalent (i.e. 2-way port valve or 3-way port valve) on the Heat Pump Flow circuit.
- When connecting to a heat pump, a bypass valve should be fitted between the heat pump outlet flow and return, prior to any energy supply cut off valves or equivalents.
- Ensure that the Heat Pump indoor unit is installed in close proximity to the Heat Battery. The signal cable length provided should not be exceeded.

3.5 Temperature and Insulation Requirements



Applying excessive heat to the system tubes will cause damage to the Heat Battery and its internal components.

- Heat Batteries use the Plentigrade® P58 Phase-Change Material (PCM), which has a **phase transition temperature of 58°C**.
- All connected tubes should be insulated for **at least 1m** from their connection points with the Heat Battery.
- The flow temperature of the Heat Pump must not exceed 80°C.

3.6 Electrical and Wiring Requirements

All range models within this manual are fitted with an internal controller situated at the top of the Heat Battery. Two wiring options are available:

1. **Thermino hp-SG option 1:** Samsung Low Temperature Heat Pump (Fig. 12.1 & 12.2)
2. **Thermino hp-DN option 2:** Daikin Low Temperature Heat Pump (Fig 13.1 & 13.2)

Regardless of the option chosen, the Heat Battery is charged by the Heat Pump from bottom to top (C to B) and discharges hot water draw-off from top to bottom (A to D). When operating in a backup mode the heating element charges the Heat Battery from bottom to top.

3.6.1 General



External wiring to the Heat Batteries must be in accordance with current IET (BS.7671) Wiring Regulations and any other applicable local regulations. **Local Means for disconnection must be incorporated in the fixed wiring in accordance with the wiring rules.**



Note: The lid cover of the controller can be removed by using a flat head screwdriver.

- The Heat Batteries must be earthed correctly.
- The point of connection to the mains should be readily accessible and adjacent to the Heat Battery installation.
- The product must have its own **dedicated 16A MCB protected** supply.
- Connection must allow isolation of the electrical supply, such as a double pole switch having a 3mm (1/8") contact separation in both poles. The means of isolation must be accessible to the end user after installation.
- All models are designed with an integrated electric heater. Install in accordance with the instructions provided (3.7 & 3.8).
- All models are fitted with only one 2.8kW heating element at ~230V AC and therefore recharging times increase with size of the Heat Battery when using the heating backup mode.
- The mains power cable to the Sunamp Controller should be a minimum of 2.5mm², 3 core H05 VV-F sheathed cable, to BS 6500. This cable must be prepared according to Figure 10 (below), where the Green/Yellow (Protective Earth) wire is 15 mm longer than the Brown (Live) and Blue (Neutral) wires.

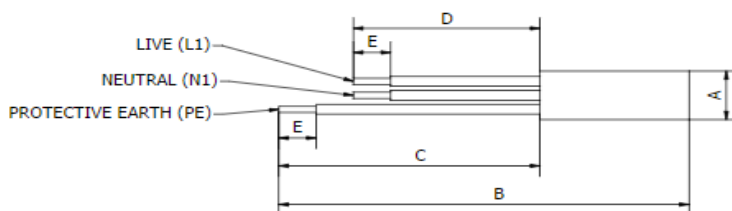

Figure 10: Wire length preparation diagram

Item	Description
L1	Live
N1	Neutral
PE	Protective Earth



A	Ø10.5mm MAX
B	< 3000mm from Heat Battery to fixed disconnection
C	75mm
D	60mm
E	8mm

Table 14: Wire lengths

3.6.2 Controller Wiring Diagram

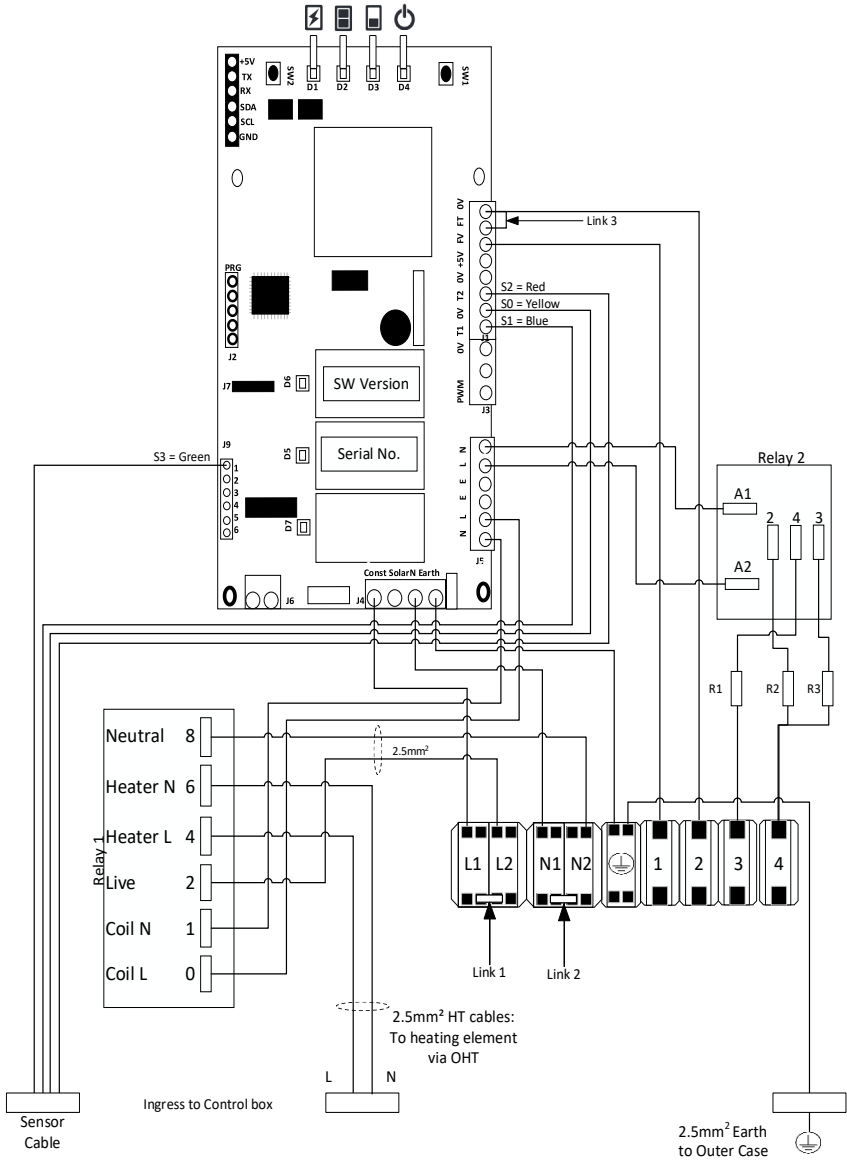

Figure 11: Internal controller wiring diagram (wire sizes=0.75mm², unless stated otherwise)

3.7 Wiring Option 1 – Thermino hp-SG Low Temperature Heat Pump



Important: Please follow (Table 15.1) for information regarding the Links.

Link specification	Removed or Fixed
Link 1	Fixed (Factory setting)
Link 2	Fixed (Factory setting)

Table 15.1: Wiring Option 1 - Link 1 & 2 settings



Link 3 will be provided fixed within the product; this can be removed to meet the functionality required in (Table 15.2). Please isolate the electrical power to the unit if the Link requires removal.

Link specification	Removed or Fixed	Functionality
Link 3	Fixed (Factory setting)	Back-up timer function enabled (heat battery will charge electrically after a 45 minute delay timer has run out and heat demand is still present)
	Removed	Removes delay timer function, internal element operation is now only controlled by the heat pump controller

Table 15.2: Wiring Option 1 - Link 3 setting

- Link 1 & Link 2 are NOT to be removed, as this will lead to malfunction of the Heat Battery.
- Run and connect 3 Core mains power supply cable (16A minimum, minimum 2.5mm² CSA) from the double-pole isolating switch to the Heat Battery controller (Figures 12.1 and 12.2).
- Wire the cable via the appliance case grommets and into the control box housing (Figures 8, 12.1 and 12.2).
- Prepare the wire according to (Figure 10) and wire the mains power cable in the following terminals (Figure 12.2):
 - **Brown (Live):** Terminal L1 (Live)
 - **Blue (Neutral):** Terminal N1 (Neutral)



- **Green/Yellow (Earth):** Terminal PE (Protective Earth)

3.7.1 **Booster signal wiring**

Wire the 2 core PVC insulated cable provided (C2295) from the Samsung "MIM-E03AN" Booster heater terminal connectors "L" & "N" (please refer to Heat Pump manual), run the wire into the relay box (C2291) provided into "TRIGGER INPUT AC" terminals (please refer to relay box instruction sheet). Then wire another 2 core PVC insulated cable provided (C2295) from the relay box terminals "NO1" & "C1" to the Heat Battery, into the control box housing through the opening available. Secure the cables in Terminal T1 & T2 independently (Figure 12.2). Please note that the polarity of the wires is not important in this wiring setup. Please ensure to use the provided relay backbox (C2292) & 2 x Cable grommets (C2296) when running the wires into the relay box.



Note: Engaging this booster signal on the heat pump controller will put the Heat Battery into electric charging mode. This can lead to increased electricity consumption, resulting in higher energy costs. This should be explained to the end user.

3.7.2 **Heat Pump Control Signal**

- Using the Samsung Tank sensor part supplied "CNS042" with the heat pump, remove the sensor end, by cutting off the copper cylinder and strip the wire as required. Add the connector end into the Samsung "MIM-E03AN" (please refer to Heat Pump manual), then run the wire into the Heat Battery via the Heat Battery case cabling grommets and then into the control box housing through the hole available. Secure the cables in Terminals T3 & T4 independently (Figure 12.2).

3.7.3 Controller Wiring Schematic and Diagram

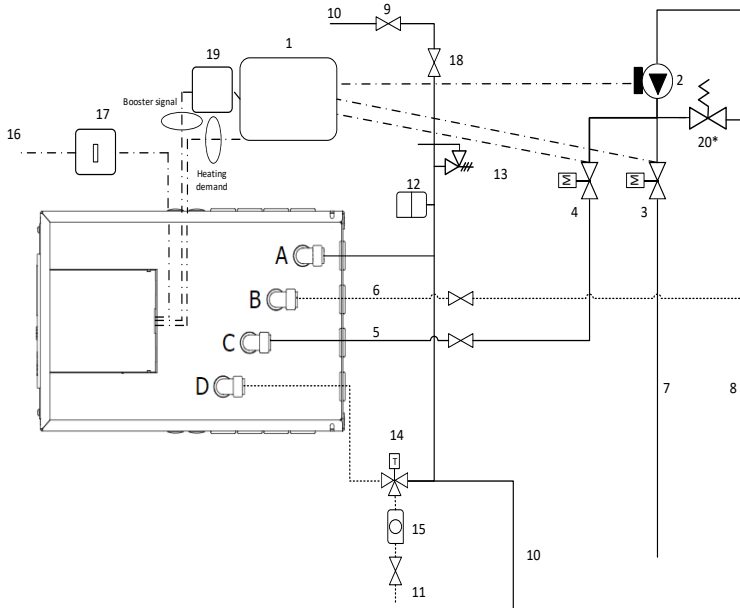

Figure 12.1: Example Wiring Option 1 Schematic (see Figure 3 for piping and electrical options available)

Item	Description	Item	Description	Item	Description
1	Samsung "MIM-E03AN" Heat Pump Controller	8	Central Heating Return	15	Hot Water flow regulator
2	Circulation pump (*1)	9	Check Valve	16	230VAC 16A power supply
3	Central heating Zone Valve	10	Mains Cold Water Supply	17	Double-pole isolating switch (min. 16A)
4	Heat Battery Charging Zone Valve	11	Hot water supply to dwelling	18	Cold Water Mains Pressure regulator
5	Flow from Heat Pump	12	Expansion Vessel	19	Relay Box

6	Return to Heat Pump	13	Mains Expansion Relief Valve (max. of 10 bar)	20	Auto-bypass valve (*2)
7	Central Heating Flow	14	Hot Water Tempering Valve		

Notes:-

*1 The circulation pump may be located in the Heat Pump enclosure and is controlled by the heat pump controller, please check Heat Pump manual.

*2 Auto-bypass valve should only be fitted to allow for minimum flow in defrost mode if flow rates and heat battery pressure drops exceed the pressure limitations of the heat pump circulation pump.

Table 15.3: Explanation of components

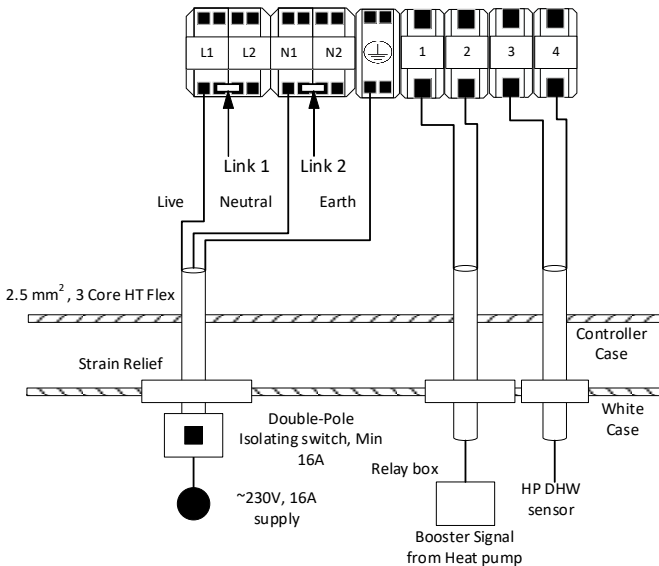

Figure 12.2: Wiring Option 1 diagram – Thermino hp-SG Low Temperature Heat Pump

3.8 Wiring Option 2 – Thermino hp-DN Low Temperature Heat Pump



Important: Please follow (Table 16.1) for information regarding the Links.

Link specification	Removed or Fixed
Link 1	Fixed (Factory setting)
Link 2	Fixed (Factory setting)

Table 16.1: Wiring option 2 – Link settings



Link 3 will be provided fixed within the product; this can be removed to meet the functionality required in (Table 16.2). Please isolate the electrical power to the unit if the Link requires removal.

Link specification	Removed or Fixed	Functionality
Link 3	Fixed (Factory setting)	Back-up timer function enabled (heat battery will charge electrically after a 45 minute delay timer has run out and heat demand is still present)
	Removed	Removes delay timer function, internal element operation is now only controlled by the heat pump controller

Table 16.2: Wiring Option 1 – Link 3 setting

- Link 1 & Link 2 are not to be removed, as this will lead to malfunction of the Heat Battery.
- Run and connect 3 Core mains power supply cable (16A minimum, minimum 2.5mm² CSA) from the Double-pole isolating switch to the Heat Battery controller (Figures 13.1 and 13.2).
- Wire the cable via the appliance case cabling grommets and then into the control box housing through the hole available (Figures 8, 13.1 and 13.2).
- Prepare if necessary, the mains power cable and wire in the following terminals (Figure 10):
 - **Brown (Live):** Terminal L1 (Live)
 - **Blue (Neutral):** Terminal N1 (Neutral)



- **Green/Yellow (Earth):** Terminal PE (Protective Earth)

3.8.1 **Booster signal wiring**

- Using the cable assembly provided (C2293), plug the connector end in the Daikin Indoor unit “EHBH04/8D6V” controller PCB plug terminal X13A (please refer to Heat pump manual). Then run the cable out of the Daikin indoor unit and into the relay box (C2291) provided into “TRIGGER INPUT AC” terminals (please refer to relay box instruction sheet). Then wire the 2 core PVC insulated cable provided (C2295) from the relay box terminals “NO1” & “C1” to the Heat Battery, into the control box housing through the hole available. Secure the cables in Terminal T1 & T2 independently (Figure 13.2). Please note that the polarity of the wires is not important in this wiring setup. Please ensure to use the provided relay backbox (C2292) & 2 x Cable grommets (C2296) when running the wires into the relay box.



- **Note:** Engaging this booster signal on the heat pump controller will put the Heat Battery into electric charging mode. This can lead to increased electricity consumption, resulting in higher energy costs. This should be explained to the end user.

3.8.2 **Heat Pump sensor cable wiring**

Using the cable assembly provided (C2294), place the connector end in the Daikin indoor unit controller “EHBH04/8D6V” PCB connector “X9A” (please refer to Heat Pump manual) , then run the wire into the Heat Battery via the Heat Battery case cabling grommets and then into the control box housing through the hole available. Secure the cables in Terminals T3 & T4 independently (Figure 13.2).

3.8.3 **Wiring of Daikin Hydromodule**



Jumper Terminal 10 to 11a on terminal bed X2M, using a 0.75mm² wire.

3.8.4 Controller Wiring Schematic and Diagram

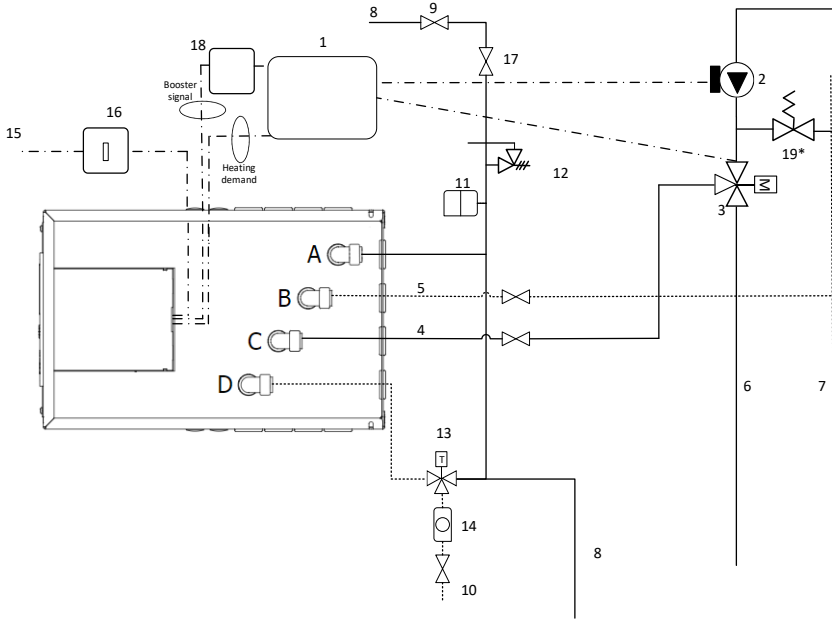

Figure 13.1: Example Wiring Option 2 Schematic (see Figure 3 for piping and electrical options available)

Item	Description	Item	Description	Item	Description
1	Daikin Indoor Unit "EHBH04/8D6V" Heat Pump Controller	8	Mains Cold Water Supply	13	Hot Water Tempering Valve
2	Circulation pump (*1)	9	Check Valve	15	230VAC 16 A power supply
3	Motorised Three port Valve	10	Hot water supply to dwelling	16	Double-pole isolating switch (min. 16A)
4	Flow from Heat Pump	11	Expansion Vessel	17	Cold Water Mains Pressure regulator

5	Return to Heat Pump	12	Mains Expansion Relief Valve (max. of 10 bar)	18	Relay box
6	Central Heating Flow	13	Hot Water Tempering Valve	19	Auto-bypass valve (*2)
7	Central Heating Return	14	Hot Water flow regulator		

Notes:-

*1 The circulation pump may be located in the Heat Pump enclosure and is controlled by the heat pump controller, please check Heat Pump manual.

*2 Auto-bypass valve should only be fitted to allow for minimum flow in defrost mode if flow rates and heat battery pressure drops exceed the pressure limitations of the heat pump circulation pump.

Table 16.3: Explanation of components

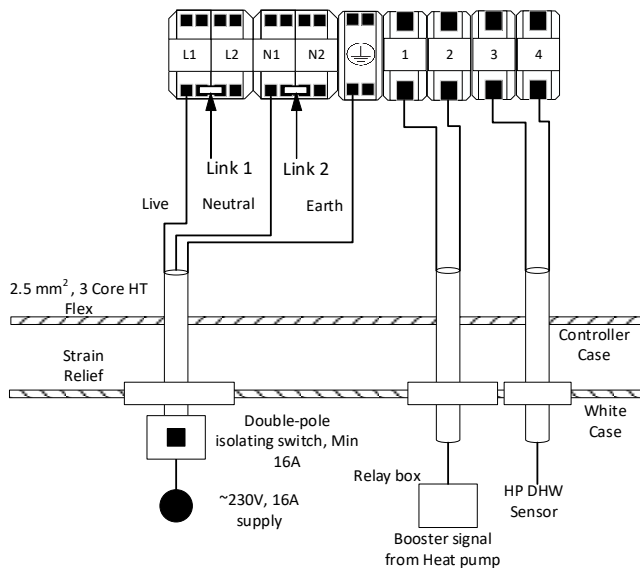

Figure 13.2: Wiring Option 2 - *Thermino hp-DN Low Temperature Heat Pump*

4 Commissioning



Before commissioning the product, first ensure that you have properly reviewed the previous sections, particularly in regard to Heat Battery specifications as well as location, electrical supply and water supply requirements.



The Heat Battery and its associated pipework **MUST** be filled and fully vented before the Heat Battery power supply is switched ON.

4.1 Preparation

- Ensure all packaging material has been removed.
- Ensure all components are clean and undamaged.

4.2 Process

1. Ensure that the temperature sensor of the Heat Battery is fully inserted into its pocket. The white marker should be sitting on top of the blue cable gland.
2. Turn on the water supply and ensure that there are no leaks.
3. Fully open any hot water taps in the dwelling and allow to run for a **minimum time of 2 minutes**. This is for any air to leave the system. This may vary depending on Sunamp Ltd. Heat Battery model size.

Note: For larger models such as the Thermino 210 hp(-DN&-SG) , the **minimum time is increased to 4 minutes**.

4. Switch ON the power supply to the Heat Battery, via the Double-pole isolating switch, min 16A.
5. Switch ON the power supply to the Heat Pump, via its dedicated isolator.
6. Ensure that the correct settings are made on the Samsung (Table 17; Section 4.3.1) or Daikin (Table 18; Section 4.3.2) Heat pump controller. (NOTE: At this stage the Heat Pump controller should show the tank temperature to be ~40°C, this will change to 70°C when the battery is fully charged. No intermediate temperatures are displayed.)



7. Test the booster function by manually overriding the booster section on the heat pump controller, after enabling this. Please reset the boost function to the relevant setting displayed in Section 4.3 if required.
8. Continue to run the tap for a further **2 minutes**, then close.
9. Check the front of the Heat Battery to ensure that the “power” and “heater” LED’s are lit (see Table 19).
10. Allow the Heat Battery to charge for approximately **30 minutes** with the hot water tap closed.
11. After 30 minutes open the hot water tap and check for hot water.
12. Adjust the Hot Water Tempering Valve, so that the output temperature is **45°C to 55°C, depending on installation requirements**.
13. Check hot water temperature at all hot water outlets in the dwelling with the customer and advise on temperature settings.
14. Ensure that the Heat Battery charges to half charge and that the power light is not rapidly flashing (which may otherwise indicate an error, see table 20, section 5).
15. Leave all product information and literature with the customer / end user.



Fill in and return the Sunamp Ltd. commissioning certificate, provided with the product. **These documents MUST be compiled and returned to Sunamp after installation.**

4.3 Heat pump settings

Please ensure that the heat pump’s settings are set to the following for the Daikin and Samsung Low Temperature Heat Pumps. Please refer to the relevant heat pump manufacturer manual to apply the settings in the sections below (Table 17 & 18).

4.3.1 Samsung setup

To set up the Samsung Heat Pump please go to the **Field Setting Values (FSV) page** on the wired remote controller.

Setting	Set to	FSV #
DHW tank temp	65 °C	1051
Heat pump max temp	55°C	3021

Max. DHW operation time	95 minutes	3025
Legionella cycling	0 (Off)	3041
dT(Flow/Return)	~7°C	

Table 17: Samsung Heat Pump settings

In the **user-accessible menu**, the DHW tank temperature set point should be set to 65°C.

4.3.2 Daikin Setup

To set up the Daikin Heat Pump please go to the **Main menu** on the Hydromodule controller

Setting	Set to
Tank mode	On
Domestic Hot Water	EKHWS/E Tank with booster heater installed at the side of the tank.
Emergency	Auto SH reduced/ DHW off
Setpoint mode	Fixed
Heat up mode	Schedule Plus Reheat (define this with end user, it is important to allocate a daily time window of 2 hours minimum if using schedule only)
Comfort setpoint	69°C
Reheat setpoint	45°C
DHW Hysteresis	8
Disinfection	Disabled
Target dT(Flow/Return)	~7°C
DHW Maximum set-point [6-0E]¹	70°C
¹ This setting can be found in the Hydromodule Field Settings Menu.	

Table 18: Daikin Heat Pump settings

5 Operation



Always read the safety instructions in Section 1 of the manual before operating the **Thermino hp(-DN & -SG)** Heat Batteries.

5.1 Switch On/Off

Power is supplied to the Heat Battery via the Double-pole isolating switch, Min 16A. The Heat Battery will remain in operation whilst it is connected to the mains. The Heat Battery will switch off if you disconnect it from the mains.

5.2 LED Indicators and Status

LED Indicators are available to observe the status of the **Thermino hp(-DN & -SG)** Heat Battery installed.





	Status	Meaning
	OFF	Power OFF
	ON	Power ON
	Rapidly Flashing	Temperature Sensor Fault (see Table 20)
	Pulsing	Heat Battery charging from 0 - 50%
	ON	Heat Battery charge level >50%
	Off	Heat Battery charge level 0 - 50%
	Pulsing	Heat Battery charging from 50 - 100%
	Solid	Heat Battery charge level 100%
	Off	Heating element INACTIVE
	Solid	Heating element ACTIVE

Table 19: LED indicators



5.3 Troubleshooting

5.3.1 During Installation

Fault	Possible Cause(s)	Possible Solution
The appliance does not deliver hot water after installation	Fault with Low Temperature Heat Pump	Any Faults on the Low Temperature Heat Pump are displayed on its controller, please refer to the Heat pump manual.
	No Temperature showing for DHW on Heat Pump controller.	Check wiring between HP DHW sensor terminals and Heat Battery controller T3 & T4 (Figures 12.2 & 13.2)
	Appliance not powered or not powered correctly	Check wiring and power supply and rectify where necessary.
	Non-self-resetting thermal cut-out has tripped	Make sure the appliance is full of water and purge if necessary: <ol style="list-style-type: none">1. Disconnect the power supply2. Open the electrical cover at the base of the unit.3. Reset the non-self-resetting thermal cut-out.4. Check if the temperature sensor is fully inserted in the Heat Battery (section 4.2, 1)5. Reassemble the unit, and6. Reconnect the supply. If the problem persists, please contact Sunamp Ltd.
LED D4 (power symbol) is rapidly flashing	Temperature sensor string is faulty	Check that the sensor cable is properly connected to the PCB and that the connector block is properly pushed in. If the problem persists, please contact Sunamp Ltd.
The flowrate from the	Air might still be trapped in the system	Check that the mains supply valve is fully opened.

appliance is lower than expected		Make sure the appliance is fully de-aired and purge if necessary.
	Incoming water pressure is too low	Measure the incoming pressure from the mains supply and contact Sunamp Ltd.

Table 20: Installation Troubleshooting

5.3.2 After Installation or During Use



Warning: This product does not contain any user-serviceable or user-settable components. All fault-finding and fault-remediation works therefore need to be carried out by a competent person

Fault	Possible Cause(s)	Possible Solution
No hot water	Fault with Low Temperature Heat Pump	Any Faults on the Low Temperature Heat Pump are displayed on its controller, please refer to the Heat pump manual.
	Power supply has been temporarily or permanently disconnected.	Check power supply. If power supply ON call your installer.
	The off-peak switch is not on (if fitted)	If the power supply is OFF, switch on and wait for hot water. If the power supply fails again call installer.
Water leak	Various	Isolate the water and electricity supply to the unit and contact your installer.

Table 21: Post-installation troubleshooting

6 Maintenance



Where undertaking maintenance, repairs, or removals and where necessary, ensure that the system is first disconnected from the electrical and/or water supply.

- The product does NOT require any regular maintenance.
- In areas, where the mains water hardness can exceed 150 ppm Total Hardness and a scale-reducing device has been fitted, the service and maintenance requirements of this device (especially re-fill requirements) need to be adhered to.
- The air pressure in the expansion vessel should be checked every 2-3 years and topped up if necessary.
- If the supply cord is damaged, it must be replaced by the manufacturer, its service agent or similarly qualified persons in order to avoid a hazard, please refer to the Electrical wiring sections (3.6 - 3.8).

6.1 Removal of Lids



Warning: Disconnect power mains before accessing (live components on PCB). Strictly no live parts.

- The lid of the Sunamp Ltd. Heat Battery is fixed to the outer case using **2 x M5 Button Head cap screws**. These can be undone by using a **3mm hexagonal Allen key** (Figure 7).
- The terminal cover plate can be removed by unscrewing the **2 x M5 Button Head cap screws**. These can be undone by using a **3mm hexagonal Allen key**.
- The lid of the controller cover is a snap fit lid to be pried off with a flat head screwdriver to be removed.

6.2 Cleaning

- The product does not require any regular cleaning.
- Should the product exterior have become dirty it can be wiped down with a damp cloth and a mild detergent (such as soap) after having been isolated from the electricity supply. Let the appliance dry before reconnecting the electricity supply.

6.3 Warranty



Information regarding product warranty can be found on the Sunamp Ltd website: www.sunamp.com/warranty.

7 Recycling and Disposal



This symbol on the product and accompanying documents means the product should not be mixed with general household waste at the end of its life.

For proper treatment, recovery and recycling, please take this product to designated collection points where it will be accepted free of charge at the end of its life.

Disposing of this product correctly will help save valuable resources and prevent any potential negative effects on human health and the environment, which could otherwise arise from inappropriate waste handling.

Please contact your local authority for further details of your nearest designated collection point. Penalties may be applicable for incorrect disposal of this waste, in accordance with your national legislation.

Manual Part Number: D0056

Version Number: 1

Publication Date: 15/12/2021

Sunamp Ltd.
1 Satellite Park
Macmerry
East Lothian
Scotland, EH33 1RY
General Enquiries +44 (0)1875 610001
info@sunamp.com
www.sunamp.com

