

# Schematic Book

## Sunamp Thermino xPlus

for Samsung Heat Pump



**SAMSUNG**



**MIDSUMMER**

Delivering tomorrow's energy



# Mechanical Schematic

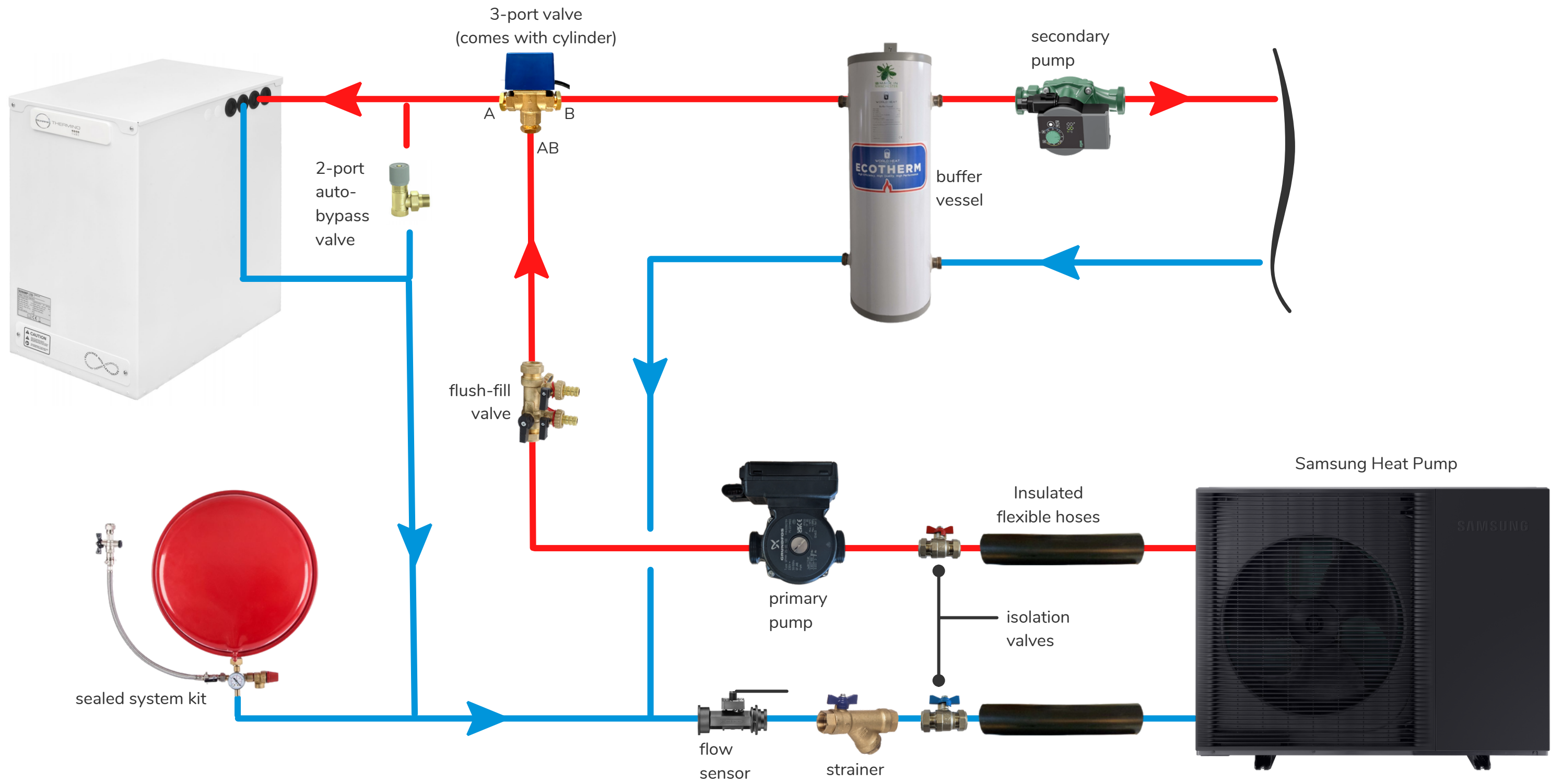

# xPlus Pipework Connections

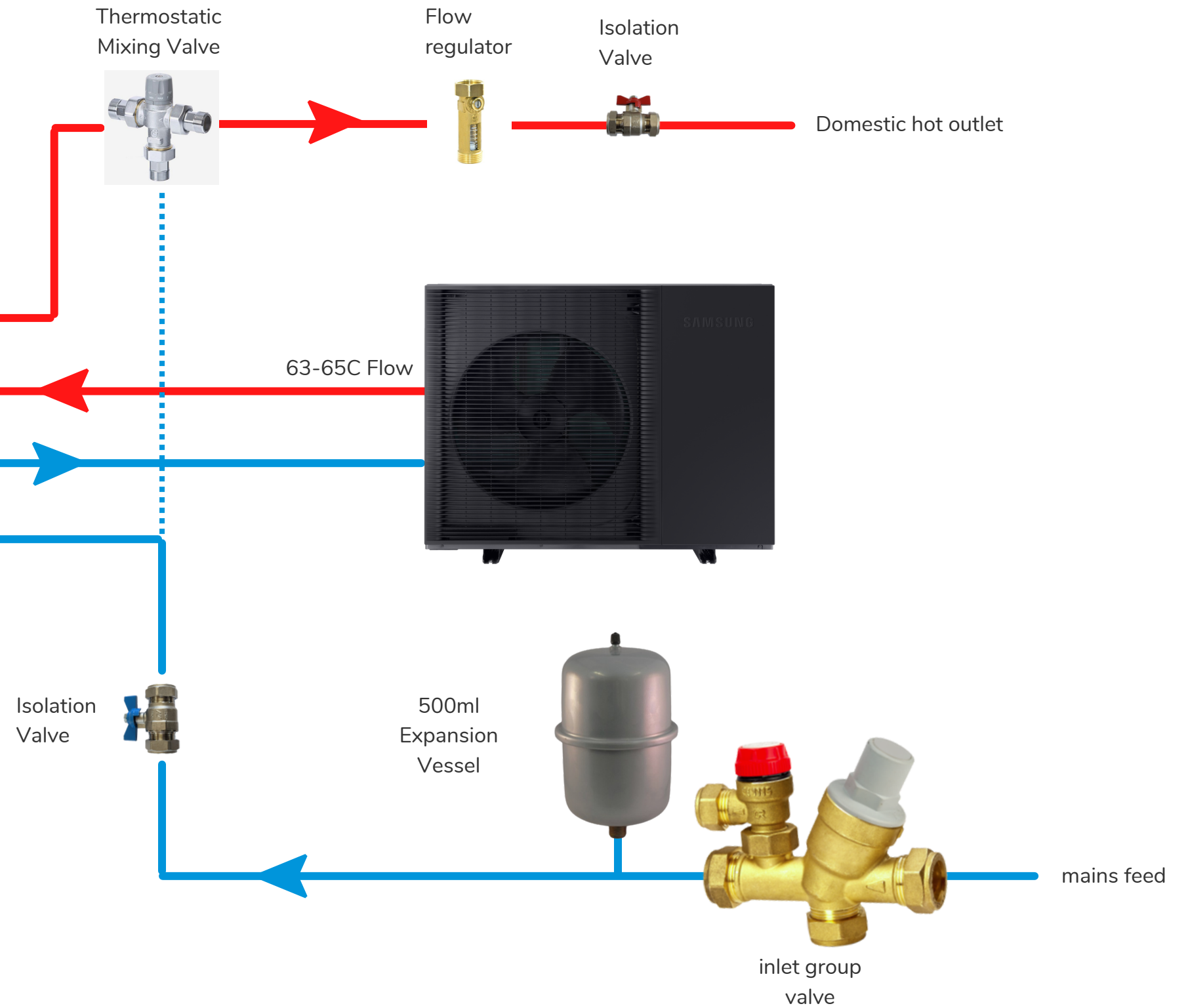
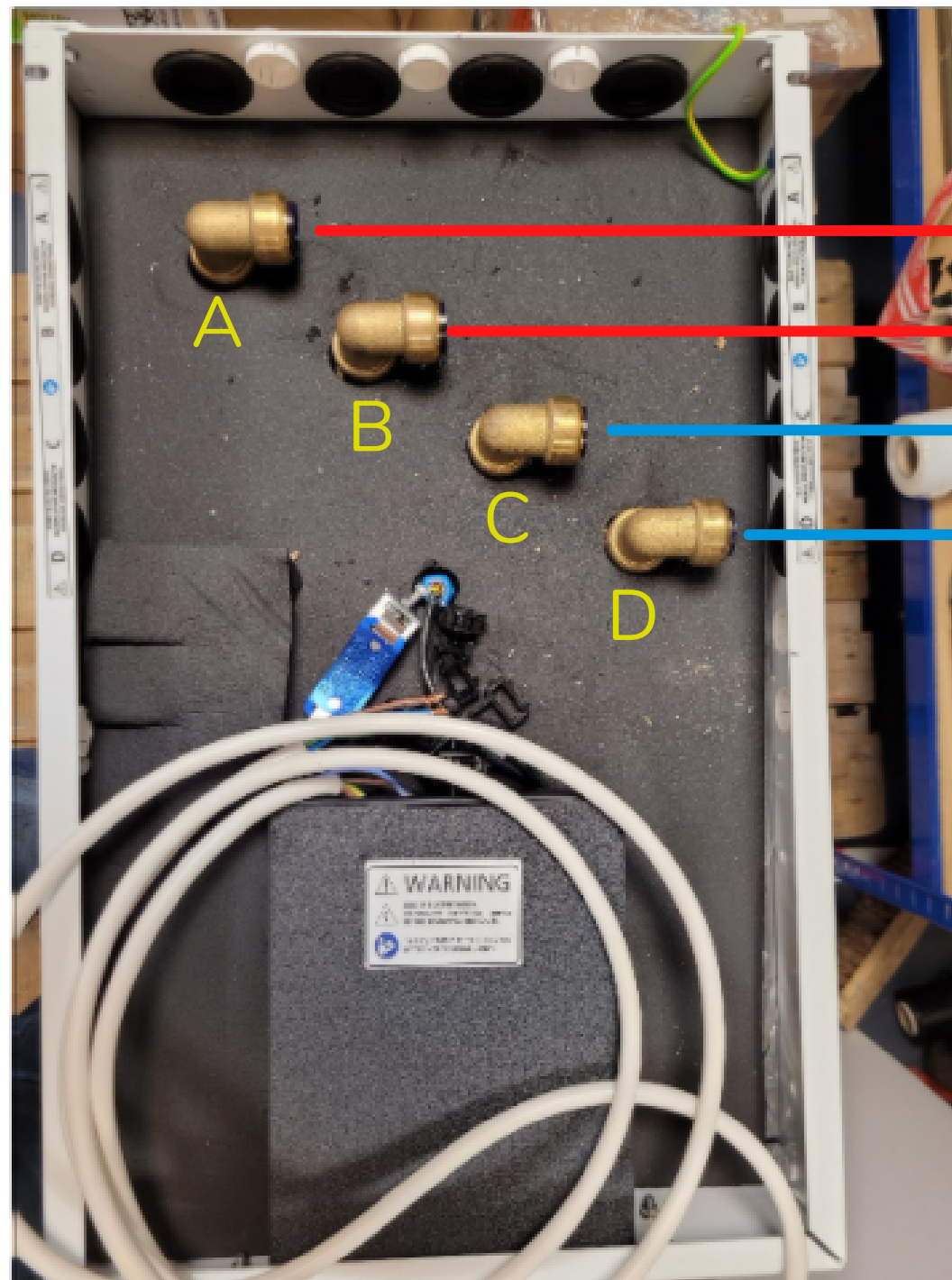

# Main Power Diagram



Breaker for heat pump:  
5kW - 16A  
8kW - 25A  
12kW - 32A  
16kW - 32A



Local 3-pole isolator:  
5kW - 25A (min)  
8kW - 25A (min)  
12kW - 32A (min)  
16kW - 32A (min)



Breaker for control board:  
16A

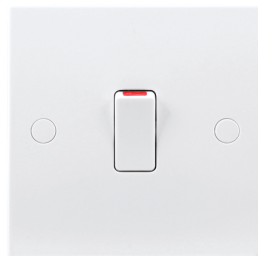

Local 20A double-pole switch



Breaker for Thermino:  
16A



Local 20A double-pole switch



# Wiring Diagram

**SAMSUNG**

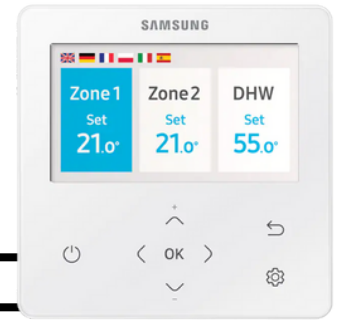
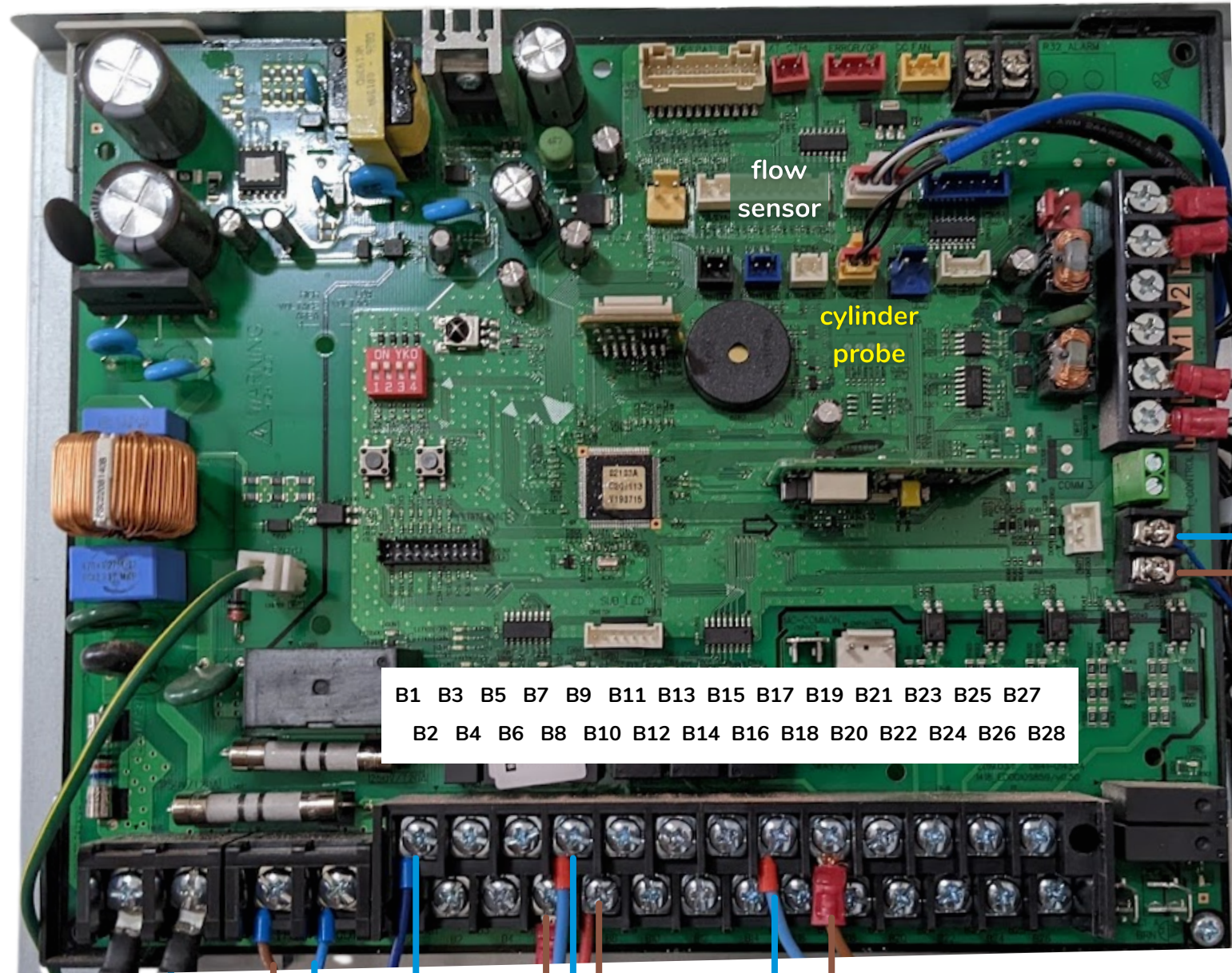

LCD stat  
F3, F4



heat pump  
F1, F2

These cables need to be screened.  
e.g. 1mm<sup>2</sup> CY cable



incoming power A1, A2



Sunamp  
immersion  
heater relay  
A3, A4

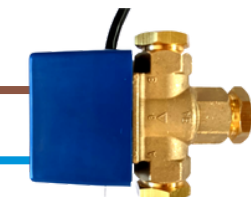

3-port valve  
B15, B17



secondary  
pump  
B7, B8



primary  
pump speed control  
top, bottom

primary  
pump power  
B1, B6

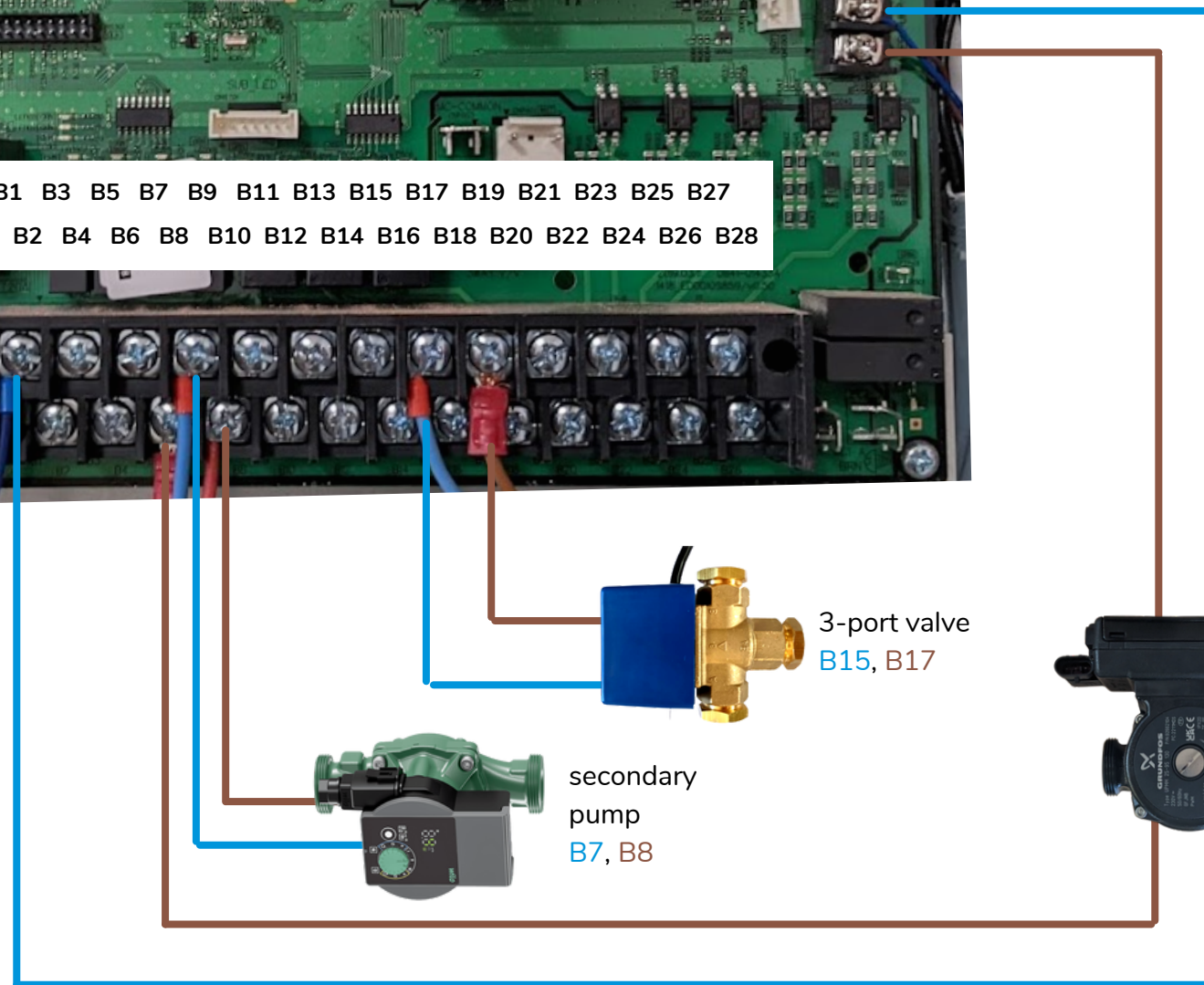

# xPlus Controls Wiring - No PV

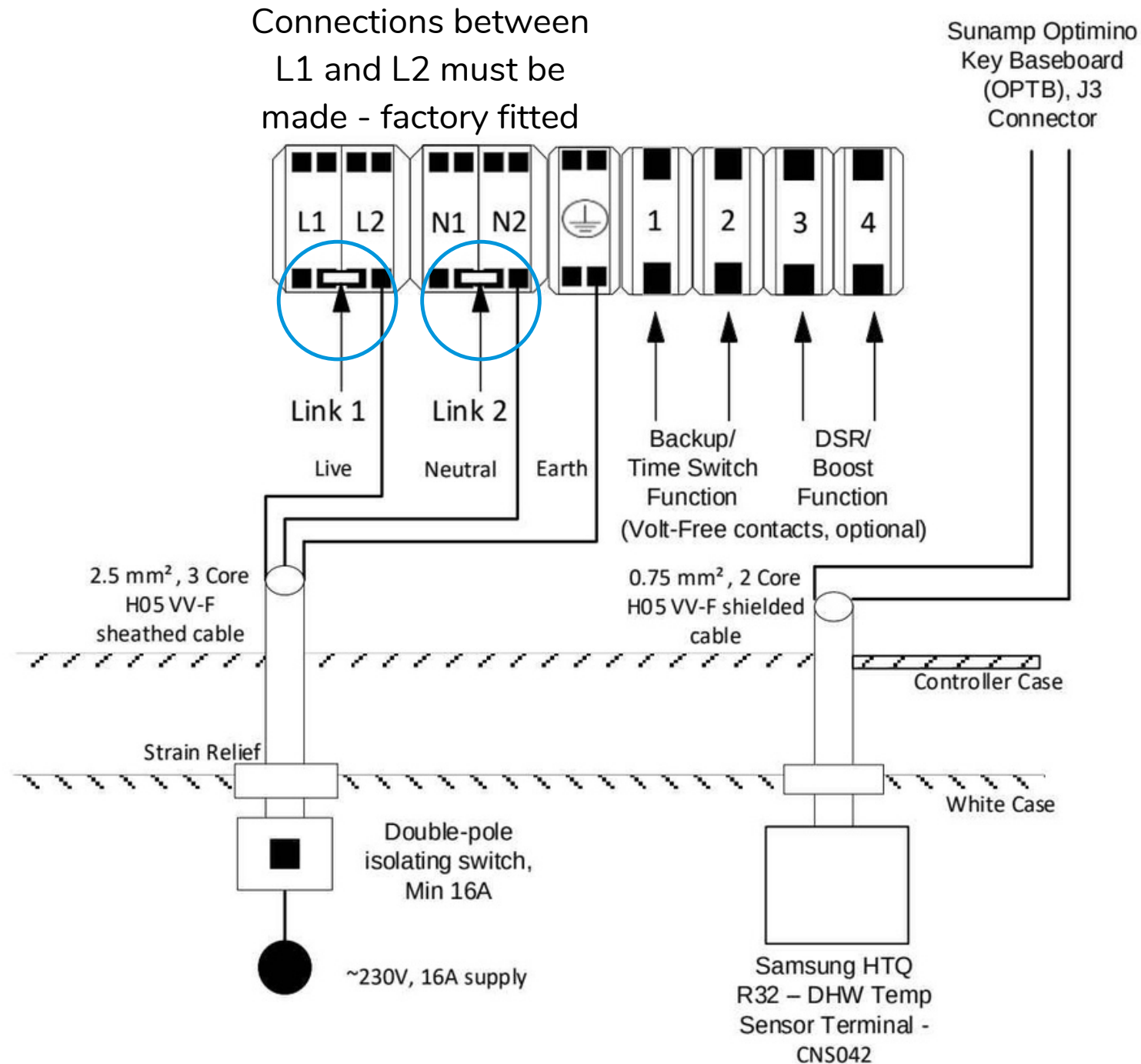

## WARNING

If using a Samsung Gen 6 ASHP then you must make a connection between terminals FT and 0V on the main board using 0.75mm wire.

# xPlus Controls Wiring - With PV



Connections between L1 and L2 must be **REMOVED**

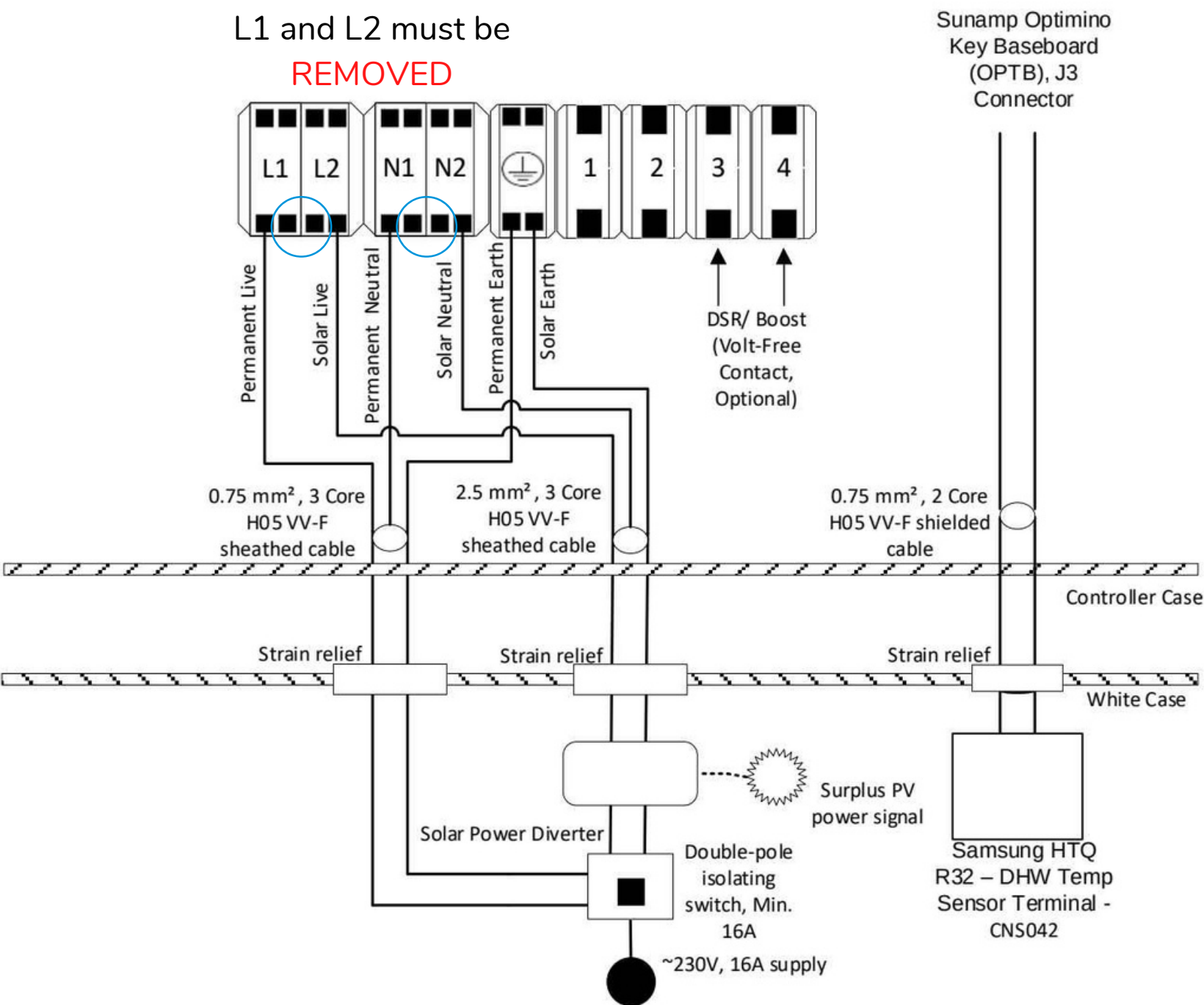

## WARNING

If using a Samsung Gen 6 ASHP then you must make a connection between terminals FT and 0V on the main board using 0.75mm wire.

## Accessing service mode

To get into service mode for testing and setting up the heat pump you need to press and hold **up and down** for 5 seconds. The controller will then ask you to enter the PIN which is **0202**

## Check the flow-rate

Enter Service Mode, go to **Indoor Zone Option** then **Indoor Zone Status Information** and it will show a value for **flow sensor** in litres per minute.

SAMSUNG



## Samsung Thermostat

The heat pump control is a bit more clever when you use the Samsung controller as the thermostat. This is the ideal option if you can find a route for the cable to a sensible thermostat location.

To use the Samsung LCD controller as the thermostat enter service mode and go to:

### Indoor Zone Option

and set

### Standard Temperature to Indoor

Now the controller is set up to act as the thermostat with the temperature setting via the Samsung LCD.

## External Thermostat

If you need to use an external, 3rd party thermostat with a Samsung heat pump this needs to be wired up as shown below. Permanent live is **B20**, switched live is **B22**.



Then set the heat pump to use it as the signal to heat or not by setting **FSV 2091** - External Thermostat Application #1 (Floor) to **Use(Signal ON/OFF) or WL Interlink OFF(Water Pump3)**.

## Heating - Weather Compensation

Samsung's name for weather compensation is "water law". You need to set up the water law before the heat pump will perform weather compensation properly. On a Samsung you set a warm weather point and a cold weather point and then the unit interpolates between them to provide the flow temperature asked for.

To do this you need to enter service mode, "Field Setting Value" and input the settings.

### 20\*\* Water Law

#### 201\* Outdoor Temp. for Water Law (Heat)

Low = 20°C

High = -3°C

#### 202\* Water Out Temp. for WL1 Heat (WL1-Floor)

Low target value

25°C

High target value

50°C

Note: the two numbers inside the green boxes are the design condition, in this case shown as flow temp of 50°C at air temp of -3°C.

## Hot water settings (FSV)

**3011** - Domestic Hot Water Tank - **Use(Hysteresis Thermo ON/OFF state)**

**3025** - Max DHW Operation Time - you want to give your heat pump a decent chance of heating the water up in one go here, but not let the house get cold while you do it. If it's a well insulated house you can set this time fairly long, if it's a poorly insulated house you can set it shorter. **90 minutes** is a reasonable starting point for most cases.

**3032** - Delay time - This is how long the heat pump tries to do the hot water using the heat pump before it kicks in the immersion heater to help. You don't really want this to happen often so set this to **60 minutes**.

**3041** - No need for a disinfection/legionella cycle with a Sunamp Thermino. Setting should be **Not use**.

