

We support PV systems

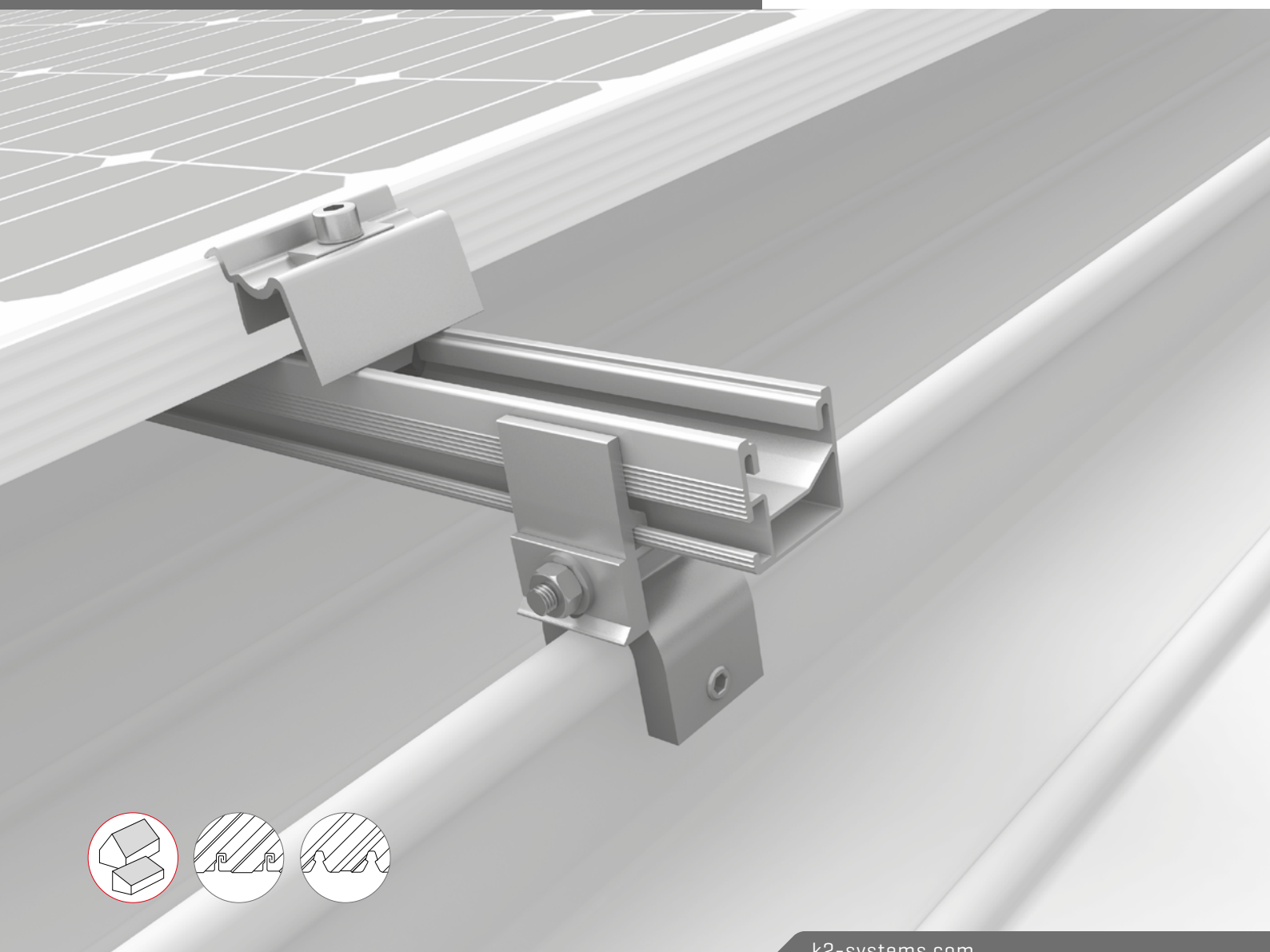

Standing seam clamps and clamps for metal roof systems with SolidRail or SingleRail

ASSEMBLY INSTRUCTIONS



Content

/ Tools overview	3
/ General safety information	4
/ The following generally applies:	5
· Planning with K2 Base	5
· Requirements for the roof	5
· Static requirements	5
· Important assembly information	5
/ Components	6
/ Available standing seam clamps and rail connection	8
· Compatible with SingleRail	8
· Compatible with SolidRail	9
/ Assembly	12
· Basic assembly	12
· Portrait: 1 rail position	14
· Landscape: 2 rail positions, clamping of long module edge	15
· Landscape: 1 rail position, clamping of short module edge	16
· Thermal separations	17
/ Notes	18

Quality tested – several certifications

K2 Systems stands for secure connections, highest quality and precision. Our customers and business partners have known that for a long time. Independent institutes have tested, confirmed and certified our capabilities and components.

Please find our quality and product certificates under:
www.k2-systems.com/en/technical-information

Tools overview

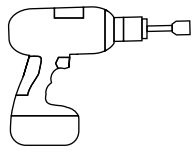

5 mm



6 mm



13 mm



15 mm



6 - 32 Nm
[4.5 - 22.2 lb-ft]



5 mm



6 mm



13 mm



15 mm

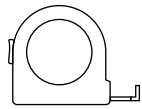

≥ 3.0 m



≥ 6.0 m

Digital Toolbox



Do you already know our digital services? Use our K2 DocuCheck App now and record the first important data directly at the customer or project site. Simply transfer the data to our online planning software K2 Base. Here you can plan your project easily, safely and quickly. You receive a detailed project report with assembly plan and static report. The K2+ interface enables seamless project data transfer to the planning tools of other manufacturers. With the K2 DocuApp, project documentation is done quickly and easily - without annoying paperwork.

Get started and register now:

app.k2-systems.com →

base.k2-systems.com →

docuapp.k2-systems.com →

General safety information

Please note that our general mounting instructions must be followed at all times and can be viewed online at www.k2-systems.com/en/technical-information

- The equipment may only be installed and operated by qualified and adequately trained installers.
- Prior to installation, ensure that the product complies with on-site static loading requirements. For roof-mounted systems, the roof load-bearing capacity must always be checked.
- National and local building regulations and environmental requirements must be adhered to.
- Compliance with health and safety regulations, accident prevention guidelines and applicable standards is required.
 - Protective equipment such as safety helmet, boots and gloves must be worn.
 - Roofing works must be in accordance with roofing regulations utilising fall protection safeguards when eaves height exceeds 3 m.
 - At least two people must be present for the duration of the installation work in order to provide rapid assistance in the event of an emergency.
- K2 mounting systems are continuously developed and improved and the installation process may thereby change at any time. Prior to installation consult our website at www.k2-systems.com/en/technical-information for up-to-date instructions. We can send you the latest version on request.
- The assembly instructions of the module manufacturer must be adhered to.
- Equipotential bonding/grounding/earthing between individual parts is to be performed according to country specific standards, as well as national laws and regulations.
- At least one copy of the assembly instructions should be available on site throughout the duration of the installation.
- Failure to adhere to our general safety and assembly instructions and not using all system components, K2 is not liable for any resulting defects or damages. We do not accept liability for any damage resulting in the use of competitor's parts. Warranty is excluded in such cases.
- German law shall apply excluding the UN Convention on CISG. Place of venue is Stuttgart. Our General Terms of Business apply.
- If all safety instructions are adhered to and the system is correctly installed, there is a product warranty entitlement of 12 years! We strongly recommend reviewing our terms of guarantee, which can be viewed at www.k2-systems.com/en/technical-information We will also send this information on request.
- Dismantling of the system is performed in reverse order to the assembly.
- K2 stainless steel components are available in different corrosion resistance classes. Each structure or component must be carefully checked for possible corrosion exposure.

The following generally applies:

The K2 standing seam system can be used routinely for most wind and snow loads. We recommend using our K2 Base measurement tool for calculating the effective span. Even if the system is capable of meeting higher demands through the integration of safety standards, please get in touch with your contact at K2 Systems if the specified values are exceeded.

Planning with K2 Base

We recommend our free online software K2 Base for the planning. In five steps, you can plan the right assembly system and get a construction recommendation, parts list and the structural analysis report. Simply register and start planning: base.k2-systems.com

Requirements for the roof

- Adequate roof cover holding force on the support structure or substructure.
- Roof incline: 5 - 75°

Static requirements

It is important to ensure that the roof cover and support structure can absorb the forces transmitted from the clamp to the seam.

Important assembly information

- The standing seam clamp may impede thermally induced changes in length under some circumstances. A distance of 17.5 cm between the standing seam clamp and the roof cover brackets (mounting bracket, clip, sliding cleat) must be taken into account to ensure the linear expansion of the roof cover.
- The installation company must initially check that the standing seam clamps are suitable for the intended purpose.
- If the roofing material is made of copper, standing seam clamps made of aluminium must only be used in combination with a stainless steel inlay in order to prevent electrochemical corrosion.
- Pre-position the standing seam clamps and slightly tighten the grub screw. Only tighten the standing seam clamps with the specified tightening torque after mounting the rails.
- For all clamp fixtures it is important to ensure that the first rail position is installed so that it runs transversely to the seam and, where applicable, with cross bracing.
- After a maximum of 6.6 m, the components must be thermally separated. For titanium zinc already after a maximum of 3.3 m!
- The general standards and regulations for lightning protection must be observed on site and, where appropriate, a specialist must be consulted in order to draw up a lightning protection concept (use a lightning protection clamp if necessary). Country-specific regulations must be observed.
- The tightening torque of all module clamps is 16 Nm.
- A minimum mounting distance of 50 mm from the end of the rail / rail joint to the module frame.
- Observe the manufacturer's specifications for the clamping range of the module clamps and for mounting the modules (see the manufacturer's module data sheet)
- The mounting components are not climbing aids!
- The system must be checked by a specialist company after exceptional events, such as storms, heavy rain, earthquakes etc. If deformed or loose components or other damage is determined when checking the system, these must be replaced with new components.

Components

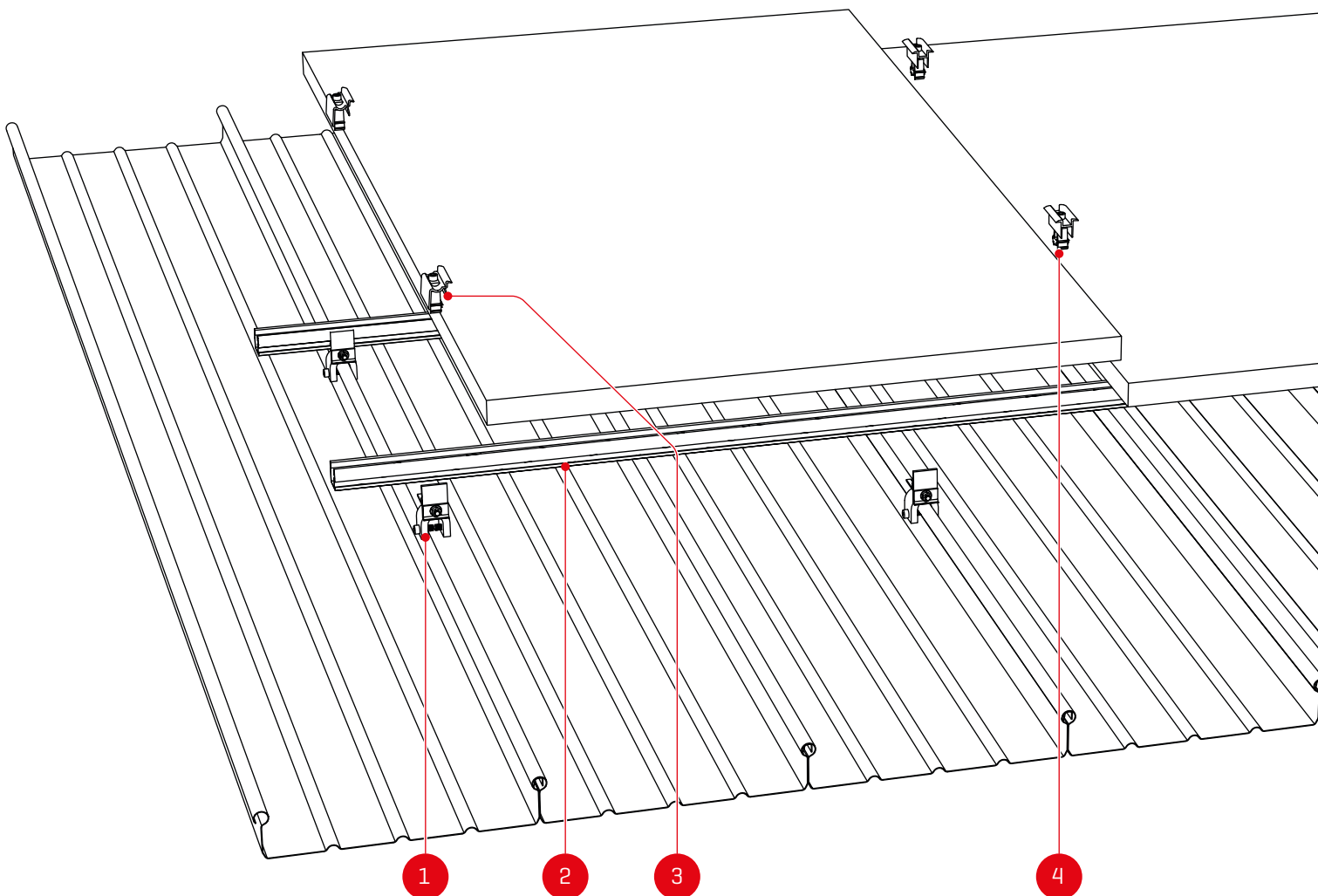

- 1 Item number system-specific
Standing seam clamps, see page 8!

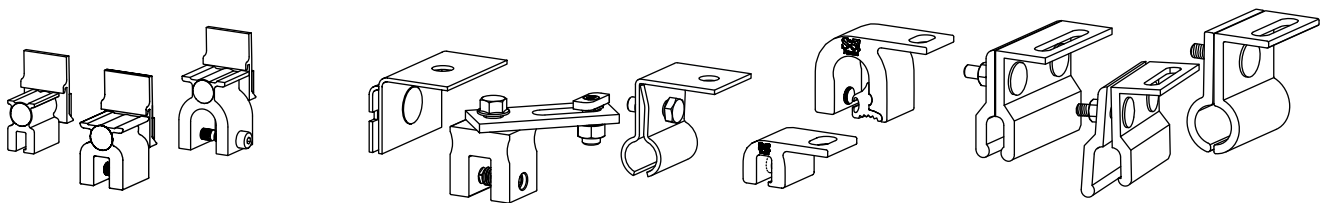

- 2 Item number system-specific
SingleRail or SolidRail and matching rail connectors

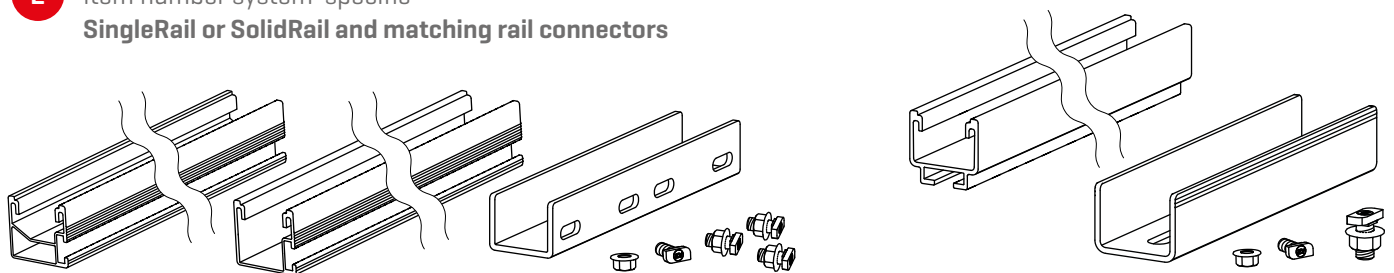

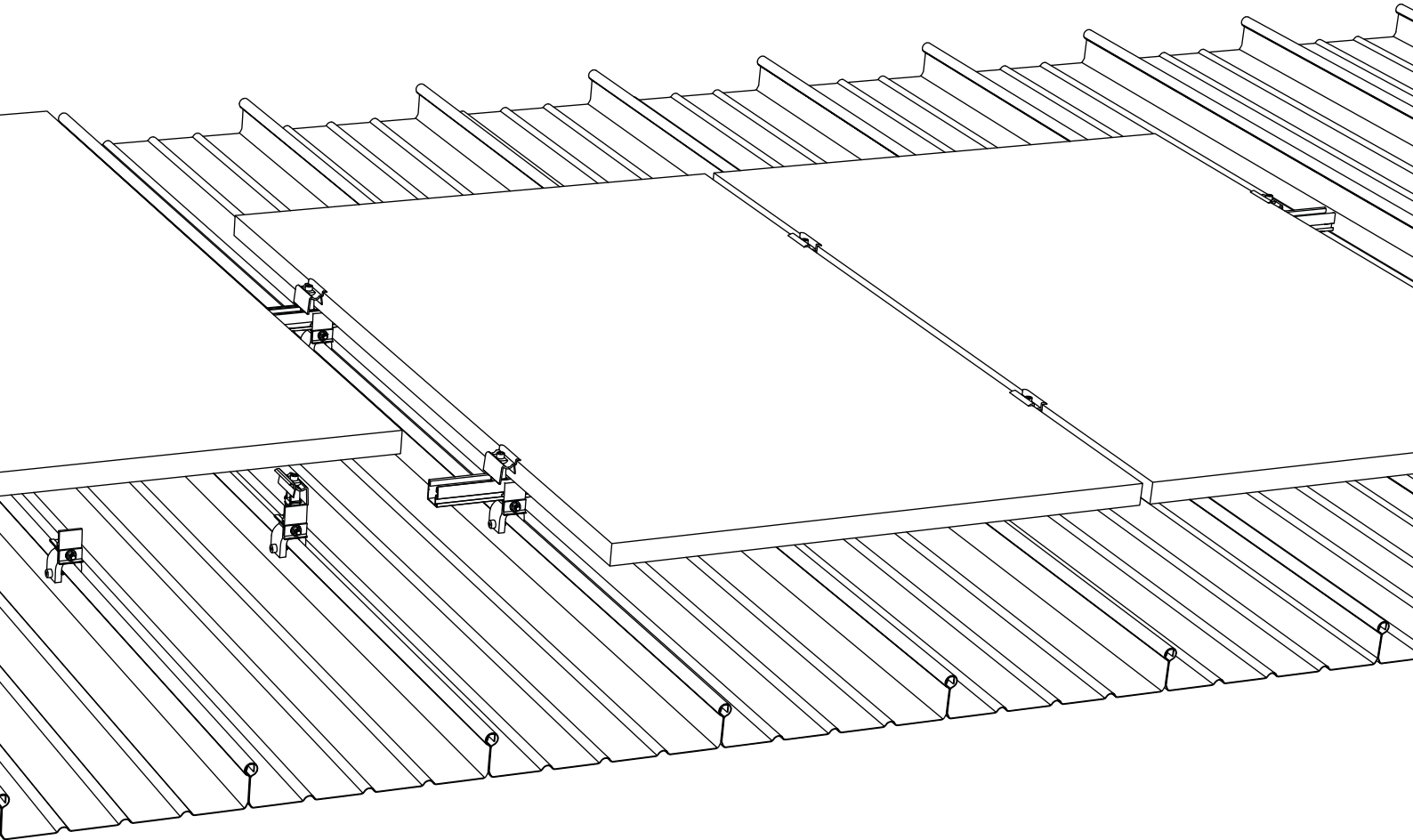

3 Item number system-specific
Module end clamps

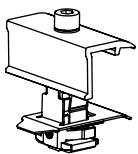

K2 Clamp EC
25 - 40



XS Clamp EC 30/33/35



OneEnd 30-42



K2 Clamp EC 30 - 40, Hybrid

4 Item number system-specific
Module middle clamps

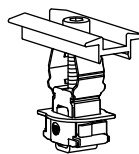

K2 Clamp MC
25 - 40



XS Clamp MC 30/33-35

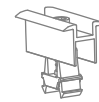

OneMid 30-42

Optional

Item number system-specific!
SolidRail connection: T-bolt and locking nut



2003145
Climber 36/50 set

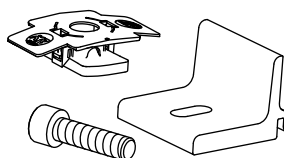

2002544
Adapter plate SolidRail

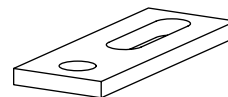

2001640
Stainless steel inlay for copper roofs

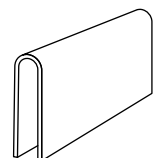

Available standing seam clamps and rail connection

Compatible with SingleRail

Single Standing SeamClamp CF:x

2003024

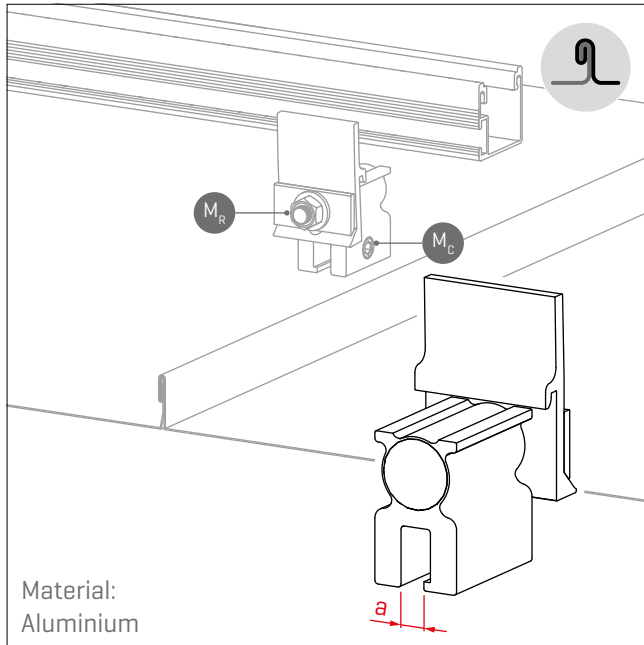

Material:
Aluminium

Seam type	Double standing seam
Sheet thickness	0.4 - 1.0 mm

$M_C = 18 \text{ Nm}$; excl. galvanised steel panel $> 0.7 \text{ mm} = 18 - 20 \text{ Nm}$
 $M_R = 15 \text{ Nm} \cdot a = 7.0 \text{ mm}$

Single Snap SeamClamp CF:x

2003083

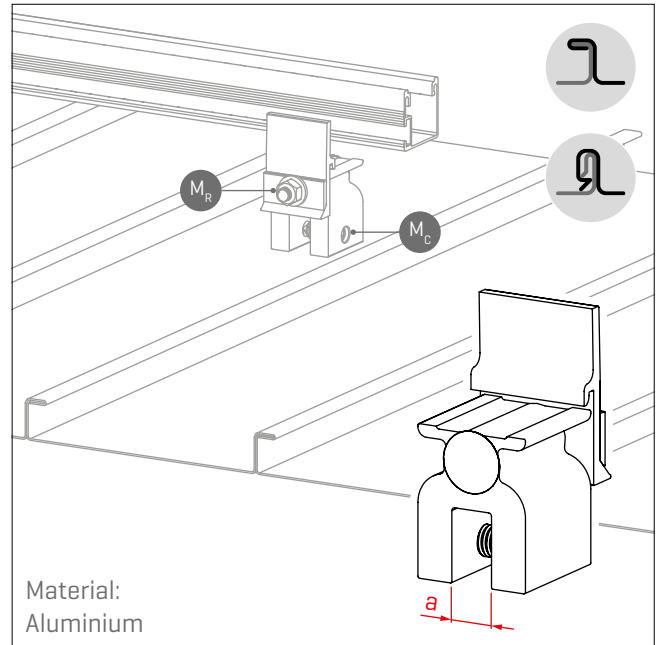

Material:
Aluminium

Seam type	Angeled and snaplock standing seam
Sheet thickness	0.4 - 1.0 mm [Steel panel $\leq 0.7 \text{ mm}$]

$M_C = 18 \text{ Nm}$; excl. galvanised steel panel $> 0.7 \text{ mm} = 18 - 20 \text{ Nm}$
 $M_R = 15 \text{ Nm} \cdot a = 14.0 \text{ mm}$

Single Round SeamClamp CF:x

2002859

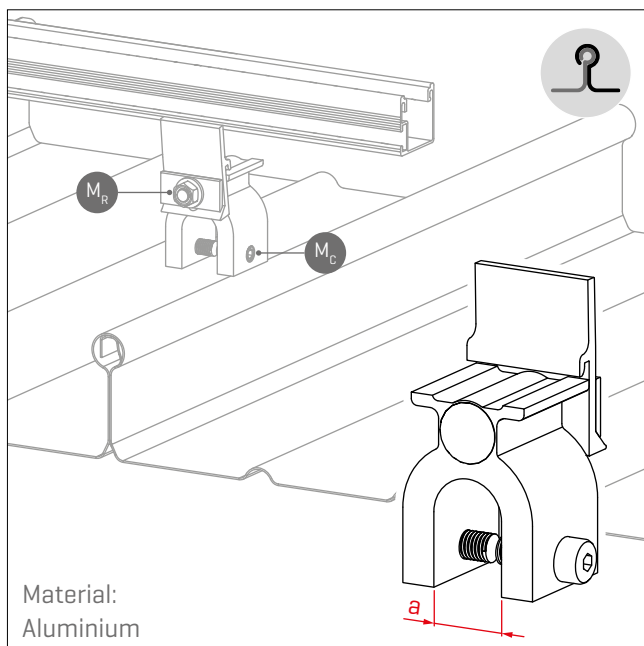

Material:
Aluminium

Seam type	Round standing seam [e.g. Bemo, Kalzip, Aluform, Rib-Roof Evolution]
Sheet thickness	0.6 - 1.2 mm

$M_C = 18 \text{ Nm} \cdot M_R = 15 \text{ Nm} \cdot a = 25.0 \text{ mm}$

Compatible with SolidRail

Solid Standing SeamClamp

2001712

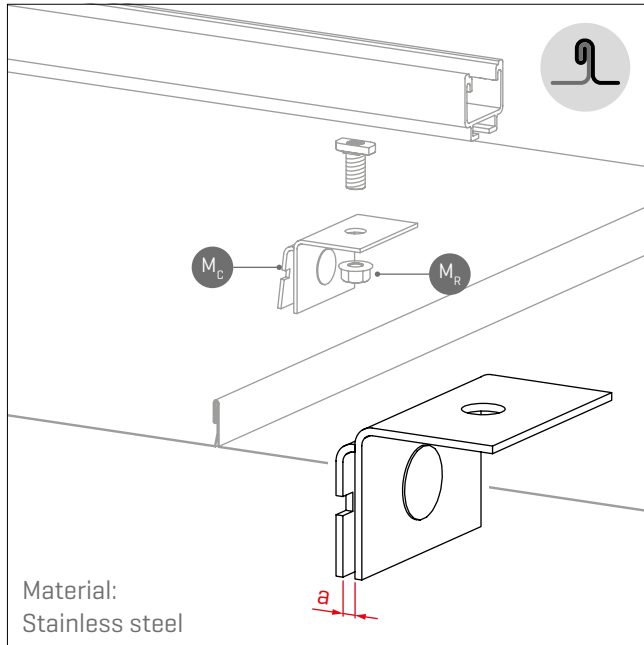

Material:
Stainless steel

Seam type	Standing seam (min. 25 mm height)
Sheet thickness	0.7 mm
Clamping range	3.5 mm

$M_C = 20 \text{ Nm} \cdot M_R = 32 \text{ Nm} \cdot a = 3.5 \text{ mm}$

Solid Snap SeamClamp CF:x

2003082

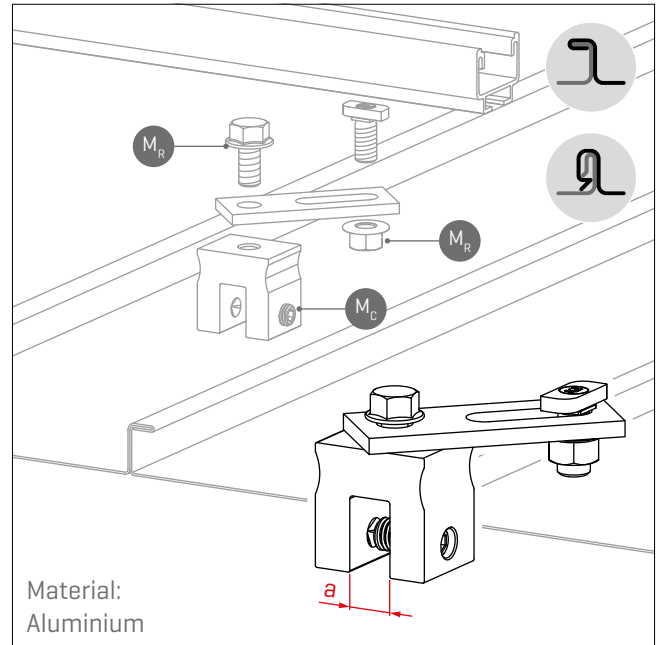

Material:
Aluminium

Seam type	Angeled and snaplock standing seam
Sheet thickness	0.4 - 1.0 mm [Steel panel $\leq 0.7 \text{ mm}$]

$M_C = 18 \text{ Nm}$; excl. alvanised steel panel $> 0.7 \text{ mm} = 18 - 20 \text{ Nm}$
 $M_R = 32 \text{ Nm} \cdot a = 14.0 \text{ mm}$

Solid Round SeamClamp

2001853

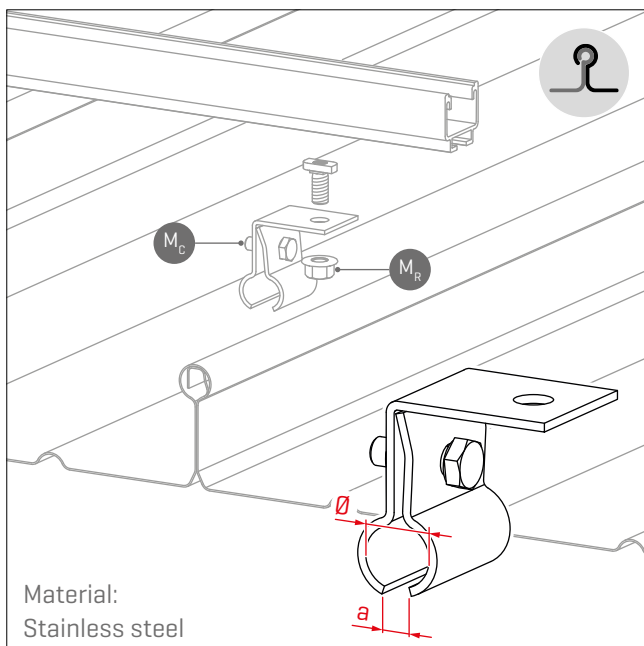

Material:
Stainless steel

Seam type	Round standing seam
Sheet thickness	$\geq 0.7 \text{ mm}$

$M_C = 20 \text{ Nm} \cdot M_R = 32 \text{ Nm} \cdot a = 10.5 \text{ mm} \cdot \text{Ø} 19.0 \text{ mm}$

S-5! Z-Mini-FL Round SeamClamp

1000888

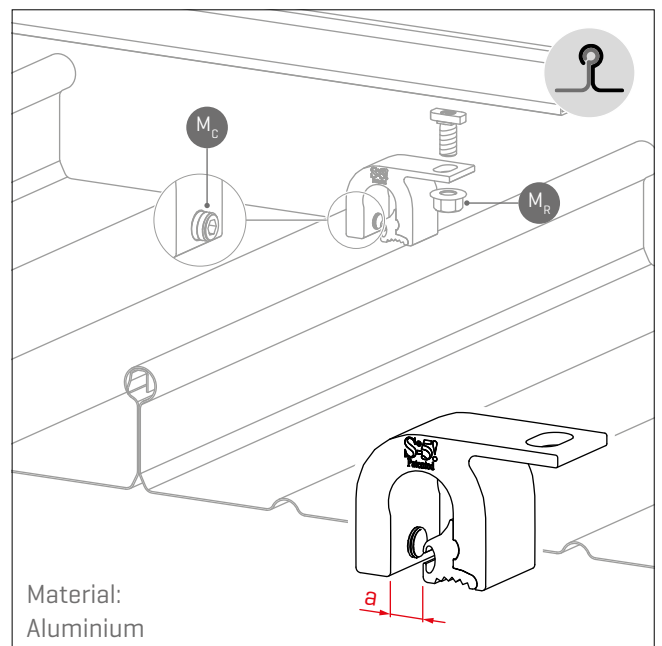

Material:
Aluminium

Seam type	Round standing seam
Sheet thickness	0.6 - 1.2 mm; Ø seam profile $\leq 23 \text{ mm}$

$M_C = 15 - 17 \text{ Nm}$; excl. galvanised steel panel $> 0.7 \text{ mm} = 18 - 20 \text{ Nm}$
 $M_R = 32 \text{ Nm} \cdot a = 11.5 \text{ mm}$

Compatible with SolidRail

S-5! E-Mini-FL Standing SeamClamp 1001052

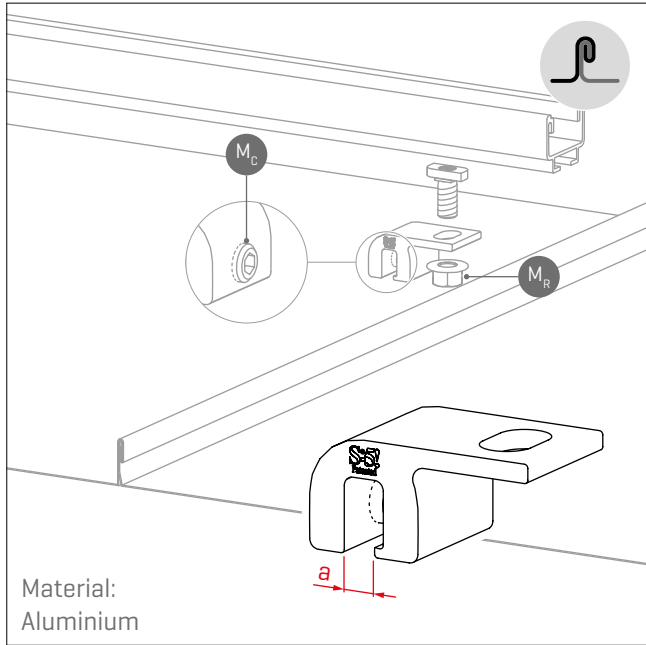

Seam type	Double standing seam
Sheet thickness	0.4 - 1.0 mm

$M_C = 15 - 17 \text{ Nm}$; excl. galvanised steel panel $> 0.7 \text{ mm} = 18 - 20 \text{ Nm}$
 $M_R = 32 \text{ Nm} \cdot a = 7.0 \text{ mm}$

Rib-Roof 465 Clamp 2002118

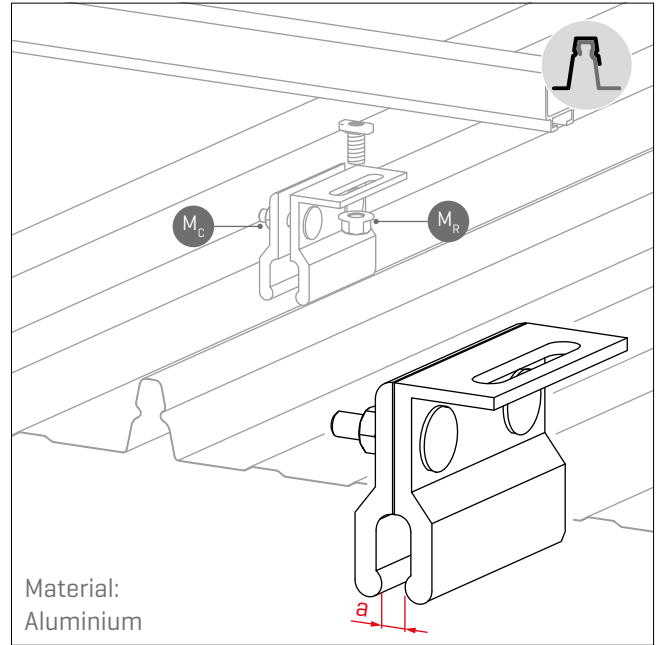

Seam type	Rib-Roof 465
------------------	--------------

$M_C = 20 \text{ Nm} \cdot M_R = 32 \text{ Nm} \cdot a = 12.0 \text{ mm}$

Always mount on the overlap rib! A minimum distance of 50 mm plus length expansion (approx. 100 - 200 mm) to the retaining brackets must be maintained to ensure the length expansion of the profiled sheets.

Rib-Roof Speed 500 Clamp 2002225

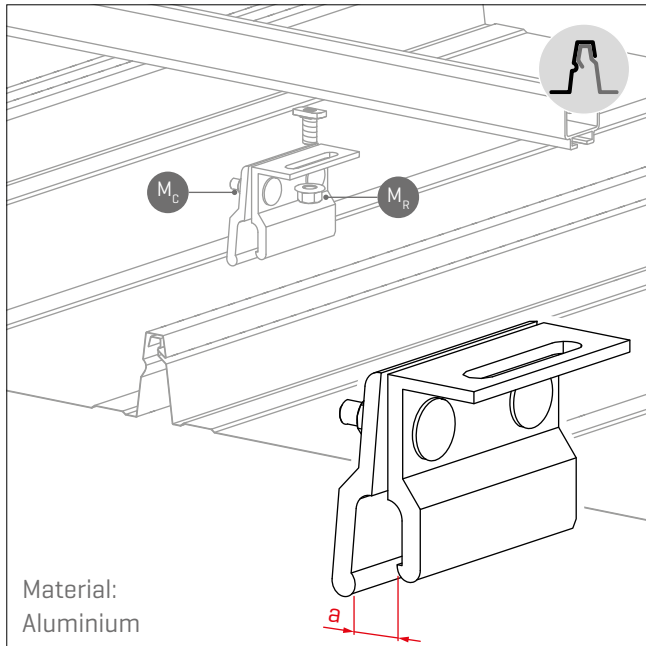

Seam type	Rib-Roof Speed 500 *
------------------	----------------------

$M_C = 20 \text{ Nm} \cdot M_R = 32 \text{ Nm} \cdot a = 17.0 \text{ mm}$

Rib-Roof Evolution Clamp 2002226

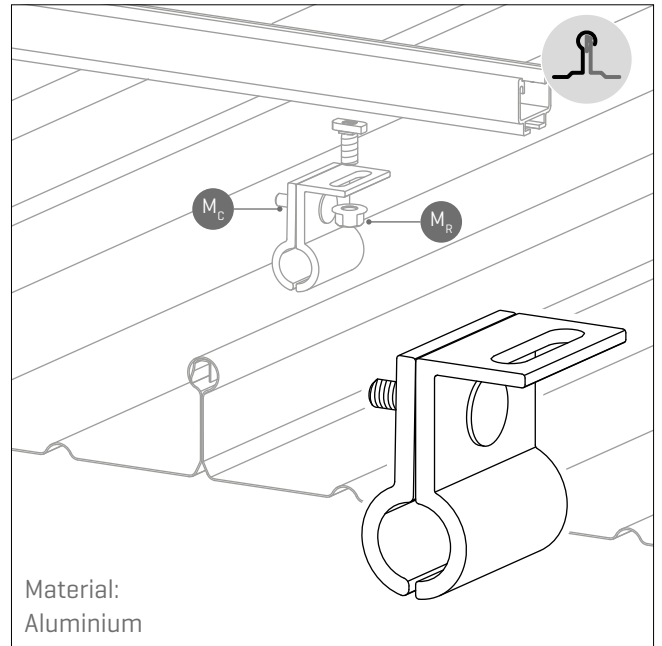

Seam type	Rib-Roof Evolution
------------------	--------------------

$M_C = 20 \text{ Nm} \cdot M_R = 32 \text{ Nm} \cdot \varnothing 23.0 \text{ mm}$

* From delivery year 2005; older roofs on request



Assembly

Basic assembly

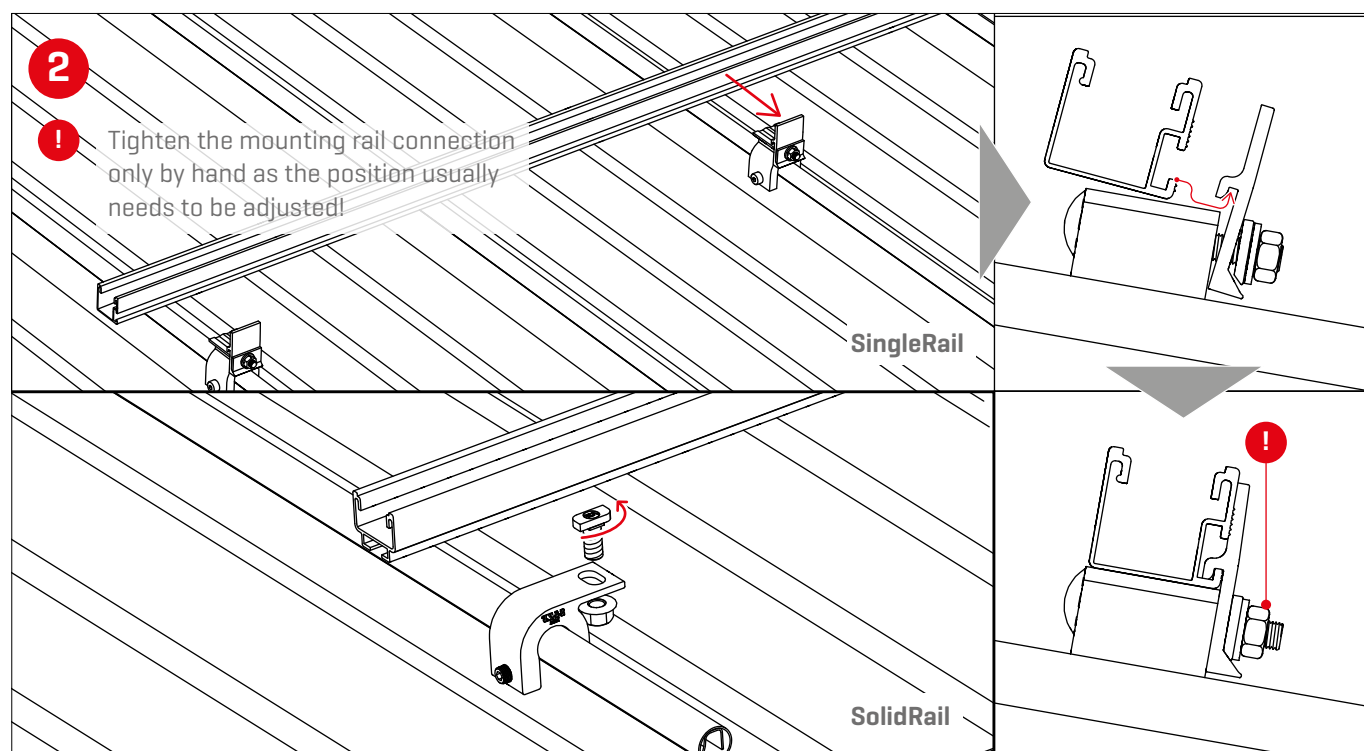
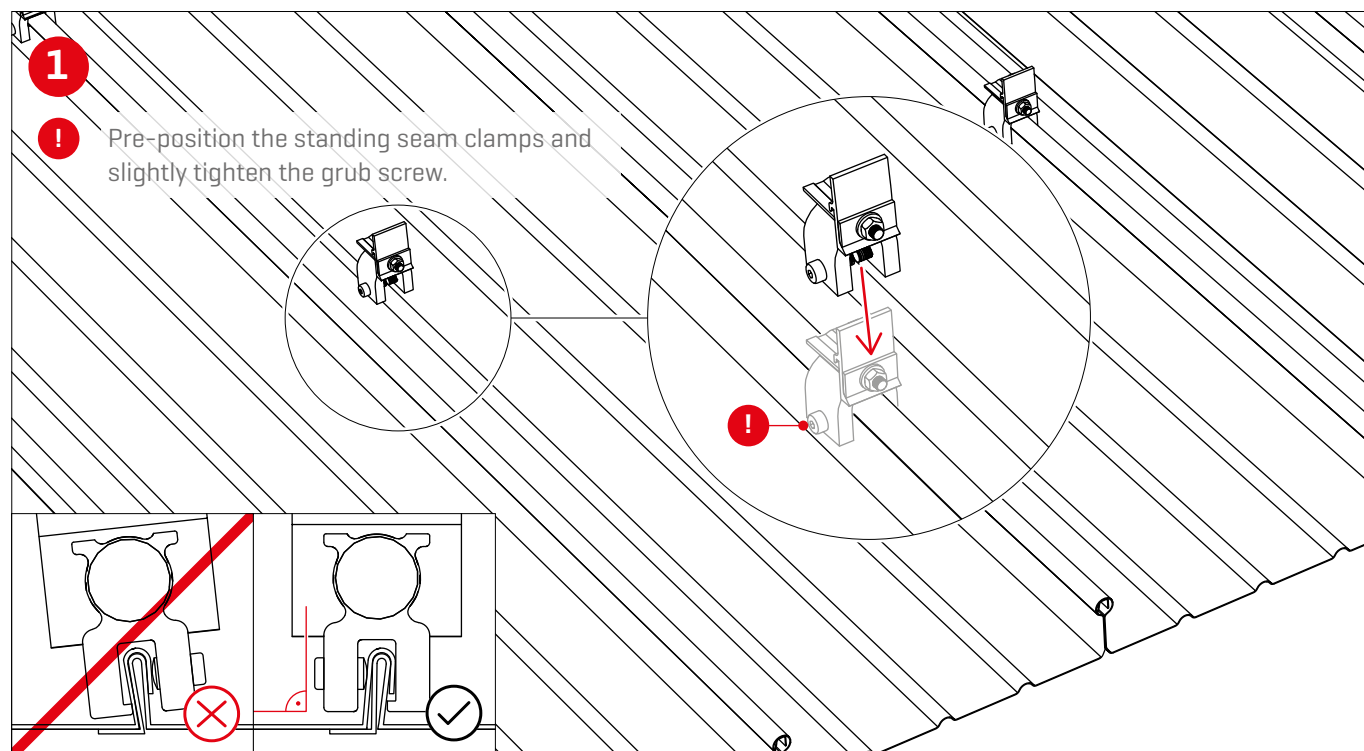

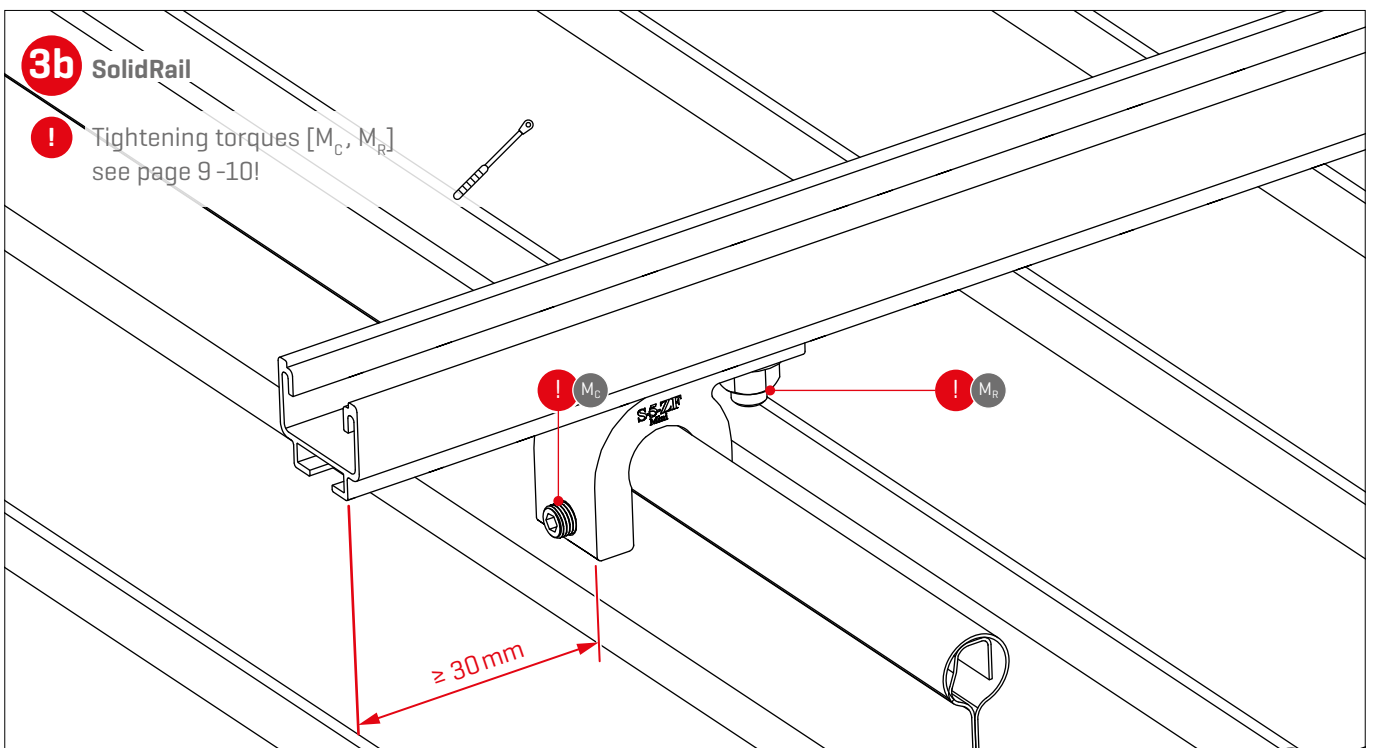
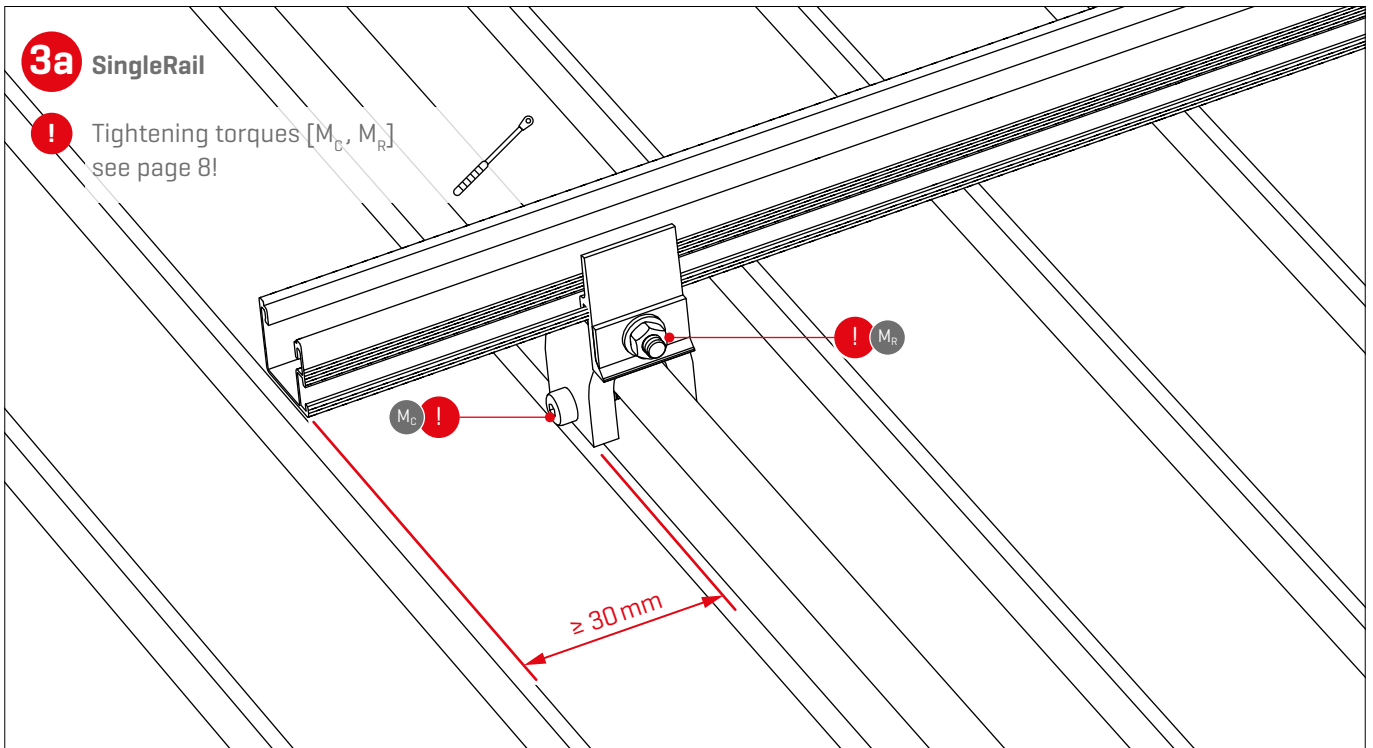

Portrait: 1 rail position

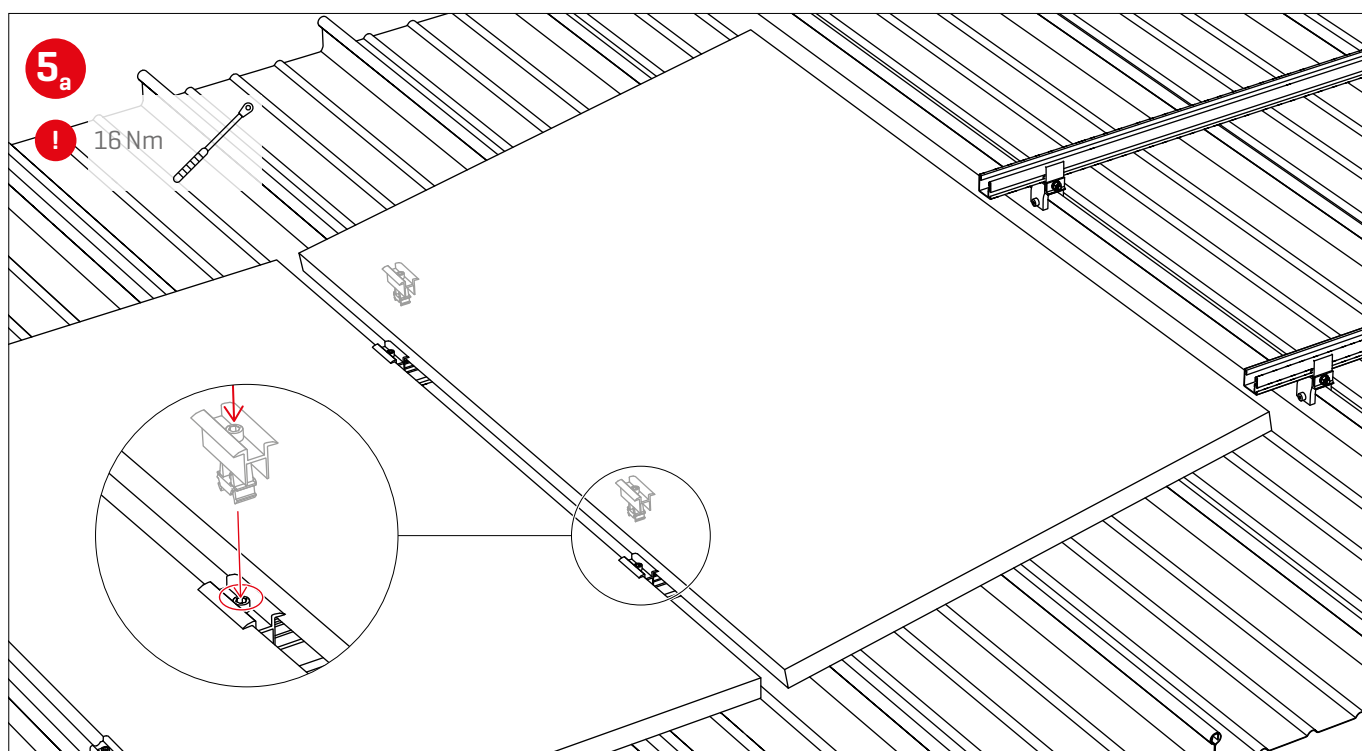
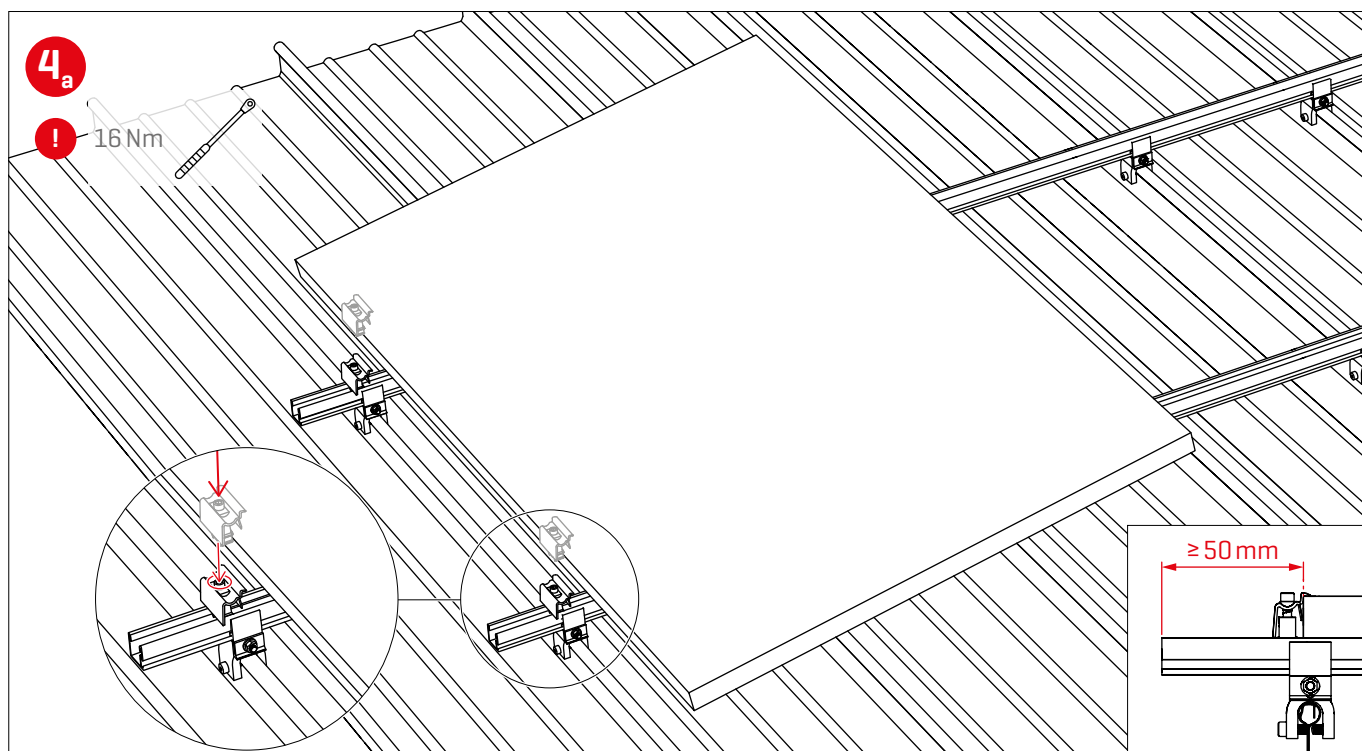

Landscape: 2 rail positions, clamping of long module edge

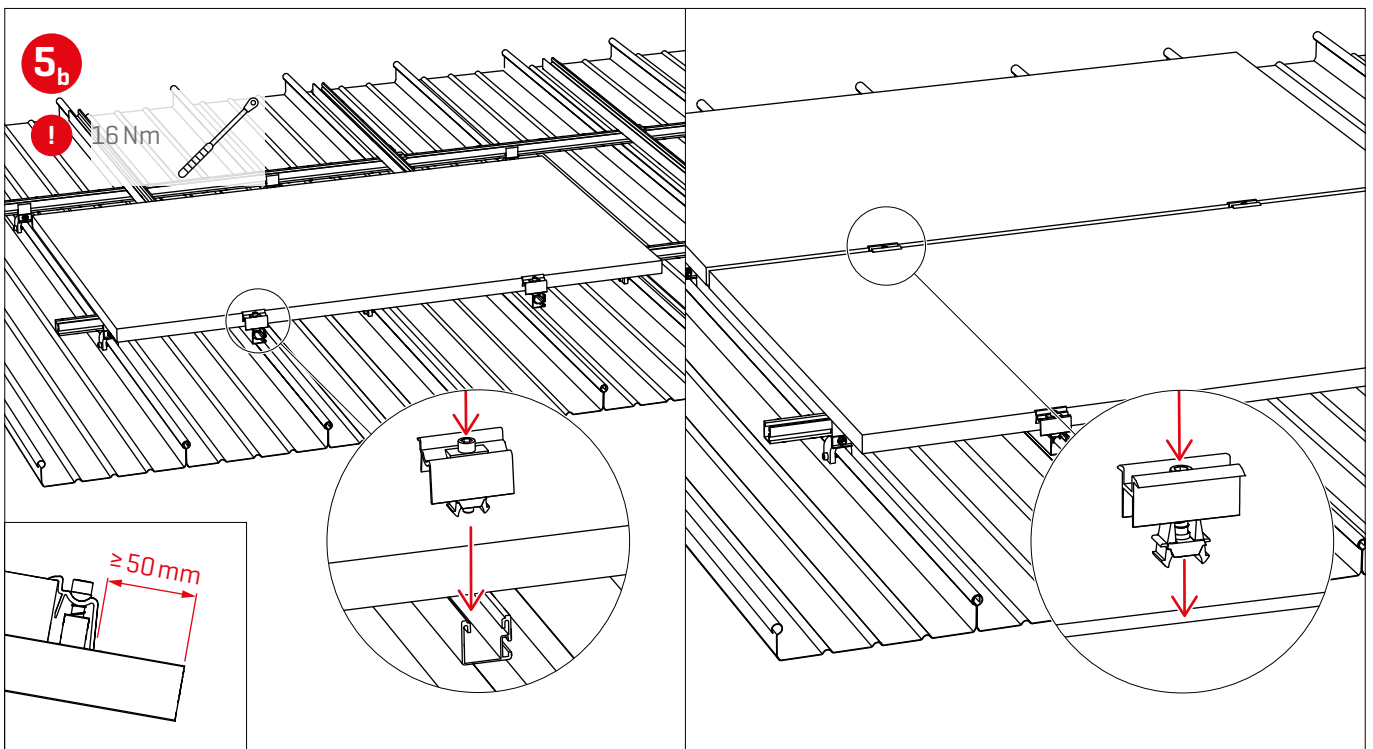
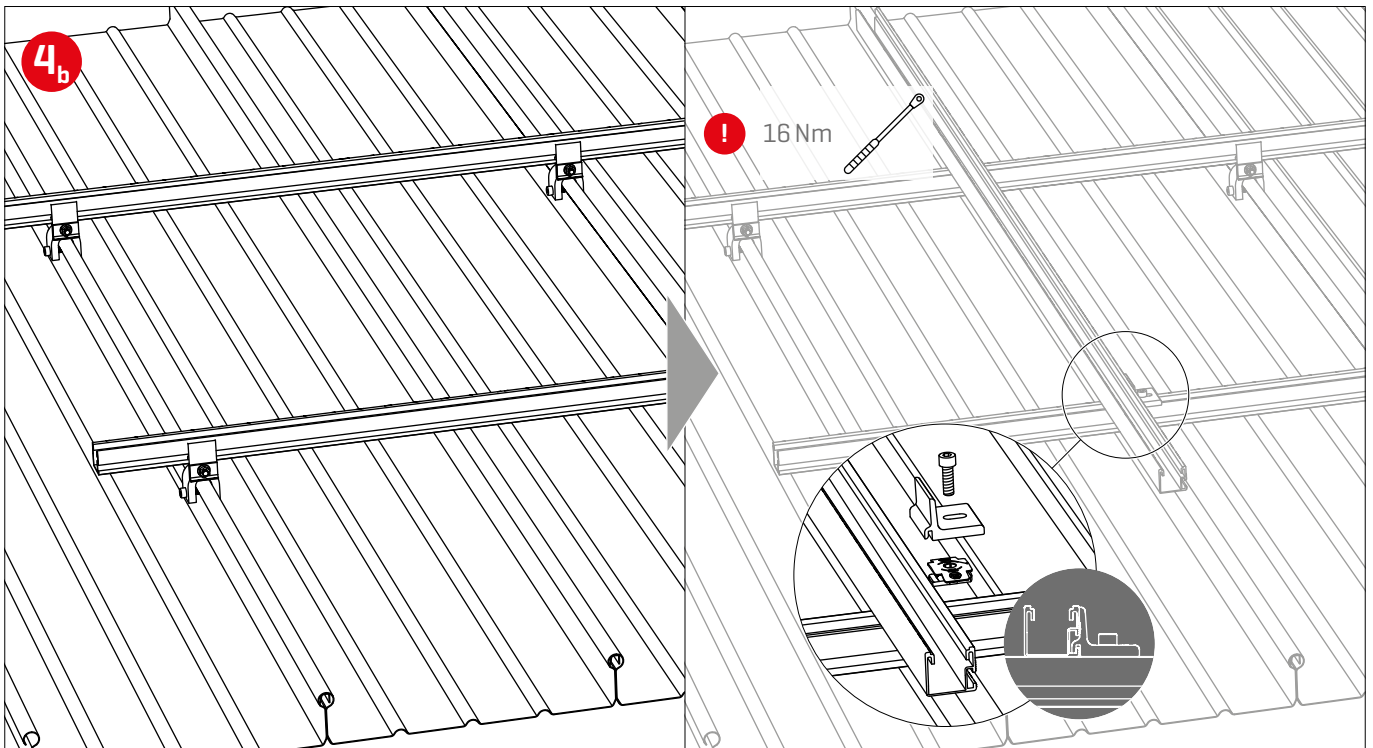

Landscape: 1 rail position, clamping of short module edge

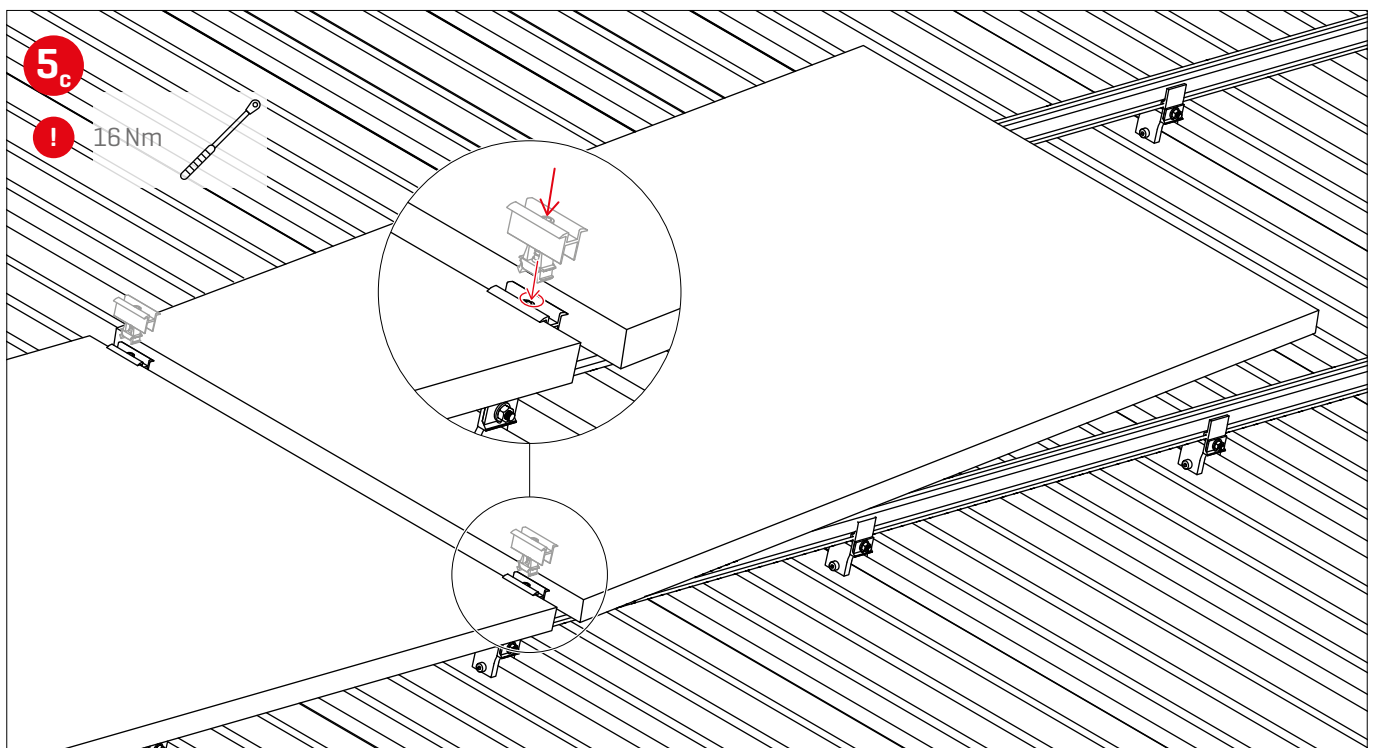
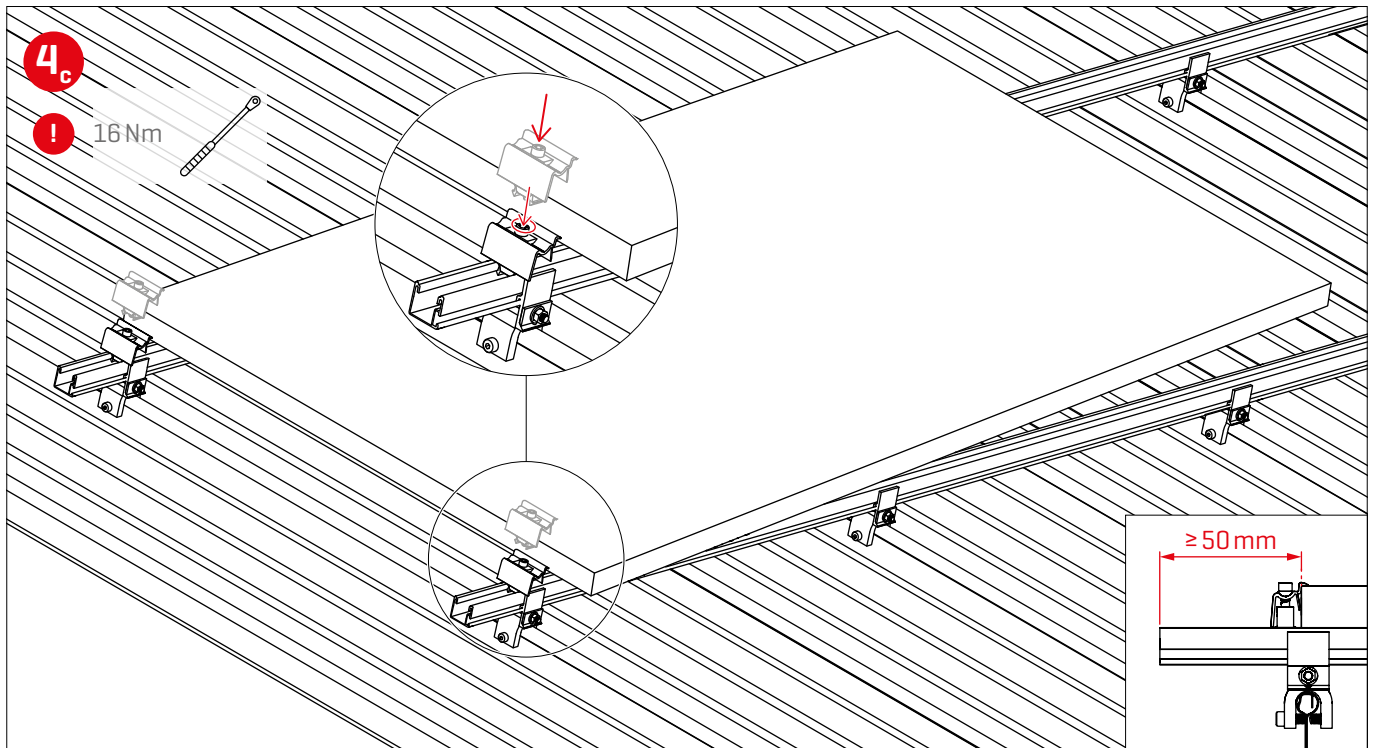

Thermal separations

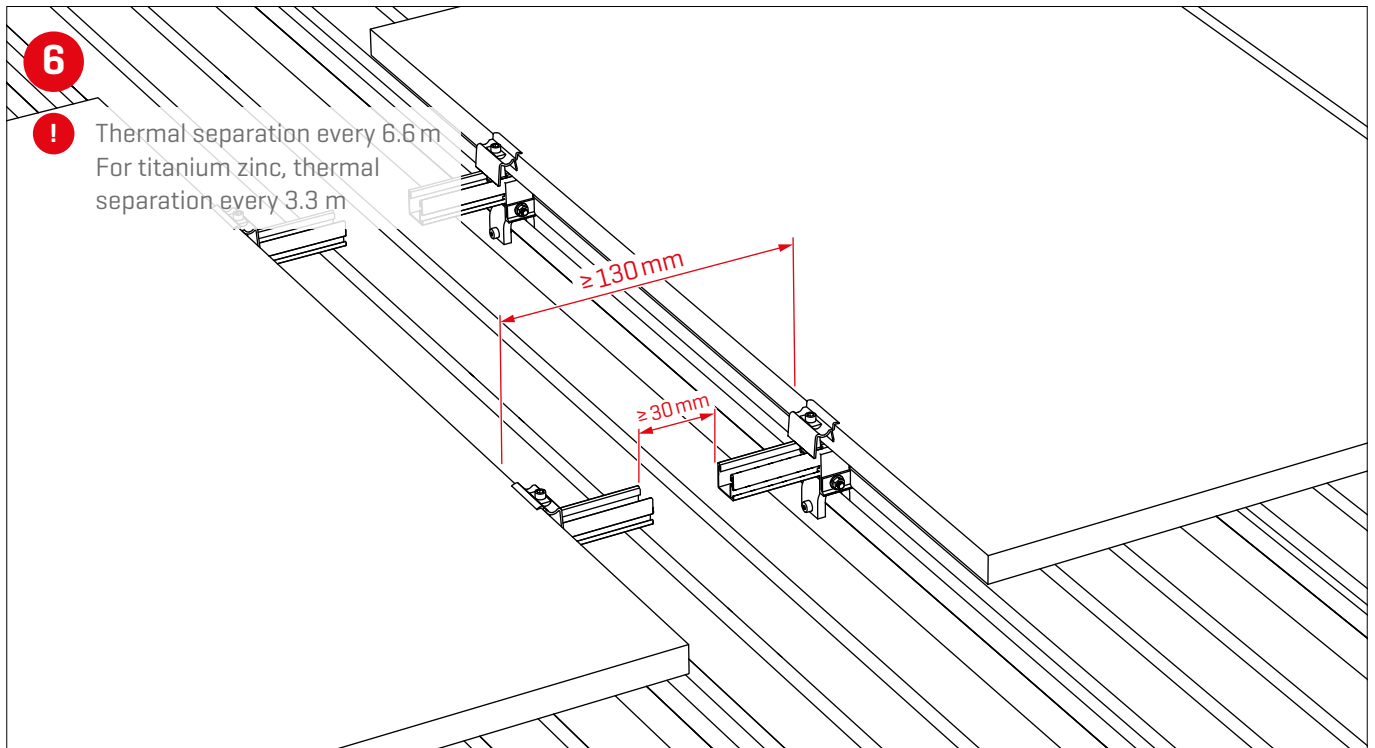

Notes

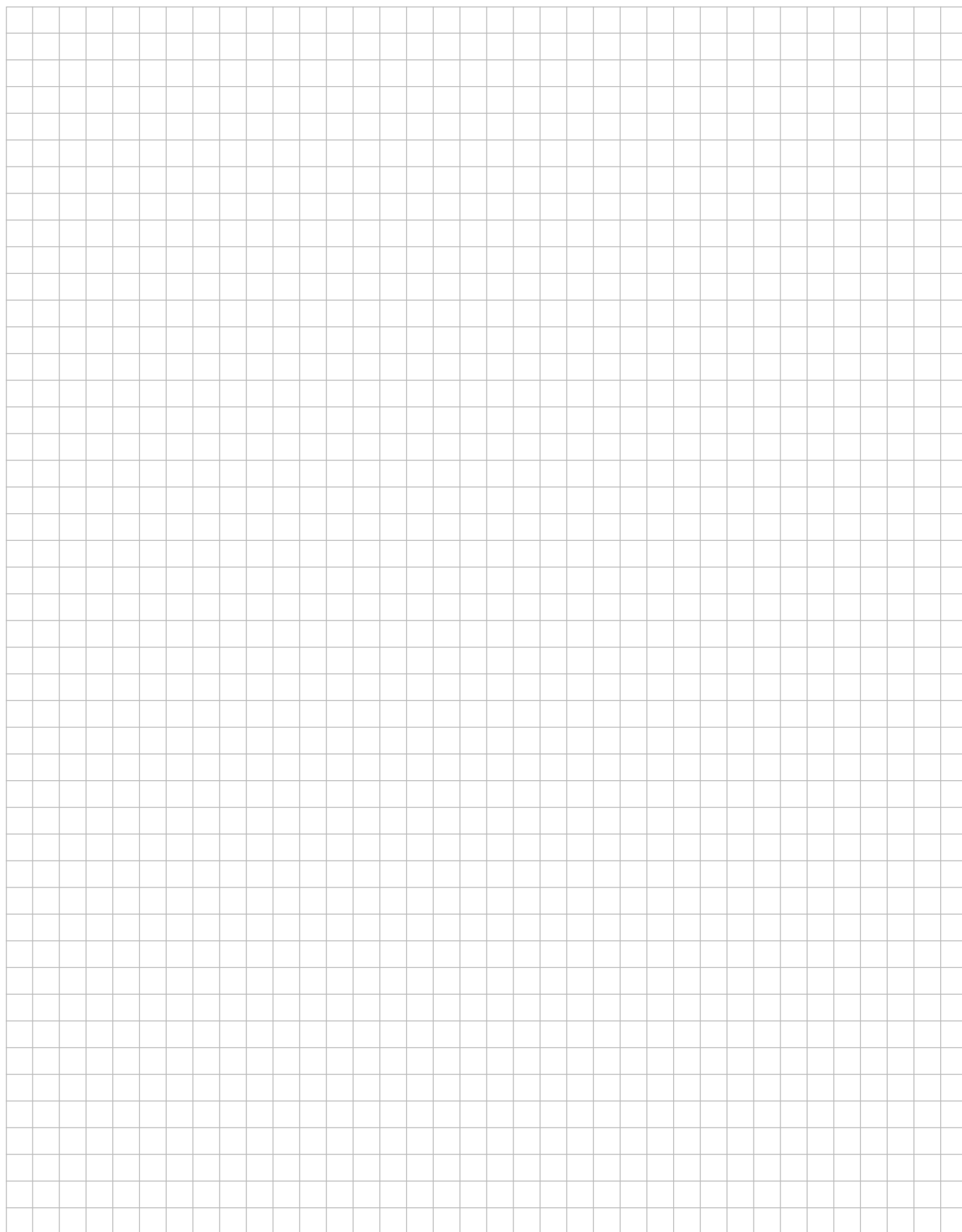

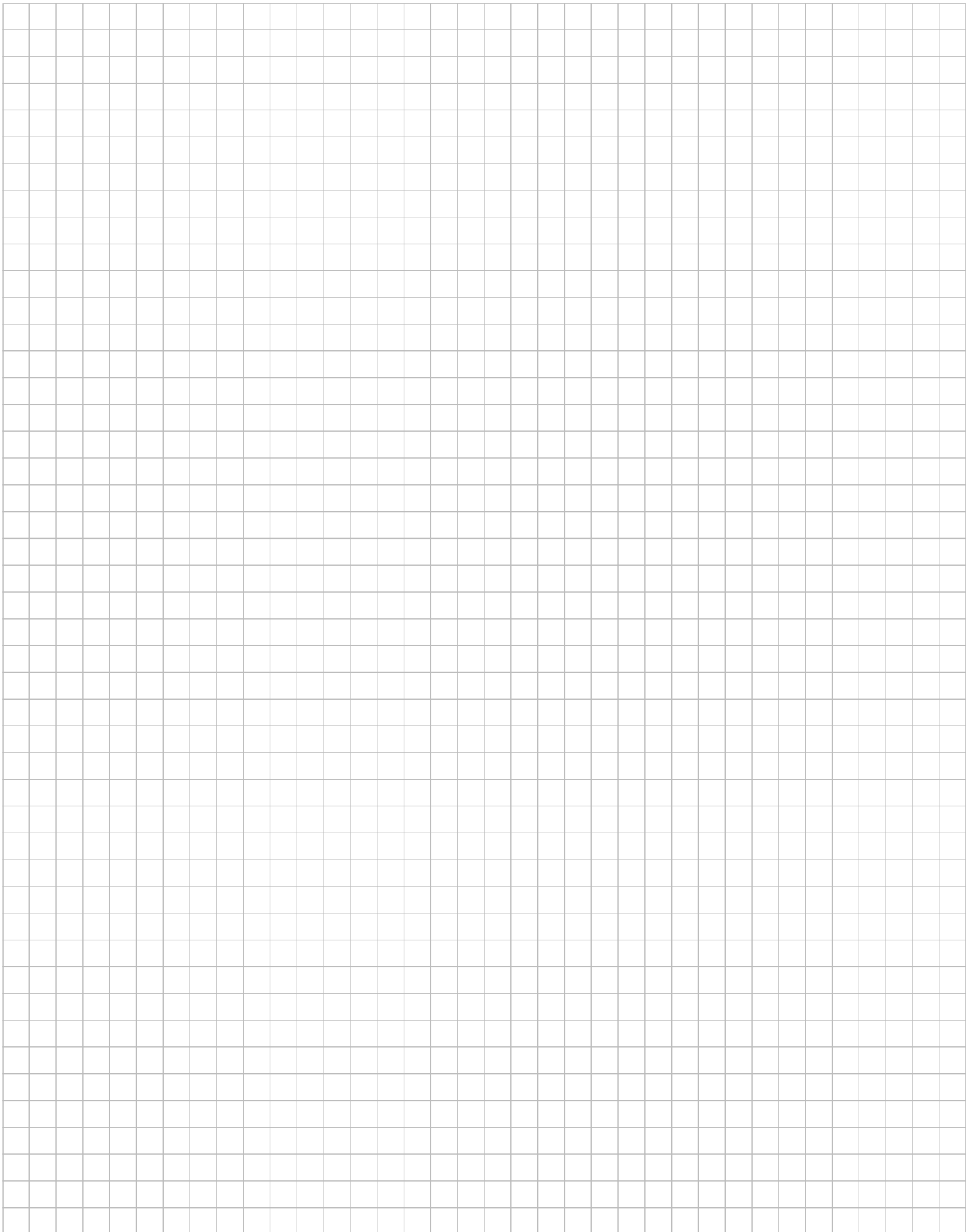

We support PV systems



Thank you for choosing a K2 mounting system.

Systems from K2 Systems are quick and easy to install. We hope these instructions have helped. Please contact us with any questions or suggestions for improvement. Our contact data:

- ▶ www.k2-systems.com/en/contact
- ▶ **Service-Hotline: +49 (0)7159 42059-0**

Our General Terms of Business apply. Please refer:
www.k2-systems.com

K2 Systems GmbH
Haldenstraße 1
71272 Renningen
Germany
+49 (0) 7159 - 42059 - 0
info@k2-systems.com
www.k2-systems.com