

Wiring a Split Charge Relay

Midsummer Energy

Important: ensure that both battery banks and the alternator share a common negative connection. If not, run substantial cables to connect the negatives.

Existing wiring not shown for clarity.

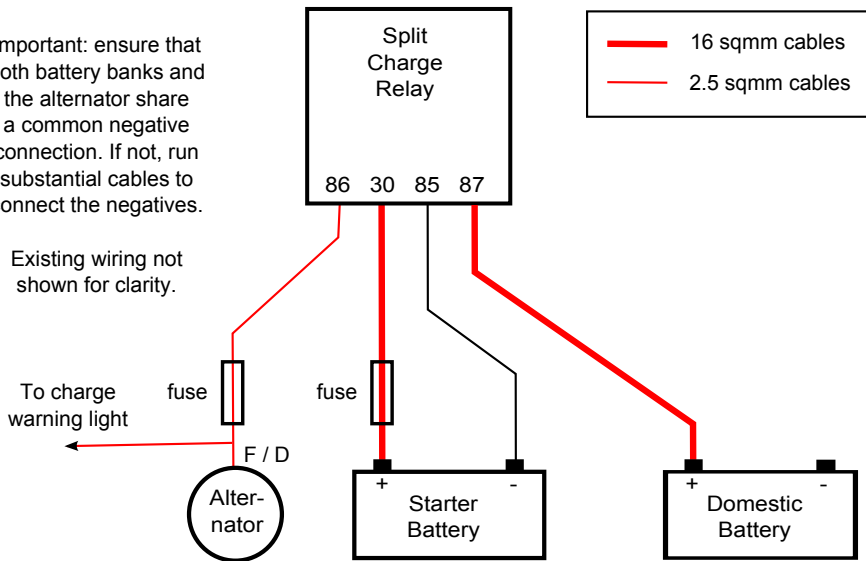

To fit a split charge relay, first connect a 16sqmm red cable from the positive terminals of each battery bank to the large studs on the relay labelled '87' and '30'. Ensure this cable is thick enough to carry the maximum charging current of your alternator. Fit a fuse to one of these cables rated no higher than the cables or the relay.

Next run a 2.5 sqmm red cable from the small spade terminal on your alternator marked 'F' or 'D' to terminal 85 on the split charge relay (this is the same terminal that will be connected to your charge warning light - don't disconnect the warning light though!). This cable should also be fused at no more than 5A.

Finally run a 2.5sqmm black cable from terminal 86 to any convenient negative.

When the alternator is producing output, the relay will close connecting the two battery banks together and allowing them both to charge.

The disadvantage to using a split charge relay over other more sophisticated solutions is that it does not prevent a very flat secondary bank from draining your main bank when the engine is running. If your secondary bank is very low ensure the engine is run for long enough to charge all batteries to a good level before switching off.