

solaredge

SolarEdge

Home Energy Management ZigBee Card Installation Guide

Europe & APAC
Version 1.2

Revision History

- Version 1.2 (Nov. 2017)
 - Terminology change:
 - Home Energy Management
 - AC Switch with Metering
 - Up to 6 devices inter-connected in a master-slave configuration
 - Addition of step: make sure the inverter/ CCG is turned OFF before card installation
 - Addition of LCD menu item - RS485-2
 - Updated images
 - Updated Contact information
- Version 1.1 (Apr. 2017) - language editing; no content change
- Version 1.0 (Jul. 2016) - First release

Disclaimers

Important Notice

Copyright © SolarEdge Inc. All rights reserved.

No part of this document may be reproduced, stored in a retrieval system or transmitted, in any form or by any means, electronic, mechanical, photographic, magnetic or otherwise, without the prior written permission of SolarEdge Inc.

The material furnished in this document is believed to be accurate and reliable. However, SolarEdge assumes no responsibility for the use of this material. SolarEdge reserves the right to make changes to the material at any time and without notice. You may refer to the SolarEdge web site (www.solaredge.com<http://www.solaredge.us>) for the most updated version.

All company and brand products and service names are trademarks or registered trademarks of their respective holders.

Patent marking notice: see <http://www.solaredge.com/patent>

The general terms and conditions of delivery of SolarEdge shall apply.

The content of these documents is continually reviewed and amended, where necessary. However, discrepancies cannot be excluded. No guarantee is made for the completeness of these documents.

The images contained in this document are for illustrative purposes only and may vary depending on product models.

Emission Compliance

This equipment has been tested and found to comply with the limits applied by the local regulations. These limits are designed to provide reasonable protection against harmful interference in a residential installation. This equipment generates, uses and can radiate radio frequency energy and, if not installed and used in accordance with the instructions, may cause harmful interference to radio communications. However, there is no

guarantee that interference will not occur in a particular installation. If this equipment does cause harmful interference to radio or television reception, which can be determined by turning the equipment off and on, you are encouraged to try to correct the interference by one or more of the following measures:

- Reorient or relocate the receiving antenna.
- Increase the separation between the equipment and the receiver.
- Connect the equipment into an outlet on a circuit different from that to which the receiver is connected.
- Consult the dealer or an experienced radio/TV technician for help.

Changes or modifications not expressly approved by the party responsible for compliance may void the user's authority to operate the equipment.

Contents

Disclaimers	1
Important Notice	1
Emission Compliance	1
Contents	3
Support and Contact Information	4
About This Guide	6
Chapter 1: Overview	7
Package Contents	7
Chapter 2: Installing the ZigBee Card and Antenna	8
Installing the Antenna and Cable	8
Mounting the ZigBee Card in the Inverter	11
Chapter 3: Configuring ZigBee Communication	13
Appendix A: Technical Specifications	19

Support and Contact Information

If you have technical problems concerning SolarEdge products, please contact us:

Country	Phone	E-Mail
Australia (+61)	1800 465 567	support@solaredge.net.au
APAC (Asia Pacific) (+972)	073 240 3118	support-asia@solaredge.com
Benelux	NL: 0800-7105	support@solaredge.nl
	BE: 0800-76633	support@solaredge.be
China (+86)	21 6212 5536	support_china@solaredge.com
DACH & Rest of Europe (+49)	089 454 59730	support@solaredge.de
France (+33)	0800 917410	support@solaredge.fr
Italy (+39)	0422 053700	support@solaredge.it
Japan (+81)	03 6262 1223	support@solaredge.jp
Netherlands (+31)	0800 0221 089	support@solaredge.nl
New Zealand (+64)	0800 144 875	support@solaredge.net.au
US & Canada (+1)	510 498 3200	ussupport@solaredge.com
United Kingdom (+44)	0800 028 1183	support-uk@solaredge.com
Greece (+49)	89 454 59730	support@solaredge.com
Israel (+972)	073 240 3122	
Middle East & Africa (+972)	073 240 3118	
South Africa (+27)	0800 982 659	
Turkey (+90)	216 706 1929	
Worldwide (+972)	073 240 3118	

Before contact, make sure to have the following information at hand:

- Model and serial number of the product in question.
- The error indicated on the Application screen or on the SolarEdge monitoring platform or by the LED, if there is such an indication.
- System configuration information, including the type and number of modules connected and the number and length of strings.
- The communication method to the SolarEdge server, if the site is connected.
- The software version as appears in the ID status screen.

About This Guide

This user guide is intended for Photovoltaic (PV) system owners, installers, technicians, maintainers, and integrators who use the SolarEdge power harvesting system.

This manual describes how to install and set up the Device Control ZigBee™ card for Device Control network management.

This guide assumes that the SolarEdge power harvesting system is already installed and commissioned. For additional information about how to install and commission the SolarEdge power harvesting system, refer to the relevant installation guide.

This guide includes the following chapters:

- *Overview* on page 7, describes the SolarEdge Wi-Fi card functionality and connection.
- *Installing the ZigBee Card and Antenna* on page 8 describes how to mount, connect and verify the connection of the Wi-Fi card.
- *Configuring ZigBee Communication* on page 13 describes how to set up the Device Control network manager.
- *Technical Specifications* on page 19 provides the electrical and mechanical specifications of the Device Control ZigBee card.

For further information, datasheets and the most up-to-date certifications for various products in different countries, please visit the SolarEdge website:

www.solaredge.com.

Chapter 1: Overview

ZigBee is an open global standard for wireless technology designed to use low-power digital radio signals for personal area networks. ZigBee is used for connection between several SolarEdge devices. Home Energy Management uses the ZigBee Home Automation protocol with up to 6 devices interconnected in a master-slave configuration where the Home Energy Management ZigBee card is the master.

Home Energy Management products include:

- Immersion Heater Controller
- Plug-In Socket with Metering
- AC Switch with Metering
- Dry Contact Switch

Package Contents

- Home Energy Management ZigBee Card
- Antenna
- Mounting clip with RF cable
- Activation card
- This installation guide



NOTE

This ZigBee card is for Home Energy Management only and cannot be used for communications to the monitoring platform.

Chapter 2: Installing the ZigBee Card and Antenna

Install the card in the inverter which will act as the Home Energy Management network manager.

Installing the Antenna and Cable

1. Connect the antenna to the mounting clip.



Figure 1: Connecting the antenna to the mounting clip

2. Attach the mounting clip with the antenna vertically to the top of the inverter. You may attach the clip to the heat sink fins or the inverter side.

Single phase/ three phase inverters

HD-Wave inverter

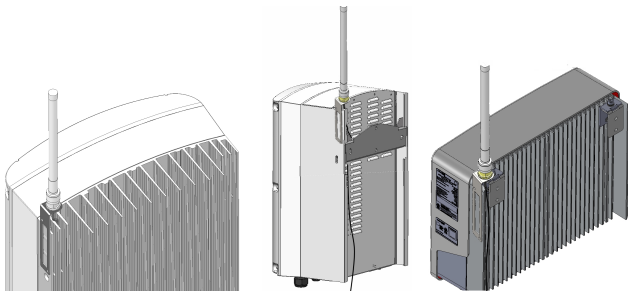

Figure 2: Single phase/ three phase and HD-Wave inverters

3. If not mounting the antenna on the inverter top, install the clip on the wall using two screws (not supplied). The antenna must be vertical and far from metal surfaces (including the inverter side).

4. Route the antenna cable along the inner fins or the inverter side, in the bracket. Make sure the cable is not hanging loose outside the inverter enclosure.

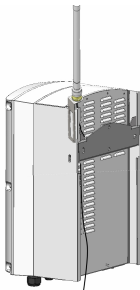

Figure 3: Routing the antenna cable (Three phase inverter)

5. Disconnect the AC power to the inverter and wait 5 minutes.
6. Open the inverter cover as described in the appropriate manual.

- Open the communication gland numbered 1 at the bottom of the inverter.

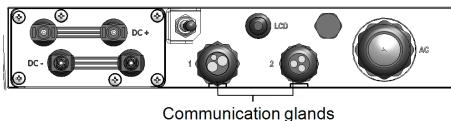

Figure 4: Single phase/ three phase inverter sealing glands

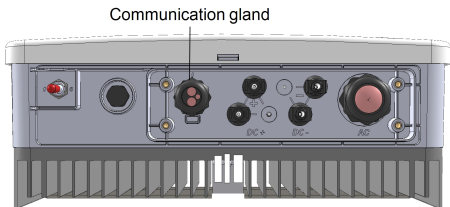

Figure 5: HD-Wave inverter communication gland

- Remove the plastic seal from the *small* opening .
- Remove the rubber fitting from the gland and insert the RF cable through the gland cover and the opened connection of the inverter.
- Push the cable into the cut opening of the rubber fitting.

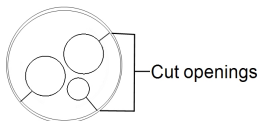

Figure 6: Rubber fitting

- Insert the rubber seal with the cable into to the gland body and reconnect the gland to the inverter. Tighten the sealing gland.

12. Insert the excess of cable length into the inverter until the cable can be tightly attached to the inverter side.

Mounting the ZigBee Card in the Inverter

1. Check the card part number and verify you are using the Home Energy Management ZigBee Card (and not the Home Gateway ZigBee Card).
2. Turn OFF the inverter ON/OFF switch, the safety switch (if applicable) and the AC circuit breaker on the main AC distribution panel.
3. Connect the ZigBee card in its place on the communication board, as shown in *Figure 8*.
4. Follow these guidelines:
 - Use the marking on the communication board to plug in the ZigBee card with the correct orientation.
 - Insert the ZigBee card such that all pins are correctly positioned in the communication board socket, and no pins are left out of their socket.
 - Make sure that the card is firmly in place.
5. Install the two cable holders on the communication board.
6. Route the cable towards the ZigBee card while snapping it into the two cable holders at the side of the communication board.

7. Connect the RF cable to the ZigBee card and tighten manually.

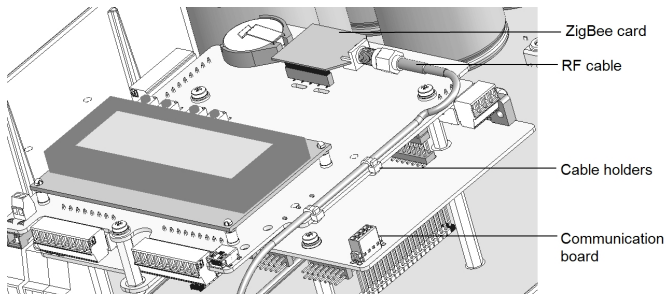

Figure 7: ZigBee and RF cable on the single/three phase inverter communication board

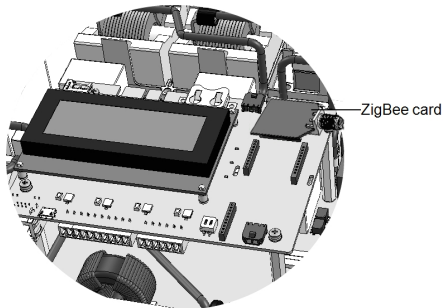

Figure 8: ZigBee on HD-Wave inverter communication board

8. Close the SolarEdge inverter cover as described in the inverter installation guide. Check for proper cover fastening to ensure sealing.
9. Turn ON AC power to the inverter.
10. Turn the inverter ON/OFF switch to ON.

Chapter 3: Configuring ZigBee Communication

Communication

This section describes, how to upgrade the inverter software in 1Ph/3Ph inverters and in HD-Wave inverters, ZigBee communication configuration in 1Ph/3Ph inverters and in HD-Wave inverters.

► To upgrade the inverter software:

1. Disconnect the AC power to the inverter and wait 5 minutes.
2. Open the inverter cover as described in its manual.
3. Insert the firmware upgrade card supplied with the kit into the card slot on the communication board.

SolarEdge 1Ph/3Ph inverters

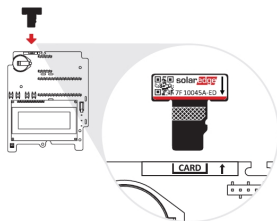

SolarEdge 1Ph inverter (HD-Wave)

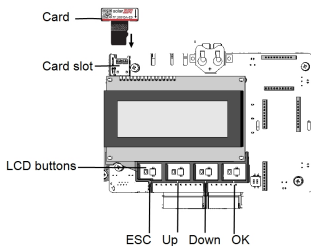

Figure 9: Communication board and activation card

4. Turn the AC ON.



WARNING!

ELECTRICAL SHOCK HAZARD. Do not touch uninsulated wires when the cover is removed.

5. If upgrade is required, it starts automatically. Wait for the message "Done" to be displayed on the LCD.
6. Verify the correct version as described above.
7. Remove the card from the inverter.

▶ **To configure ZigBee in 1Ph/3Ph inverters using the LCD light button:**

Use the LCD button to toggle through the informative status screens, and for communication setup.

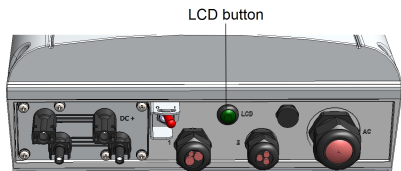

Figure 10: Inverter connector panel

1. Verify that the inverter ON/OFF switch is OFF.
2. Press the LCD Light button once to turn ON the back light. If the inverter worked properly before this action, the following message is displayed:

```
DC VOLTAGE NOT SAFE
DO NOT DISCONNECT
VDC : 72.0
```

This message is displayed until the DC is below the safety voltage threshold. The default safety voltage is 50 V.

3. Access the Setup mode: Press and hold down the LCD button until the following message is displayed:

```
Keep holding button
for pairing, release
to enter menu...
Remaining:      3 sec
```

4. Release the button within 3 seconds to access the Setup Mode.
5. When using setup menus, short press to scroll down to the next menu option and long press to select the item. You can use the Exit option in these menus to move up one menu level.

```
Optimizer pairing
Language <eng>
Communication
Maintenance
Information
Exit
```

6. Scroll down to the **Communication** sub-menu and select it. (Some of the menu items may vary depending on device and configuration).

```
Server<LAN>
LAN Conf
RS485-1 Conf<S>
RS485-2 Conf<S>
ZigBee Conf<S>
Wi-Fi Conf<N/A>
Cellular Conf
RS232 Conf
```

7. Scroll down and select the **ZigBee Conf** sub-menu. If **Zigbee Conf <N/A>** appears, and the ZigBee Conf sub-menu is not accessible, the ZigBee card is not installed correctly.

8. Select:

- **Device Type** → **HA** (Home Automation)
- **Protocol** → **HAM** (Home Automation)

```
Device Type <HA>
Protocol <HAM>
PAN ID
Scan Channel
Load ZB Defaults
```

9. Exit the Setup mode by selecting the Exit option in each sub-menu screen or wait for the device to automatically exit Setup mode. This concludes the card configuration using the LCD button. When the HA Device Type is selected, a Device Manager menu item will appear in the main configuration menu.

```
Country <Italy>
Language <Eng>
Communication
Power Control
Display
Maintenance
Information
```

▶ **To configure the ZigBee card in HD-wave inverters:**

Use the LCD buttons to toggle through the informative status screens, and for communication setup. These buttons are at the front, under the LCD screen.

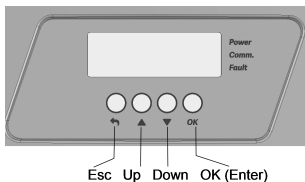

Figure 11: Inverter connector panel

1. Verify that the inverter ON/OFF switch is OFF.
2. Enter the inverter Setup mode:
 - SolarEdge 1Ph/3Ph inverters - Press the Enter button for 5-10 seconds and release. Enter the password 12312312.
 - SolarEdge HD-Wave inverter - Press the OK button for 5-10 seconds and release. Enter the password 12312312 (**Up=1, Down=2, OK=3**: Up → Down → OK → Up → Down → OK → Up → Down).
3. Scroll down to the Communication sub-menu and press Enter to select it. The Communication menu is displayed (Some of the menu items may vary depending on configuration).
4. Scroll down and select the **ZigBee Conf** sub-menu. If **ZigBee Conf <N/A>** appears, and the ZigBee Conf sub-menu is not accessible, the ZigBee card is not installed correctly.
5. Select:
 - **Device Type → HA** (Home Automation)
 - **Protocol → HAM** (Home Automation)

```
Device Type <HA>
Protocol <HAM>
PAN ID
Scan Channel
Load ZB Defaults
```

6. Exit the Setup mode by selecting the Exit option in each submenu screen or wait for the device to automatically exit Setup mode. This concludes the card configuration using the LCD button. When the HA Device Type is selected, a Device Manager menu item will appear in the main configuration menu

```
C o u n t r y   < I t a l y >
L a n g u a g e   < E n g >
C o m m u n i c a t i o n
P o w e r   C o n t r o l
D i s p l a y
M a i n t e n a n c e
I n f o r m a t i o n
```

► **To add devices to the ZigBee Network:**

Add Device Control products to the network as described in the Device Control installation guides. For further details, see:

- [Immersion Heater Controller Installation Guide](#)
- [Plug-In Socket with Metering Installation Guide](#)
- [AC Switch with Meter Installation Guide](#)
- [Dry-Contact Switch Installation Guide](#)

When selecting "Add devices" a rotating star and a message "Adding Devices" will appear.

If the message "ZigBee Card Not Ready. Try again." appears, this means that the card is still initializing and you should wait and then try to add devices again.

```
Z i g B e e   M o d u l e
N o t   R e a d y .
T r y   A g a i n
```

Appendix A: Technical Specifications

Functional		
Number of devices in a Device Control network	Up to 10	
Communications with monitoring portal	Single inverter installation - Ethernet / GSM ¹ ; Multiple inverter installation - RS485 and Ethernet / ZigBee / Wi-Fi / GSM ¹	
RF Performance		Unit
Transmit power	11.8	dBm
Receiver sensitivity	-102	dBm
Antenna gain	5	dBi
Operating frequency range	2.4-2.5	GHz
Outdoor (LOS) range	400 / 1300	m/ft
Indoor range ²	50 / 160	m/ft
Standard Compliance		
Safety	IEC60950, UL60950	
EMC approvals	ETSI (Europe), ACMA (Australia), Telec (Japan)	
Installation Specifications		
Antenna, mounting bracket and RF cable	Included	
Dimensions (H x W x D)	22.0 x 32.9 x 4.1 / 0.9 x 1.3 x 0.2	mm/in
Protection rating	IP65 (IP20 / indoor rated when installed inside Control and Communication Gateway)	

¹ Not to be used with SolarEdge data plan

² Approximate values, may differ depending on specific installation conditions

If you have technical queries concerning our products, please contact our support through SolarEdge service portal:
<http://www.solaredge.com/service/support>

Australia (+61)	1800 465 567
APAC (Asia Pacific) (+972)	073 240 3118
Benelux NL (+31)	0800-7105
BE (+32)	0800-76633
China (+86)	21 6212 5536
DACH and Rest of Europe (+49)	089 454 59730
France and Belgium (+33)	0800 917 410
Italy (+39)	0422 053700
Japan (+81)	03 6262 1223
Netherlands (+31)	0800 0221 089
New Zealand (+64)	0800 144 875
US & Canada (+1)	510 498 3200
United Kingdom (+44)	0800 028 1183
Greece (+49)	89 454 59730
Israel (+972)	073 240 3122
Middle East & Africa (+972)	073 240 3118
South Africa (+27)	0800 982 659
Turkey (+90)	216 706 1929
Worldwide (+972)	073 240 3118

Email to: support@solaredge.com

www.solaredge.com

solaredge



MAN-01-00267-1.2

If you have technical queries concerning our products, please contact our support through SolarEdge service portal:

<http://www.solaredge.com/service/support>

Australia (+61)	1800 465 567
APAC (Asia Pacific) (+972)	073 240 3118
Benelux NL (+31)	0800-7105
BE (+32)	0800-76633
China (+86)	21 6212 5536
DACH and Rest of Europe (+49)	089 454 59730
France and Belgium (+33)	0800 917 410
Italy (+39)	0422 053700
Japan (+81)	03 6262 1223
Netherlands (+31)	0800 0221 089
New Zealand (+64)	0800 144 875
US & Canada (+1)	510 498 3200
United Kingdom (+44)	0800 028 1183
Greece (+49)	89 454 59730
Israel (+972)	073 240 3122
Middle East & Africa (+972)	073 240 3118
South Africa (+27)	0800 982 659
Turkey (+90)	216 706 1929
Worldwide (+972)	073 240 3118
Email to: support@solaredge.com	

www.solaredge.com

solaredge



MAN-01-00267-1.2