



User manual

## PV Grid-Connected Inverter

Product Model: Sunny Deer Series(3K-5KTLM) Document Version 1.0(2014.07.20)

## Notice

This manual contains important safety instructions that must be followed during installation and maintenance of the equipment.

## Save these instructions!

This manual must be considered as an integral part of the equipment, and must be available at all times to everyone who interacts with the equipment. The manual must always accompany the equipment, even when it is transferred to another user or field.

## Copyright Declaration

The copyright of this manual belongs to Shenzhen SOFARSOLAR Co., Ltd. Any corporation or individual should not plagiarize, partially copy or fully copy it (including software, etc.), and no reproduction or distribution of it in any form or by any means. All rights reserved. SOLARSOFAR reserves the right of final interpretation. This manual is subject to change according to user's or customer's feedback. Please check our website at <http://www.sofarsolar.com> for latest version.

## Shenzhen SOFARSOLAR Co., Ltd.

ADD 3A, Huake Building, East Tech. Park, Qiaoxiang Road, Nanshan District, Shenzhen, China

[Http://www.sofarsolar.com](http://www.sofarsolar.com)

P. C. 518000

E-mail: [service@sofarsolar.com](mailto:service@sofarsolar.com)

# Preface

## Outline

Please read the product manual carefully before installation, operation or maintenance. This manual contains important safety instructions and installation instructions that must be followed during installation and maintenance of the equipment.

### • Scope

This product manual describes the installation, electrical connections, commissioning, maintenance and troubleshooting of Sunny Deer series inverters:

SOFAR 3000TLM SOFAR 3680TLM SOFAR 4000TLM SOFAR 4600TLM SOFAR 5000TLM





Keep this manual where it will be accessible at all times.

### • Target Group

This manual is intended for qualified electrical technical personnel who are responsible for inverter installation and commissioning in the PV power system and the PV plant operator.

### • Symbols Used

This manual provides safety operation information and uses the symbol in order to ensure personal and property security and use the inverter efficiently when operating the inverter. You must understand these emphasized information to avoid the personal injury and property loss. Please read the following symbols used in this manual carefully.

|   |   |
|---|---|
| <br><b>Danger</b>      | <b>Danger indicates a hazardous situation which, if not avoided, will result in death or serious injury.</b>      |
| <br><b>Warning</b>   | <b>Warning indicates a hazardous situation which, if not avoided, could result in death or serious injury.</b>    |
| <br><b>Caution</b>   | <b>Caution indicates a hazardous situation which, if not avoided, could result in minor or moderate injury.</b>   |
| <br><b>Attention</b> | <b>Attention indicated potential risks which, if not avoided, may lead to equipment fault or property damage.</b> |
| <br><b>Note</b>      | <b>Note provides tips that are valuable for the optimal operation of the product.</b>                             |

# Table of contents

|  |           |
|--|-----------|
| <b>Preface</b> .....                             | <b>II</b> |
| <b>1 Basic safety information</b> .....          | <b>1</b>  |
| 1.1 Safety instructions .....                    | 1         |
| 1.2 Symbols and signs .....                      | 3         |
| <b>2 Product characteristics</b> .....           | <b>5</b>  |
| 2.1 Product identification .....                 | 5         |
| 2.2 Function description .....                   | 7         |
| 2.3 Efficiency curve .....                       | 8         |
| <b>3 Installation</b> .....                      | <b>9</b>  |
| 3.1 Installation Process .....                   | 9         |
| 3.2 Checking Before Installation .....           | 9         |
| 3.3 Tools .....                                  | 11        |
| 3.4 Determining the Installation Position .....  | 12        |
| 3.5 Moving the Sunny Deer series inverter .....  | 14        |
| 3.6 Installing Sunny Deer series inverter .....  | 15        |
| <b>4 Electrical Connections</b> .....            | <b>16</b> |
| 4.1 Electrical connection .....                  | 16        |
| 4.2 Connecting PGND Cables .....                 | 17        |
| 4.3 Connecting DC Input Power Cables .....       | 18        |
| 4.4 Connecting AC Output Power Cables .....      | 20        |
| 4.5 Connecting Communications Cables .....       | 23        |
| 4.6 Communication method .....                   | 26        |
| <b>5 Commissioning of inverter</b> .....         | <b>29</b> |
| 5.1 Safety inspection before commissioning ..... | 29        |
| 5.2 Start inverter .....                         | 29        |

|   |           |
|---|-----------|
| <b>6 Operation interface</b> .....                                | <b>30</b> |
| 6.1 Operation and Display Panel .....                             | 30        |
| 6.2 Standard Interface .....                                      | 31        |
| 6.3 Main Interface .....  | 33        |
| 6.4 Update Software online .....                                  | 42        |
| <b>7 Trouble shooting and maintenance</b> .....                   | <b>43</b> |
| 7.1 Trouble shooting .....  | 43        |
| 7.2 Maintenance .....   | 47        |
| <b>8 Technical data</b> .....                                     | <b>48</b> |
| 8.1 Input parameter (DC) .....                                    | 48        |
| 8.2 Output parameter (AC) .....                                   | 48        |
| 8.3 Efficiency, Safety and Protection .....                       | 49        |
| 8.4 General Data .....  | 49        |
| <b>9 Sofar SolarMAN Quick_Setup Manual (Wi-Fi Optional)</b> ..... | <b>50</b> |
| 9.1 Network setting .....   | 50        |
| 9.2 Register on SolarMAN Portal .....                             | 58        |
| 9.3 Log in SolarMAN Portal to manage power station .....          | 60        |
| <b>10 Quality Assurance</b> .....                                 | <b>62</b> |

# Basic safety information

|  |   |
|--|---|
| <br><b>Note</b> | <p>If you have any question or problem when reading the following information, please contact Shenzhen SOFARSOLAR Co., Ltd.</p> |
|--|---|

## Outlines of this chapter

### Safety instruction

It mainly introduce the safety instruction when install and operate the equipment.

### Symbols and signs

It mainly introduce the safety symbols on the inverter.

## 1.1 Safety instructions

- Read and understand the instructions of this manual, and be familiar with relevant safety symbols in this chapter, then start to install and troubleshoot the equipment.
- According to the national and state requirements, before connecting to the electrical grid, you must get permission from the local electrical grid operator, and the operation can only be performed by qualified electrical engineer.
- Please contact the nearest authorized service center if any maintenance or repair is needed. Contact your distributor for the information of the nearest authorized service center. Do NOT repair it by yourself, it may cause injury or property damage.
- Before installing and maintaining the equipment, you should turn the DC switch OFF to cut off the high voltage DC of the PV array. You can also turn the switch in the PV combiner box OFF to cut off the high voltage DC. Otherwise, serious injury may be caused.

## Qualified persons

Make sure the operator has the necessary skill and training to do his/her job. Staff in charge of using and maintaining the equipment must be skilled, aware and mature for the described tasks and must have the reliability to correctly interpret what is described in the manual. For Safety reasons only a qualified electrician, who has received training and / or has demonstrated skills and knowledge in construction and in operation of this device, can install this inverter. Shenzhen SOFARSOLAR Co., Ltd. does not take any responsibility for the property destruction and personal injury caused by any incorrect use.

## Installation requirements

Please install inverter according to the following section. Fix the inverter on an appropriate objects with enough load bearing capacity (such as walls, PV racks etc.), and ensure that inverter is vertical placed. Choose a place suitable for installing electrical devices. And assure there is enough fire exit space, convenient for maintenance. Maintain proper ventilation to ensure enough air cycle to cool the inverter.







## Transport requirements



If you find packing problems that may cause the damage of the inverter, or find any visible damage, please immediately notice the responsible transportation company. You can ask your solar system installer or Shenzhen SOFARSOLAR Co., Ltd. for help if necessary. Transport of the equipment, especially by road, must be carried out with suitable means for protecting the components (in particular, the electronic components) from violent shocks, humidity, vibration, etc.

## Electric connection



Please comply with all the current electrical regulations about accident prevention in dealing with the solar inverter.

|   |  |
|---|--|
| <br><b>Danger</b>    | <p>Before the electrical connection, make sure to use opaque material to cover the PV modules or to disconnect PV array DC switch. Exposure to the sun, PV array will produce a dangerous voltage!</p>                               |
| <br><b>Warning</b>   | <p>All installation accomplished only by professional electrical engineer!</p> <ul style="list-style-type: none"> <li>• must be trained;</li> <li>• Completely read the manual operation and understand relevant matters.</li> </ul> |
| <br><b>Attention</b> | <p>Get permission from the local electrical grid operator, complete all electrical connections by professional electrical engineer, then connect inverter to electrical grid.</p>  |
| <br><b>Note</b>      | <p>It's forbidden to remove the tamper evident label, or open the inverter. Otherwise Sofarsolar will not provide warranty or maintenance!</p>   |

## Operation

|   |   |
|---|---|
|  | <p><b>Touching the electrical grid or the terminal of the equipment may lead to electrocution or fire!</b></p> <ul style="list-style-type: none"> <li>• Don't touch the terminal or conductor connected to the electrical grid.</li> <li>• Pay attention to any instructions or safety documents related to grid connection.</li> </ul> |
| <b>Danger</b>   |   |
|  | <p>Some internal components will be very hot when inverter is working. Please wear protective gloves!</p>   |
| <b>Attention</b>  |   |

## Maintenance and repair

|   |   |
|---|---|
|  | <ul style="list-style-type: none"> <li>• Before any repair work, turn OFF the AC circuit breaker between the inverter and electrical grid first, then turn OFF the DC switch.</li> <li>• After turning OFF the AC circuit breaker and DC switch, wait for 5 minutes at least before carrying out any maintenance or repair work.</li> </ul>   |
| <b>Danger</b>   |   |
|  | <ul style="list-style-type: none"> <li>• Inverter should work again after removing any faults. If you need any repair work, please contact with the local authorized service center;</li> <li>• Do NOT disassemble the inverter without authorization. It will void the warranty and Shenzhen SOFARSOLAR Co., Ltd. will not take any responsibility for the losses caused by that.</li> </ul> |
| <b>Attention</b>  |   |

## EMC / noise level of inverter

Electromagnetic compatibility (EMC) refers to that one electrical equipment functions in a given electromagnetic environment without any trouble or error, and impose no unacceptable effect upon the environment. Therefore, EMC represents the quality characters of an electrical equipment.



- The inherent noise-immune character: immunity to internal electrical noise.
- External noise immunity: immunity to electromagnetic noise of external system.
- Noise emission level: influence of electromagnetic emission upon environment.

|   |   |
|---|---|
|  | <p><b>Electromagnetic radiation from inverter may be harmful to health!</b></p> <ul style="list-style-type: none"> <li>• Please do not continue to stay around the inverter in less than 20 cm when inverter is working.</li> </ul> |
| <b>Danger</b>   |   |

## 1.2 Symbols and signs









### Safety symbols

|   |   |
|---|---|
|  | <p><b>Caution of burn injuries due to hot enclosure!</b></p> <ul style="list-style-type: none"> <li>• You can only touch the screen and pressing key of the inverter while it's working.</li> </ul> |
| <b>Caution</b>  |   |

|   |   |
|---|---|
|  | <p><b>PV array should be grounded in accordance to the requirements of the local electrical grid operator!</b></p> <ul style="list-style-type: none"> <li>• We suggest that all PV module frames and inverter are reliably grounded to protect the PV system and personnel security.</li> </ul> |
| <b>Attention</b>  |   |
|  | <p>Ensure input DC voltage &lt; Max. DC voltage. Over voltage may cause permanent damage to inverter or other losses, which will not be included in warranty!</p>   |
| <b>Warning</b>  |   |

## Signs on the inverter

There are some symbols which are related to security on the inverter. Please read and understand the content of the symbols, and then start the installation.

|   |   |
|---|---|
|    | <p>There is a residual voltage in the inverter! Before opening the equipment, operator should wait for five minutes to ensure the capacitor is discharged completely.</p> |
|    | <p>Be careful of high voltage.</p>  |
|    | <p>Be careful of high temperature.</p>  |
|    | <p>Comply with the Conformance Européenne (CE) certification.</p>   |
|  | <p>Grounding point.</p>   |
|  | <p>Please read this manual before install Sunny Deer series.</p>  |
|  | <p>This indicates the degree of protection of the equipment according to IEC standard 70-1 (EN 60529 June 1997).</p>  |
|  | <p>Positive pole and negative pole of the input voltage (DC).</p>   |

# 2 Product characteristics

## Outlines of this chapter

### Product dimensions

It introduces the field of use, and the overall dimensions of Sunny Deer series inverters.

### Function description

It introduces how Sunny Deer series inverters work and the function modules inside.

### Efficiency curves

It introduces the efficiency curves of in the inverter.

## 2.1 Product dimensions

### Field of use

Sunny Deer series is a Dual MPPT grid-tied PV inverter which converts the DC power generated by PV arrays into sine wave single-phase AC power and feeds it to the public electrical grid, AC circuit breaker (refer to Section 4.4) and DC switch used as disconnect device, and the disconnect device shall be easily accessible.

Figure2-1 PV Grid-tied System



Sunny Deer series inverters can only be used with photovoltaic modules that do not require one of the poles to be grounded. The operating current during normal operation must not exceed the limits specified in the technical specifications. Only the photovoltaic modules can be connected to the input of the inverter (do not connect batteries or other sources of power supply).

- The choice of optional parts of inverter should be made by a qualified technician who knows the installation conditions clearly.
- Overall dimensions: L×W×H=478mm×344mm×170mm.

Figure2-2 Front view and left view dimensions

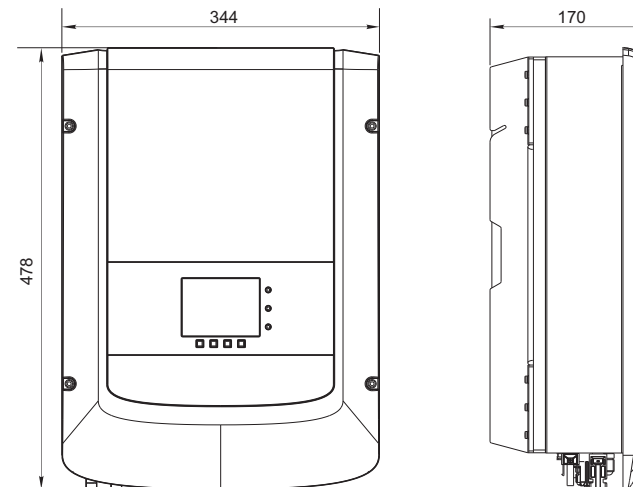
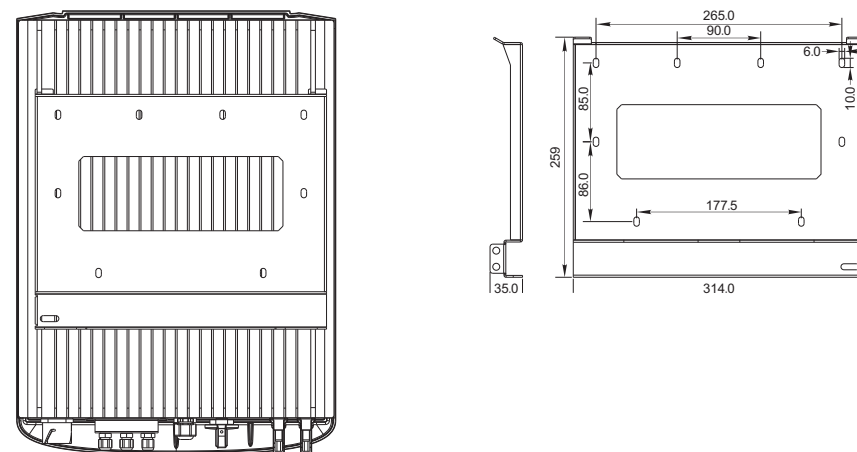

Figure2-3 Back view and Bracket dimensions









# 3 Installation

## Outlines of this chapter

This topic describes how to install the Sunny Deer series inverter.

### Installation notes

|   |  |
|---|--|
| <br><b>Danger</b>    | <ul style="list-style-type: none"> <li>Do NOT install the Sunny Deer series on a flammable material.</li> <li>Do NOT install the Sunny Deer series in an area used to store flammable or explosive materials.</li> </ul>   |
| <br><b>Caution</b>   | The enclosure and heat sink are very hot while the inverter is working, therefore do NOT install the Sunny Deer series in places where you might touch them inadvertently.   |
| <br><b>Attention</b> | <ul style="list-style-type: none"> <li>Consider the weight of Sunny Deer series when transporting and moving the Sunny Deer Series inverters.</li> <li>Choose an appropriate mounting position and surface.</li> <li>Assign at least two persons to install the Sunny Deer series inverter.</li> </ul> |

## 3.1 Installation Process

Figure3-1 Installation flowchart

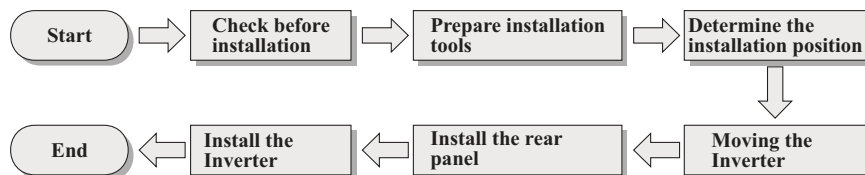

## 3.2 Checking Before Installation











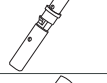

### Checking Outer Packing Materials

Packing materials and components may be damaged during transportation. Therefore, check the outer packing materials before installing the inverter. Check the outer packing materials for damage, such as holes and cracks. If any damage is found, do not unpack the Sunny Deer series and contact the dealer as soon as possible. You are advised to remove the packing materials within 24 hours before installing the Sunny Deer series inverter.

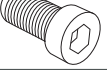

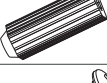
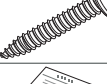



### Checking Deliverables

After unpacking the inverter, check whether deliverables are intact and complete. If any damage is found or any component is missing, contact the dealer.

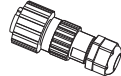
Table3-1 shows the components and mechanical parts that should be delivered



| No. | Pictures  | Description                                       | Quantity           |
|-----|---|---|--------------------|
| 1   |    | Sunny Deer Series                                 | 1 pcs              |
| 2   |    | Rear panel  | 1 pcs              |
| 3   |    | PV+ input terminal                                | 2 pcs              |
| 4   |    | PV-input terminal                                 | 2 pcs              |
| 5   |    | Metal terminals secured to PV+ input power cables | 2 pcs              |
| 6   |    | Metal terminals secured to PV- input power cables | 2 pcs              |
| 7   |    | M5 Hexagon screws                                 | 2 pcs              |
| 8   |    | M6 flat washer                                    | 10 pcs             |
| 9   |   | Expansion bolts                                   | 10 pcs(spare 2pcs) |
| 10  |  | Self-tapping screw                                | 8 pcs              |
| 11  |  | Manual  | 1 pcs              |
| 12  |  | The warranty card                                 | 1 pcs              |
| 13  |  | Certificate                                       | 1 pcs              |





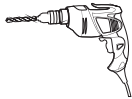
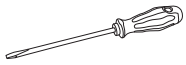
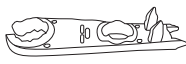
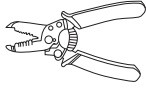

| No. | Pictures  | Description               | Quantity |
|-----|---|---------------------------|----------|
| 14  |  | AC output terminal        | 1PCS     |
| 15  |  | 485 terminal (2pin)       | 1PCS     |
| 16  |  | Dry relay terminal (3pin) | 1PCS     |
| 17  |  | I/O terminal (6pin)       | 1PCS     |
| 18  |  | Stopper A                 | 1PCS     |
| 19  |  | Stopper B                 | 1PCS     |

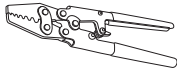
### 3.3 Tools

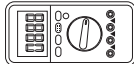
Prepare tools required for installation and electrical connections. Table 3-2 shows the tools required for installation and electrical connections.

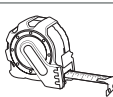
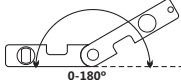
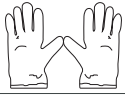
| No. | Tool  | Model                                    | Function   |
|-----|---|--|--|
| 1   |    | Hammer drill<br>Recommend drill dia. 6mm | Used to drill holes on the wall                    |
| 2   |   | Screwdriver                              | wiring   |
| 3   |  | Removal tool                             | Remove PV terminal                                 |
| 4   |  | Wire stripper                            | Strip wire   |
| 5   |  | 4mm Allen Wrench                         | Turn the screw to connect rear panel with inverter |
| 6   |  | Crimping tools                           | Used to crimp power cables                         |

| No. | Tool  | Model                | Function   |
|-----|---|----------------------|--|
| 7   |  | Multi-meter          | Used to check grounding                                  |
| 8   |  | Marker               | Used to mark signs                                       |
| 9   |  | Measuring tape       | Used to measure distances                                |
| 10  |  | Level                | Used to ensure that the rear panel is properly installed |
| 11  |  | ESD gloves           | Operators wear   |
| 12  |  | Safety goggles       | Operators wear   |
| 13  |  | Anti-dust respirator | Operators wear   |

### 3.4 Determining the Installation Position

Determine an appropriate position for installing the Sunny Deer series inverter. Comply with the following requirements when determining the installation position:

Figure3-2 Installation Requirements

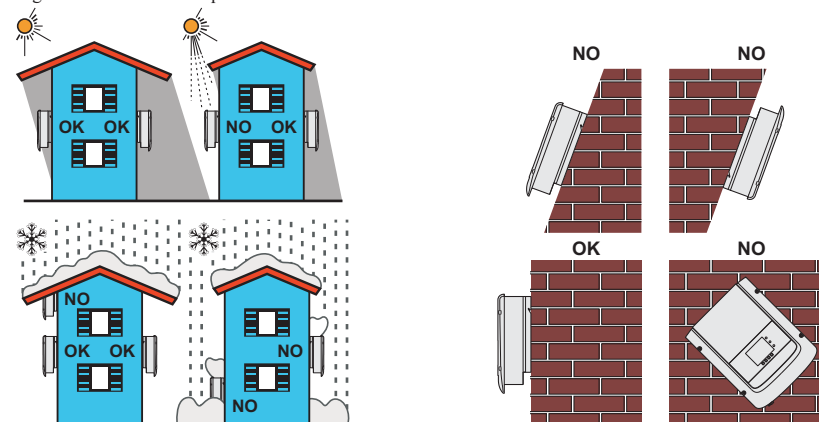

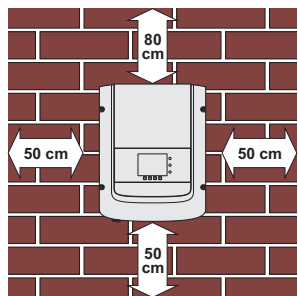
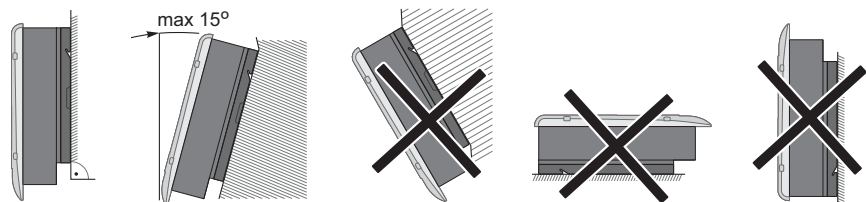

clearance for single Sunny Deer series inverter

Installation of multiple Sunny Deer Series inverters

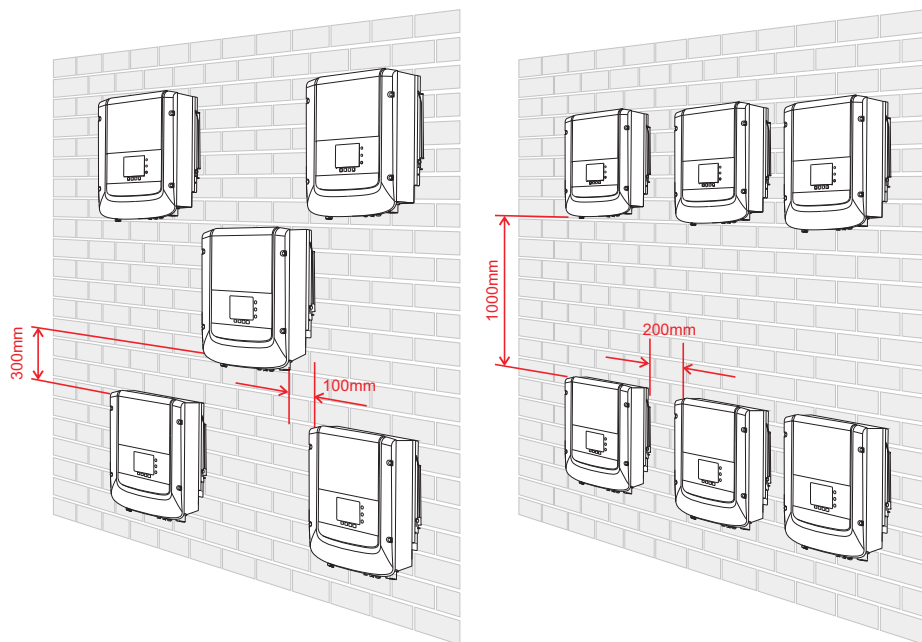

### 3.5 Moving the Sunny Deer series inverter

This topic describes how to move the Sunny Deer series to the installation position horizontally

**Step 1** Open the packaging, insert hands into the slots on both sides of the Sunny Deer series and hold the handles, as shown in Figure 3-3 and Figure 3-4.

Figure 3-3 Moving the Sunny Deer series (1)

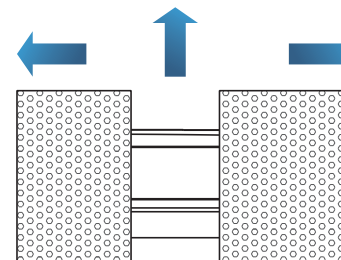
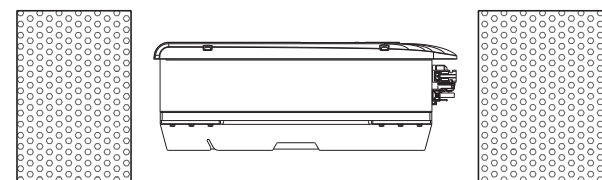

Figure 3-4 Moving the Sunny Deer series (2)



**Step 2** Lift the Sunny Deer series from the packing case and move it to the installation position.

|           |   |
|-----------|---|
|           | <ul style="list-style-type: none"> <li>To prevent device damage and personal injury, keep balance when moving the Sunny Deer series because the Sunny Deer series is heavy.</li> <li>Do not put the Sunny Deer series with its wiring terminals contacting the floor because the power ports and signal ports are not designed to support the weight of the Sunny Deer series. Place the Sunny Deer series horizontally.</li> <li>When placing the Sunny Deer series on the floor, put foam or paper under the Sunny Deer series to protect its shell.</li> </ul> |
| Attention |   |

--- End

### 3.6 Installing Sunny Deer series inverter

**Step 1** Determine the positions for drilling holes, ensure the hole positions are level, then mark the hole positions using a marker pen, use the hammer drill to drill holes on the wall. Keep the hammer drill perpendicular to the wall, do not shake when drilling, so as not to damage the wall. If the error of the hole positions is too big, you need to reposition.

**Step 2** Insert the expansion bolt vertically into the hole, pay attention to the insertion depth of the expanding bolt (should be deep enough).

**Step 3** Align the rear panel with hole positions, fix the rear panel on the wall by tightening the expansion bolt with the nuts.

Figure 3-5

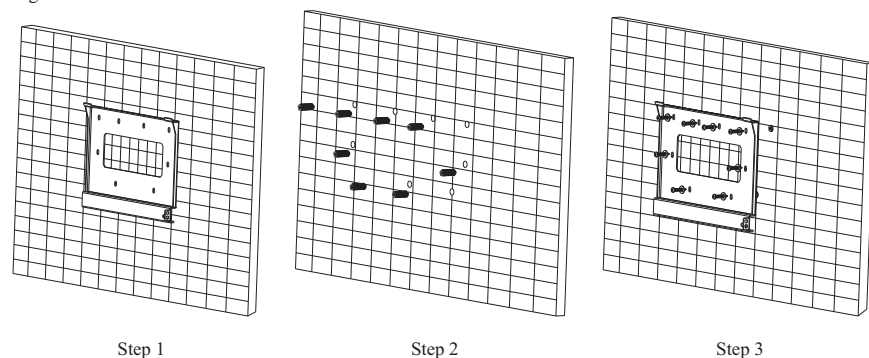

**Step 4** Hook the inverter to the rear panel. Using an M5 screw to secure the inverter to the rear panel to ensure safety.

**Step 5** You can secure the Sunny Deer series inverter to the rear panel and protect it from stealing by installing an anti-theft lock (this action is optional).

Figure 3-6

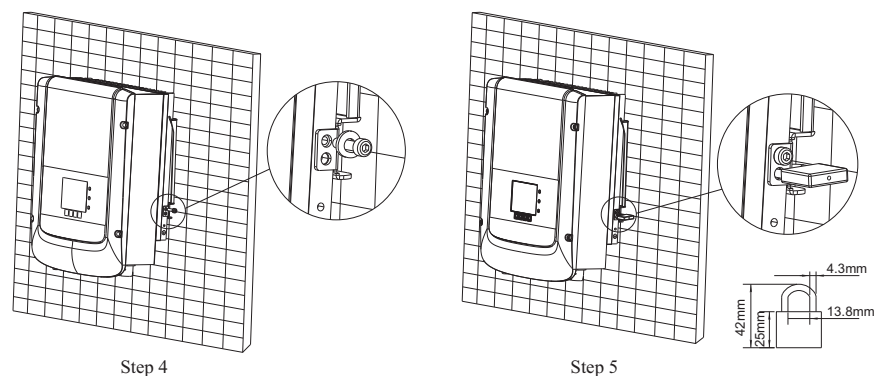

--- End

# 4 Electrical Connections

## Outlines of this chapter

This topic describes the Sunny Deer series inverter electrical connections. Read this part carefully before connecting cables.

### NOTE:

Before performing electrical connections, ensure that the DC switch is OFF. Since the stored electrical charge remains in a capacitor after the DC switch is turned OFF. So it's necessary to wait for at least 5 minutes for the capacitor to be electrically discharged.

|                  |   |
|------------------|---|
|                  | <b>Installation and maintenance of inverter, must be operated by professional electrical engineer.</b>  |
| <b>Attention</b> |   |
|                  | <b>PV modules generate electric energy when exposed to sunlight and can create an electrical shock hazard. Therefore, before connecting DC input power cable, cover PV modules using opaque cloth.</b>  |
| <b>Danger</b>    |   |
|                  | <ul style="list-style-type: none"> <li>The PV array maximum voltage must be <math>\leq 600V</math>, max output of single inverter is 4.6KVA and max output of PV system is 13.8KVA in Germany.</li> <li>Sunny Deer Series has 2 MPP trackers, all PV modules connected to the same MPPT should have similar rated electrical characteristics (including <math>I_{sc}</math>, <math>V_{oc}</math>, <math>I_m</math>, <math>V_m</math>, <math>P_m</math> and temperature coefficients), have the same number of series connected PV modules and be all in the same orientation (azimuth and tilt angle).</li> </ul> |
| <b>Note</b>      |   |

## 4.1 Electrical connection

Figure4-1 Shows the flowchart for connecting cables to the Sunny Deer series

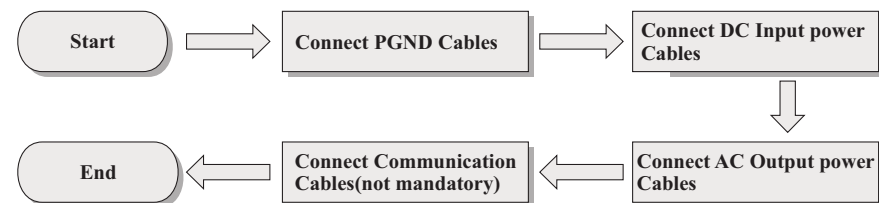

## 4.2 Connecting PGND Cables

Connect the Sunny Deer series to the grounding electrode using protection ground (PGND) cables for grounding purposes.



### Attention

The inverter is transformer-less, requires the positive pole and negative pole of the PV array are NOT grounded. Otherwise it will cause inverter failure. In the PV power system, all non current carrying metal parts (such as: PV module frame, PV rack, combiner box enclosure, inverter enclosure) should be connected to earth.

### Prerequisites:

The PGND cables are prepared ( $\geq 5\text{mm}^2$  outdoor power cables are recommended for grounding purposes), the color of cable should be yellow-green.

### Procedure:

**Step 1** Remove the insulation layer with an appropriate length using a wire stripper, as shown in Figure 4-2.

Figure4-2 Preparing a ground cable (1)

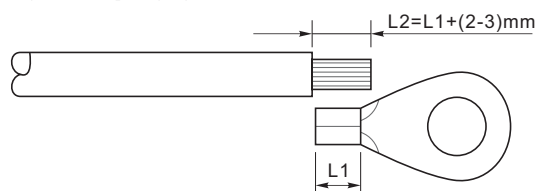

**Note** L2 is 2 to 3mm longer than L1

**Step 2** Insert the exposed core wires into the OT terminal and crimp them by using a crimping tool, as shown in Figure 4-3.

Figure4-3 Preparing a ground cable (2)

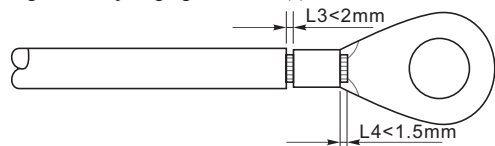

**Note 1:** L3 is the length between the insulation layer of the ground cable and the crimped part. L4 is the distance between the crimped part and core wires protruding from the crimped part.

**Note 2:** The cavity formed after crimping the conductor crimp strip shall wrap the core wires completely. The core wires shall contact the terminal closely.

**Step 3** Install the crimped OT terminal, flat washer using M5 screw, and tighten the screw to a torque of 3 N.m using an Allen wrench.

Figure4-4 Ground terminal composition

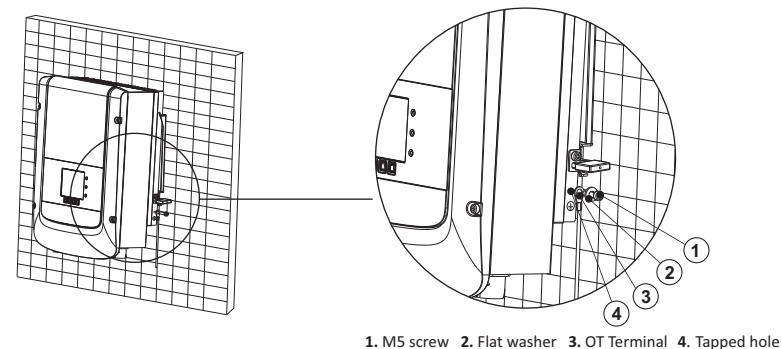

## 4.3 Connecting DC Input Power Cables

Table 4-1 Recommended DC input cable specifications

| Cross-Sectional Area (mm <sup>2</sup> ) |                   | External Cable Diameter(mm) |
|---|-------------------|-----------------------------|
| Range                                   | Recommended Value |                             |
| 4.0~6.0                                 | 4.0               | 4.5~7.8                     |

### Procedure

**Step 1** Remove cable glands from the positive and negative connectors.

**Step 2** Remove the insulation layer with an appropriate length from the positive and negative power cables by using a wire stripper as show in Figure 4-5.

Figure 4-5 Connecting DC input power cables

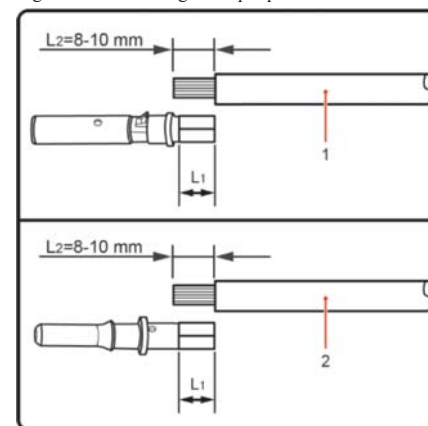

1. Positive power cable 2. Negative power cable



### Note

L2 is 2 to 3 mm longer than L1.

**Step 3** Insert the positive and negative power cables into corresponding cable glands.

**Step 4** Insert the stripped positive and negative power cables into the positive and negative metal terminals respectively and crimp them using a crimping tool. Ensure that the cables are crimped until they cannot be pulled out by force less than 400 N, as shown in Figure 4-6.

Figure 4-6 Connecting DC input power cables

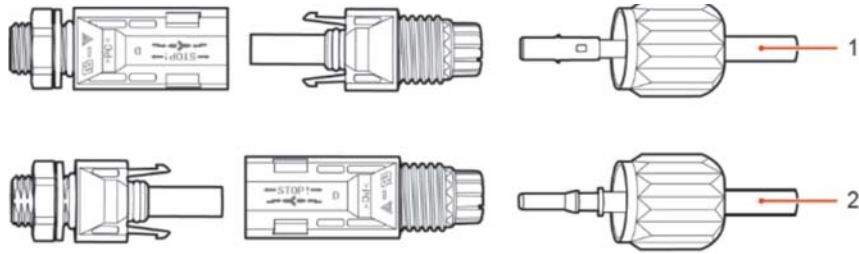

1. Positive power cable 2. Negative power cable

**Step 5** Insert crimped power cables into corresponding housings until you hear a "click" sound. The power cables snap into place.

**Step 6** Reinstall cable glands on positive and negative connectors and rotate them against the insulation covers.

**Step 7** Insert the positive and negative connectors into corresponding DC input terminals of the Sunny Deer Series until you hear a "click" sound, as shown in Figure 4-7.

Figure 4-7 Connecting DC input power cables

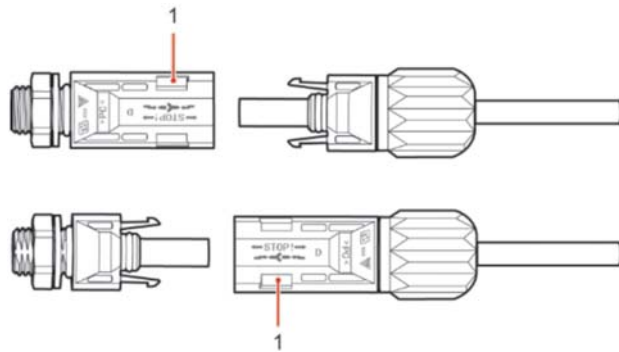

1. Bayonet



**Note:**  
Insert the stoppers into the unused DC connectors.

--- End

### Follow-up Procedure

To remove the positive and negative connectors from the Sunny Deer Series, insert a removal wrench into the bayonet and press the wrench with an appropriate strength, as shown in Figure 4-8.

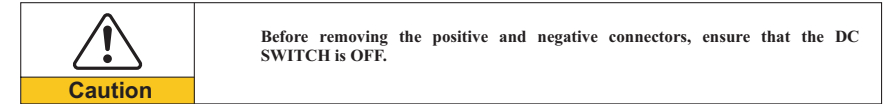
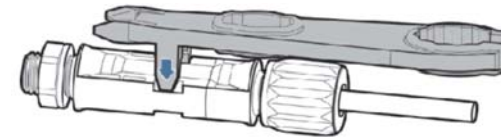
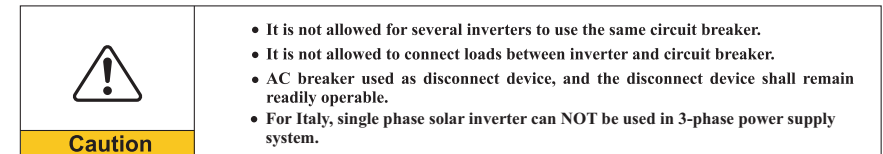

Figure 4-8 Removing a DC input connector



## 4.4 Connecting AC Output Power Cables

Connect the Sunny Deer Series to the AC power distribution frame (PDF) or power grid using AC output power cables.



### Context

All the AC output cables used for the inverters are outdoor three-core cables. To facilitate the installation, use flexible cables. Table 4-2 lists the recommended specifications for the cables.

Figure 4-9 NOT allowed: connect loads between inverter and circuit breaker

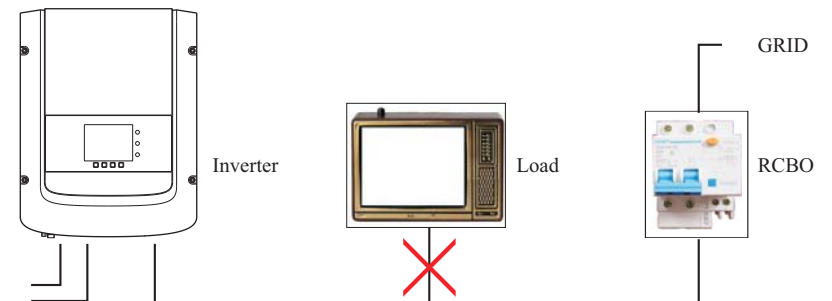
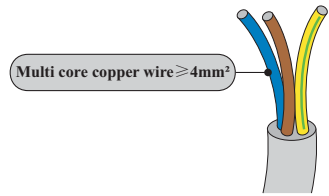

Table4-2 Recommended AC output cable specifications

| Model           | Sofar 3000TLM      | Sofar 3680TLM      | Sofar 4000TLM      | Sofar 4600TLM      | Sofar 5000TLM      |
|-----------------|--------------------|--------------------|--------------------|--------------------|--------------------|
| Cable(Copper)   | ≥ 4mm <sup>2</sup> | ≥ 4mm <sup>2</sup> | ≥ 4mm <sup>2</sup> | ≥ 5mm <sup>2</sup> | ≥ 5mm <sup>2</sup> |
| Circuit Breaker | 20A/230V/2P/0.1A   | 25A/230V/2P/0.1A   | 25A/230V/2P/0.1A   | 32A/230V/2P/0.1A   | 32A/230V/2P/0.1A   |

**Multi core copper wire**



AC cable should be correctly sized to ensure the power loss in AC cable is less than 1% of the rated power. If the resistance of the AC cable is too high, it will cause a huge increase in the AC voltage, which may lead to a disconnection of the inverter from the electrical grid. The relationship between power loss in AC cable and wire length, wire cross sectional area is shown in the following figure:

Figure 4-10 wire length, wire cross sectional area and wire power loss

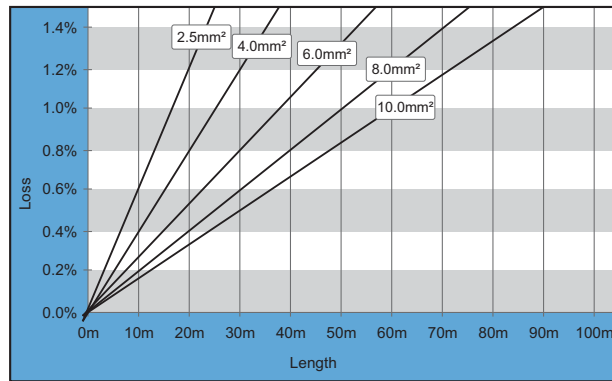

SOFAR inverter is equipped with IP66 AC output connector dedicated for PV inverter, customer need to make AC output cable connections by himself, and the appearance of the AC connector is shown below:

Figure 4-11 AC output connector

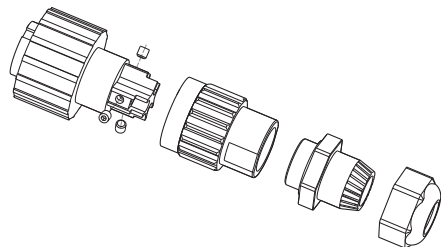

**AC wire connections procedure:**

**Step 1** Select appropriate cables according to Table 4-2, Remove the insulation layer of the AC output cable using a wire stripper according to the figure shown below: A: 30~50mm B: 6~8mm;

Figure 4-12

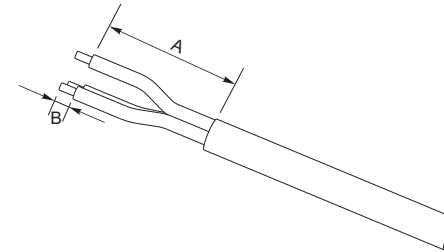

**Step 2** Disassemble the AC connector according to the figure shown below: insert the AC output cable (with its insulation layer stripped according to step 1) through the waterproof locking cable gland;

Figure 4-13

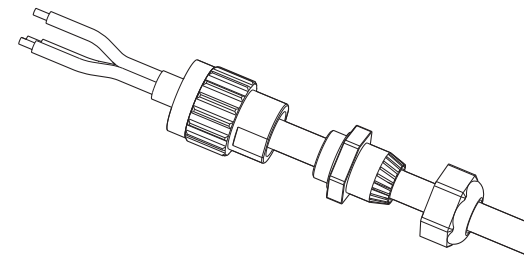

**Step 3** Connect AC output cable as per the following requirements:

- Connect the yellow-green wire to the hole labeled 'PE', fasten the wire using an Allen wrench;
- Connect the brown wire to the hole labeled 'L', fasten the wire using an Allen wrench;
- Connect the blue wire to the hole labeled 'N', fasten the wire using an Allen wrench;

Figure 4-14

L--brown, N--blue, PE--yellow/green

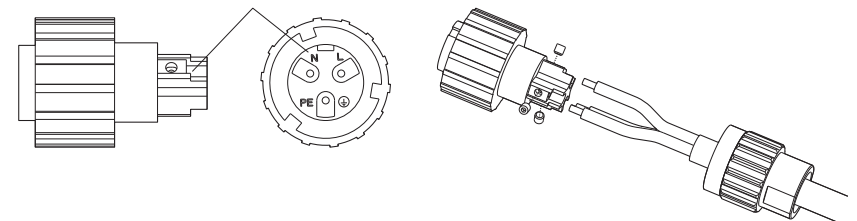



**Step 4** Secure the locking cable gland clockwise, shown as below: make sure that all the wires are securely connected;

**Step 5** Connect the AC output connector to the output wiring terminal of SOFAR inverter, rotate the AC connector clockwise until the fastener reaches its designated position, as shown below:

Figure 4-15

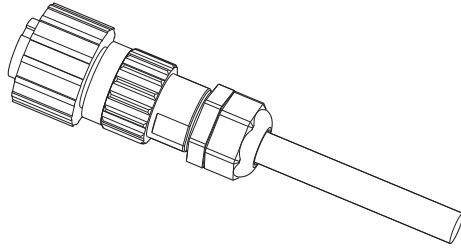

Step 4

Figure 4-16

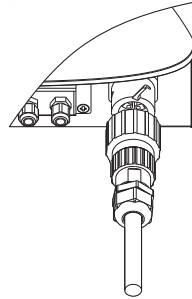

Step 5

## 4.5 Connecting Communications Cables

The wiring methods are the same for RS485, dry contact and I/O, this part describes their wiring methods all together:

Table4-3 Recommended communication cable sizes are shown below

| Communication function | RS485                  | Dry contact            | I/O                    |
|------------------------|------------------------|------------------------|------------------------|
| Cable size             | 0.5~1.5mm <sup>2</sup> | 0.5~1.5mm <sup>2</sup> | 0.5~1.5mm <sup>2</sup> |
| Outside diameter       | 2.5~6mm                | 2.5~6mm                | 2.5~6mm                |

**Step 1** Remove the communication waterproof cover using a screwdriver;

Figure 4-17

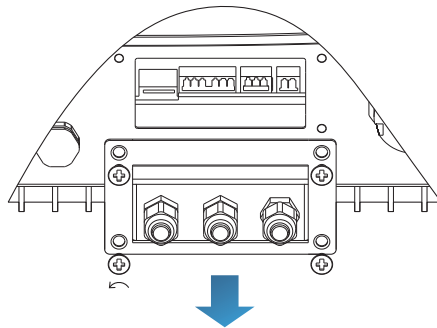

**Step 2** Unlock the waterproof cable gland, remove the stopper in the waterproof connector;

Figure 4-18

A1 Waterproof stopper

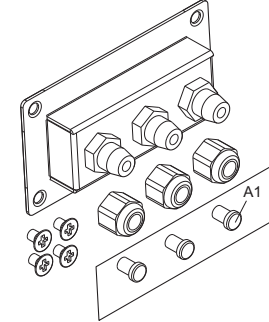

**Note:**

The waterproof connectors correspond to: I/O, dry contact, RS485 from left to right. Unlock the waterproof connectors according to the communication functions you are using. Do NOT unlock the unused connectors.

**Step 3** Select appropriate cable according to Table 4-2, remove the insulation layer using a wire stripper, the length of the wire core is about 6mm, insert the cable through the cable gland and waterproof cover, as shown in the figure below:

Figure 4-19

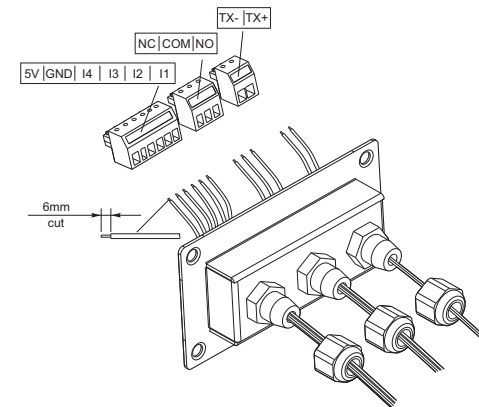

**Step 4** Choose the terminal according to Table 4-4, connect the wires as per the labels, and secure the wires using a slotted screwdriver.



**Note:**

keep the unused terminals for future use.



Table4-4 functional description of the communication terminals

| Type      | I/O    |        |         |         |         |         | Dry contact     |               |               | RS485                      |                            |
|-----------|--------|--------|---------|---------|---------|---------|-----------------|---------------|---------------|----------------------------|----------------------------|
| connector |        |        |         |         |         |         |                 |               |               |                            |                            |
| label     | 5V     | GND    | I4      | I3      | I2      | I1      | NC              | COM           | NO            | TX-                        | TX+                        |
| function  | source | ground | Input 4 | Input 3 | Input 2 | Input 1 | Normally closed | Common ground | Normally open | RS485 differential signal- | RS485 differential signal+ |

Figure 4-20

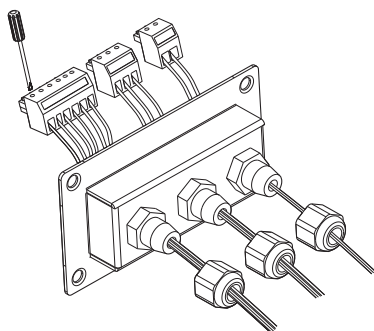

**Step 5** Insert the terminal as per the printed label, and then tighten the screws to fix the waterproof cover, rotate the cable gland clockwise to fasten it securely.

Figure 4-21

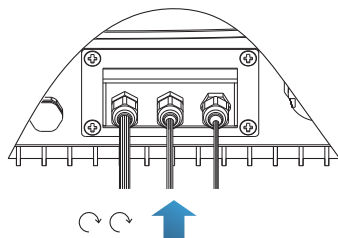

\* If users need to connect multiple inverters via RS485 wires, refer to the figure shown below: Rs485 wires are connected in parallel, so 4 wires may be required. First connect the two 485+ (TX+) wires in parallel, then connect the two 485-(TX-) wires in parallel, then insert them into the terminal and tighten the screws using a slotted screwdriver.



**Note:**

We recommend using two different colors of wires to connect TX-(485-) and TX+ (485+). Wires of the same color are connected together to avoid wrong wire connections.

Figure 4-22

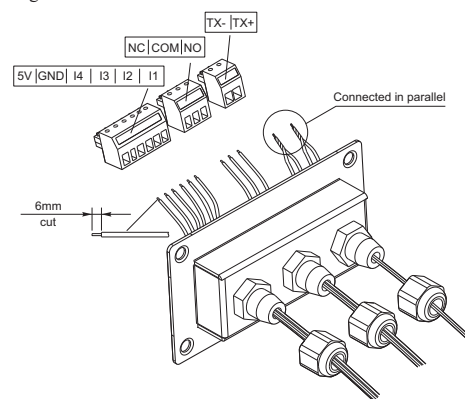

## 4.6 Communication method

Sunny Deer Series grid-connected inverters offer RS485 (standard) and Wi-Fi (optional) communication modes:

### A. Communication between one inverter and one PC:

#### 1. RS485

Refer to the figure shown below, connect the TX+ and TX- of the inverter to the TX+ and TX- of the RS485→ USB adapter, and connect the USB port of the adapter to the computer.(NOTE1)

Figure 4-23

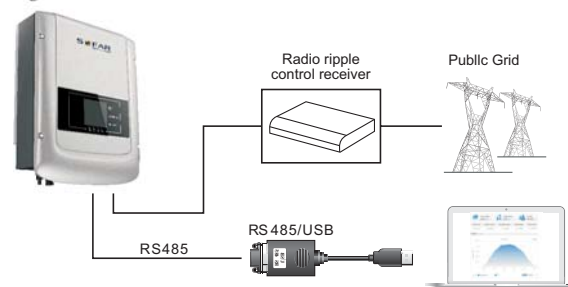

#### 2. WI-FI

Refer to the figure shown below: (wireless function required for the PC).(NOTE4)

Figure 4-24



The operation information (generated energy, alert, operation status) of the inverter can be transferred to PC or uploaded to the server (e.g. via S-WE01S) via Wi-Fi. You can register on the website: ( refer to Chapter 9 )

[http://www.solarmanpv.com/portal/Register/Regi\\_Pub.aspx](http://www.solarmanpv.com/portal/Register/Regi_Pub.aspx)

Using the Wi-Fi S/N number(NOTE3), then you can login the website:

<http://www.solarmanpv.com/portal/LoginPage.aspx> to remote monitors the inverter.

## B. Communication between multiple inverters and one PC:

### 1. RS485

Refer to the following figure: RS485 wires are connected in parallel between inverters, refer to section 4.5 of this manual for wire connection methods. Connect the TX+ and TX- of the inverter to the TX+ and TX- of the RS485→USB adapter; connect the USB port of the adapter to the computer. A maximum of 31 inverters can be connected in one daisy chain.(NOTE2)

Figure 4-25

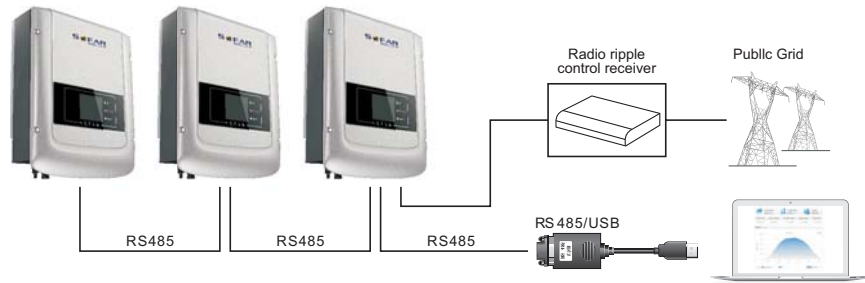

### 2. WI-FI

Refer to the figure shown below: (wireless function required for the PC).(NOTE4)

Figure 4-26



The operation information (generated energy, alert, operation status) of the inverter can be transferred to PC or uploaded to the server (e.g. via S-WE01S) via Wi-Fi. You can register on the website:( refer to section 9 )

[http://www.solarmanpv.com/portal/Register/Regi\\_Pub.aspx](http://www.solarmanpv.com/portal/Register/Regi_Pub.aspx)

Using the Wi-Fi S/N number(NOTE3), then you can login the website:

<http://www.solarmanpv.com/portal/LoginPage.aspx> to remote monitors the inverter.



**Note1:**

The length of the RS485 communication cable should be less than 1000 m.



**Note2:**

When multiple inverters are connected via RS485 wires, set mod-bus address to differentiate the inverters. Refer to section 6.3 for RS485 address setting, max output of single inverter is 4.6KVA and max output of PV system is 13.8KVA in Germany.



**Note3:**

S/N number of the Wi-Fi module is located under the label on the side of the inverter.

Figure 4-27



**Note4:**

Customer can enhance the Wi-Fi signal in order to make the data transmission more stably using the method shown below:

- Step 1** Loosen the cable gland of Wi-Fi antenna;
- Step 2** Pull the Wi-Fi antenna out for about 50~60 mm;
- Step 3** Tighten the cable gland of Wi-Fi antenna.

Figure 4-28

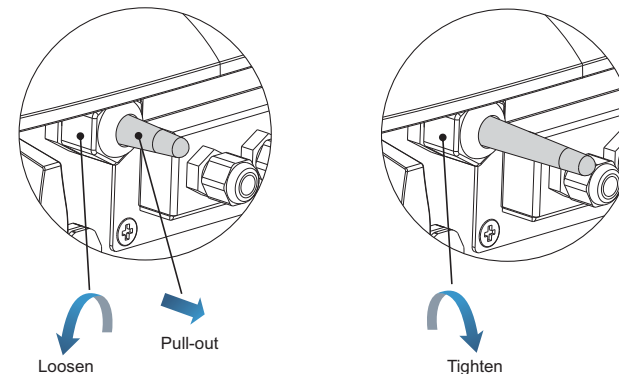

# 5 Commissioning of inverter

## 5.1 Safety inspection before commissioning

|   |  |
|---|--|
|  | <p>Ensure that DC and AC voltages are within the acceptable range of the Sunny Deer series inverter.</p> |
| Attention   |  |

## 5.2 Start inverter

**Step 1:** Turn ON the DC switch.(optional)

**Step 2:** Turn ON the AC circuit breaker.

When the DC power generated by the solar array is adequate, the Sunny Deer series inverter will start automatically. Screen showing “normal” indicates correct operation.

If the inverter indicates any fault, please refer to Section 7.1 of this manual — trouble shooting for help.

# 6 Operation interface

## Outlines of this chapter



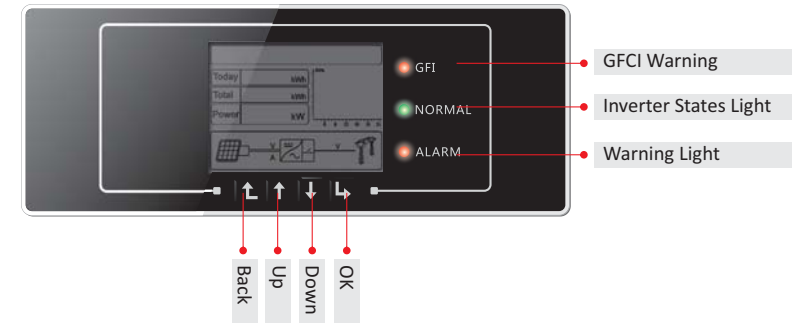

This section introduces the display, operation, buttons and LED indicator lights of Sunny Deer Series Inverter.

## 6.1 Operation and Display Panel

- Buttons and Indicator lights



### Key-button:

- Back : to return to previous menu or enter into main menu from the standard interface.
- Up : to move up or increase value
- Down : to move down or decrease value
- OK : to confirm selection

### Indicator Lights:

- Inverter States Light(GREEN)
  - Flashing: ‘Wait’ or ‘Check’ state
  - ON: ‘Normal’ state
  - OFF: ‘Fault’ or ‘Permanent’ state
- Warning Light (RED)
  - ON: ‘Fault’ or ‘Permanent’ state
  - OFF: ‘Normal’ state
- GFCI Warning Light (RED)
  - ON: ‘ID12: GFCIFault’ or ‘ID20: GFCIDeviceFault’
  - OFF: GFCI normal

## 6.2 Standard Interface

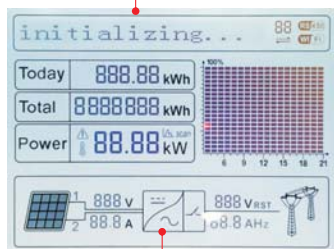

LCD displays the updates of inverter energy、power、input information、warning information etc

- A1 - Indicates modbus communication address. ◦
- A2 - RS485 communicating



- A4 - WIFI communicating
- A3 - Light ON for RS485 communicating

- A5 - Light flashes to warn over frequency and power derating. Light ON to warn remote
- A6 - Indicates today's energy
- A7 - Indicates the total energy

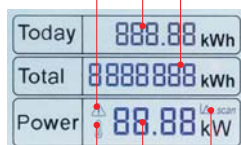

- A10 - MPPT SCAN function is activated (not available)
- A9 - Indicates real time output power
- A8 - Light ON warning for inverter high temperature

- A11 - Light ON when input voltage over 350V
- A12 - Indicates real time input voltage and current channel
- A13 - Indicates the input voltage and current of phase 1&2 and displays in turns in every three seconds
- A14 - Light ON when the state is normal



- A16 - Indicates R/T/S phase current or frequency and displays in turns in every three seconds
- A15 - Indicates R/T/S phase voltage and displays in turns in every three seconds

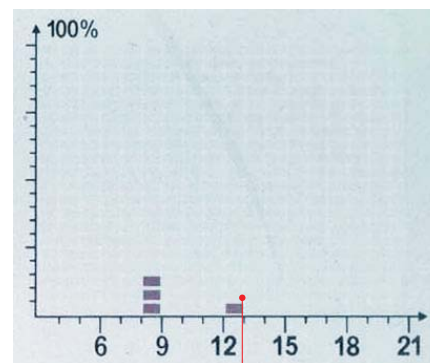

A17 - Indicates the energy from 3:00am-21:00pm in the day

When power-on, LCD interface displays INITIALIZING, refer below picture.

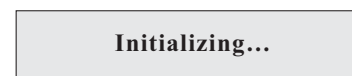

when control board successfully connected with communication board, the LCD display the current state of the inverter display as shown in the figure below.



Waiting States Countdown 10S

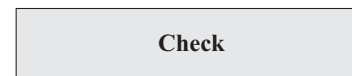

Checking

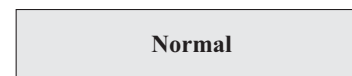

Normal Power Generation

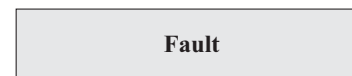

Regular error state



Unrecoverable error state

**Inverter states includes: wait, check, normal, fault and permanent**

**Wait** Inverter is waiting to Check State at the end of reconnection time. In this state, the PV voltage is more than 250V, grid voltage value is between the max and min limits and so on; If not, Inverter will go to Fault State or Permanent State.

**Check:** Inverter is checking isolation resistor, relays, and other safety requirements. It also does self-test to ensure inverter software and hardware are functional. Inverter will go to Fault State or Permanent State if any error or fault occurs.

**Normal** Inverter enter to Normal State it is feeding power to the grid; inverter will go to Fault State or Permanent state if any error or fault occurs.

**Fault** Fault State: Inverter has encountered recoverable error. It should recover if the errors disappear. If Fault State continues; please check the inverter according error code.

**Permanent** Inverter has encountered unrecoverable error, we need maintainer debug this kind of error according to error code.

When the control board and communication board connection fails, the LCD display interface as shown in the figure below.



**6.3 Main Interface**

Press “Back” button under standard interface to enter into main interface, including:

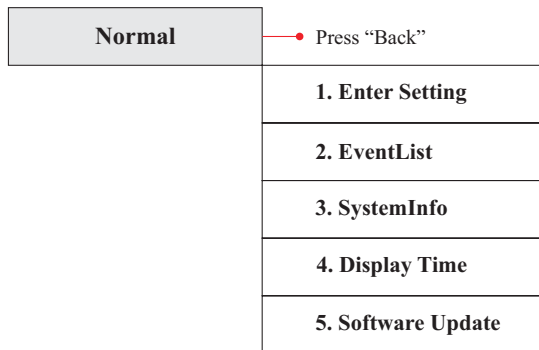

**(A) “Enter Setting” Interface as below:**

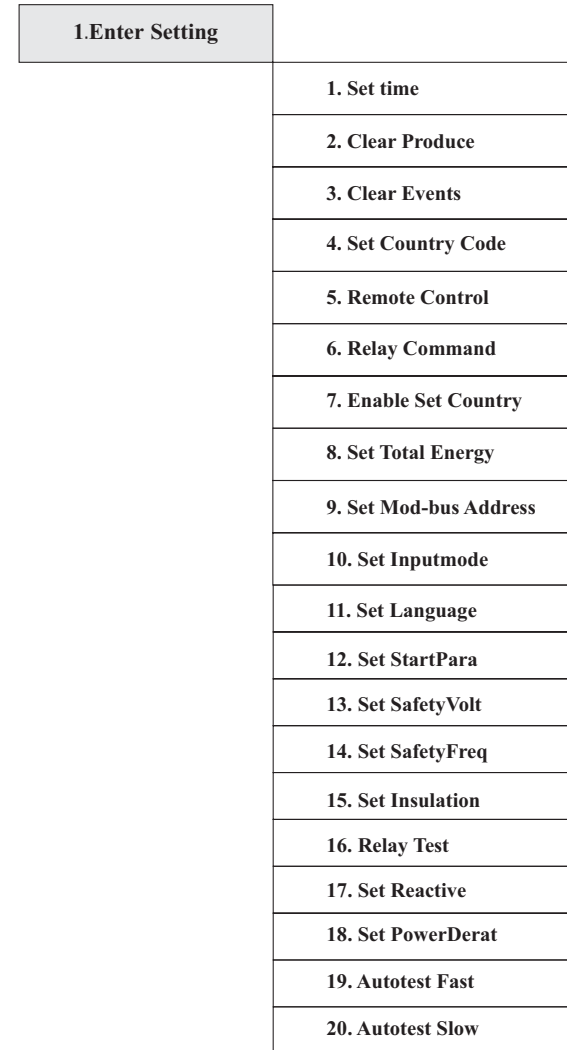

**1. Set Time**

Users press “Back” button to enter “1.Enter Setting” interface, Press “OK” button to enter main setting interface. Enter “1. Set Time” by pressing“Up” button or “Down” button, then press“OK”button and start to set up time.

Time set from year, month, day, minutes, and seconds in turns, “Up” button or “Down”button to choose different value to set each date. Set each value is need to press “OK” button to confirm setting. “success” is displayed if the setting time is correct, “fail” means failure settings.

## 2. Clear Produce

Users press “Back” button to enter “1.Enter Setting” interface, Press “OK” button to enter main setting interface. Then Enter “2.Clear Produce” by pressing “Up” button or “Down” button, press “OK” button and start to clear produce. “success” is displayed after settings.

## 3. Clear Events

Users press “Back” button to enter “1.Enter Setting” interface, Press “OK” button to enter main setting interface. Enter “3. Clear Events” by pressing “Up” button or “Down” button. Press “OK” button and start to clear events. “success” is displayed after settings.

## 4. Set Country Code

Users press “Back” button to enter “1.Enter setting” interface, Press OK button to enter main setting interface. Enter “4.Set Country Code” by pressing “Up” button Or “Down” button, press “OK” button and enter “Input Password” Setting interface. If it's shown "set disable" on the screen, then you can NOT choose the operating country, you should enable country setting through "7. Enable Set Country" interface. If it's shown "set Country code?" on the screen, then press Confirm button to start country setting. "Success" will be shown on the screen after a successful country setting.

Table6-1 country code setting

| code | country              | code | country          | code | country           |
|------|----------------------|------|------------------|------|-------------------|
| 00   | Germany VDE AR-N4105 | 08   | Belgium          | 16   | UK-G83            |
| 01   | Italy CEI0-21        | 09   | UK-G59           | 17   | Greece island     |
| 02   | Australia            | 10   | China            | 18   | EU EN50438        |
| 03   | Spain RD1699         | 11   | France           | 19   | IEC EN61727       |
| 04   | Turkey               | 12   | Poland           | 20   | Korea             |
| 05   | Denmark              | 13   | Germany BDEW     | 21   | Sweden            |
| 06   | Greece Continent     | 14   | Germany VDE 0126 | 22   | Europe General    |
| 07   | Netherland           | 15   | Italy CEI0-16    | 23   | Customer VDE 0126 |

## 5. Remote Control

Users press “Back” button to enter “1.Enter setting” interface, Press OK button to enter main setting interface. Enter “5. Remote Control” by pressing “Up” button or “Down” button. Press “OK” button and enter Remote Control Switch on & off interface. Choose “1.Enable” or “2.Disable” by pressing “Up” button or “Down” button, press “OK” button, then communication board start to transmit control signals to control board. “Success” is displayed after setting success; otherwise it will show “fail”.

## 6. Relay Command

Users press “Back” button to enter “1.Enter setting” interface, Press “OK” button to enter main setting interface. Enter “6. Relay Command” by pressing “Up” button or “Down” button, press “OK” button and enter “Relay Command setting” interface. Choose corresponded setting items by pressing “Up” button or “Down” button, then press “OK” button. “Success” or “fail” is displayed after setting.

|                        |                              |
|------------------------|------------------------------|
| <b>6.Relay Command</b> |                              |
|                        | <b>1.Production</b>          |
|                        | <b>2.Alarm</b>               |
|                        | <b>3.Alarm (alarmconfig)</b> |
|                        | <b>4.Relay Disable</b>       |

### Relay Command Definition:

|                            |  |
|----------------------------|--|
| <b>Production</b>          | <p>the relay switches whenever a connection to (and therefore a disconnection from) the grid occurs.</p> <p>If the relay contractor is in normally open (close) mode, the contact will stay open (or closed) until the inverter is connected to the grid; once the inverter connects to the grid and starts to export power, the relay switches state and therefore closes (or opens).</p> <p>When the inverter disconnects from the grid, the relay contact returns to its position of rest, namely open (or closed).</p> |
| <b>Alarm</b>               | <p>The relay switches whenever there is an alarm on the inverter (Error). No switching occurs when there is a Warning.</p> <p>If the relay contractor is in normally open(close)mode, the contact will stay open (or closed) until the inverter reports an error; once the inverter reports an error, the relay switches state and therefore closes (or opens).The contact remains switched from its rest condition until normal operation is restored.</p>  |
| <b>Alarm (alarmconfig)</b> | <p>the relay switches whenever there is an alarm (Error) or a Warning, which have been previously selected by the user through the PC. the contact will stay open (or closed) until the inverter reports an error or a warning out of those selected from the menu; once the inverter displays an error or a warning out of those selected, the relay switches state and therefore closes (or opens) the contact. The relay remains switched from its rest condition until the alarm or warning has disappeared.</p>       |
| <b>Relay Disable</b>       | Control function is forbidden  |



## 7. Enable Set Country

Users press Back button to enter “1.Enter setting” interface, Press OK button to enter main setting interface. Enter “7.Enable Set Country” by pressing “Up” button Or “Down” button, press “OK” button and enter “Input Password” Setting interface. Press “Back” button to set passwords (default: 0001), increase or decrease value though pressing “Up” button or “Down” button, press “OK” button to next value setting. “Error!” Try again” will be displayed for wrong passwords. Press “Back” button and rekey in the correct passwords. “Success” will be displayed if setting successfully.

Attention: when inverter working for power generation over 24h, country setting is forbidden, it can only be set after LCD setting. Key in passwords for country setting through LCD (default: 0001), country setting can be set in 24h after keying in the correct passwords, over 24h, set through LCD again.

## 8. Set Total Energy

Users press Back button to enter “1.Enter setting” interface, Press OK button to enter main setting interface. Enter “8. Set Total Energy” by pressing “Up” button or “Down” button , then press “OK” button and enter “Input Password” Setting interface. Press “OK” button to set passwords (default: 0001), increase or decrease value though pressing “Up” button or “Down” button, press “OK” button to confirm the value and to next value setting. “Error! Try again” will be displayed for wrong passwords. Press “Back” button and rekey in the correct passwords then set total energy. “Success” or “fail” is displayed after setting.

## 9. Set mod-bus address

Users press “Back” button to enter “1.Enter setting” interface, Press “OK” button to enter main setting interface. Enter “9. Set mod-bus address” by pressing “Up” button or “Down” button. Press “OK” button and enter setting interface. Choose corresponded setting items by pressing “Up” button or “Down” button, then press “OK” button. “Success” or “fail” is displayed after setting.

## 10. Set input mode

Input mode selection: Sunny Deer Series inverter has 2 MPPT channels, the 2 MPPT can operate independently, also can operate in parallel. If the PV strings are connected in parallel outside the inverter, you should choose the "in parallel mode", otherwise use the default setting. Press “Back” button to enter “1.Enter setting” interface, press “OK” button to enter main setting interface. Enter “10. Set inputmode” by pressing “Up” or “Down” buttons. Press “OK” button to enter setting interface. Choose “In parallel Mode?” or “Independent Mode?” by pressing “Up” or “Down” buttons, then press “OK” button. “Success” or “fail” is displayed after setting.

## 11. Set Language

Users press “Back” button to enter “1.Enter setting” interface, Press “OK” button to enter main setting interface. Enter “11. Set Language” by pressing “Up” button or “Down” button. Press “OK” button and enter setting interface. Choose corresponded setting items by pressing “Up” button or “Down” button, then press “OK” button. “Success” or “fail” is displayed after setting.

## 12. Set StartPara

User can change the start parameter by the LCD. First the User need to copy the. TXT file which is used to change the start parameter to the SD card .

Users press Back button to enter “1.Enter setting” interface, Press OK button to enter main setting interface. Enter “12. Set StartPara” by pressing “Up” button Or “Down” button, press “OK” button and enter “Input Password” Setting interface. Press “Back” button to set passwords (default: 0001), increase or decrease value though pressing “Up” button or “Down” button, press “OK” button to next value setting. “Error!” Try again” will be displayed for wrong passwords. Press “Back” button and rekey in the correct passwords. “Success” will be displayed if setting successfully.

## 13. Set SafetyVolt

User can change the Voltage protection point by the LCD. First the User need to copy the. TXT file which is used to change the Voltage protection point to the SD card .

Users press Back button to enter “1.Enter setting” interface, Press OK button to enter main setting interface. Enter “13. Set SafetyVolt” by pressing “Up” button Or “Down” button, press “OK” button and enter “Input Password” Setting interface. Press “Back” button to set passwords (default: 0001), increase or decrease value though pressing “Up” button or “Down” button, press “OK” button to next value setting. “Error!” Try again” will be displayed for wrong passwords. Press “Back” button and rekey in the correct passwords. “Success” will be displayed if setting successfully.

## 14. Set SafetyFreq

User can change the Frequency protection point by the LCD. First the User need to copy the. TXT file which is used to change the Frequency protection point to the SD card .

Users press Back button to enter “1.Enter setting” interface, Press OK button to enter main setting interface. Enter “14. Set SafetyFreq” by pressing “Up” button Or “Down” button, press “OK” button and enter “Input Password” Setting interface. Press “Back” button to set passwords (default: 0001), increase or decrease value though pressing “Up” button or “Down” button, press “OK” button to next value setting. “Error!” Try again” will be displayed for wrong passwords. Press “Back” button and rekey in the correct passwords. “Success” will be displayed if setting successfully.

## 15. Set Insulation

User can change the Insulation protection point by the LCD. First the User need to copy the. TXT file which is used to change the Insulation protection point to the SD card .

Users press Back button to enter “1.Enter setting” interface, Press OK button to enter main setting interface. Enter “15. Set Insulation” by pressing “Up” button Or “Down” button, press “OK” button and enter “Input Password” Setting interface. Press “Back” button to set passwords (default: 0001), increase or decrease value though pressing “Up” button or “Down” button, press “OK” button to next value setting. “Error!” Try again” will be displayed for wrong passwords. Press “Back” button and rekey in the correct passwords. “Success” will be displayed if setting successfully.

## 16. Relay Test

Users press Back button to enter “1.Enter setting” interface, Press OK button to enter main setting interface. Enter “16. Relay Test” by pressing “Up” button Or “Down” button, then press “OK” button and start test relay. “Success” will be displayed if setting successfully.

## 17. Set Reactive

Users press “Back” button to enter “1.Enter Setting” interface, Press “OK” button to enter main setting interface. Enter “17.Set Reactive” by pressing “Up” button or “Down” button, press “OK” button and enter “Input Password” Setting interface.



**17. Set Reactive**

Users press "Back" button to enter "1.Enter Setting" interface, Press "OK" button to enter main setting interface. Enter "17.Set Reactive" by pressing "Up" button or "Down" button, press "OK" button and enter "Input Password" Setting interface.

Press "Back" button to set passwords (default: 0001), increase or decrease value though pressing "Up" button or "Down" button, press "OK" button to next value setting. "Error! Try again" will be displayed for wrong passwords. Press "Back" button and rekey in the correct passwords. "success" will be displayed if setting successfully,

**18. Set PowerDerat**

Users press "Back" button to enter "1.Enter Setting" interface, Press "OK" button to enter main setting interface. Enter "18.Set PowerDerat" by pressing "Up" button or "Down" button, press "OK" button and enter "Input Password" Setting interface.

Press "Back" button to set passwords (default: 0001), increase or decrease value though pressing "Up" button or "Down" button, press "OK" button to next value setting. "Error! Try again" will be displayed for wrong passwords. Press "Back" button and rekey in the correct passwords. "success" will be displayed if setting successfully,

**19. Autotest Fast**

Users press "Back" button to enter "1.Enter setting" interface, Press OK button to enter main setting interface. Enter "19. Autotest Fast" by pressing "Up" button Or "Down" button, then press "OK" button and enter "Start Autotest" interface. Then press Confirm button to start Autotest.

The autotest results are stored in "Itaiy" folder of the SD card

**20. Autotest Slow**

Users press "Back" button to enter "1.Enter setting" interface, Press OK button to enter main setting interface. Enter "20. Autotest Slow" by pressing "Up" button Or "Down" button, then press "OK" button and enter "Start Autotest" interface. Then press Confirm button to start Autotest.

The autotest results are stored in "Itaiy" folder of the SD card

**(B) "Event List" Interface as below:**

Event List is used to display the real-time event records, including the total number of events and each specific ID No. and happening time. User can enter Event List interface through main interface to check details of real-time event records, Event will be listed by the happening time, and recent events will be listed in the front. Please refer to below picture: Users press "Back" button and "Down" button in standard interface, then enter into 2.EventList" interface.

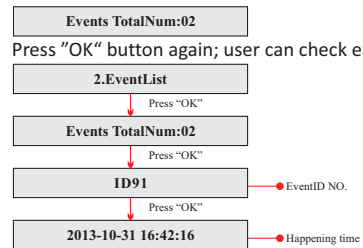

Press "OK" button again; user can check each event ID number and happening time, see below:

**(C) "SystemInfo" Interface as below:**

|                     |                        |
|---------------------|------------------------|
| <b>3.SystemInfo</b> |                        |
|                     | <b>1.Inverter Type</b> |
|                     | <b>2.Serial Number</b> |
|                     | <b>3.SoftVersion</b>   |
|                     | <b>4.HardVersion</b>   |
|                     | <b>5.Country</b>       |
|                     | <b>6.Input Mode</b>    |
|                     | <b>7.Relay Command</b> |
|                     | <b>8.Power Factor</b>  |

**Step 2** Remove the waterproof cover, Press SD card inside in the position marked SD card. Then the SD card will automatically pop up.

Figure 6-2

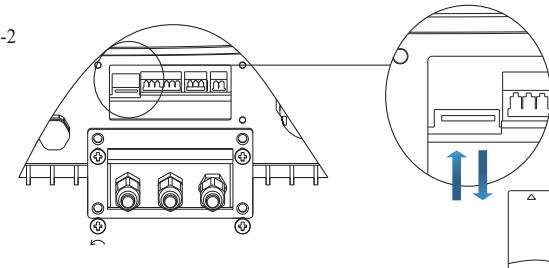

**Step 3** The SD card reader must be ready by the users, so that SD card so easy to establish the connection with the computer.

**Step 4** SOFAR SOLAR will send the Software code to the user who needs to update. After user receive the file, please decompressing file and cover the original file in SD card.

**Step 5** Insert the SD card into the SD card slot, there will be a faint clicking sound typically, indicating that has stuck.

**Step 6** Then turn on DC switch and enter into the online upgrade to the main menu "5. Software Update" in the LCD display program[6.3(E)]. The method to enter the menu can refer to operation interface of LCD.

**Step 7** Input the password, if password is correct, and then begin the update process, the original password is 0001.

**Step 8** System update main DSP、 slave DSP and ARM in turns. If main DSP update success ,the LCD will display “Update DSP1 Success”, otherwise display “Update DSP1 Fail”; If slave DSP update success ,the LCD will display “Update DSP2 Success”, otherwise display “Update DSP2 Fail”

**Step 9** If Fail , please turn off the DC breaker, wait for the LCD screen extinguish, then turn on the DC breaker again, then Continue to update from step 6.

**Step 10** After the update is completed, turn off the DC breaker, wait for the LCD screen extinguish, then recover the communication waterproof and then turn on the DC breaker and AC breaker again, the inverter will enters the running state.

**1. Inverter Type**

Users press “Back” button and “Up” button or “Down” button enter “3. SystemInfo” interface, Press “OK” button to enter enter into system information checking interface,then press “Up” button or “Down” button enter into “1. Inverter Type”,then press “OK” button the Inverter Type will be displayed.

**2. Serial Number**

Users press “Back” button and “Up” button or “Down” button to enter “3. SystemInfo” interface, Press “OK” button to enter enter into system information checking interface,then press “Up” button or “Down” button enter into “2. Serial Number”,then press “OK” button ,the serial number will be displayed.

**3. SoftVersion**

Users press “Back” button and “Up” button or “Down” button to enter “3. SystemInfo” interface, then Press “OK” button to enter enter into system information checking interface,then press “Up” button or “Down” button enter into “3. SoftVersion”,then press “OK” button the SoftVersion will be displayed.

**4. HardVersion**

Users press “Back” button and “Up” button or “Down” button to enter “3. SystemInfo” interface, then Press “OK” button to enter enter into system information checking interface,then press “Up” button or “Down” button enter into “4. HardVersion”,then press “OK” button the HardVersion will be displayed.

**5. Country**

Users press “Back” button and “Up” button or “Down” button to enter “3. SystemInfo” interface, then Press “OK” button to enter enter into system information checking interface,then press “Up” button or “Down” button enter into “5. Country”,then press “OK” button the Country will be displayed.

**6. Input Mode**

Press “Back” button and “Up” or “Down” button to enter “3. System Info” interface, then Press “OK” button to enter into system information checking interface, then press “Up” or “Down” button enter into “6. Input Mode”, then press “OK” button, the Input Mode will be displayed.

**7. Relay Command**

Users press “Back” button and “Up” button or “Down” button to enter “3. SystemInfo” interface, then Press “OK” button to enter enter into system information checking interface,then press “Up” button or “Down” button enter into “7. Relay Command”,then press “OK” button the Relay Command Mode will be displayed.

**8.Power Factor**

Users press “Back” button and “Up” button or “Down” button to enter “3. SystemInfo” interface, then Press “OK” button to enter enter into system information checking interface,then press “Up” button or “Down” button enter into “8. Power Factor”,then press “OK” button the Power Factor will be displayed.

**(D) Display Time**

Press the “Back” button and “Up” button or “Down” key in the standard user interface to enter into “4.Display Time”,then press “OK” button to display the current system time.

**(E) Software Update**

Press the “Back” button and “Up” button or “Down” button in the standard user interface to enter into “5. Software Update”, then press “OK” button to enter into the “input password” interface, now press the “OK” button to input the password(initial passwords is 0001),Press the “Up” and “Down” button to change the value, then press “OK” button to confirm the current value of input and enter the next set of value .when set over, if the password is wrong the LCD will display “Error! Try again”, at this time ,you should re-enter your password .If the password is correct then begin the update process.

**6.4 Update Software online**

Sunny Deer series inverters offer software upgrade via SD card to maximize inverter performance and avoid inverter operation error caused by software bugs.

**Procedure:**

**Step 1** first, turn off the DC and AC breaker, and then remove the communication waterproof cover as the following picture. If the communication lines (RS485, Relays, I/O) has been connected, Be sure to release the waterproof nut, Make sure the communication line is no longer the force. Then remove the waterproof cover, In order to avoid loosening the communication plug which has been connected.

Figure 6-1

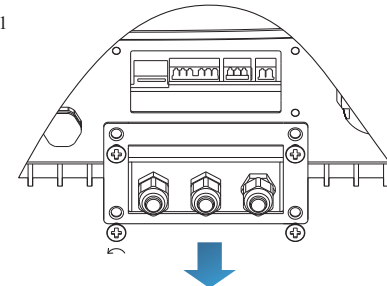

# Trouble shooting and maintenance

## Outlines of this chapter

This topic describes how to perform daily maintenance and troubleshooting to ensure long term proper operation of the Sunny Deer series inverter.

### 7.1 Trouble shooting

This section contains information and procedures for solving possible problems with Sunny Deer series inverter.

© This section help users to identify the inverter fault. Please read the following procedures carefully:

- Check the warning, fault messages or fault codes shown on the inverter screen, record all the fault information.
- If there is no fault information shown on the screen, check whether the following requirements are met:
  - Is the inverter mounted in a clean, dry place with good ventilation?
  - Is the DC switch turned ON?
  - Are the cables adequately sized and short enough?
  - Are the input and output connections and wiring in good condition?
  - Are the configuration settings correct for the particular installation?
  - Are the display panel and the communication cables properly connected and undamaged?

Follow the steps below to view recorded problems:

Press “back” to enter the main menu from the standard interface. Select “2. Event List”, then press “OK” to enter event list.

#### © EventList information

Table 7-1 Eventlist

| EventList NO. | EventList Name | EventList description                | solution   |
|---------------|----------------|--------------------------------------|--|
| ID01          | GridOVP        | The power grid voltage is too high   | <ul style="list-style-type: none"> <li>• If the alarm occurs occasionally, the possible cause is that the electric grid is abnormal occasionally. SOFAR inverter automatically returns to normal operating status when the electric grid's back to normal.</li> <li>• If the alarm occurs frequently, check whether the grid voltage/frequency is within the acceptable range. If no, contact SOFAR technical support. If yes, check the AC circuit breaker and AC wiring of the SOFAR inverter.</li> <li>• If the grid voltage/frequency is within the acceptable range and AC wiring is correct, while the alarm occurs repeatedly, contact SOFAR technical support to change the grid over-voltage, under-voltage, over-frequency, under-frequency protection points after obtaining approval from the local electrical grid operator.</li> </ul> |
| ID02          | GridUVP        | The power grid voltage is too low    |  |
| ID03          | GridOFP        | The power grid frequency is too high |  |
| ID04          | GridUFP        | The power grid frequency is too low  |  |

|      |                  |   |  |
|------|------------------|---|--|
| ID05 | PVUVP            | The input voltage is too low  | Check whether too few PV modules are series connected in a PV string, thus the voltage(Vmp) of the PV string is lower than the minimum operating voltage of SOFAR inverter. If yes, adjust the number of series connected PV modules to increase the voltage of the PV string to fit the input voltage range of SOFAR inverter. SOFAR inverter automatically returns to normal operating status after correct adjustments.   |
| ID09 | PvOVP            | The input voltage is too high                                       | Check whether too many PV modules are series connected in a PV string, thus the voltage(Voc) of the PV string is higher than the maximum input voltage of SOFAR inverter. If yes, adjust the number of series connected PV modules to decrease the voltage of the PV string to fit the input voltage range of SOFAR inverter. SOFAR inverter automatically returns to normal operating status after correct adjustments.   |
| ID10 | IpvUnbalance     | Input current is not balanced                                       | Check the input mode(parallel mode/ independent mode) setting of SOFAR inverter according to Section 6.3 (C) 6.Input Mode of this user manual. If it's incorrect, change it according to Section 6.3 (A) 10.Set Input mode of this manual.   |
| ID11 | PvConfigSetWrong | Incorrect input mode  |  |
| ID12 | GFCIFault        | GFCI Fault  | <ul style="list-style-type: none"> <li>• If the fault occurs occasionally, the possible cause is that the external circuits are abnormal occasionally. SOFAR inverter automatically returns to normal operating status after the fault is rectified.</li> <li>• If the fault occurs frequently and lasts a long time, check whether the insulation resistance between the PV array and earth(ground) is too low, then check the insulation conditions of PV cables.</li> </ul> |
| ID14 | HwBoostOCP       | The input current is too high, and has happened hardware protection | Check whether the input current is higher than the maximum input current of SOFAR inverters, then check the input wiring, if both are correct, please contact SOFAR technical support.   |
| ID15 | HwAcOCP          | The grid current is too high, and has happened hardware protection  | ID15-ID24 are internal faults of SOFAR inverter, turn OFF the “DC switch”, wait for 5 minutes, then turn ON the “DC switch”. Check whether the fault is rectified. If no, please contact SOFAR technical support.  |
| ID16 | AcRmsOCP         | The grid current is too high  |  |
| ID17 | HwADFaultGrid    | The grid current sampling error                                     |  |
| ID18 | HwADFaultDCI     | The DCI sampling error  |  |
| ID19 | HwADFaultVGrid   | The grid voltage sampling error                                     |  |
| ID20 | GFCIDeviceFault  | The GFCI sampling error   |  |
| ID21 | MChip_Fault      | The master chip fault   |  |
| ID22 | HwAuxPowerFault  | The auxiliary voltage error   |  |
| ID23 | BusVoltZeroFault | The bus voltage sampling error                                      |  |
| ID24 | IacRmsUnbalance  | The Output current is not balanced                                  |  |
| ID25 | BusUVP           | The bus voltage is too low  |  |

|             |                       |  |   |  |
|-------------|-----------------------|--|---|--|
| <b>ID26</b> | BusOVP                | The bus voltage Is too high  | ID26-ID27 are internal faults of SOFAR inverter, turn OFF the "DC switch", wait for 5 minutes, then turn ON the "DC switch". Check whether the fault is rectified. If no, please contact SOFAR technical support. |  |
| <b>ID27</b> | VbusUnbalance         | The bus voltage is not balanced  |   |  |
| <b>ID28</b> | DciOCP                | The Dci is too high  |   |  |
| <b>ID29</b> | SwOCPInstant          | The grid current is too high   | Internal faults of SOFAR inverter, turn OFF the "DC switch", wait for 5 minutes, then turn ON the "DC switch". Check whether the fault is rectified. If no, please contact SOFAR technical support.               |  |
| <b>ID30</b> | SwBOCPInstant         | The input current is too high  | Check whether the input current is higher than the maximum input current of SOFAR inverters, then check the input wiring, if both are correct, please contact SOFAR technical support.                            |  |
| <b>ID49</b> | ConsistentFault_VGrid | The grid voltage sampling value between the master DSP and slave DSP is not consistent   | ID49-ID55 are internal faults of SOFAR inverter, turn OFF the "DC switch", wait for 5 minutes, then turn ON the "DC switch". Check whether the fault is rectified. If no, please contact SOFAR technical support. |  |
| <b>ID50</b> | ConsistentFault_FGrid | The grid frequency sampling value between the master DSP and slave DSP is not consistent |   |  |
| <b>ID51</b> | ConsistentFault_DCI   | The DCI sampling value between the master DSP and slave DSP is not consistent            |   |  |
| <b>ID52</b> | ConsistentFault_GFCI  | The GFCI sampling value between the master DSP and slave DSP is not consistent           |   |  |
| <b>ID53</b> | SpiCommLose           | The spi communication between the master DSP and slave DSP is fault                      |   |  |
| <b>ID54</b> | SciCommLose           | The Sci communication between the control board communication board is fault             |   |  |
| <b>ID55</b> | RelayTestFail         | The relays fault   |   |  |
| <b>ID56</b> | PvIsoFault            | The insulation resistance is too low   |   | Check the insulation resistance between the PV array and earth(ground), if a short circuit occurs, rectify the fault.  |
| <b>ID57</b> | OverTempFault_Inv     | The inverter temp is too high  |   | <ul style="list-style-type: none"> <li>Ensure the installation position and installation method meet the requirements of Section 3.4 of this user manual.</li> </ul>                                   |
| <b>ID58</b> | OverTempFault_Boost   | The Boost temp is too high   |   | <ul style="list-style-type: none"> <li>Check whether the ambient temperature of the installation position exceeds the upper limit. If yes, improve ventilation to decrease the temperature.</li> </ul> |
| <b>ID59</b> | OverTempFault_Env     | The environment temp is too high   |   |  |
| <b>ID65</b> | UnrecoverHwAcOCP      | The grid current is too high, and has cause unrecoverable hardware fault                 | ID65-ID70 are internal faults of SOFAR inverter, turn OFF the "DC switch", wait for 5 minutes, then turn ON the "DC switch". Check whether the fault is rectified. If no, please contact SOFAR technical support. |  |

|             |                                    |  |  |
|-------------|------------------------------------|--|--|
| <b>ID66</b> | UnrecoverBusOVP                    | The bus voltage is too high, and has cause unrecoverable fault                       |  |
| <b>ID67</b> | UnrecoverIacRmsUnbalance           | The grid current is unbalance, and has cause unrecoverable fault                     |  |
| <b>ID68</b> | UnrecoverIpvUnbalance              | The input current is unbalance, and has cause unrecoverable fault                    |  |
| <b>ID69</b> | UnrecoverVbusUnbalance             | The bus voltage Is unbalance, and has cause unrecoverable fault                      |  |
| <b>ID70</b> | UnrecoverOCPInstant                | The grid current is too high, and has cause unrecoverable fault                      | Check the input mode(parallel mode/ independent mode) setting of SOFAR inverter according to Section 6.3 (C) 6.Input Mode of this user manual, If it's incorrect, change it according to Section 6.3 (A) 10.Set Input mode of this manual.   |
| <b>ID71</b> | UnrecoverPvConfigSetWrong          | Incorrect input mode   |  |
| <b>ID74</b> | UnrecoverIPVInstant                | The input current is too high, and has happen unrecoverable fault                    |  |
| <b>ID75</b> | UnrecoverWRITEEPROM                | The EEPROM is unrecoverable  |  |
| <b>ID76</b> | UnrecoverREADEEPROM                | The EEPROM is unrecoverable  |  |
| <b>ID77</b> | UnrecoverRelayFail                 | Relay has happen permanent fault   | <ul style="list-style-type: none"> <li>Ensure the installation position and installation method meet the requirements of Section 3.4 of this user manual.</li> <li>Check whether the ambient temperature of the installation position exceeds the upper limit. If yes, improve ventilation to decrease the temperature.</li> </ul> |
| <b>ID81</b> | OverTempDerating                   | the inverter has derated because of the temperature is too high                      |  |
| <b>ID82</b> | OverFreqDerating                   | the inverter has derated because of the grid frequency too high                      |  |
| <b>ID83</b> | RemoteDerating                     | The inverter has derated by the Remote control                                       | SOFAR inverter records ID83 in case of remote power derating operation. Check the wiring of remote input and output control signal port on the communication board according to Section 4.5 of this user manual.   |
| <b>ID84</b> | RemoteOff                          | The inverter has shut down because by the Remote control                             | SOFAR inverter records ID84 in case of remote shutdown operation. Check the wiring of remote input and output control signal port on the communication board according to Section 4.5 of this user manual.   |
| <b>ID94</b> | Software version is not consistent | The Software between the control board and the communication board is not consistent | Contact SOFAR technical support to upgrade software.   |
| <b>ID95</b> | Communication board EEPROM fault   | The Communication board EEPROM is fault  | ID95-ID96 are internal faults of SOFAR inverter, turn OFF the "DC switch", wait for 5 minutes, then turn ON the "DC switch". Check whether the fault is rectified. If no, please contact SOFAR technical support.  |
| <b>ID96</b> | RTC clock chip anomaly             | RTC clock chip is fault  |  |
| <b>ID97</b> | Invalid Country                    | The Country is InValid   | Check the country setting according to Section 6.3 (C) 5.Country of this user manual, If it's incorrect, change it according to Section 6.3 (A) 4.Set Country Code of this manual.   |
| <b>ID98</b> | SD fault                           | The SD card is fault   | Please replace the SD card.  |

## 7.2 Maintenance

Inverters generally do not need any daily or routine maintenance. Heat sink should not be blocked by dust, dirt or any other items.

Before the cleaning, make sure that the DC SWITCH is turned OFF and the circuit breaker between SOFAR inverter and electrical grid is turned OFF. Wait at least for 5 minutes before the cleaning.

### ◦ Inverter cleaning

Please clean the inverter with an air blower, a dry & soft cloth or a soft bristle brush. Do NOT clean the inverter with water, corrosive chemicals, detergent, etc.

### ◦ Heat sink cleaning

For the long-term proper operation of SOFAR inverters, ensure there is enough space around the heat sink for ventilation, check the heat sink for blockage (dust, snow, etc.) and clean them if they exist. Please clean the heat sink with an air blower, a dry & soft cloth or a soft bristle brush. Do NOT clean the heat sink with water, corrosive chemicals, detergent, etc.

# 8 Technical data

## Outlines of this chapter

This topic lists the technical specifications for all Sunny Deer series inverters.

### 8.1 Input parameters (DC)

| Technical Data                            | SOFAR 3000TLM    | SOFAR 3680TLM    | SOFAR 4000TLM    | SOFAR 4600TLM    | SOFAR 5000TLM |
|---|------------------|------------------|------------------|------------------|---------------|
| Max. input power                          | 3100W            | 3800W            | 4160W            | 4800W            | 5200W         |
| Max DC power for single MPPT              | 2000W(200V-500V) | 2400W(200V-500V) | 2600W(200V-500V) | 3000W(200V-500V) |               |
| Number of independent MPPT                | 2                |                  |                  |                  |               |
| Number of DC inputs                       | 1 for each MPPT  |                  |                  |                  |               |
| Max input voltage                         | 600V             |                  |                  |                  |               |
| Start-up input voltage                    | 100V (+/-5V)     |                  |                  |                  |               |
| Rated input voltage                       | 360V             |                  |                  |                  |               |
| Operating input voltage range             | 100V-550V        |                  |                  |                  |               |
| MPPT voltage range                        | 160V-500V        | 165V-500V        |                  |                  | 175V-500V     |
| Max input MPPT current                    | 10A/10A          | 12A/12A          | 13A/13A          | 15A/15A          |               |
| Input short circuit current for each MPPT | 12A              | 14A              | 16A              | 18A              |               |

### 8.2 Output parameters (AC)

| Technical Data                | SOFAR 3000TLM          | SOFAR 3680TLM | SOFAR 4000TLM | SOFAR 4600TLM | SOFAR 5000TLM |
|-------------------------------|------------------------|---------------|---------------|---------------|---------------|
| Rated power (@230V, 50Hz)     | 3000VA                 | 3680VA        | 4000VA        | 4600VA        | 5000VA        |
| Max AC power                  | 3000VA                 | 3680VA        | 4000VA        | 4600VA        | 5000VA        |
| Nominal AC voltage            | L/N/PE, 220, 230, 240  |               |               |               |               |
| Nominal AC voltage range      | 180V-270V              |               |               |               |               |
| Grid frequency range          | 44~55Hz / 54~66Hz      |               |               |               |               |
| Active power adjustable range | 0% 100%                |               |               |               |               |
| Max output current            | 13A                    | 16A           | 17.5A         | 20A           | 22A           |
| THDi                          | <3%                    |               |               |               |               |
| Power factor                  | 1 (adjustable +/- 0.8) |               |               |               |               |

### 8.3 Efficiency, Protection and Communication

| Technical Data                              | SOFAR 3000TLM  | SOFAR 3680TLM | SOFAR 4000TLM | SOFAR 4600TLM | SOFAR 5000TLM |
|---|--|---------------|---------------|---------------|---------------|
| Max efficiency                              | 97.6%  |               |               |               |               |
| Weighted eff. (EU/CEC)                      | 97.1% / 97.3%  |               |               |               |               |
| Self-consumption at night                   | <1w  |               |               |               |               |
| Feed-in start power                         | 50W  |               |               |               |               |
| MPPT efficiency                             | >99.5%   |               |               |               |               |
| DC switch                                   | Option   |               |               |               |               |
| Safety protection                           | Anti islanding, RCMU, Ground fault monitoring  |               |               |               |               |
| Certification                               | AS4777, VDE0126-1-1, G83/2, G59/3, C10/11, RD1699, UTEC15-712-1, EN50438, VDE-AR-N4105 |               |               |               |               |
| Communication                               | Wifi + RS485+Multi-function relay+I/O  |               |               |               |               |
| Protective class                            | Class I  |               |               |               |               |
| External environment pollution degree       | Degree 3   |               |               |               |               |
| Overvoltage category                        | PV: OVC II, AC mains: OVC III  |               |               |               |               |
| Max inverter Back-feed current to the array | 0A   |               |               |               |               |
| Output short circuit current and duration   | 200A/1us   |               |               |               |               |
| Output inrush current and duration          | 0.8A/2us   |               |               |               |               |

### 8.4 General Data

| Technical Data                    | SOFAR 3000TLM                          | SOFAR 3680TLM | SOFAR 4000TLM | SOFAR 4600TLM | SOFAR 5000TLM |
|-----------------------------------|--|---------------|---------------|---------------|---------------|
| Ambient temperature range         | - 25°C ~ + 60°C (above 45 °C derating) |               |               |               |               |
| Topology                          | Transformerless                        |               |               |               |               |
| Degree of protection              | IP65                                   |               |               |               |               |
| Allowable relative humidity range | 0~100%                                 |               |               |               |               |
| Max operating altitude            | 2000m                                  |               |               |               |               |
| Noise                             | <25dB                                  |               |               |               |               |
| Weight                            | 18kg                                   |               |               | 19kg          |               |
| Cooling                           | Nature                                 |               |               |               |               |
| Dimension                         | 478*344*170mm                          |               |               |               |               |
| Warranty                          | 5 years                                |               |               |               |               |

# 9) Sofar SolarMAN Quick\_Setup Manual (Wi-Fi Optional)

## Outlines of this chapter

This quick guide is intended to assist users in quick configuration and start of Embedded Wi-Fi module.

### 9.1 Network setting



The setting hereinafter is operated with Windows7 for reference only. If other operating systems are used, please follow the corresponding procedures.

#### Note

1. Prepare a computer or device, e.g. tablet PC and smart phone that enables Wi-Fi.
2. Obtain an IP address automatically.

#### Procedure:

Step1: Click on ;

Step2: Connect with your personal internet access point (AP) or WLAN.

Example: "sofarpv" in this case. See Figure 9-1

Step3: Right click on your connected AP, click on Status > Properties to open the wireless network property setup window. See Figure 9-2

Figure 9-1

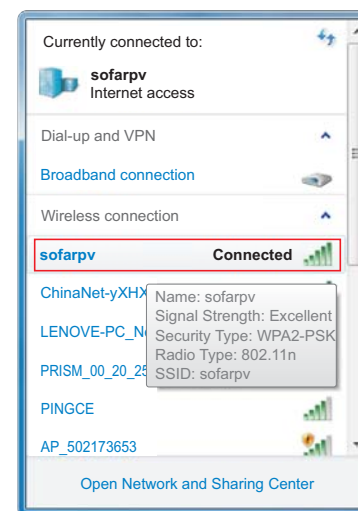
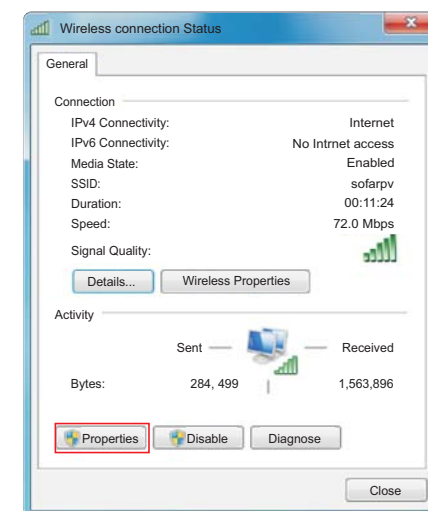

Figure 9-2





**Setp4:** Double click on internet Protocol Version 4 (TCP/IPv4). Click on General > Obtain an IP address automatically > OK to finish the setup. See Figure 9-3, 9-4:

Figure 9-3

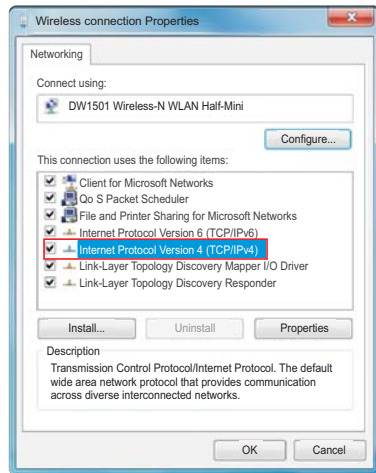
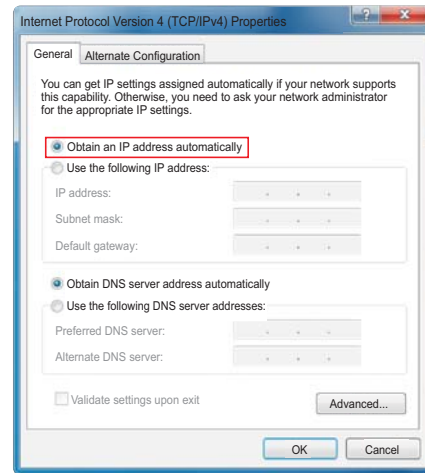

Figure 9-4



### 3. SOFAR inverter Wi-Fi module setup

#### Procedure:

**Setp1:** Click on ;

**Setp2:** Connect with SOFAR inverter Wi-Fi module, defaulted with no password and its name started as AP\_ and a following 9-digit Wi-Fi serial number. See Figure 9-5, 9-6.

Example: AP\_502173653

Figure 9-5



Figure 9-6

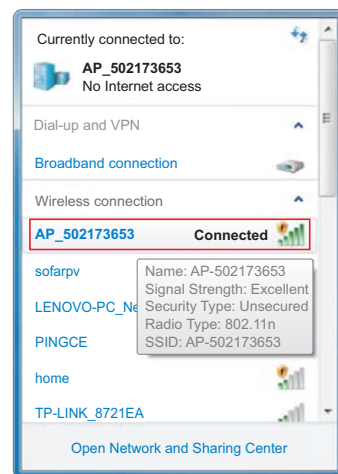

**Setp3:** When connected, open browser, head to <http://10.10.100.254/>, and fill in user name and password which all defaulted as admin for the first time. See Figure 9-7

Figure 9-7



**Browsers like internet Explorer 8+, chrome 15+ and Firefox 10+ are recommended.**

#### Note

**Setp4:** When successfully logged in, users can find basic information on their inverter Wi-Fi module.

Figure 9-8

| Status   | Device information                                      |
|----------|---|
| Wizard   | Device serial number: 502173653                         |
| Wireless | Firmware version: H4.01.43Y4.0.01W1.0.13(2014-07-161-S) |
| Cable    | Wireless SP mode: Enable                                |
| Advanced | SSID: AP_502173653                                      |
| Account  | IP address: 10.10.100.254                               |
| Update   | MAC address: 00:95:69:1A:33:30                          |
| Restart  | Wireless STA mode: Enable                               |
| Reset    | Router SSID: sofarsolar                                 |
|          | Signal Quality: 0%                                      |
|          | IP address: 0.0.0.0                                     |
|          | MAC address: 00:95:69:1A:33:31                          |
|          | Cable mode: Enable                                      |
|          | IP address: 0.0.0.0                                     |
|          | MAC address: 00:95:69:1A:33:31                          |
|          | Connected Inverter                                      |



**Setp5:** Please click on Wizard > Start to start the detailed setup on your inverter Wi-Fi module.

Figure 9-9

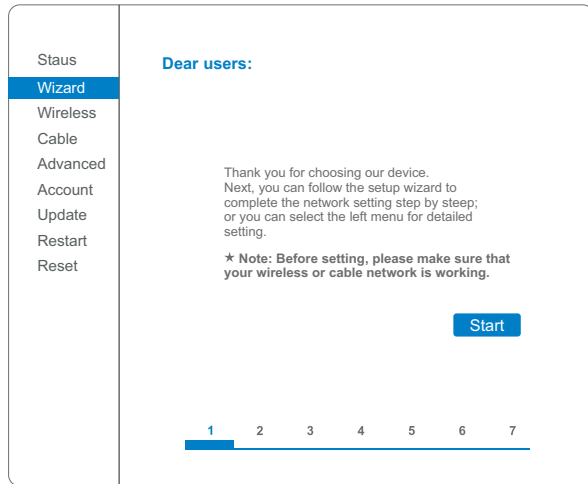

**Setp6:** Select Wireless connection, and click Next.

Figure 9-10

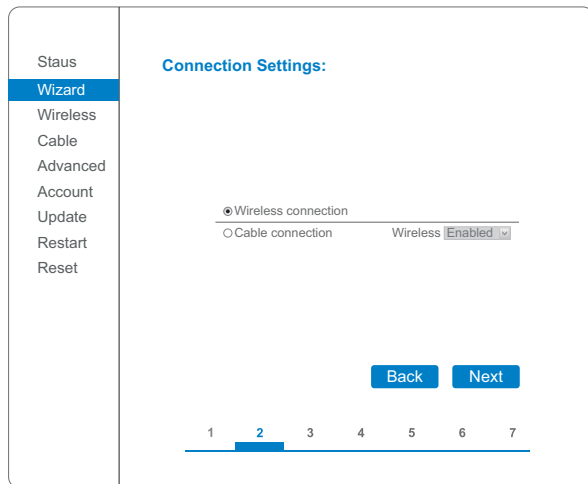

**Note** If the signal strength (RSSI) of your selected internet access point (AP) is lower than 15%, the connection may be unstable, please select other available network or shorten the distance between the device and the router, or reference section 4.6 Figure 4-28.

**Setp7:** Select your personal wireless network. This can be done by refreshing your wireless network or add it manually. See Figure 9-11

Figure 9-11

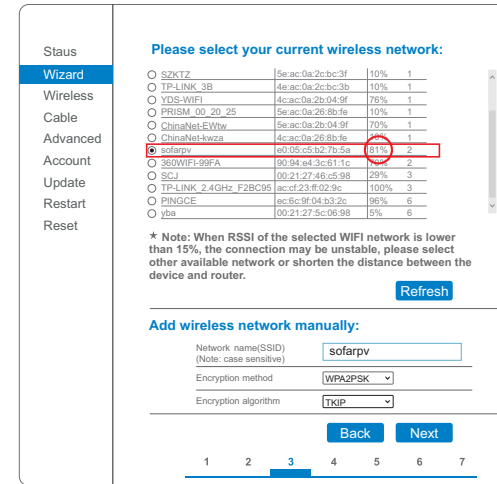

**Note** If you choose to add your wireless network manually, please keep encryption method and encryption algorithm the same as your home router's setup.

**Setp8:** Please enter your personal wireless network password. Then click Next.

Figure 9-12

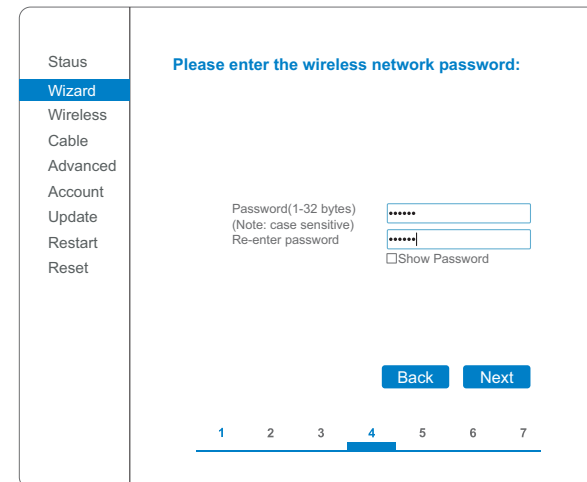

**Setp9:** Select Enable > Next to obtain IP address automatically.

Figure 9-13

|               |  |
|---------------|--|
| Staus         | <p><b>Please fill in the following information:</b></p> <p>Obtain an IP address automatically <input type="text" value="Enable"/></p> <p>IP address <input type="text" value="0.0.0.0"/></p> <p>Subnet mask <input type="text" value="0.0.0.0"/></p> <p>Gateway address <input type="text" value="0.0.0.0"/></p> <p>DNS server address <input type="text"/></p> <p><input type="button" value="Back"/> <input type="button" value="Next"/></p> <p>1 2 3 4 <b>5</b> 6 7</p> |
| <b>Wizard</b> |  |
| Wireless      |  |
| Cable         |  |
| Advanced      |  |
| Account       |  |
| Update        |  |
| Restart       |  |
| Reset         |  |

**Setp10:** Click Next.

Figure 9-14

|               |   |
|---------------|---|
| Staus         | <p><b>Enhance Security</b></p> <p>You can enhance your system security by choosing the following methods</p> <p><b>Hide AP</b> <input type="checkbox"/></p> <p><b>Change the encryption mode for AP</b> <input type="checkbox"/></p> <p><b>Change the user name and password for Web server</b> <input type="checkbox"/></p> <p><input type="button" value="Back"/> <input type="button" value="Next"/></p> <p>1 2 3 4 5 <b>6</b> 7</p> |
| <b>Wizard</b> |   |
| Wireless      |   |
| Cable         |   |
| Advanced      |   |
| Account       |   |
| Update        |   |
| Restart       |   |
| Reset         |   |

**Setp11:** Click OK to wait for setting complete.

Figure 9-15

|               |  |
|---------------|--|
| Staus         | <p><b>Setting complete!</b></p> <p>Click OK, the settings will take effect and the system will restart immediately.</p> <p>If you leave this interface without clicking OK, the settings will be ineffective.</p> <p><input type="button" value="Back"/> <input type="button" value="OK"/></p> <p>1 2 3 4 5 6 <b>7</b></p> |
| <b>Wizard</b> |  |
| Wireless      |  |
| Cable         |  |
| Advanced      |  |
| Account       |  |
| Update        |  |
| Restart       |  |
| Reset         |  |

Figure 9-16

|               |  |
|---------------|--|
| Staus         | <p><b>Setting complete! Please close this page manually!</b></p> <p>Please login our management portal to monitor and manage your PV system.(Please register an account if you do not have one.)</p> <p>More login the configuration interface, please make sure that your computer or smart phone and our device are in the same network segment, and enter the new IP address of the device to access the interface.</p> <p>1 2 3 4 5 6 <b>7</b></p> |
| <b>Wizard</b> |  |
| Wireless      |  |
| Cable         |  |
| Advanced      |  |
| Account       |  |
| Update        |  |
| Restart       |  |
| Reset         |  |

**Setp12:** Setup of wireless network connection priority and connection mode.

Open Control panel > Network and sharing center > Manage wireless networks. Set your home router's access point as default to connect with your personal computer automatically. Make sure it has the highest priority. To the device Wi-Fi module, set its AP as default to connect with your personal computer manually.

Example: make sure "sofarpv" wireless network connection priority is the highest.

Figure 9-17

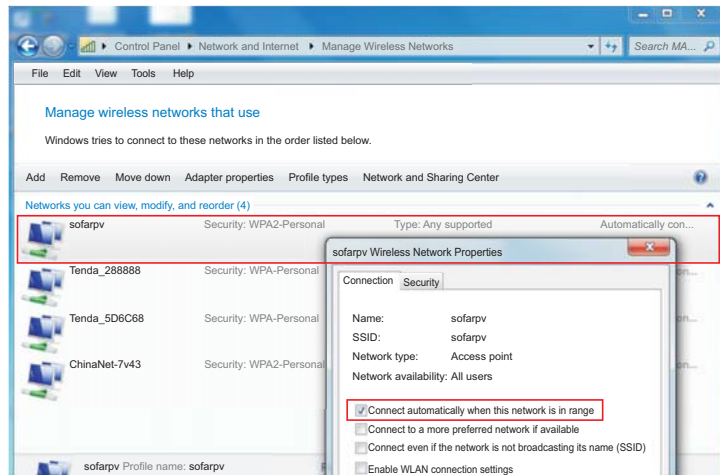

**Setp13:** Connect with your personal wireless network or WLAN.

Figure 9-18



## 9.2 Register on SolarMAN Portal

Launch your browser, open SolarMAN portal website: <http://www.solarmanpv.com/portal/>

**Procedure:**

**Step1:** Click on Register now if you do not have an account.

Figure 9-19



**Step2:** Fill in basic registration information upon request.

Figure 9-20



**Note**

Browsers like internet Explorer 8+, chrome 15+ and Firefox 10+ are recommended.

Setp3: Fill in details to complete the registration.

Figure 9-21

Setp4: If registration is successful, the above page will display. Click OK to return to the homepage of the portal.

Figure 9-22

### 9.3 Log in SolarMAN Portal to manage power station

After successful registration, open the login page of SolarMAN Portal, and input your E-mail and password to access the monitoring system and start monitoring and management of power plants.

Figure 9-22

**Note** In order to make sure your solar system is being well monitored by our SolarMAN monitoring system, please click the Real Time label to see if there is real time data within 15 minutes. If so, your SolarMAN network setup is successful. If not, please re-check the above procedure.

Figure 9-23

| No. | Inverter S/N   | DC Input |            |            | AC Output |            |            | Total Energy(kWh) | Temperature |          |
|-----|----------------|----------|------------|------------|-----------|------------|------------|-------------------|-------------|----------|
|     |                | Channel  | Voltage(V) | Current(A) | Phase     | Voltage(V) | Current(A) |                   |             | Power(W) |
| 1   | SA1ES003E3Q001 | PV1      | 352.2      | 1.2        | L1        | 227.6      | 1.8        | 420               | 717         | 45.0     |
|     |                | PV2      | 0.0        | 0.0        | L2        | 0.0        | 0.0        | 0                 |             |          |

★ Add more inverters on SOFAR SolarMAN monitoring system

Click Setting > Device > Add to enter the 9-digit serial number (SN), and then click OK to complete the setting of adding a new inverter.

Figure 9-24

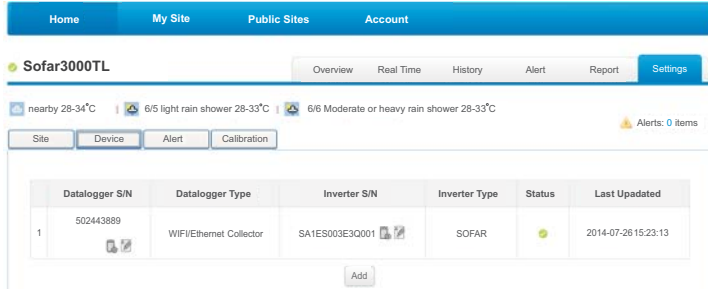
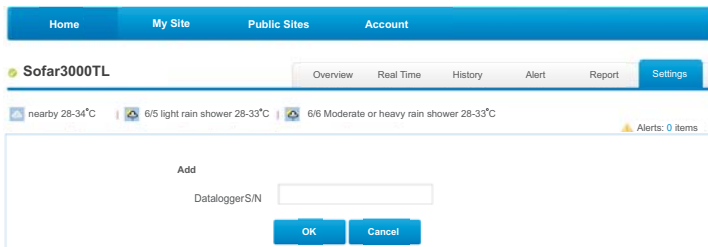

Figure 9-25



★ Alert notification setup

When any abnormal situation happened to the device, an error message would be sent automatically to your designated email account in second.

Please fill in below your personal email account to complete the setup of your alert notification.

Figure 9-26

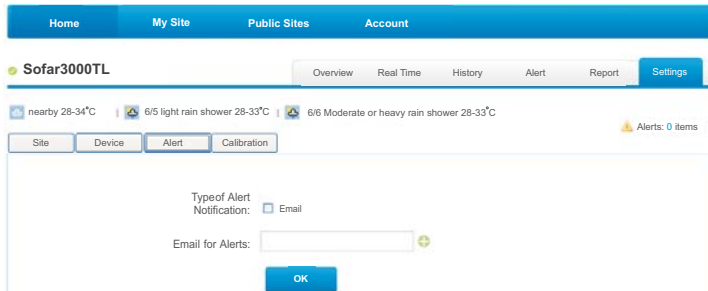

# Quality Assurance

Shenzhen SOFARSOLAR Co., Ltd. offers 5 years product warranty for Sunny Deer series inverters from date of installation. However the warranty period can't exceed 66 months from the date of delivery of the inverter. During the warranty period, Shenzhen SOFARSOLAR Co., Ltd. guarantees normal operation of the inverter. During the warranty period, if the inverter is defective or faulty, please contact your installation contractor or supplier. If the fault is SOFARSOLAR's responsibility, Shenzhen SOFARSOLAR Co., Ltd. will provide service and maintenance free of charge.

## Disclaimer:

- Use of Sunny Deer series inverters for any other purpose than it's intended for;
- Faulty system design or installation;
- Improper operation;
- Wrong protection settings of the inverter;
- Unauthorized modification of the inverter;
- Damage caused by external factors or force majeure (violent or stormy weather, lightning, over-voltage, fire, earthquake, tsunami etc.).