

Energy Storage Inverter

User Manual

(for ME-3000SP)



Contents

1. Equipment Introduction.....	2
2. Equipment Safety Notes.....	2
2.1 Safety Signs.....	2
2.2 Safety Notes.....	3
2.3 Battery Installation and Maintenance Notes.....	4
3. Installation.....	5
3.1 Product Overview.....	5
3.2 Packing List.....	5
3.3 Installation Environment.....	6
3.4 Installation Tools.....	7
3.4 Installation Position.....	9
3.5 Mount ME-3000SP.....	9
4. Electrical Connection.....	11
4.1 Battery Connection.....	12
4.2 CT / RS485 / NTC connection.....	12
4.3 Grid & Load Connection.....	15
5. Indicators and Keys.....	16
6. Operation.....	17
6.1 Double Check.....	17
6.2 First Time Setup.....	17
7. Technical Data.....	20
8. Country Code.....	21
9. Troubleshooting.....	21

1. Equipment Introduction

This product is mainly applied and developed for the adjustable PV generation system and a small power storage system equipped with the most common lead acid batteries or lithium batteries. It can achieve the optimal usability of battery power automatically. ME-3000SP storage inverter can control the off-grid, on-grid and the bi-directional flow of electric power, work under the auto / manual mode and time-of-use (TOU) price mode, automatically switch to the off-grid and on-grid work mode and manage the battery charge / discharge, etc. Also, the inverter has the intelligent on-grid discharge function by setting and can adjust its discharge power according to the change of the load power, avoid the feed of redundant power into the power grid and help the user to make the maximum benefit. This storage inverter can choose DC bus occasion in connection with the PV system and also be used as a pure off-grid inverter if there is no PV system. The equipment is equipped with a LCD display panel and keyboard, high-quality Human Machine Interface and is stable, safe and reliable. The monitoring software has the fault history recording function for later-stage maintenance.

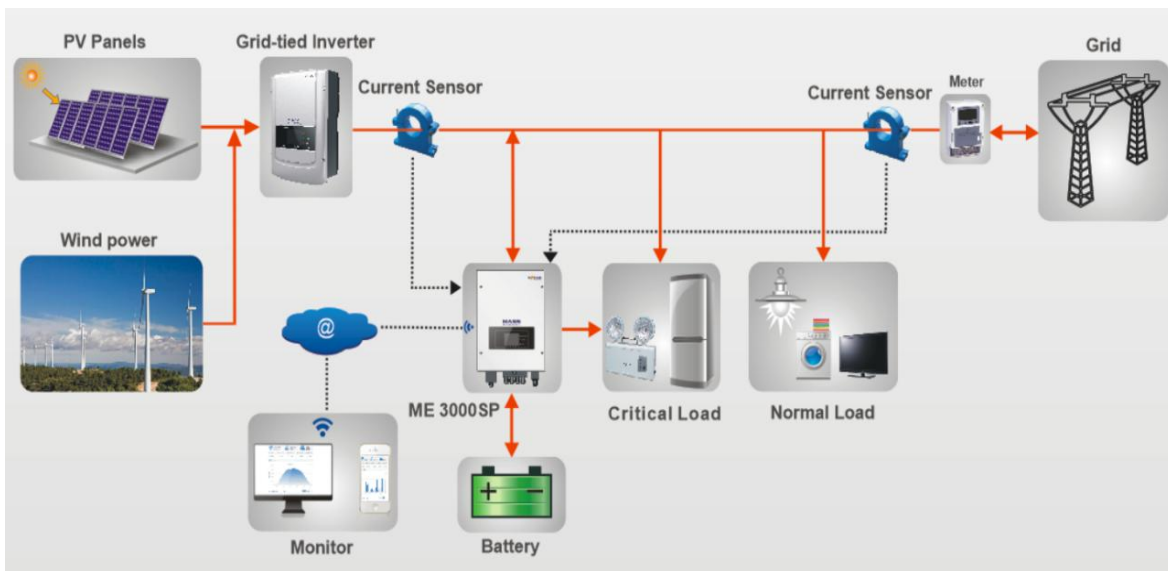







Fig. 1 ME-3000SP Storage System Solution

2. Equipment Safety Notes

Before the inverter is used, please read all instructions, warning signs and this manual. The inverter strictly meets safety rules of design and testing. During the installation, operation and maintenance, operators should abide by safety regulations. Improper operation may cause an electric shock or damage the equipment and properties.

2.1 Safety Signs

 Danger	<p>Danger indicates a hazardous situation which, if not avoided, will result in death or serious injury.</p>
 Warning	<p>Warning indicates a hazardous situation which, if not avoided, could result in death or serious injury.</p>
 Caution	<p>Caution indicates a hazardous situation, if not avoided, could result in minor or moderate injury.</p>
 Attention	<p>Attention indicates there are potential risks. If fail to prevent, may lead to equipment cannot run normally or property damage.</p>
 Note	<p>Note provides tips that are valuable for the optimal operation of the product.</p>

2.2 Safety Notes

- ✧ Electrical installation and maintenance must be carried out by competent electricians according to national connection rules.
- ✧ This inverter must be made only by qualified technical personnel, and only after receiving appropriate approvals, as required by the local authority having jurisdiction.
- ✧ The battery chamber should keep a certain distance with the storage inverter and protected well to prevent from collision.
- ✧ It is forbidden to place explosives and combustibles, e.g. gasoline, kerosene, oil, slab, cotton and rag, around the storage inverter.
- ✧ An electric shock must be avoided and the battery input and AC output of the inverter shall be stopped for at least 5min. before its installation or maintenance.
- ✧ The temperature of some parts of the inverter may exceed 60°C . The inverter shall be cooled down in order to avoid scalding during the maintenance.
- ✧ Children should not go near the inverter.
- ✧ Please do not open the outer cover of the inverter without permission, except for the wire connections. If someone touches or changes its components without permission, he might be injured and even damage the inverter.
- ✧ Static power may damage electronic elements. An appropriate method should be adopted for preventing from such damage; otherwise, the inverter might be damage and the warranty will be invalid.
- ✧ If the Equipment is damaged because it is not operated according to the operation method of the specified manufacturer, the warranty will be invalid.

- ✧ To completely isolate the inverter: firstly shut down the DC switch and then disconnect the battery and the AC terminal.
- ✧ The storage inverter shall be isolated completely before being maintained. The inverter must not be maintained in other modes!
- ✧ It is forbidden to disconnect the battery terminal and AC terminal when the storage inverter is running normally.

2.3 Battery Installation and Maintenance Notes

- ✧ The battery has been charged before being delivered and shall be prevented from short circuit in the transportation and installation process.
- ✧ The battery shall be placed in a well-ventilated space. Do not install the battery in airtight or badly ventilated spaces or equipment. Otherwise, the equipment might crack.
- ✧ Do not place the battery in high temperature situations, direct sunshine or in front of a furnace or fire. Otherwise, the battery might leak and fire or crack.
- ✧ The connection cable shall be as short as possible to avoid too much voltage drop.
- ✧ Before connecting the terminal connecting piece and switching on the battery system, check the total voltage and anode and cathode of the battery system to ensure the correct installation.
- ✧ If you want to store the battery, the battery bank should be disconnected from the charger and load and the environment shall be kept cool, dry and ventilated.

Please be noted that it is not necessary to provide the reservation information with the following exact measures:

- Battery maintenance operators shall have the know-how and technical skill for the maintenance of the battery;
- When the battery is changed, the battery bank of the same model and quantity shall be changed;
- Warning: Do not dispose of scrap batteries with fire. Otherwise, the batteries might explode.
- Warning: Do not dismantle or damage the battery. Its electrolyte might be toxic and damage your skin and eyes.
- Warning: The battery may cause an electric shock or short circuit. Please take the following measures for the battery work:
 - a) Take off your watch, ring or other metal objects.
 - b) Use the tool with insulated handles.
 - c) Wear rubber gloves and shoes.
 - d) Do not put tools and metals above the battery.
 - e) Switch off the charge power supply before the battery terminal is disconnected.
 - f) Check if the battery is connected to the ground. If so unconsciously, disconnect the battery from the ground. Any part that touches the ground battery may suffer an electric shock. Disconnect the battery from the ground during installation and maintenance, so as to reduce the possibility of such a shock (applicable to the equipment and remote power supply without power circuits connected to the ground).

3. Installation

3.1 Product Overview

The inverter is checked strictly and checked before being packed and delivered. It is forbidden to put it upside down position during delivery.

Please check the product package and internal components carefully before installation, e.g. housing, display and DC connection terminals.

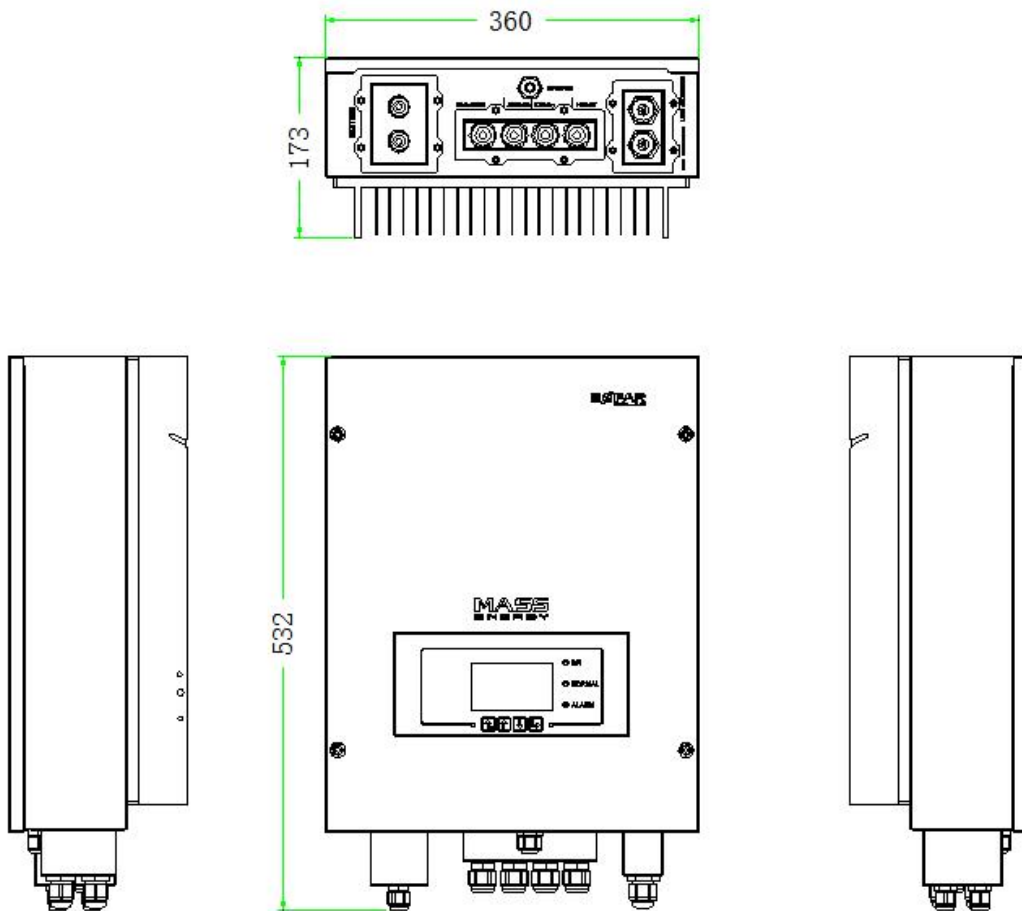

Fig. 2 ME-3000SP Overview

3.2 Packing List

Before installation, please inspect the unit. Be sure that nothing inside the package is damaged. You should have received the following items inside of package:









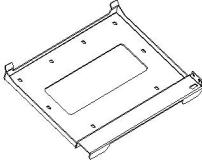

 <p>Mounting Bracket×1</p>	 <p>AC terminal×6</p>	 <p>M5 screw×2</p>	 <p>Battery terminal×2</p>
 <p>M6 flat washer×8</p>	 <p>Expansion Bolts×8</p>	 <p>Terminal cap×4</p>	 <p>CT terminal×2</p>
 <p>Current Transformer× 2</p>	 <p>User Manual×1</p>	 <p>Warranty card×1</p>	 <p>Quality Certificate×1</p>

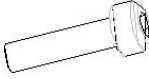
Fig. 3 Accessories of ME-3000SP

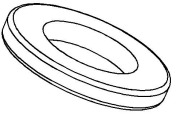
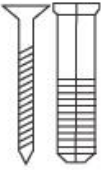
3.3 Installation Environment

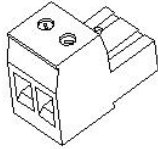
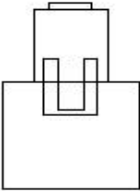
- Clean and tidy indoors, convenient for installation and in a dry position
- Ambient temperature scope: -20C°~45C°
- Relative humidity: 0~95%(non-condensed)
- The storage inverter shall be installed in the place with independent air inlet and outlet channels.
- There is neither inflammable nor explosive around.
- The storage inverter shall be connected to the power grid with an over-voltage of CATIII and CAT II.
- The maximum work altitude is 2000m.
- Please consult our engineers about detailed requirements for installation.

3.4 Installation Tools

The following tools shall be prepared before installation:

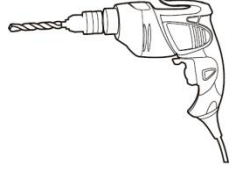
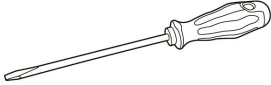
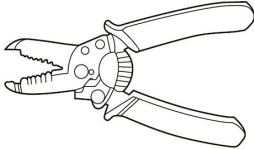
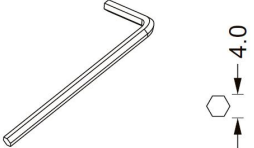
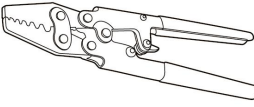
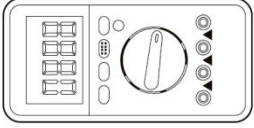
No.	Tool	Model	Function
1		Hammer drill Recommend drill dia.6mm	Used to drill holes on the wall
2		Screwdriver	wiring
3		Wire stripper	Strip wire
4		4mm Allen Wrench	Turn the screw to connect rear panel with inverter
5		Crimping tools	Used to crimp power cables
6		Multi-meter	Used to check grounding

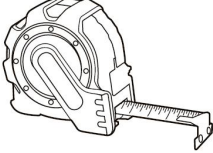
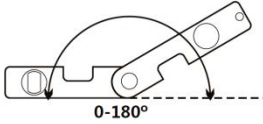
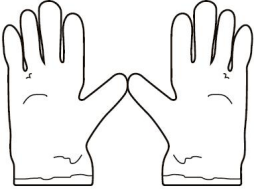
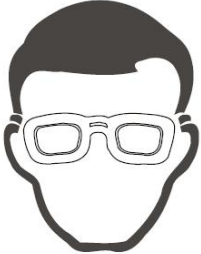
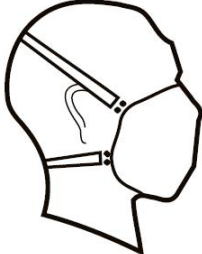
7		Marker pen	Used to mark signs
8		Measuring tape	Used to measure distances
9		Level	Used to ensure that the rear panel is properly installed
10		ESD gloves	Operators wear
11		Safety goggles	Operators wear
12		Anti-dust respirator	Operators wear

3.5 Installation Position

ME-3000SP should be vertically mounted (to ensure fast heat dissipation), please choose a position without direct sunlight / snow accumulation to install ME-3000SP.

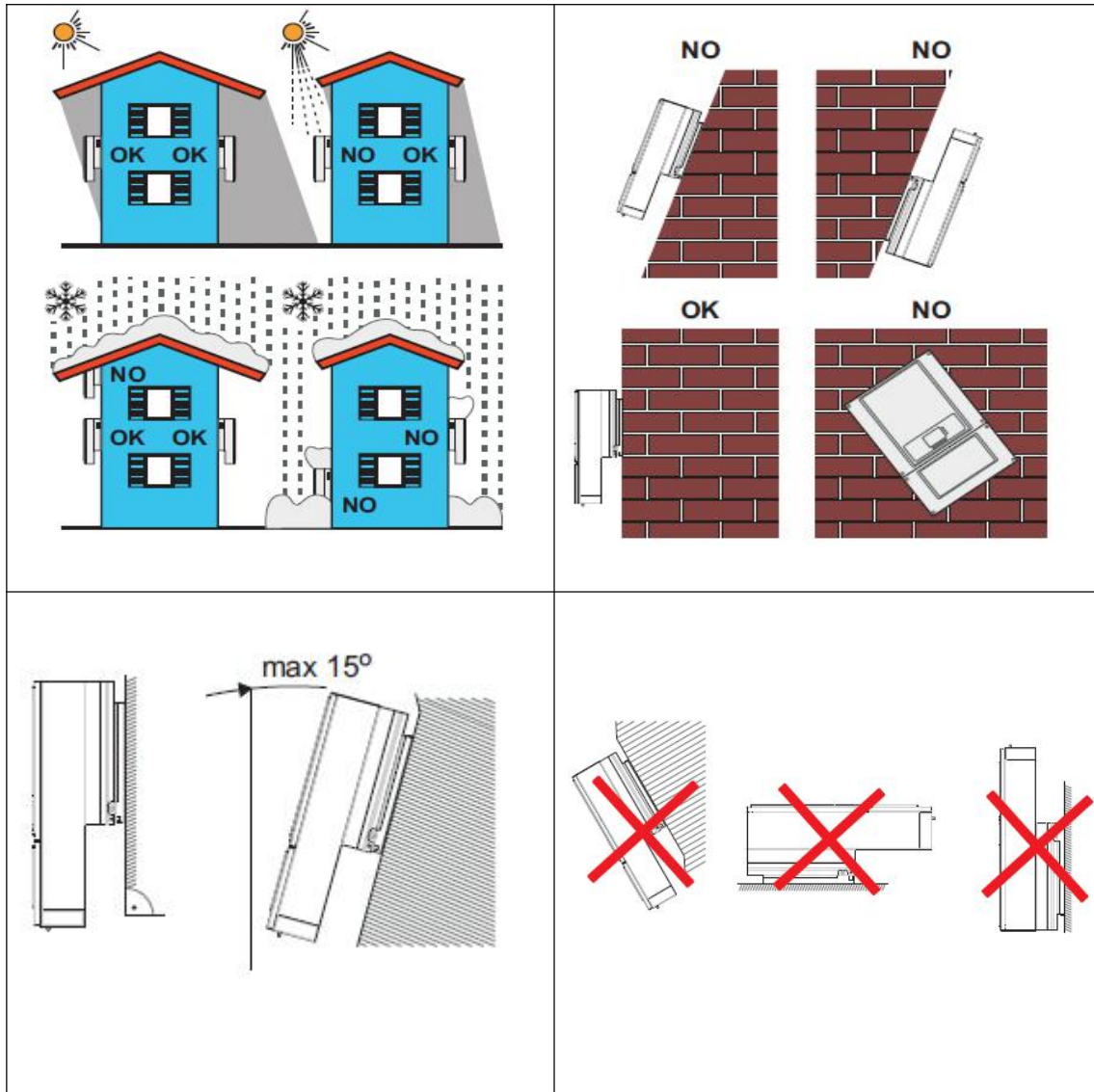

Fig. 4 Installation Position of ME-3000SP

3.6 Mount ME-3000SP

Step 1: Put the mounting bracket properly on the wall, mark these 8 drill holes using a marker pen. Drill 8 holes (drill bit 6mm) on the wall.

Step 2: Insert the expansion screw vertically into the hole, note the insertion depth. (not too shallow or too deep)

Step 3: Fix the mounting bracket on the wall using bolts & flat washers.

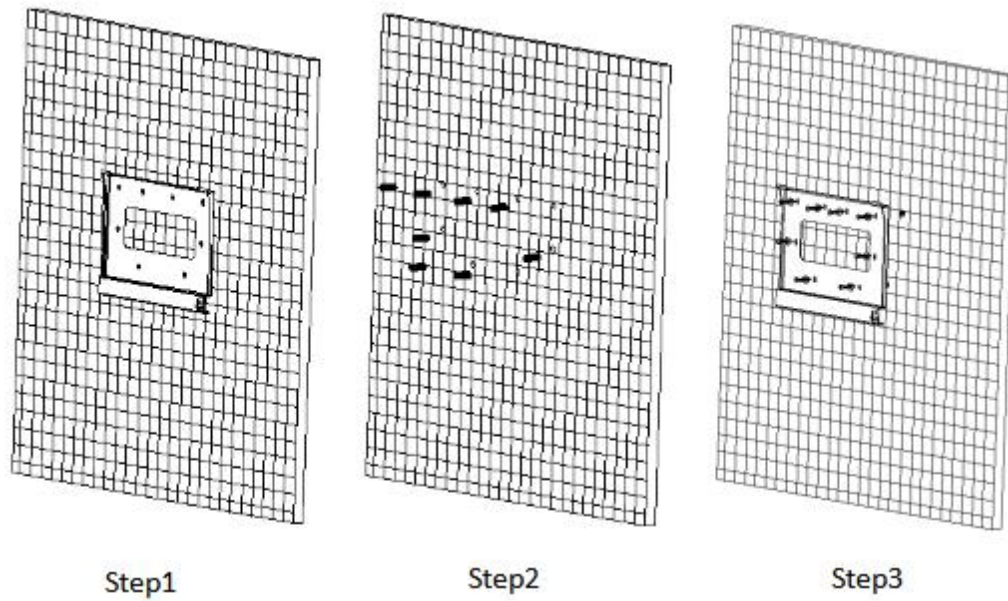

Step 4: Put ME-3000SP on the mounting bracket.

Step 5: Earth ME-3000SP using the grounding hole on the heat sink.

Step 6: OPTIONAL: you can lock ME-3000SP

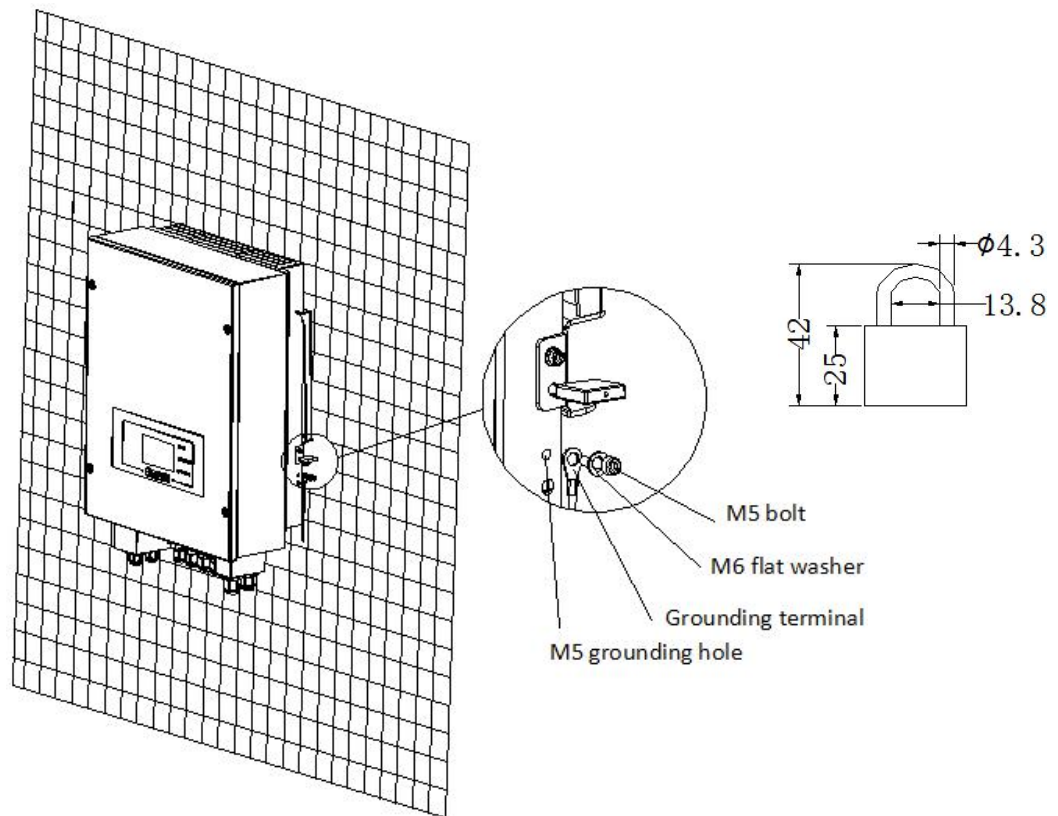

4. Electrical Connection



Warning

- Be aware of electric shock and chemical hazards!
- Before connecting the battery, ensure the cable connectors have the correct polarity. Reversed polarity will damage the inverter!
- Before connecting to battery, please install a separate DC breaker(100A) between inverter and battery. This will ensure the inverter can be securely disconnected during maintenance.
- Before connecting to Grid, please install a separate AC breaker(25A) between inverter and grid.
- It is very important for system safety and efficient operation to use appropriate cable for electrical connection.
 - Battery connection: cable of AWG8 or AWG6.
 - Load connection: cable of AWG12.

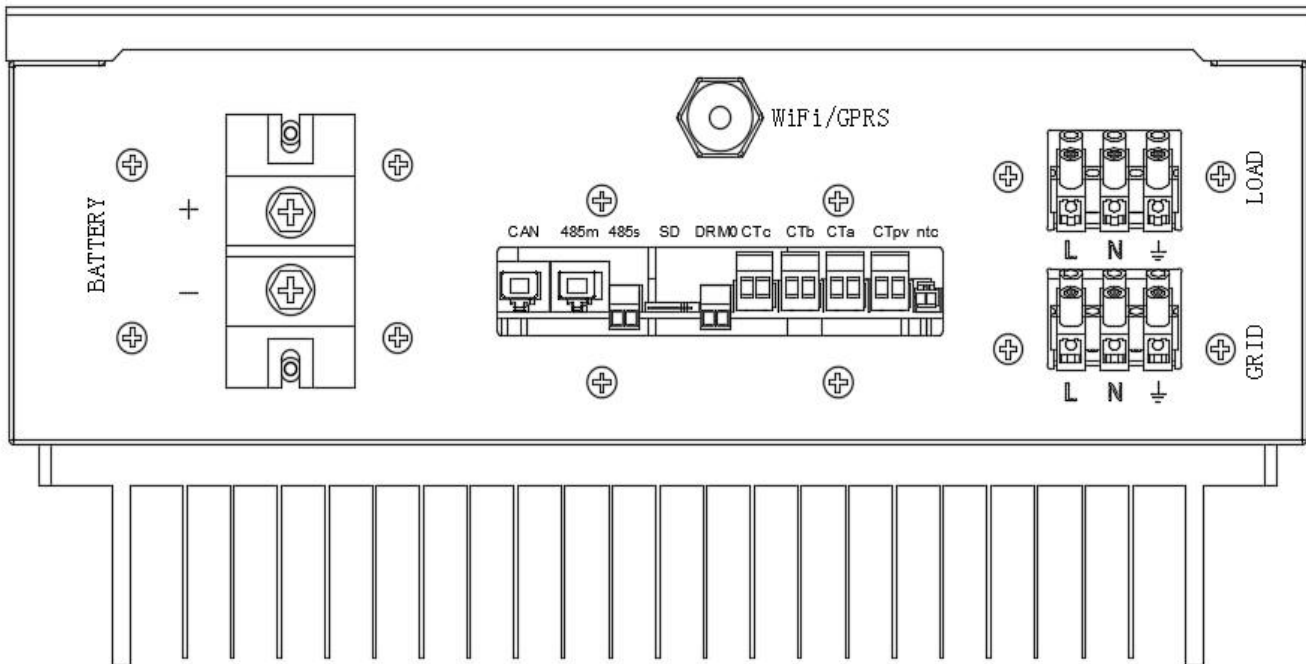

Fig. 5 ME-3000SP Bottom View

4.1 Battery Connection

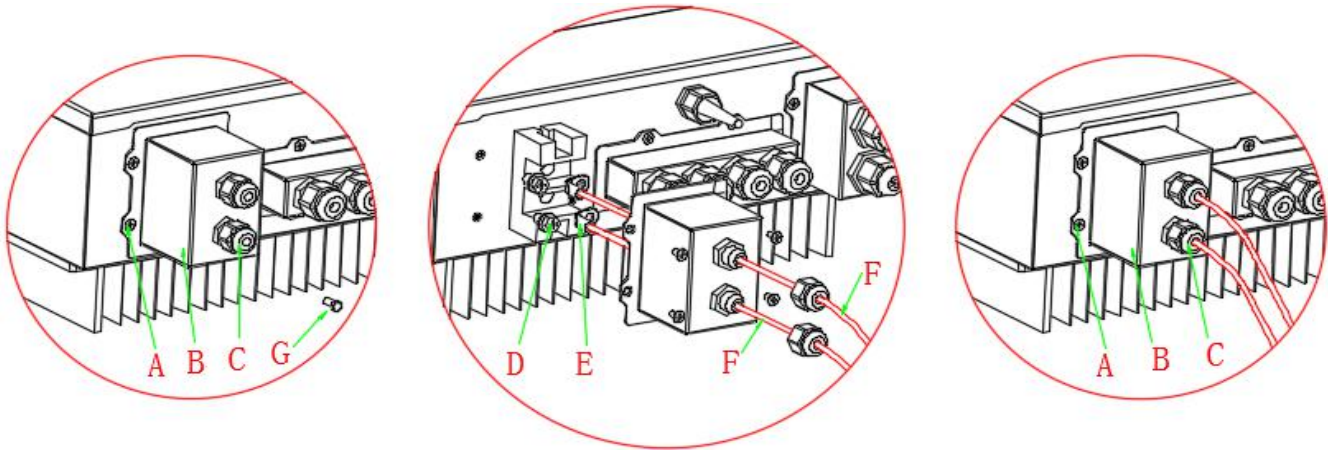

Fig. 6 Battery connection (Test battery wires polarity before connection)

- Step 1: Loosen 4 screws (part A) using a screwdriver (fig. 6)
- Step 2: Remove the waterproof cover (part B), loosen the cable gland (part C), then remove the stopper (part G)
- Step 3: Route the battery wires (part F) through the cable gland, then connect battery wires using OT terminal (part E)
- Step 4: Fasten the waterproof cover using 4 screws.

4.2 CT / RS485 / NTC connection

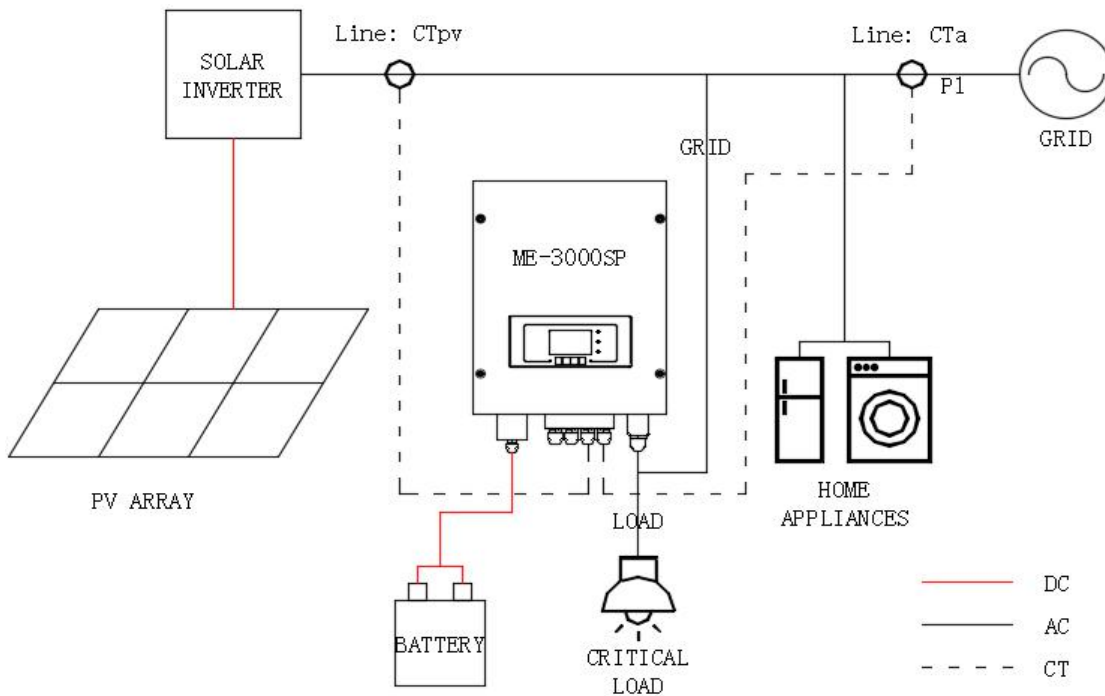

Fig. 7 Schematic Diagram (ME-3000SP: energy storage add-on to existing renewable system)

Step 1: Use network cable & terminal cap to extend the CT wire.

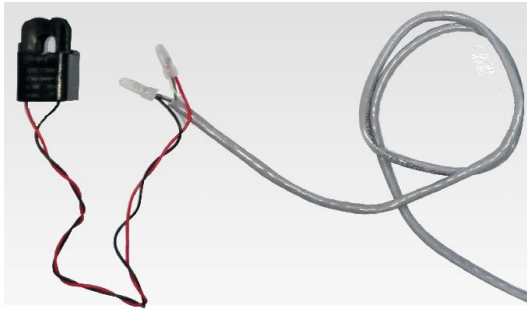

Fig. 8 CT wire extension / Direction of CTa

CT wire	Extension cable (network cable)	ME-3000SP
Red	Orange / white orange / brown / white brown	CT+
Black	Green / white green / blue / white blue	CT-

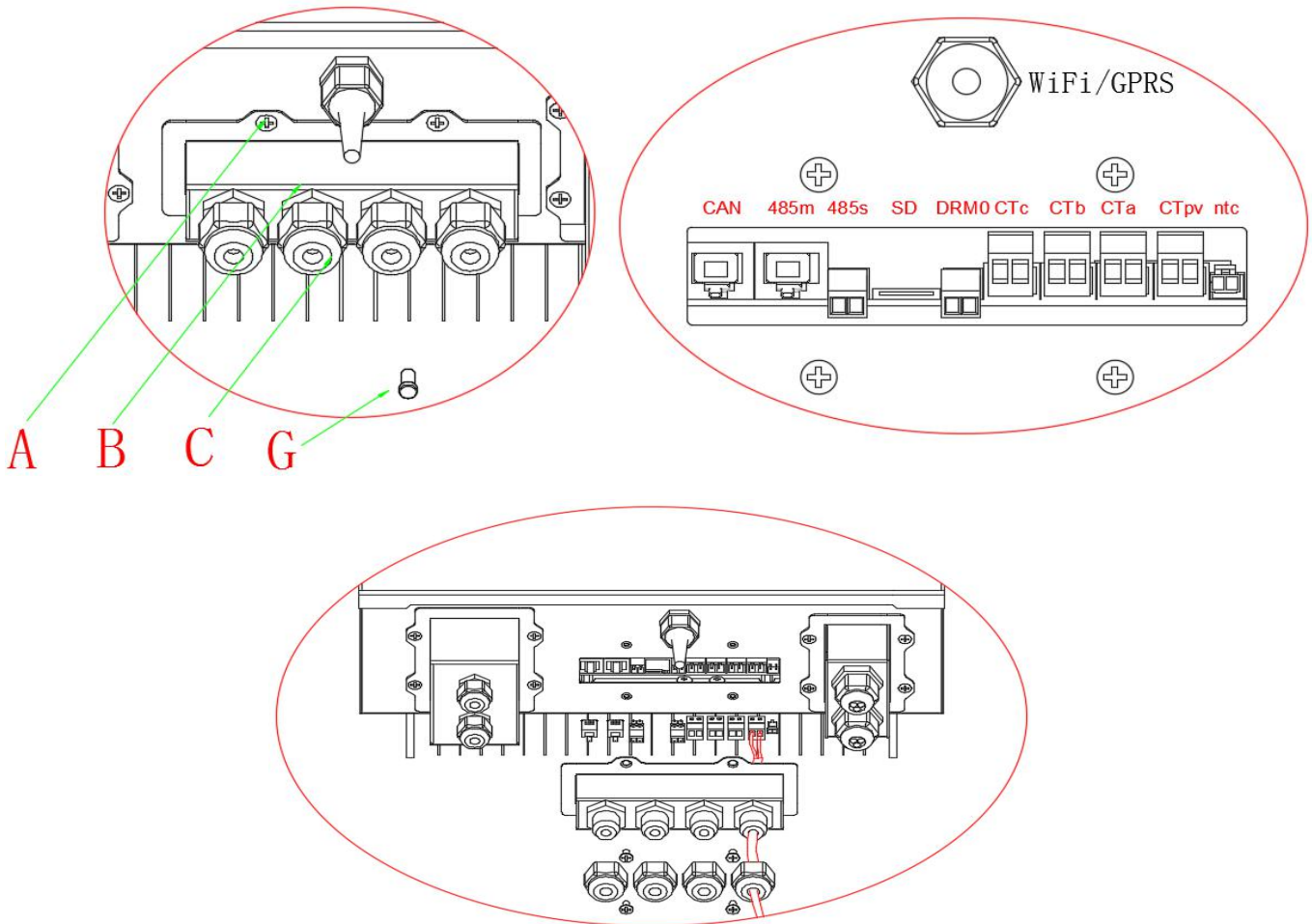

Fig. 9 CT / RS485 / NTC connection

Step 2: Loosen 4 screws (part A) using a screwdriver (fig. 6)

Step 3: Remove the waterproof cover (part B), loosen the cable gland (part C), then remove the stopper (part G)

Step 4: Route CT cable through the cable gland, connect CT cable to CT terminal, then insert CT terminal into corresponding ports. (Form 1)

Step 5: Route RS485 network cable through the cable gland, connect RS485 network cable to RJ45 connector, then insert RJ45 connector into 485M port. (fig. 8)

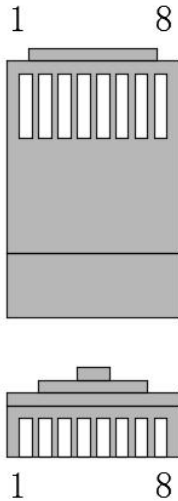

No.	ME-3000SP 485M	PYLONTECH US2000
1		RS485B
2		RS485A
3		GND
4	RS485B	
5	RS485A	
6		GND
7		RS485A
8		RS485B

Form 2 485M connection

Step 6: it's necessary to connect NTC for lead acid batteries:

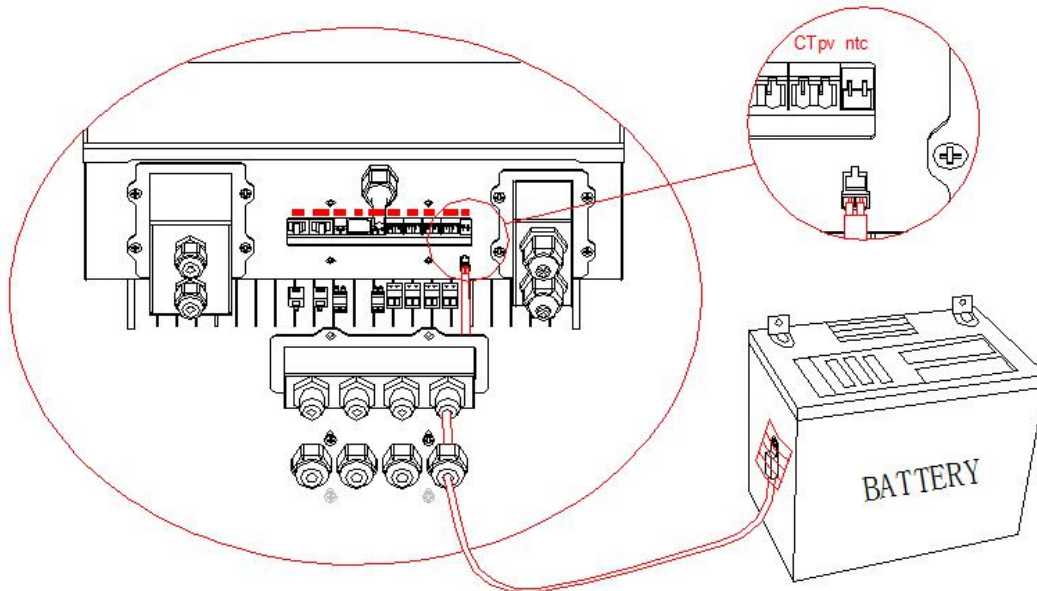

Fig. 10 NTC connection

Step 7: fasten the waterproof cover using 4 screws.

4.3 Grid & Load Connection

Step 1: Loosen 4 screws (part A) using a screwdriver (fig. 9)

Step 2: Remove the waterproof cover (part B), loosen the cable gland (part C), then remove the stopper (part G)

Step 3: Route GRID / LOAD cables through cable glands, then connect GRID / LOAD cables to corresponding terminal blocks.

Step 4: Fasten the waterproof cover using 4 screws.

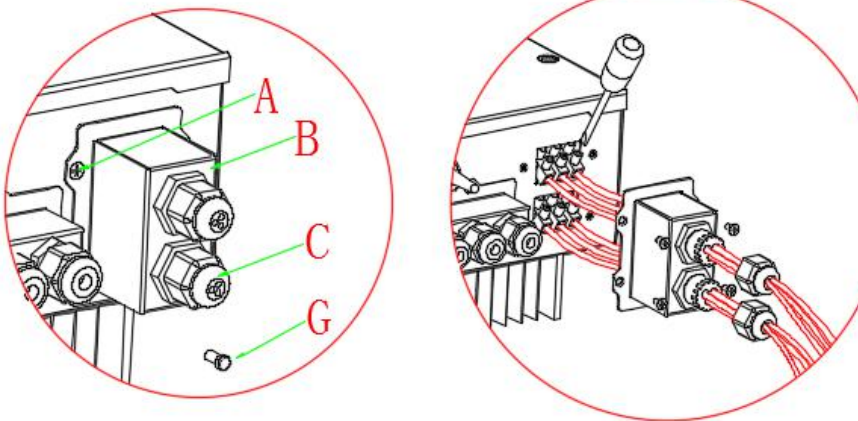
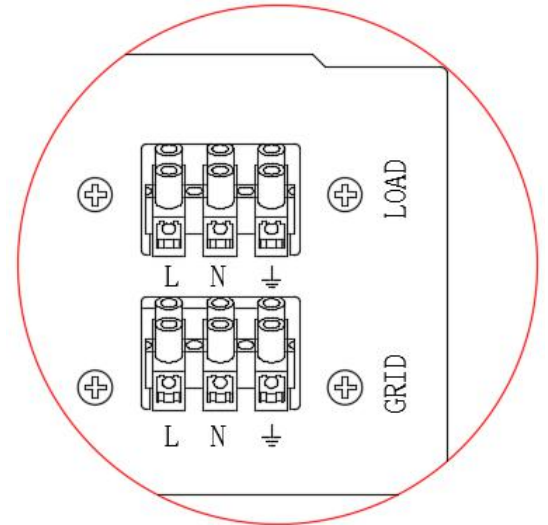

Fig. 11 Grid & Load connection

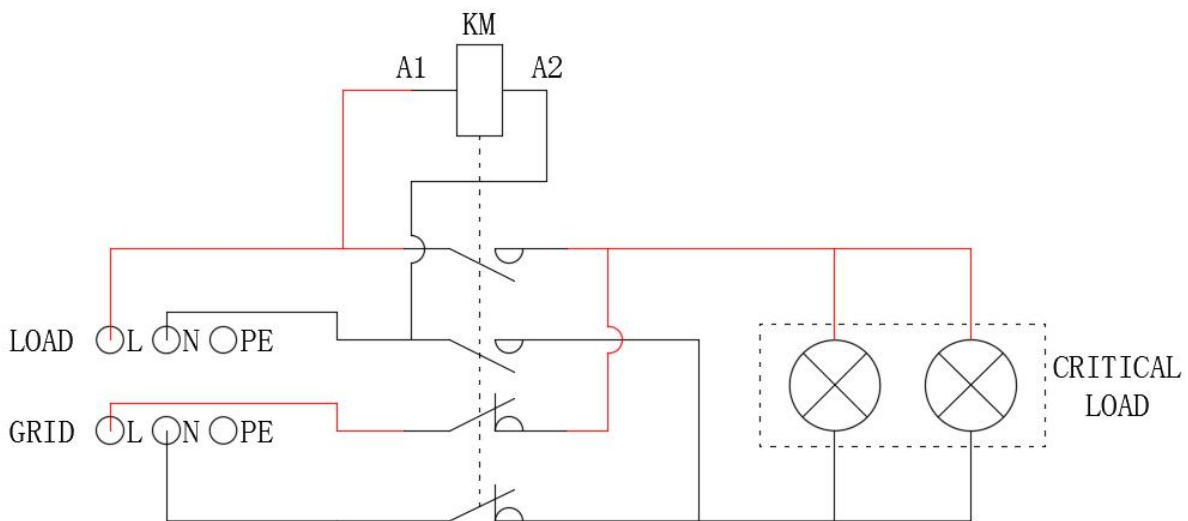
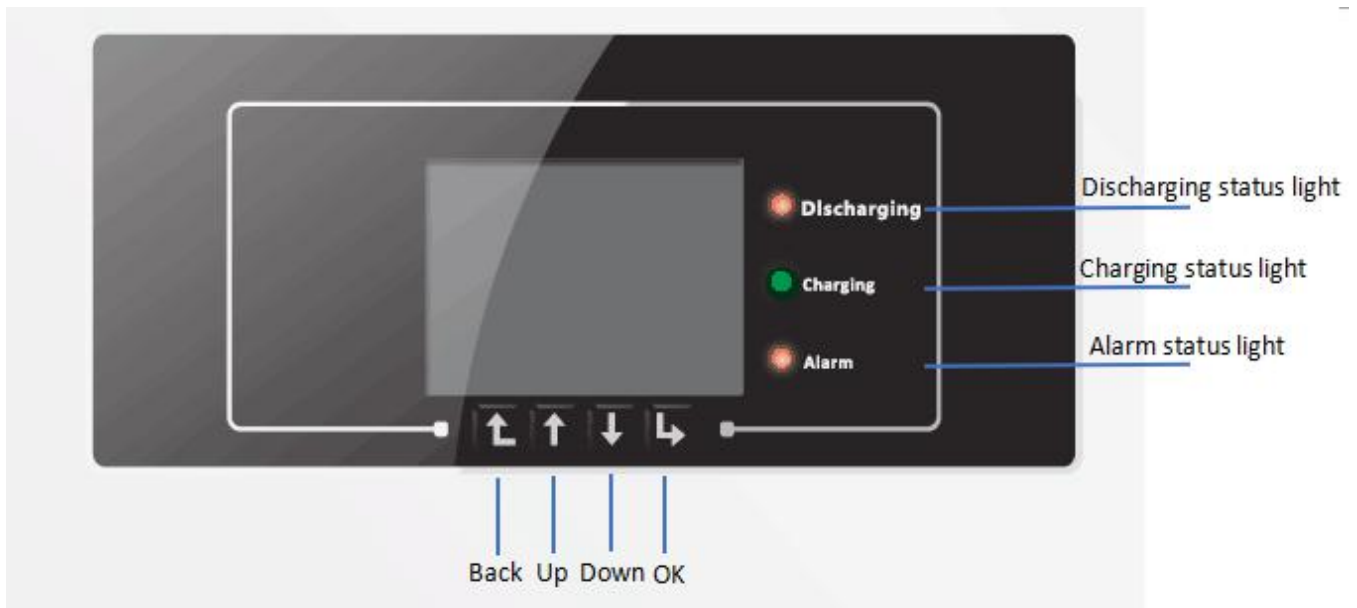

Fig. 12 Connection of critical load (AC contactor: 2 NC, 2 NO)

5. Indicators and Keys



Buttons:

- press “back” to the previous screen or enter into the main interface;
- press “Up” to the last interface or value plus 1;
- press “Down” entry into the next column or value minus 1 ;
- press “OK” to switch to the next digit.

LED lights:

- Charging status Light (Green)
 - When the system is in the state of charge detection, the LED light flashing;
 - When the system is in charging, the LED light is permanently on.
 - When the system is in Fault (fault, or permanet), the LED light goes out.
- Dicharging status Light (Green)
 - When the system is in the state of discharge detection, the LED light flashing;
 - When the system is in discharging, the LED light is permanently on.
 - When the system is in Fault (fault, or permanet), the LED light goes out.
- Alarm light (Red)

When the system is in Fault (fault, or permanet), the LED light is permanently on.

6. Operation

6.1 Double Check

Please double check the following before operation.

1. ME-3000SP is firmly fastened to the mounting bracket on the wall
2. The polarity of battery wires is correct, battery wires are firmly connected
3. DC isolator is correctly connected between battery & ME-3000SP, DC isolator: OFF
4. GRID / LOAD cables are firmly / correctly connected
5. AC circuit breaker is correctly connected between ME3000SP GRID port & GRID, AC circuit breaker: OFF
6. AC contactor is correctly connected (fig. 12)
7. For lithium battery, please ensure that the RS485 communication wire have been connected;
8. For the lead-acid battery, please ensure that the NTC wire has been connected.

6.2 First Time Setup

As the storage inverter power-on, it needs to set following parameters before operating.

1)Set system time
2)Set country
3)Select battery type
4)Set battery capacity
5)Set bat manage mode
6)Set max charge voltage
7)Set max Charge current
8)Set max protect voltage
9)Set min discharge voltage
10)Set max discharge current
11)Set min protect voltage
12)Set discharge depth
13)Set discharge time
14)Set empty discharge voltage
15)Set full charge voltage

1)Setup system time

System time's format is "Year-Month-Day-Hour-Minutes-Second", press "Up&Down" to change the number, press "Enter" to complete the time setting. When the system setting is complete, then it will turn to "country" setting automatically.

2)Setup country

Press "Up & Down" to select country, press "Enter" to complete the country setting, then it will turn to "battery type" setting automatically.

3)Setup battery type

According to you battery, press "Up&Down" to select the battery type, press "Enter" to complete the battery type setting, then it will turn to "battery capacity" setting automatically.

4)Setup battery capacity

According to the capacity of you battery, press "Up&Down" to select the battery capacity, press "Enter" to complete, then it will turn to "bat manage mode" setting automatically.

5)Setup bat manage mode

Press "Up&Down" to select the suitable manage mode for the battery, press "Enter" to complete, then it will turn to "max charge voltage" setting automatically.

6)Setup max charge voltage

According to the datasheet of you battery, press "Up&Down" to input the max charge voltage, press "Enter" to complete the "max charge voltage" setting, then it will turn to "max Charge current" setting automatically.

7)Setup max Charge current

According to the datasheet of you battery, press "Up&Down" to input the max charge current, press "Enter" to complete the "max charge current" setting, then it will turn to "max protect voltage" setting automatically.

8)Setup max protect voltage

According to the datasheet of you battery, press "Up&Down" to input the max protect voltage, press "Enter" to complete the "max protect voltage" setting, then it will turn to "min discharge voltage" setting automatically.

9)Setup min discharge voltage

According to the datasheet of you battery, press "Up&Down" to input the min discharge voltage, press "Enter" to complete the "min discharge voltage" setting, then it will turn to "max discharge current" setting automatically.

10)Setup max discharge current

According to the datasheet of you battery, press "Up&Down" to input the max discharge current, press "Enter" to complete the "max discharge current" setting, then it will turn to "min protect voltage" setting automatically.

11)Setup min protect voltage

According to the datasheet of you battery, press "Up&Down" to input the min protect voltage, press "Enter" to complete the "min protect voltage" setting, then it will turn to "discharge depth" setting automatically.

12)Setup discharge depth

According to the request of the discharge depth, press "Up&Down" to input the discharge depth, press "Enter" to complete the "discharge depth" setting, then it will turn to "discharge time" setting automatically.

13)Setup discharge time

According to the request of discharge time, press "Up&Down" to input the discharge time, press "Enter" to complete the "discharge time" setting, then it will turn to "empty discharge voltage" setting automatically.

14)Setup empty discharge voltage

According to the datasheet of you battery, press "Up&Down" to input the empty discharge voltage, press "Enter" to complete the "empty discharge voltage" setting, then it will turn to "full charge voltage" setting automatically.

15)Setup full charge voltage

According to the datasheet of you battery, press "Up&Down" to input the full charge voltage, press "OK" to complete the "full charge voltage" setting. It will display "Success", the setting of storage inverter's first operating is completed and press "Back" to return main interface. If "Fail" is displayed, the storage inverter should be reset again.

After the completion of the above settings, turn off the storage inverter, then power on the inverter according to the following steps to complete sensor calibration on the grid and PV :

IMPORTANT: PLEASE FOLLOW THE FOLLOWING PROCEDURE:

1. Turn OFF the solar inverter. Make sure there's no power generation in ME-3000SP's phase.
2. Turn ON DC isolator between battery & ME-3000SP
3. Turn ON AC circuit breaker between ME-3000SP GRID port & GRID.
ME-3000SP should start to operate now.
4. Turn ON some home appliances. Make sure power consumption in ME-3000SP's phase is greater than 200W.
You should be able to read the data on the screen.
5. Turn ON the solar inverter. (power generation > 100W)
6. If power generation > power consumption, battery is not full. ME-3000SP will charge the battery.
7. If power generation < power consumption, battery is not flat. ME-3000SP will discharge the battery.

Every time you change the CT connection, you need to repeat the procedure above.

7. Technical Data

Technical Data		ME 3000SP
BATTERY PARAMETERS		
Battery Type	Lead-acid/Lithium-ion	
Nominal battery voltage	48V	
Battery voltage range	40-60V	
Recommended battery capacity	200Ah (100~500Ah optional)	
Recommended Storage capacity	9.6kWh	
Max.Charging Current	60A	
Charging Current Range	0-60A(Programmable)	
Charging curve	3-stage adaptive with maintenance	
Max.Discharging Current	60A	
Electronic protection	OCP OTP OVP	
Short circuit protection	Fuse (100A)	
Discharge times (Hour)	Po=1kVA 9.6h	
	Po=3kVA 3.2h	
Depth of discharge	Lithium : 0~80%DOD adjustable	
	Lead-acid:0~50%DOD adjustable	
AC PARAMETERS		
Max.Output Power	3kVA	
Rated Input/Output Voltage	230V	
Max.Input/Output Current	13A	
AC Input/Voltage Range	180V-270V	
Grid Frequency Range	44~55Hz / 54~66Hz	
THD	<3%	
Power Factor	1(Adjustable +/-0.8)	
Connection phase	single	
Current(inrush)	0.8A/1us	
Maximum output fault current	100A/1us	
Maximum output overcurrent protection	13A	
SYSTEM PARAMETERS		
Max.Charging Efficiency	94.5%	
Max.Discharging Efficiency	94%	
Stanby Losses	<5W	
Topology	High Frequency Isolated Transformer	
Degree Of Protection	IP65	
Safety Protection	Anti islanding, RCMU, Ground Fault Monitoring	
Certification	A S4777, VDE0126-1-1, G83/2, C10/11, RD1699, UTEC15-712-1, EN50438, VDE-AR-N4105	
Communication	WiFi ,R S485,CAN2.0	
ENVIRONMENTAL		
Ambient temperature range	-25°C...+60°C (Above 45°Derating)	
Allowable Relative Humidity Range	0... 95%, No Condensing	
Max.Operating Altitude	2000m	
Current Sensor Connection	external	
GENERAL DATA		
Noise	<25dB	
Weight	16kg	
Cooling	Natural	
Dimension(W*H*D)	532*360*173mm	
Display	LCD display	
Warranty	5 Years (Optional: extension to 10 years)	
Emergency Power Supply		
EPS rated power	3000VA	
EPS rated voltage, Frequency	230V,50/60Hz	
EPS rated current	13A	
EPS peak power	1.5*Prated, 10s	
Total harmonic distortion	<3%	
Switich time	<3s	

8. Country Code

CODE	Country	CODE	Country
00	Germany4105	13	Germany_BDEW
01	CEI021_INT	14	Germany_0126
02	Australia	15	Italy_CEI0_16
03	SpainRD1699	16	UK_G83
04	Turkey	17	Greece_island
05	Denmark	18	EU_EN50438
06	GreeceContinent	19	EU_EN61727
07	Netherland	20	Customer_VDE0126
08	Belgium	21	Korea
09	UK_G59	22	Sweden
10	China	23	Europe general
11	France	24	CEI021_EXT
12	Poland	25	Cyprus

9. Troubleshooting

Code	Name	description	solution
ID01	GridOVP	The power grid voltage is too high	<p>If the alarm occurs occasionally, the possible cause is that the electric grid is abnormal occasionally. SOFAR inverter automatically returns to normal operating status when the electric grid's back to normal.</p> <p>If the alarm occurs frequently, check whether the grid voltage/frequency is within the acceptable range. If no, contact SOFAR technical support. If yes, check the AC circuit breaker and AC wiring of the SOFAR inverter.</p> <p>If the grid voltage/frequency is within the acceptable range an AC wiring is correct, while the alarm occurs repeatedly, contact SOFAR technical support to change the grid over-voltage, under-voltage, over-frequency, under-frequency protection points after obtaining approval from the local electrical grid operator.</p>
ID02	GridUVP	The power grid voltage is too low	
ID03	GridOFF	The power grid frequency is too high	
ID04	GridUFP	The power grid frequency is too low	

ID05	BatOVP	The battery voltage is too high	<p>If the alarm occurs occasionally, the possible cause is during the process of charging.</p> <p>If the alarm occurs occasionally, check whether the over voltage setting of the battery consistent with the parameter of battery manufacturer and contact SOFAR technical support.</p>	
ID09	HW_LLCCBus_OVP	LLCCBus voltage is too high, and has happen hardware protection	<p>ID09- ID26 are internal faults of SOFAR storage inverter, turn OFF the "DC switch", wait for 5 minutes, then turn ON the "DC switch" and turn ON the "AC switch". Check whether the fault is rectified. If no, please contact SOFAR technical support.</p>	
ID10	HW_Boost_OVP	Boost voltage is too high, and has happen hardware protection		
ID11	HwBuckBoostOCP	BuckBoost current is too high, and has happen hardware protection		
ID12	HwBatOCP	The battery current is too high, and has happen hardware protection		
ID15	HwAcOCP	The grid current is too high, and has happen hardware protection		
ID17	HwADFaultIGrid	The grid current sampling error		
ID18	HwADFaultDCI	The DCI sampling error		
ID19	HwADFaultVGrid	The grid voltage sampling error		
ID21	MChip_Fault	The master chip fault		
ID22	HwAuxPowerFault	The auxiliary voltage error		
ID25	LLCCBusOVP	LLCCBus voltage is too high		
ID26	SwBusOVP	Bus voltage is too high, and has happen software protection		
ID27	BatOCP	Battery current is too high		<p>If the fault occurs frequently, please contact SOFAR technical support.</p>
ID28	DciOCP	The Dci is too high		<p>ID28-ID55 are internal faults of SOFAR storage inverter, turn OFF the "DC switch", wait for 5 minutes, then turn ON the "DC switch" and turn ON the "AC switch". Check whether the fault is rectified. If no, please contact SOFAR technical support.</p>
ID29	SwOCPInstant	The grid current is too high		
ID30	BuckOCP	Buck current is too high		

ID31	AcRmsOCP	The output current is too high	
ID49	ConsistentFault_VGrid	The grid voltage sampling value between the master DSP and slave DSP is not consistent	
ID50	ConsistentFault_FGrid	The grid frequency sampling value between the master DSP and slave DSP is not consistent	
ID51	ConsistentFault_DCI	The Dci sampling value between the master DSP and slave DSP is not consistent	
ID53	SpiCommLose	SPI communication is fault	
ID54	SciCommLose	SCI communication is fault	
ID55	RecoverRelayFail	The relays fault	
ID57	OverTempFault_BAT	THE battery temp is too high	
ID58	OverTempFault_HeatSink	The temperature of heatsink is too high	
ID59	OverTempFault_Env	The environment temp is too high	
ID65	unrecoverHwAcOCP	The grid current is too high,and has cause unrecoverable hardware fault	ID65-ID77 are internal faults of SOFAR storage inverter, turn OFF the “DC switch”, wait for 5 minutes, then turn ON the “DC switch” and turn ON the “AC switch”. Check whether the fault is rectified. If no, please contact SOFAE technical support.
ID66	unrecoverBusOVP	The bus voltage is too high,and has cause unrecoverable fault	
ID70	unrecoverOCPIstant	The grid current is too high,and has cause unrecoverable fault	
ID75	unrecoverEEPROM_W	The EEPROM is unrecoverable	
ID76	unrecoverEEPROM_R	The EEPROM is unrecoverable	
ID77	unrecoverRelayFail	Relay has happen permanent fault	

ID94	Software version is not consistent		Contact SOFAR technical support to upgrade software.
ID95	CommEEPROMFault	The Communication board EEPROM is fault	ID95-ID96 are internal faults of SOFAR storage inverter, turn OFF the "DC switch", wait for 5 minutes, then turn ON the "DC switch" and turn ON the "AC switch". Check whether the fault is rectified. If no, please contact SOFAE technical support.
ID96	RTCFault	RTC clock chip is fault	
ID97	InValidCountry	Invalid Country	Check the country setting according to country ID
ID98	SDfault	The SD card is fault	Please replace the SD card.
ID100	BatOCD	Battery over current discharging protect	ID100-ID103 are battery fault. If this fault occurs occasionally, wait few minutes to see whether the fault is rectified. If this fault occurs frequently, please contact SOFAR technical support.
ID101	BatSCD	Discharging short circuit protect	
ID102	BatOV	Battery high voltage protect	
ID103	BatUV	Battery low voltage protect	
ID104	BatOTD	Battery discharging high temperature protect	Battery fault. Check whether the air condition around the equipment is good. Or set the "max discharging&charging current" a little lower to check whether the fault is rectified. If the fault occurs frequently, please contact SOFAR technical support.
ID105	BatOTC	Battery charging high temperature protect	
ID106	BatUTD	Battery discharging Low temperature protect	Id106-id107 are battery fault. Increase the temperature of the battery. If the fault occurs frequently, please contact SOFAR technical support.
ID107	BatUTC	Battery charging Low temperature protect	