



## Energy Storage Inverter

# User Manual

(ME 3000SP)



2017-05-12

V1.5



# Contents

1.	ME3000SP Introduction.....	5
2.	Safety Notes.....	6
2.1	Safety Notes.....	6
2.2	Battery Installation and Maintenance Notes.....	6
3.	Installation.....	8
3.1	Product Overview.....	8
3.2	Packing List.....	9
3.3	Installation Environment.....	9
3.4	Installation Tools.....	10
3.5	Installation Position.....	11
3.6	Mount ME3000SP.....	11
4.	Electrical Connection.....	13
4.1	Battery Connection.....	14
4.2	CT / RS485 / NTC connection.....	14
4.3	Grid Connection.....	17
4.4	Critical Load Connection (EPS function).....	18
5.	Indicator lights and buttons.....	19
5.1	Buttons:.....	19
5.2	Indicator lights:.....	19
5.3	Status of ME3000SP.....	20
6.	Operation.....	21
6.1	Double Check.....	21
6.2	First Time Setup (important!).....	21
6.3	Commissioning.....	24
6.4	Main Menu.....	25



6.4.1	Parameter setting: .....	25
6.4.2	Event List.....	33
6.4.3	System information interface .....	33
6.4.4	Software upgrade .....	34
6.4.5	Energy Statistics : .....	35
7.	Technical Data.....	36
8.	Troubleshooting.....	37

## 1. ME3000SP Introduction

ME3000SP is an AC coupled bi-directional battery inverter. The customer can purchase batteries & ME3000SP as an energy storage add-on to his/her existing renewable energy system. It can help to achieve optimal usage of renewable energy. ME 3000SP can control the bi-directional flow of electric power, work under auto / manual & time-of-use (TOU) modes, charge / discharge the battery as per customer's setting.

In auto mode, ME3000SP will store surplus renewable energy into the battery & discharge battery to supply power to local load when renewable energy is not enough. ME3000SP is equipped with an LCD display and 4 buttons, friendly human machine interaction system. More importantly ME3000SP is stable, safe, and reliable.

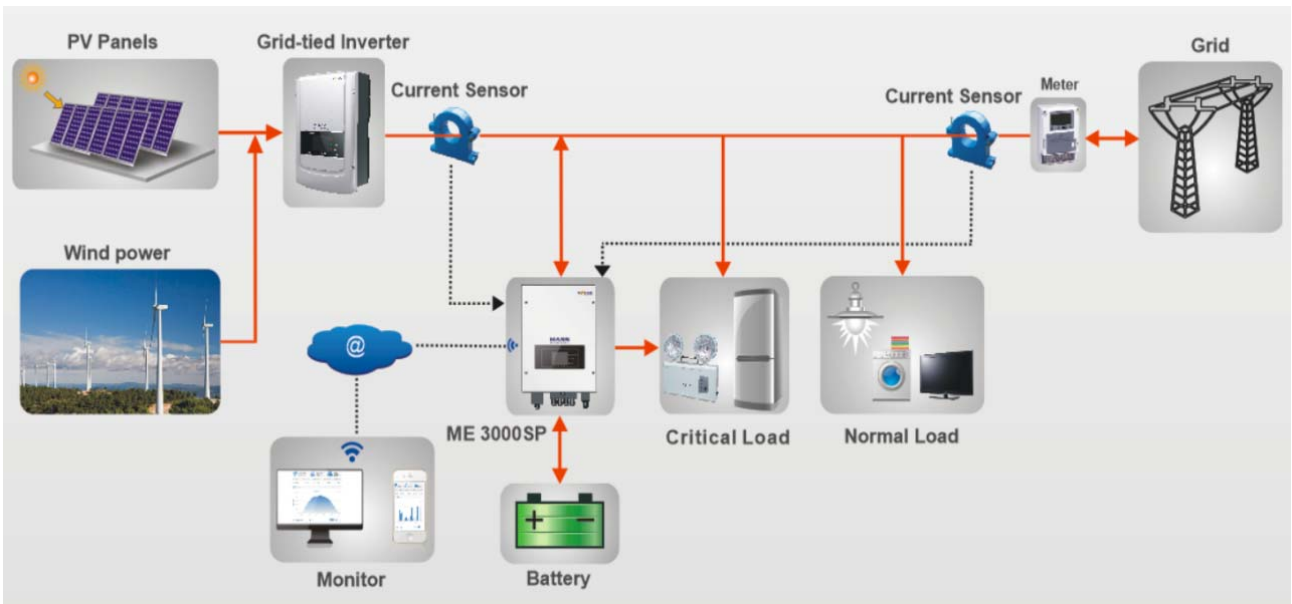

Fig. 1 ME3000SP schematic diagram

## 2. Safety Notes

Before installation, please make sure you read & understand this manual. ME3000SP strictly meets safety rules of design and testing. During the installation, operation and maintenance, operators should abide by local safety regulations. Improper operation may cause an electric shock or damage the equipment and properties.

### 2.1 Safety Notes

- ✧ Electrical installation and maintenance must be carried out by competent electricians according to local regulations.
- ✧ ME3000SP must only be installed by qualified electrician, and only those who have appropriate accreditation, as required by local authority.
- ✧ Do NOT put explosives or flammable materials, e.g. gasoline, kerosene, oil, wood slab, cotton or rag close to batteries / ME3000SP.
- ✧ Disconnect DC (battery) & AC (grid & load) first, then wait at least 5 minutes (discharge capacitors) before maintenance to prevent electric shock.
- ✧ ME3000SP shall be disconnected completely (DC & AC) while being maintained.
- ✧ ME3000SP can be very hot while working. Switch off ME3000SP & wait ME3000SP to cool down before maintenance.
- ✧ Keep children away from batteries & ME3000SP.
- ✧ It's not allowed to open the front cover of ME3000SP. This will void the product warranty.
- ✧ ME3000SP damaged by improper installation/operation will not be covered by the product warranty.

### 2.2 Battery Installation and Maintenance Notes

- ✧ The battery has been charged before being delivered and shall be prevented from short circuit during transportation and installation.
- ✧ The battery shall be placed in a well-ventilated place. Do not put the battery in an airtight or badly ventilated place or cabinet. This can be very harmful to battery performance & cycle life.

- ✧ Keep the battery away from direct sunshine. Don't put battery close to a furnace or fire to avoid battery leak/explode.
- ✧ The current capacity of power cables (from battery to inverter) should be at least 70A. Use short power cables to avoid high voltage drop & power loss.
- ✧ Use a multimeter to check the battery voltage & polarity before switching on the batteries. Make sure connections are correct according to this manual.
- ✧ If you want to store the batteries without using them, they should be disconnected from ME3000SP, and kept in a cool, dry, and ventilated environment.
- ✧ Battery maintenance operators shall have the knowledge and technical skill for battery maintenance;
- ✧ All batteries connected in parallel should be of the same model, and have same firmware version. This is a design issue needs to be considered by designer/installer, particularly when replacing batteries or modifying an existing energy storage system.
- ✧ Warning: Do not disassemble or damage the battery. Its electrolyte can be toxic and damage your skin and eyes.
- ✧ Warning: follow the following rules during battery installation/maintenance.
  - a) Take off your watch, ring, and other metal objects.
  - b) Only use tools with insulated handles.
  - c) Wear rubber gloves and shoes.
  - d) Do not put tools or metals above the battery.
  - e) Switch off ME3000SP & batteries before connecting / disconnecting battery terminals.
  - f) Battery positive / negative poles should be isolated from ground.

### 3. Installation

#### 3.1 Product Overview

ME3000SP is 100% strictly inspected before package and delivery. It is forbidden to put ME3000SP upside down during delivery.

Please check the product package and fittings carefully before installation.

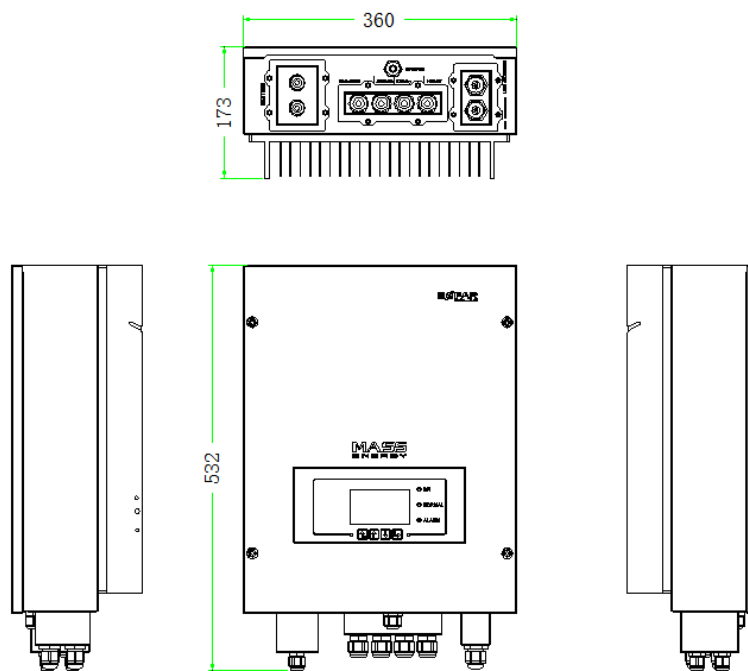

Fig. 2 ME3000SP Overview



### 3.2 Packing List

Inspect the package and fittings carefully before installation. You should have the following fittings:









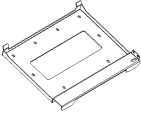

 Mounting Bracket × 1	 AC terminal × 6	 M5 screw × 2	 Battery terminal × 2
 M6 flat washer × 8	 Expansion Bolts × 8	 Terminal cap × 4	 CT terminal × 2
 Current Transformer × 2	 User Manual × 1	 Warranty card × 1	 Quality Certificate × 1
 160 ± 20 Communication cable × 1			

Fig. 3 Accessories of ME3000SP

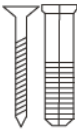

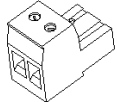
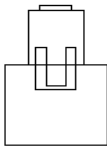

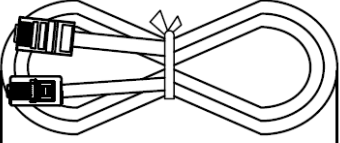

### 3.3 Installation Environment

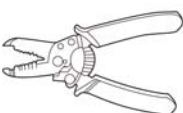

- Dry, clean and tidy, convenient for installation
- Ambient temperature range: -25C ~ 60C
- Relative humidity: 0 ~ 100% (non-condensed)
- ME3000SP shall be installed in a well-ventilated place.
- No flammable or explosive materials close to ME3000SP.

- ME3000SP shall be connected to the electrical grid with an overvoltage category III or category II.
- Maximum altitude: 2000m.

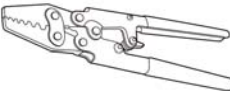
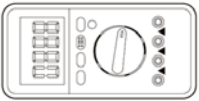
### 3.4 Installation Tools

The following tools shall be prepared before installation:

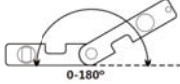
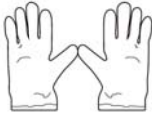
No.	Tool	Model	Function
1		Hammer drill Recommend drill dia.6mm	Used to drill holes on the wall
2		Screwdriver	wiring
3		Wire stripper	Strip wire
4		4mm Allen Key	Turn the screw to connect rear panel with inverter
5		Crimping tools	Used to crimp power cables
6		Multi-meter	Used to check grounding
7		Marker pen	Used to mark signs
8		Measuring tape	Used to measure distances

9		Level	Used to ensure that the rear panel is properly installed
10		ESD gloves	Operators wear
11		Safety goggles	Operators wear
12		Anti-dust respirator	Operators wear

### 3.5 Installation Position

ME3000SP should be vertically mounted (to ensure fast heat dissipation), please choose a position without direct sunlight / snow accumulation to install ME3000SP.

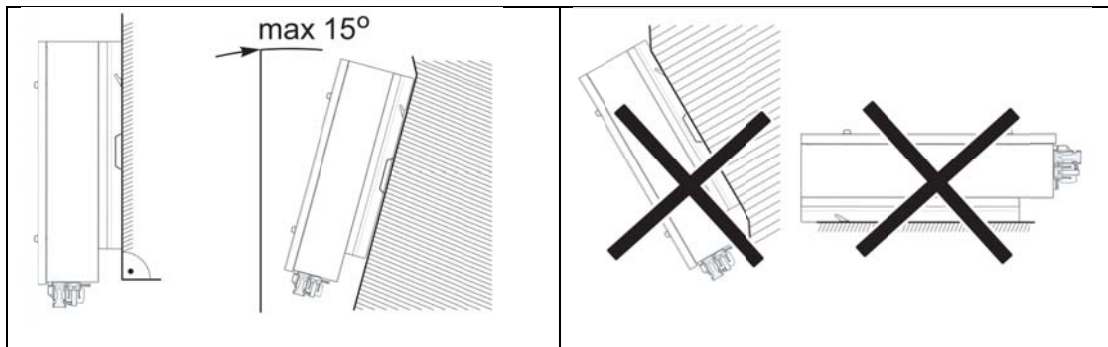

Fig. 4 Installation Position of ME3000SP

### 3.6 Mount ME3000SP

Step 1: Put the mounting bracket properly on the wall, mark these 8 drill holes using a marker pen. Drill 8 holes (drill bit 6mm) on the wall.

Step 2: Insert the expansion screw vertically into the hole, note the insertion depth. (not too shallow or too deep)

Step 3: Fix the mounting bracket on the wall using bolts & flat washers.

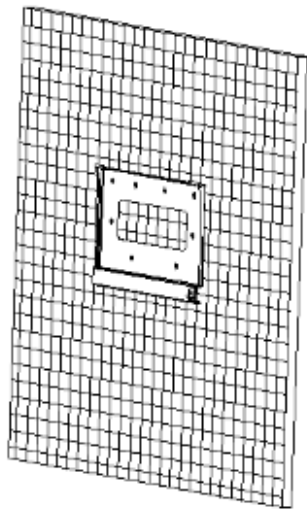

Step1

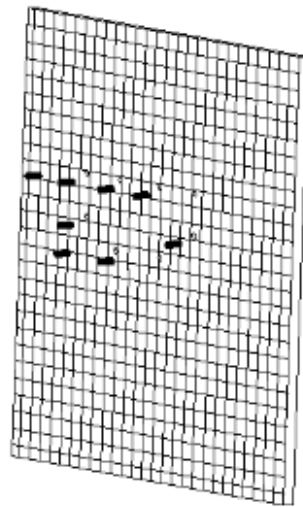

Step2

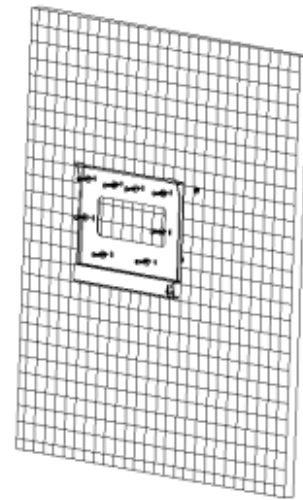

Step3

Step 4: Put ME3000SP on the mounting bracket.

Step 5: Earth ME3000SP using the grounding hole on the heat sink.

Step 6: OPTIONAL: you can lock ME 3000SP

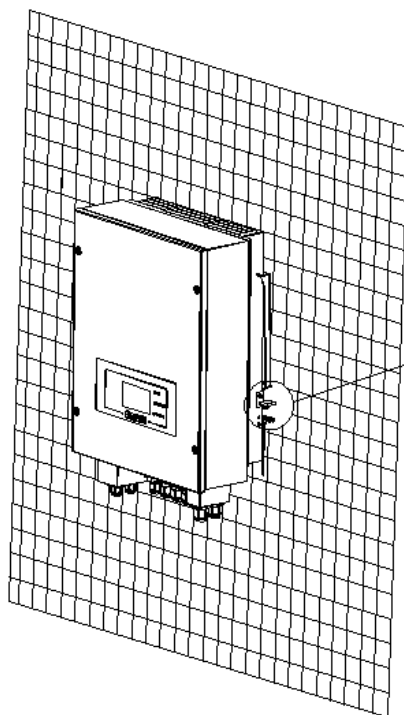

Step 5

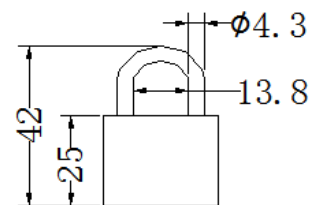
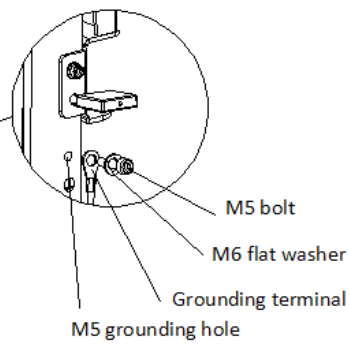

Step 6

## 4. Electrical Connection



**Warning**

- Be aware of electric shock and chemical hazards!
- Before connecting the battery, ensure the cable connectors have the correct polarity. Reversed polarity can damage ME3000SP!
- It's recommended to install a rotary DC isolator (100A) between ME3000SP and batteries. Thus ME3000SP can be securely disconnected during installation/maintenance.
- It's necessary to install a AC circuit breaker (25A) between ME3000SP and electrical grid.
- It is very important for system safety and efficient operation to use appropriate cable for electrical connection.
  - Battery connection: AWG6 cable. Grid & Load connection: AWG12 cable.
- Make sure N wire is connected to PE wire while EPS (Emergency Power Supply) mode is enabled.

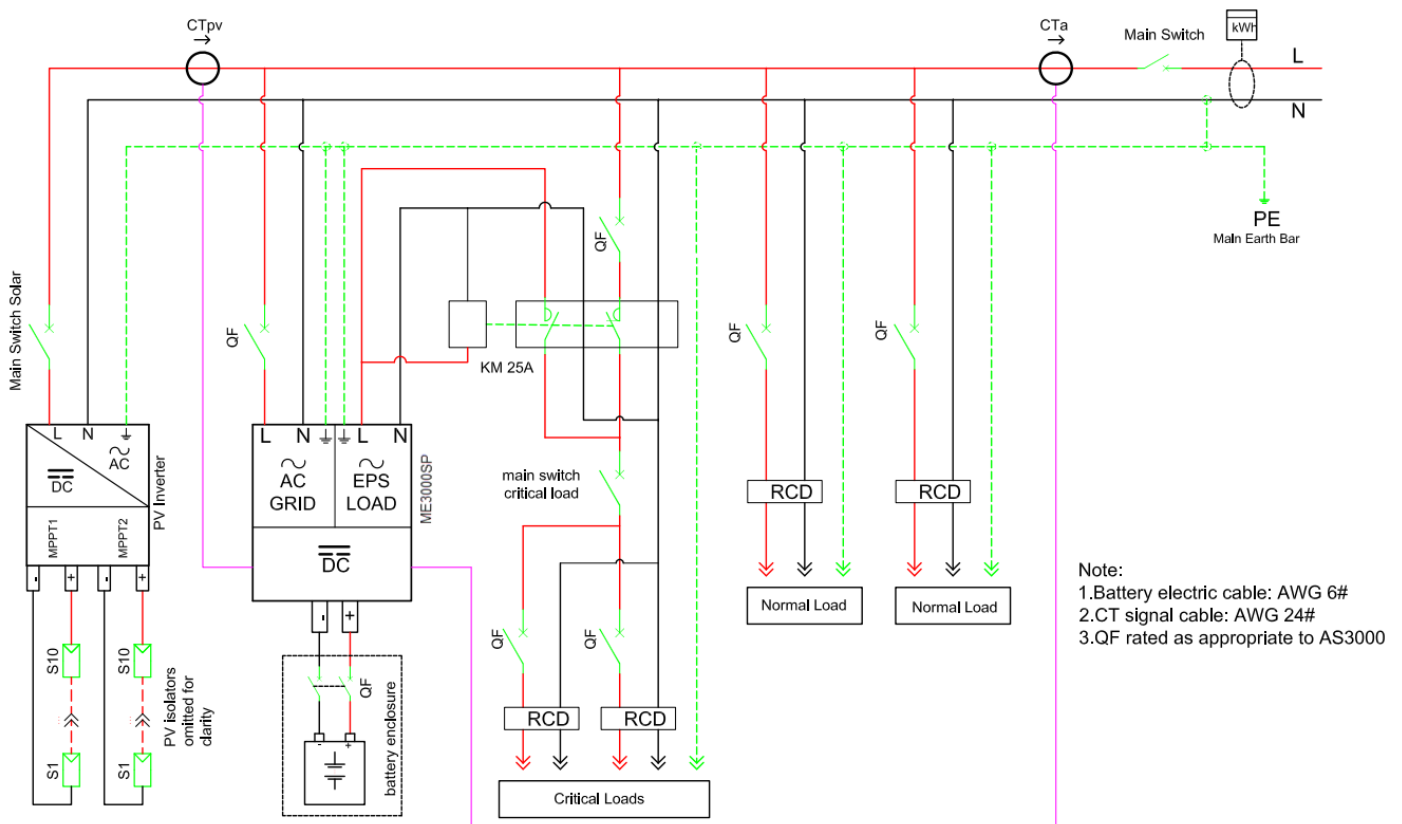

Fig. 5 Wiring Schematic of Single Phase System

## 4.1 Battery Connection

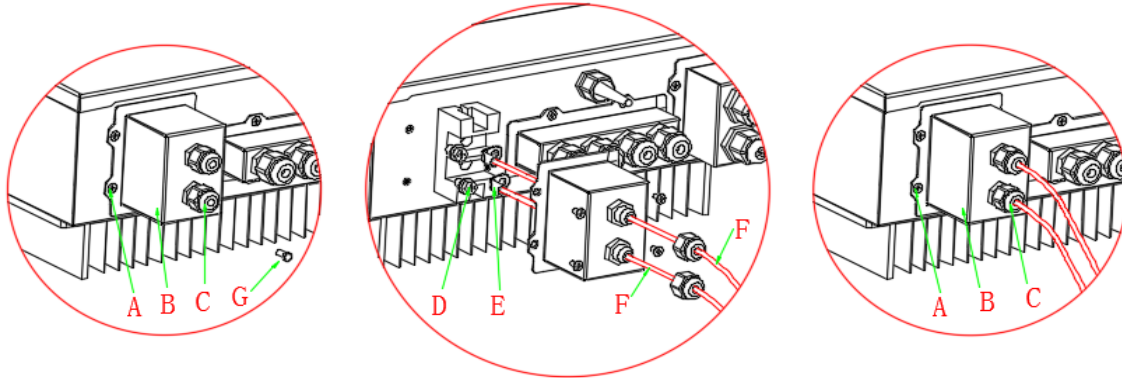

Fig. 6 Battery connection (Test battery wires polarity before connection)

Step 1: Loosen 4 screws (A) using a screwdriver (fig. 6);

Step 2: Remove the waterproof cover (B), loosen the cable gland (C), and then remove the stopper (G);

Step 3: Route the battery wires (F) through the cable gland, then connect battery wires using OT terminal (E);

Step 4: Fasten the waterproof cover using 4 screws.

## 4.2 CT / RS485 / NTC connection

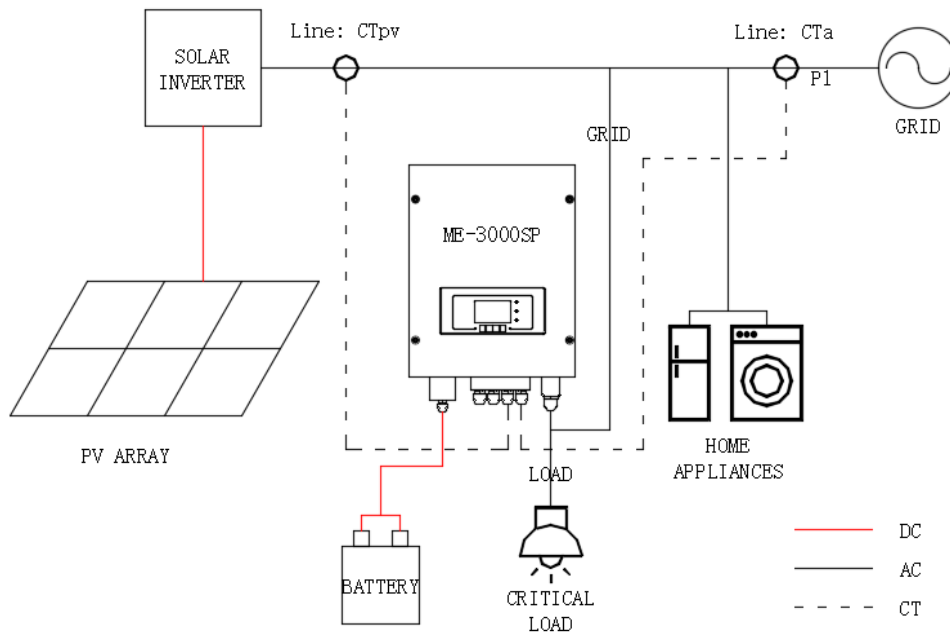

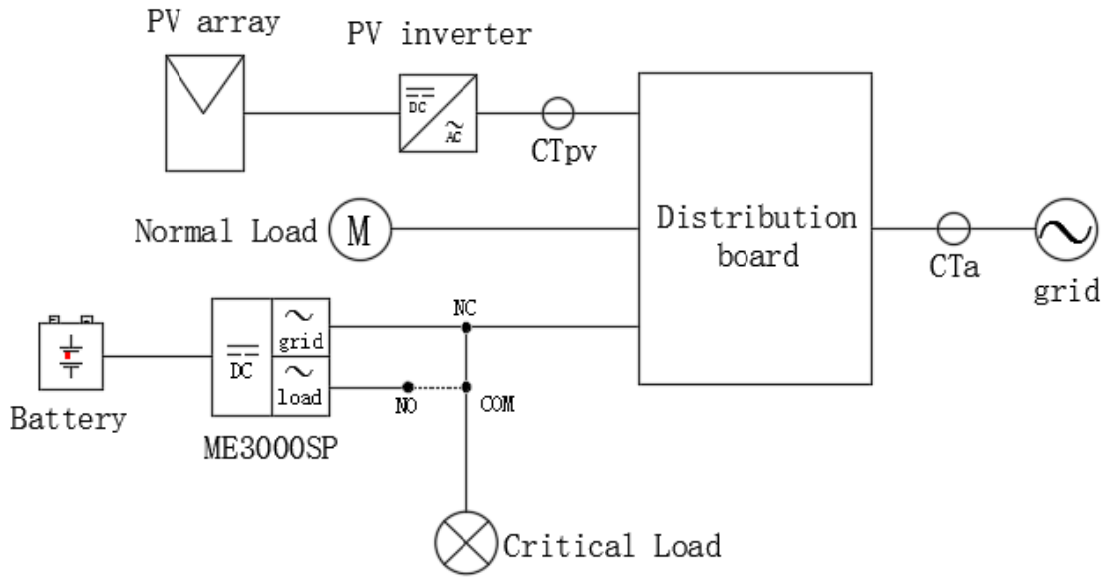

Fig. 7 Schematic Diagram (ME 3000SP: energy storage add-on to existing renewable system)

Step 1: Location of CTa: L wire of incoming mains. Location of CTpv: L wire of PV inverter's output.

Step 2: Use network cable & terminal caps to extend CT wires.

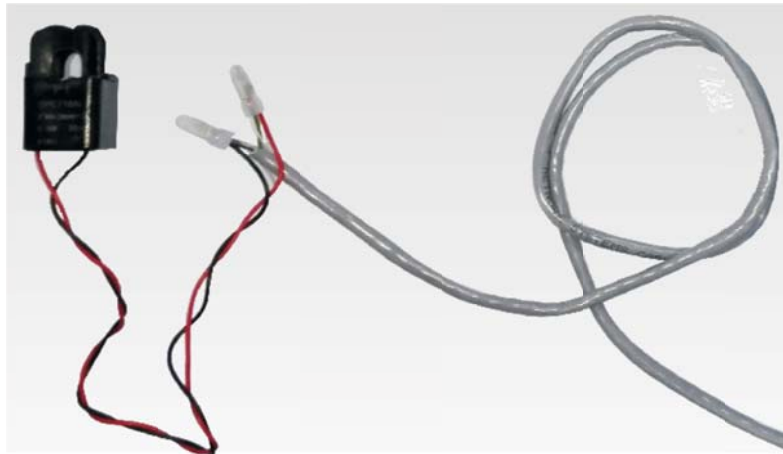

Fig. 8 CT wire extension

CT wire	Extension cable (network cable)	ME 3000SP
Red	Orange / white orange / brown / white brown	CT+
Black	Green / white green / blue / white blue	CT-

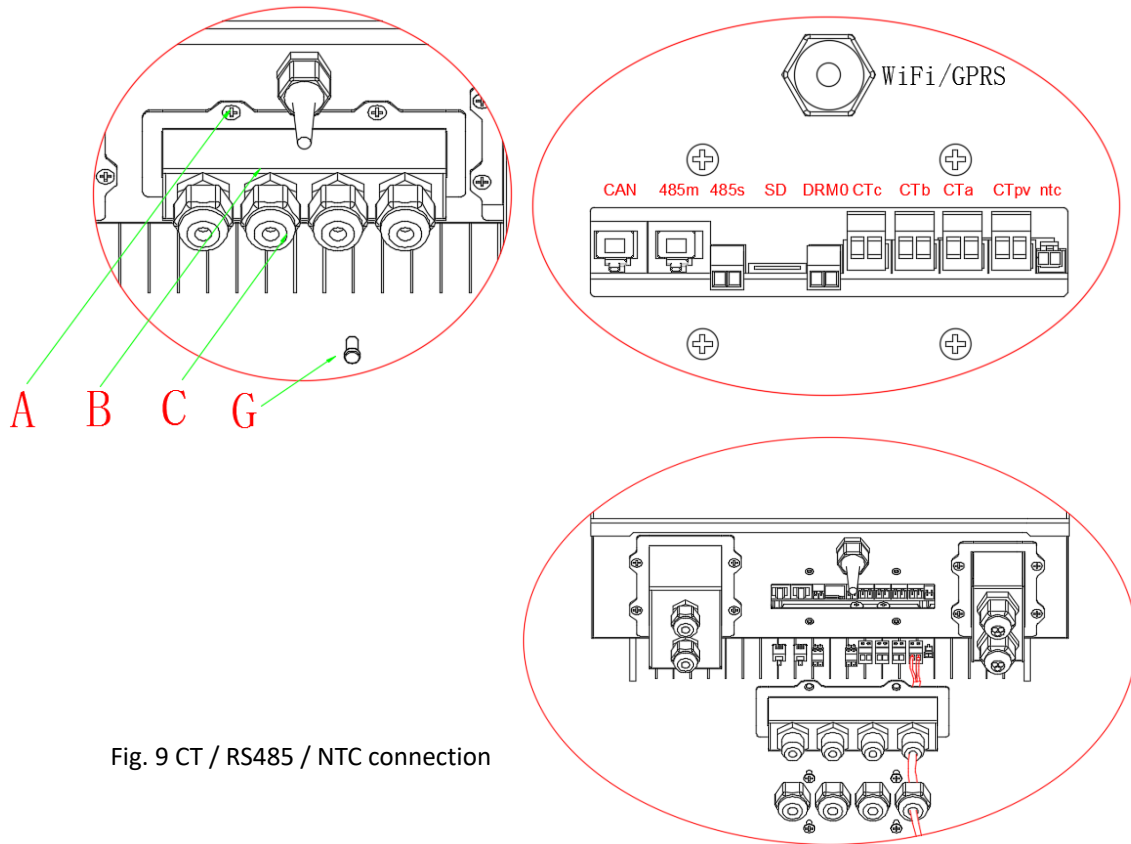

Fig. 9 CT / RS485 / NTC connection



Step 3: Loosen 4 screws (part A) using a screwdriver (fig. 9)

Step 4: Remove the waterproof cover (part B), loosen the cable gland (part C), then remove the stopper (part G)

Step 5: Route CT cable through the cable gland, connect CT cable to CT terminal, then insert CT terminal into corresponding ports.

Step 6: one communication cable is provided in the ME3000SP accessory bag. One inverter end, one battery end.

Route the communication cable (inverter end) through the cable gland, insert the 4P4C connector to 485M/CAN port.

	485 communication	CAN communication
	PYLONTECH US2000B RS485 port (firmware B63 or newer)	PYLONTECH US2000B CAN port (firmware B63 or newer)
	ME3000SP 485M port	ME3000SP CAN port



Step 7: Connect NTC for lead acid batteries only:

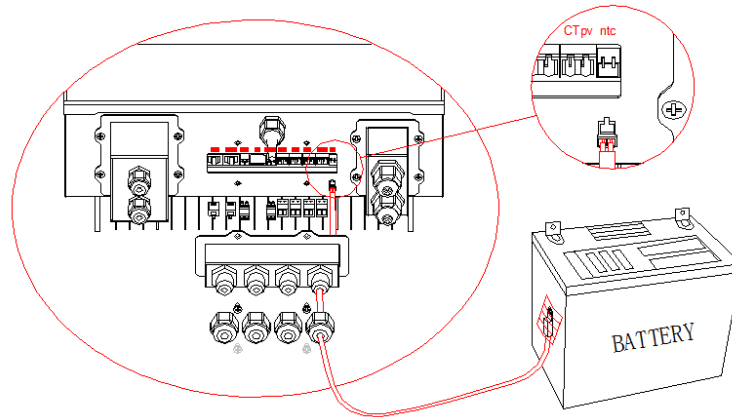

Fig. 10 NTC connection

Step 7: fasten the waterproof cover using 4 screws.

### 4.3 Grid Connection

For most of the customers, please ONLY connect the GRID port.

Please leave LOAD port unconnected.

Unless you need the EPS (Emergency Power Supply) function.

Step 1: Loosen 4 screws (part A) using a screwdriver (fig. 11)

Step 2: Remove the waterproof cover (part B), loosen the cable gland (part C), then remove the stopper (part G)

Step 3: Route a 3-core cable through GRID cable gland, then connect 3 wires to corresponding terminal blocks. (BROWN – L, BLUE – N, YELLOW/GREEN – PE)

Step 4: Fasten the waterproof cover using 4 screws.

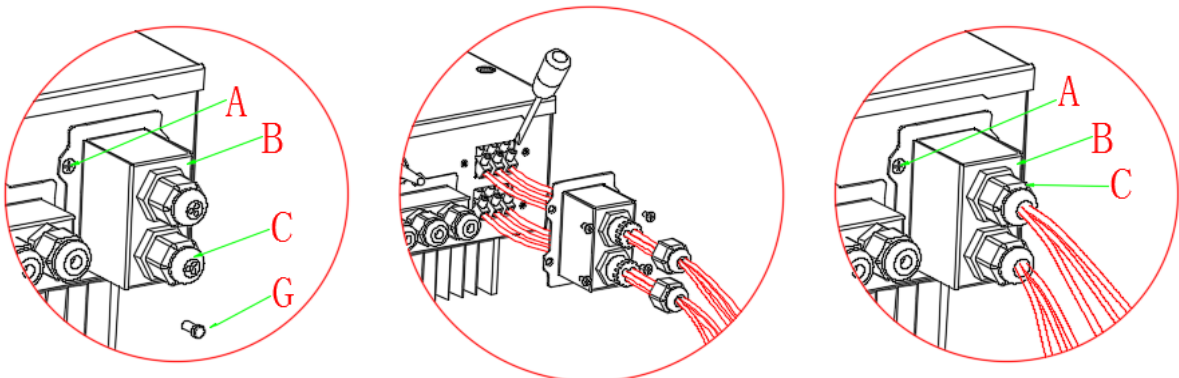
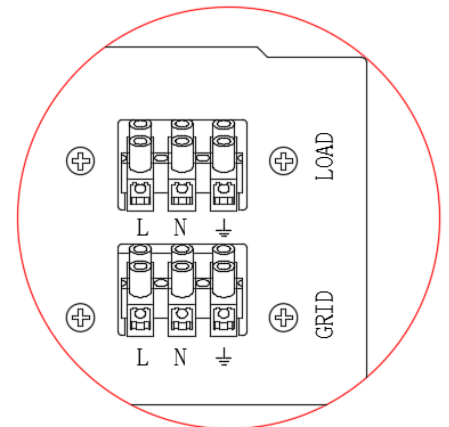

Fig. 11 Grid & Load connection

### 4.4 Critical Load Connection (EPS function)

Critical load: in case of grid outage, ME 3000SP will work in EPS (Emergency Power Supply) mode, discharge the battery & supply power to critical load via LOAD port.

LOAD port is only for critical load connection. Please make sure you've purchased the AC contactor from Shenzhen SOFARSOLAR Co., Ltd.

The connection procedure of LOAD port is the same as grid connection (Fig. 11).

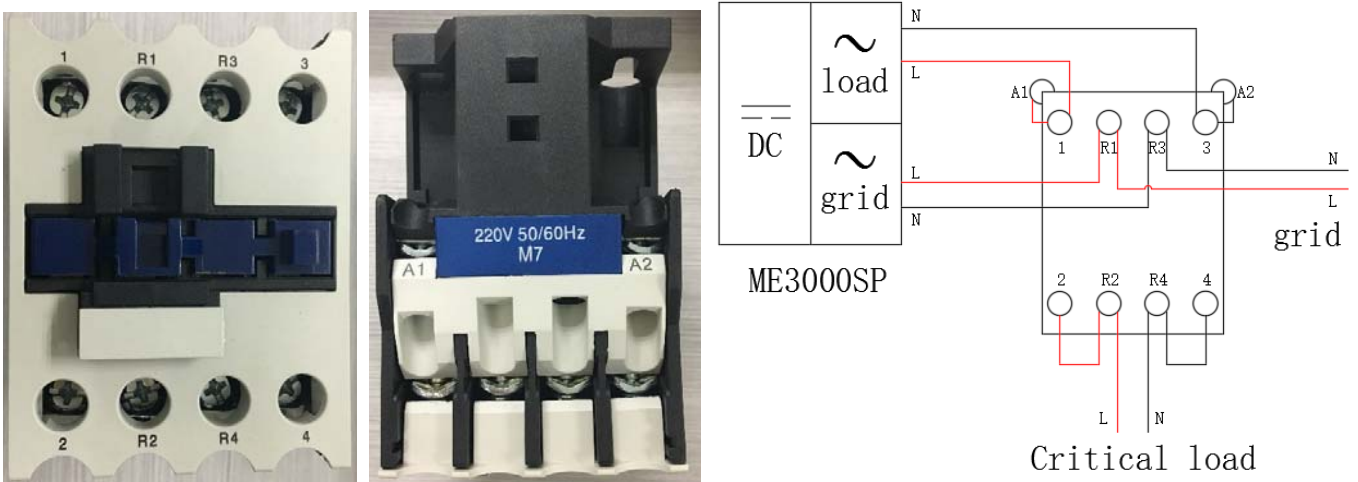

Fig. 12 AC contactor front view, top view, and connection

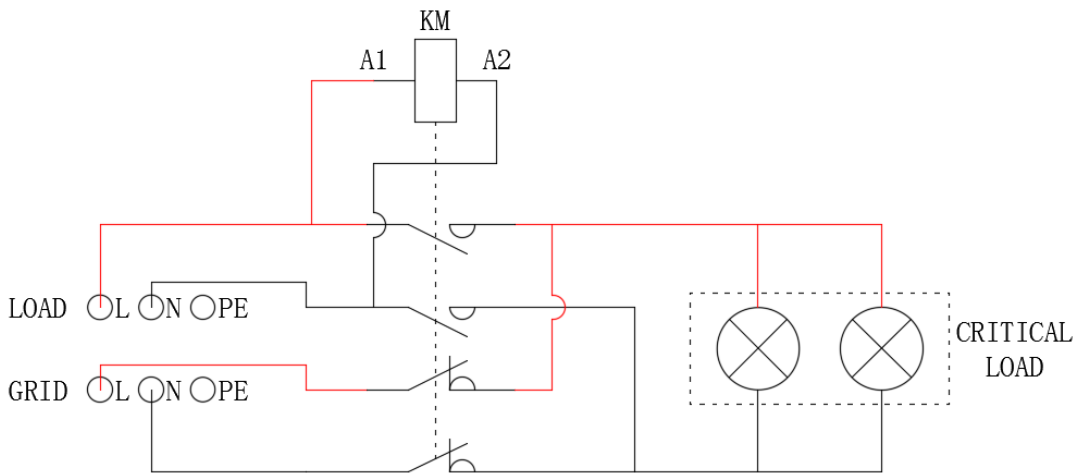
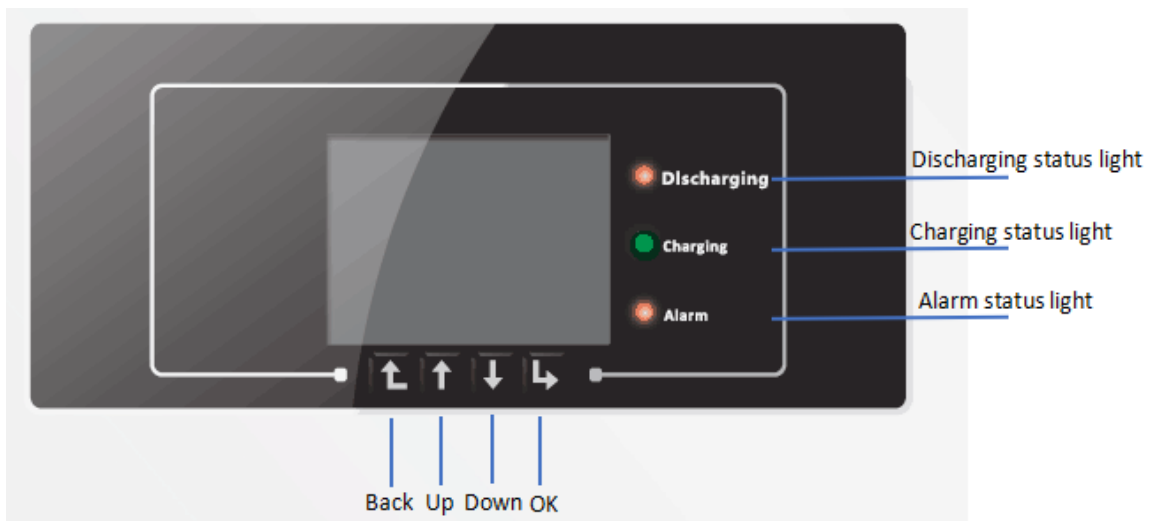

Fig. 13 Critical load connection (AC contactor: 2 NC, 2 NO)

## 5. Indicator lights and buttons



### 5.1 Buttons:

- press “Back” to the previous screen or enter the main interface;
- press “Up” to the upper menu option or value plus 1;
- press “Down” to the lower menu option or value minus 1;
- Press “OK” to select the current menu option or switch to the next digit.

### 5.2 Indicator lights:

- Discharging status Light (Green)
  - Discharging light flashing: system check before discharging the battery
  - Discharging light ON: discharging the battery
  - Discharging light OFF: system is faulty (fault, or permanent)
- Charging status Light (Green)
  - Charging light flashing: system check before charging the battery
  - Charging light ON: charging the battery
  - Charging light OFF: system is faulty (fault, or permanent)

- Alarm light (Red)

Alarm light ON: system is faulty (fault, or permanent)

### 5.3 Status of ME3000SP

Status of ME3000SP	Discharging Green Indicator light	Charging Green Indicator light	Alarm Red Indicator light
Discharge	ON		
Charge		ON	
Standby	Flashing	Flashing	
EPS state	ON	ON	
Fault			ON

## 6. Operation

### 6.1 Double Check

Please double check the following before operation.

1. ME3000SP is firmly fastened to the mounting bracket on the wall;
2. The polarity of battery wires is correct, battery wires are firmly connected;
3. DC isolator is correctly connected between battery & ME3000SP, DC isolator: OFF;
4. GRID / LOAD cables are firmly / correctly connected;
5. AC circuit breaker is correctly connected between ME3000SP GRID port & GRID, AC circuit breaker: OFF;
6. AC contactor is correctly connected (fig. 12);
7. For lithium battery, please ensure that the communication cable has been correctly connected;
8. For the lead-acid battery, please ensure that the NTC wire has been correctly connected.

### 6.2 First Time Setup (important!)

IMPORTANT: PLEASE FOLLOW THE FOLLOWING PROCEDURE to switch ON ME3000SP

- 1) Turn OFF PV inverter. Make sure there's no power generation in ME3000SP's phase.
- 2) Turn ON DC isolator between battery & ME 3000SP.

Only with PYLON

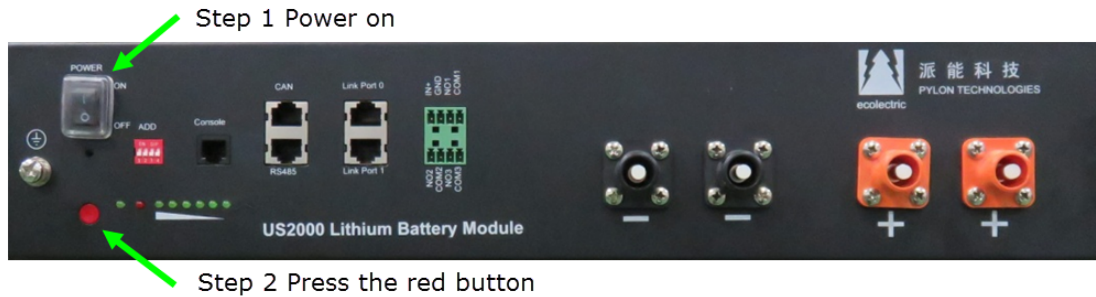

- 3) Turn ON AC circuit breaker between ME 3000SP GRID port & GRID. ME 3000SP should start to operate now.

You need to set the following parameters before ME3000SP start to operate.

1)Set system time	8)Set min discharge voltage
2)Set country	9)Set max discharge current
3)Select battery type	10)Set min protect voltage
4)Set battery capacity	11)Set discharge depth

5)Set max charge voltage	12)Set empty discharge voltage
6)Set max charge current	13)Set full charge voltage
7)Set max protect voltage	

### 1)Set system time

The format of System time is “YYYY-MM-DD-HH-MM-SS”, press “Up” or “Down” to change the 1<sup>st</sup> digit, press “OK” to switch to next digit, press “Ok” to complete the time setting. When the system setting is complete, then it will enter “country” setting automatically.

### 2)Set country

Press “Up” or “Down” to select a country, press “Ok” to complete the country setting, then it will enter “battery type” setting automatically.

CODE	Country	CODE	Country
00	Germany4105	14	Germany_0126
01	CEI021_INT	15	Italy_CEI0_16
02	Australia	16	UK_G83
03	SpainRD1699	17	Greece island
04	Turkey	18	EU_EN50438
05	Denmark	19	EU_EN61727
06	Greece Continent	20	Korea
07	Netherland	21	Sweden
08	Belgium	22	Europe general
09	UK_G59	23	CEI021_EXT
10	China	24	Cyprus
11	France	25	India
12	Poland	26	Philippines
13	Germany_BDEW	27	New Zealand

### 3)Select battery type

Press “Up” or “Down” to select the correct battery type, then press “Ok” to complete the battery type setting, then it will enter “battery capacity” setting automatically.

MENU	Suitable Battery
1.DARFON	DARFON EAA01 2.7KWH DARFON EIA02 5KWH
2.PYLON	PYLONTECH US2000B (BMS firmware should be B63 or newer)
3.TELE	TELE LEAD CRYSTAL

4.DEFAULT	LEAD ACID / AQUION
-----------	--------------------

Recommended settings for customers using PYLONTECH US2000B batteries:

Batteries parallel number	1 x US2000B	2 x US2000B	3 x US2000B	4 x US2000B
Battery type	PYLON	PYLON	PYLON	PYLON
Battery capacity	50Ah	100Ah	150Ah	200Ah
Max charge voltage	53.2V	53.2V	53.2V	53.2V
Max charge current	25.0A	50.0A	60.0A	60.0A
Max protect voltage	54.0V	54.0V	54.0V	54.0V
Min discharge voltage	47.2V	47.2V	47.2V	47.2V
Max discharge current	25.0A	50.0A	60.0A	60.0A
Min protect voltage	46.0V	46.0V	46.0V	46.0V
Discharge depth	80%	80%	80%	80%

4)Set battery capacity

Press “Up” or “Down” to change the 1<sup>st</sup> digit, press “OK” to switch to next digit. After inputting the battery capacity per your battery specification, press “Ok”, then it will enter “max charge voltage” setting automatically.

5)Set max charge voltage

Press “Up” or “Down” to change the 1<sup>st</sup> digit, press “OK” to switch to next digit. After inputting max charge voltage per your battery specification, press “Ok”, then it will enter “max charge current” setting automatically.

6)Set max Charge current

Press “Up” or “Down” to change the 1<sup>st</sup> digit, press “OK” to switch to next digit. After inputting the max charge current per your battery specification, press “Ok”, then it will enter “max protect voltage” setting automatically.

7)Set max protect voltage

Press “Up” or “Down” to change the 1<sup>st</sup> digit, press “OK” to switch to next digit. After inputting the max protect voltage per your battery specification, press “Ok”, then it will enter “min discharge voltage” setting automatically.

8)Set min discharge voltage

Press “Up” or “Down” to change the 1<sup>st</sup> digit, press “OK” to switch to next digit. After inputting the min discharge voltage per your battery specification, press “Ok”, then it will enter “max discharge current” setting automatically.

9)Set max discharge current

Press “Up” or “Down” to change the 1<sup>st</sup> digit, press “OK” to switch to next digit. After inputting the max discharge



current per your battery specification, press “Ok”, then it will enter “min protect voltage” setting automatically.

#### 10)Set min protect voltage

Press “Up” or “Down” to change the 1<sup>st</sup> digit, press “OK” to switch to next digit. After inputting the min protect voltage per your battery specification, press “Ok”, then it will enter “discharge depth” setting automatically.

#### 11)Set discharge depth

Press “Up” or “Down” to change the 1<sup>st</sup> digit, press “OK” to switch to next digit. After inputting the discharge depth per your battery specification, press “Ok”, then it will enter “empty discharge voltage” setting automatically.

#### 12)Set empty discharge voltage (valid for lead acid battery only)

Press “Up” or “Down” to change the 1<sup>st</sup> digit, press “OK” to switch to next digit. After inputting the empty discharge voltage per your battery specification, press “Ok”, then it will enter “full charge voltage” setting automatically.

#### 13)Set full charge voltage (valid for lead acid battery only)

Press “Up” or “Down” to change the 1<sup>st</sup> digit, press “OK” to switch to next digit. After inputting the full charge voltage per your battery specification, press “Ok”, ME 3000SP will display “Success”. The ME 3000SP’s first time setup is complete and press “Back” to return to the main interface. If “Fail” is displayed, ME 3000SP should be reset again.

## 6.3 Commissioning

After the completion of the above settings,

- 4) Turn ON some home appliances. Make sure power consumption in ME3000SP’s phase is greater than 200W. You should be able to read the power consumption reading on the screen.
- 5) Wait 1 minute. Turn ON PV inverter. You should be able to read the PV generation reading on the screen.

If power generation > power consumption, the battery is not full. ME 3000SP will charge the battery.

If power generation < power consumption, the battery is not flat. ME 3000SP will discharge the battery.

Every time you change the CT connection, you need to restart ME3000SP.

ME3000SP restart procedure:

Turn OFF PV inverter. Turn OFF AC circuit breaker (grid) / DC isolator (battery). Wait 2 minutes

Turn ON DC isolator (battery), then turn ON AC circuit breaker (grid). Wait 1 minute.

Turn ON PV inverter.



**The main interface:**

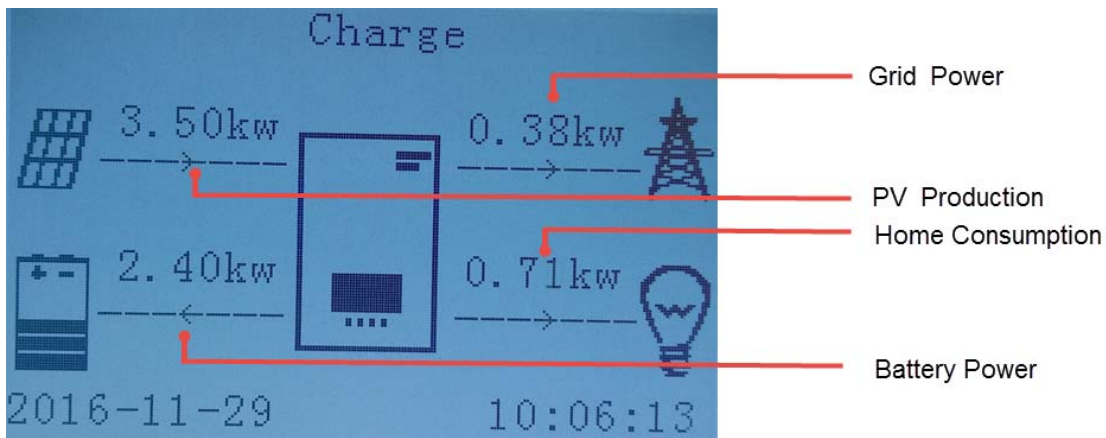

**6.4 Main Menu**

At the standard interface, press the “back” button to enter the main menu. The main menu includes five options: parameter settings, event list, system information, software upgrade, and energy statistics.

Main Menu
1.Enter Setting
2.Event List
3.System Information
4.Software Update
5.Energy Statistics

**6.4.1 Parameter setting:**

1.Enter Setting	
1.Batt Parameter	7.Set Language
2.Clear Energy Data	8.Set Time
3.Clear Events	9.Set EPS Mode
4.Set Country	10. DRMs0 Control
5.Set Communication Add	11. Auto Test
6.Function to Set Country	12. Work Mode Set

## 1. Batt Parameter

1. Batt Parameter	
1. Battery Type	7. Max. Discharge (A)
2. Battery Capacity	8. Low (V) Protection
3. Discharge Depth	9. Max. Charge (V)
4. Max. Charge (A)	10. Empty Charged Voltage
5. Over (V) Protection	11. Full Charged Voltage
6. Min. Discharge (V)	

Press “back” button to enter main menu, select “1. Enter Setting”, Press “OK”. Select “1. Batt Parameter” and press “OK”, “input password” is shown, press “OK” again. Input the password (normal “0001”, advanced “0715”), press “Up” or “Down” to change the 1<sup>st</sup> digit, press “OK” to switch to next digit, when “0001 / 0715” is shown on the screen, press “OK” to enter “Batt Parameter” interface. If “Error! Try again” is shown on the screen, press “Back” and input the password again.

### 1) Battery Type (refer to page 17)

Select “1. Battery Type” and press “OK”. Press “up” or “down” to select the battery type. Press “OK”.

### 2) Battery Capacity

Select “2. Battery Capacity” and press “OK”. Press “up” or “down” to change the 1<sup>st</sup> digit, press “ok” to switch to next digit. Input the value of battery capacity. Press “OK”.

### 3) Discharge Depth

Select “3. Discharge Depth” and press “OK”. Press “up” or “down” to change the 1<sup>st</sup> digit, press “ok” to switch to next digit. Input the value of Depth of Discharge per battery specification. Press “OK”.

For example: if Depth of Discharge = 80%, ME 3000SP won’t discharge the battery when its SOC (State of Charge) is less than 20%.

### 4) Max. Charge (A)

Select “4. Max. Charge (A)” and press “OK”. Press “up” or “down” to change the 1<sup>st</sup> digit, press “ok” to switch to next digit. Input the value of Max. Charge (A) per battery specification. Press “OK”.

### 5) Over (V) Protection

Select “5. Over (V) Protection” and press “OK”. Press “up” or “down” to change the 1<sup>st</sup> digit, press “ok” to switch to next digit. Input the value of Over (V) Protection per battery specification. Press “OK”.

### 6) Min. Discharge (V)

Select “6. Min. Discharge (V)” and press “OK”. Press “up” or “down” to change the 1<sup>st</sup> digit, press “ok” to switch to next digit. Input the value of Min. Discharge (V) per battery specification. Press “OK”.

### 7) Max. Discharge (A)

Select “7. Max. Discharge (A)” and press “OK”. Press “up” or “down” to change the 1<sup>st</sup> digit, press “ok” to switch to next digit. Input the value of Max. Discharge (A) per battery specification. Press “OK”.

### 8) Low (V) Protection



Select "8. Low (V) Protection" and press "OK". Press "up" or "down" to change the 1<sup>st</sup> digit, press "ok" to switch to next digit. Input the value of Low (V) Protection per battery specification. Press "OK".

#### 9) Max. Charge (V)

Select "9. Max. Charge (V)" and press "OK". Press "up" or "down" to change the 1<sup>st</sup> digit, press "ok" to switch to next digit. Input the value of Max. Charge (V) per battery specification. Press "OK".

#### 10) Empty Charged Voltage (only valid for lead acid batteries)

Select "10. Empty Charged Voltage" and press "OK". Press "up" or "down" to change the 1<sup>st</sup> digit, press "ok" to switch to next digit. Input the value of Empty Charged Voltage per battery specification. Press "OK".

#### 11) Full Charged Voltage (only valid for lead acid batteries)

Select "11. Full Charged Voltage" and press "OK". Press "up" or "down" to change the 1<sup>st</sup> digit, press "ok" to switch to next digit. Input the value of Full Charged Voltage per battery specification. Press "OK".

### 2. Clear Energy Data

Select "2. Clear Energy" and press "OK", "input password" is shown, press "OK" again. Input the password "0001", press "Up" or "Down" to change the 1<sup>st</sup> digit, press "OK" to switch to next digit, when "0001" is shown on the screen, press "OK". If "Error! Try again" is shown on the screen, press "Back" and input the password again.

### 3. Clear Events

Select "3. Clear Events", press "OK" button twice to clear all the events.

### 4. Set Country (refer to page 17)

Select "4. Set Country", press "OK", "Input Country Code" is shown, press "OK", if "Set Disable" is shown, you need to go to "6. Function to Set Country" to enable country setting, then return to "4. Set Country" to input the country code (refer to Page 17 of this manual). Press "OK".

### 5. Set Communication Add

Select "5. Set Communication Add", press "OK" button twice to enter Communication Address setting interface. Press "Up" or "Down" to change the 1<sup>st</sup> digit, press "OK" to switch to next digit, after inputting the communication address, press "OK".

### 6. Function to Set Country

Select "6. Function to Set Country", press "OK", "input password" is shown, press "OK" again. Input the password "0001", press "Up" or "Down" to change the 1<sup>st</sup> digit, press "OK" to switch to next digit, when "0001" is shown on the screen, press "OK". If "Error! Try again" is shown on the screen, press "Back" and input the password again.

### 7. Set Language

Select "7. Set Language", press "OK". Press "up" or "down" to select the language and press "OK".

### 8. Set Time

Select "8. Set Time", press "OK" to enter into time setting interface, the format of the time is YYYY-MM-DD HH:MM:SS. Press "Up" or "Down" to change the 1<sup>st</sup> digit, press "OK" to switch to next digit, after inputting the current time, press "OK".

**9. Set EPS (Emergency Power Supply) Mode**

MENU		
9. Set EPS Mode	1.EPS Mode Control	1.Enable EPS Mode
		2.Disable EPS Mode
	2.Set EPS Changeover Time	*** seconds

**10. DRMs0 Control (This part is valid for Australian Market ONLY)**

Select "10. DRMs0 Control", press "OK", "input password" is shown, press "OK" again. Input the password "0001", press "Up" or "Down" to change the 1<sup>st</sup> digit, press "OK" to switch to next digit, when "0001" is shown on the screen, press "OK". After entering DRMs0 control interface, press "up" or "down" to select "1. Enable DRMs0" or "2. Disable DRMs0", press "OK".

**11. Auto Test (This part is valid for Italian Market ONLY)**

Select "11. Auto Test", press "OK" to enter autotest interface.

11.Auto Test		
1.Autotest Fast	4.Setting QV time	
2.Autotest STD	5.Control 81.S1	
3.Setting Pf time		

1) Autotest Fast

After entering Auto Test interface, press "up" or "down" to select "1. Autotest Fast", then press "OK" to start Auto test Fast.

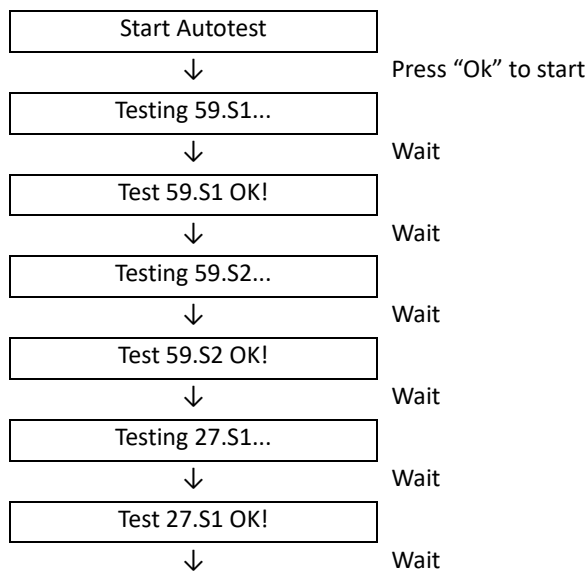

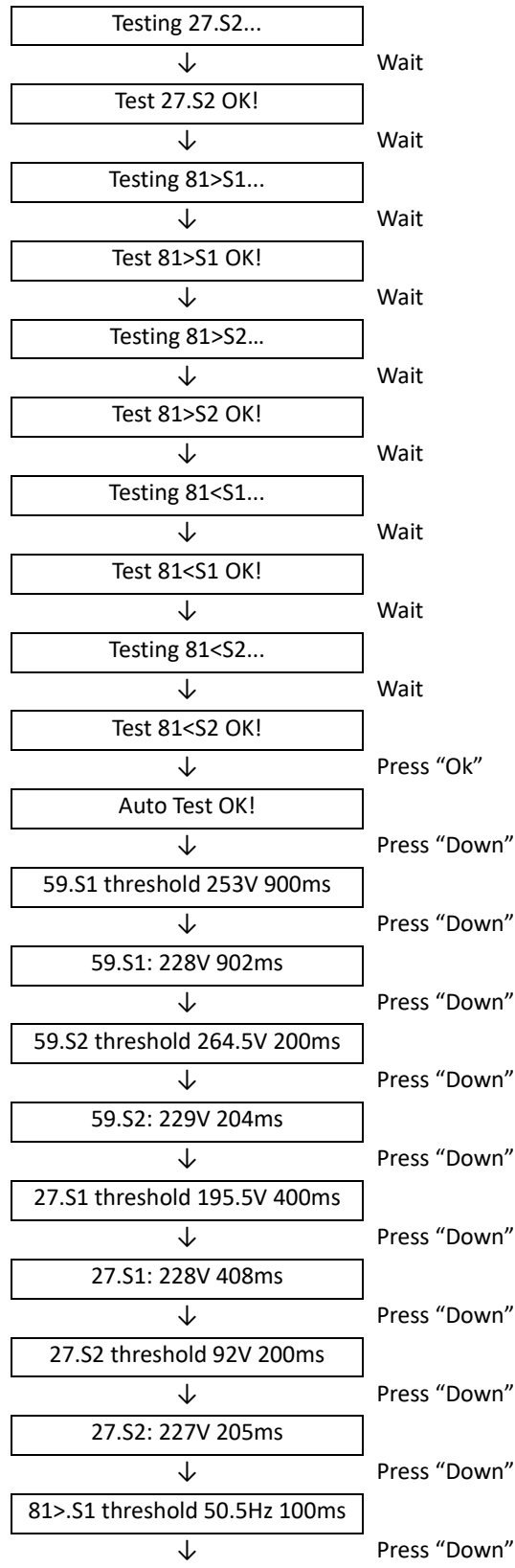

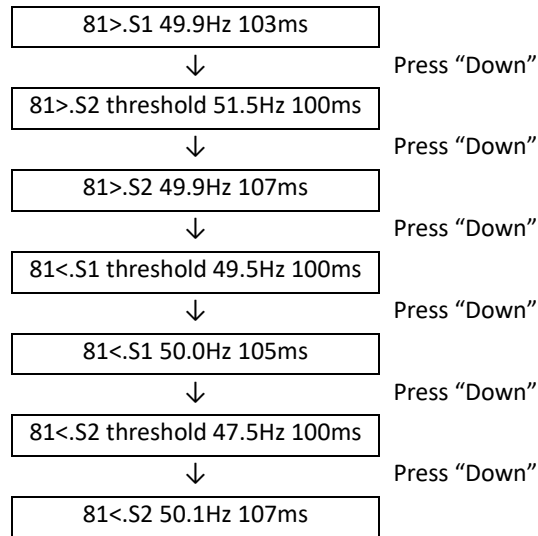

2) Autotest STD

After entering Auto Test interface, press "up" or "down" to select "2.Autotest STD", then press "OK" to start Auto test STD.

The test procedure is same as Autotest Fast, but it takes much longer time.

3) Setting Pf time

After entering Auto Test interface, press "up" or "down" to select "3.Setting Pf time", then press "OK" to enter Setting Pf time interface.

After entering Setting Pf time interface, it will display as below:

Set: \*. \*\*\* s

\*. \*\*\* is the time value need to be set. Press "Up" or "Down" to change the 1<sup>st</sup> digit, press "OK" to switch to next digit. After inputting numbers for all digits, press "OK".

4) Setting QV time

After entering Auto Test interface, press "up" or "down" to select "4.Setting QV time", then press "OK" to enter Setting QV time interface.

After entering Setting QV time interface, it will display as below:

Set : \*\* s

\*\* is the time value needing to be set. Press "Up" or "Down" to change the 1<sup>st</sup> digit, press "OK" to switch to next digit. After inputting numbers for all digits, press "OK".

5) Control 81.S1

After entering Auto Test interface, press "up" or "down" to select "5.Control 81.S1". After entering control 81.S1 interface, press "up" or "down" to select "1. Enable 81.S1" or "2. Disable 81.S1", press "OK".

## 12. Work Mode Set

Select "12. Work Mode Set", press "OK" to enter work mode setting interface.

12.Work Mode Set
1.Set Auto Mode
2.Set Time-of-use Mode
3.Set Timing Mode

### 1) Set Auto Mode

Select "1. Set Auto Mode", then press "OK".

In auto mode, the device will automatically determine the charging time & discharging time, & ensure that the battery SOC (State of Charge) won't be too low.

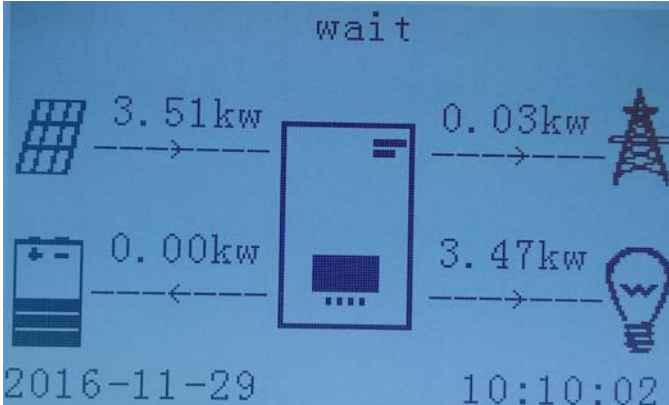
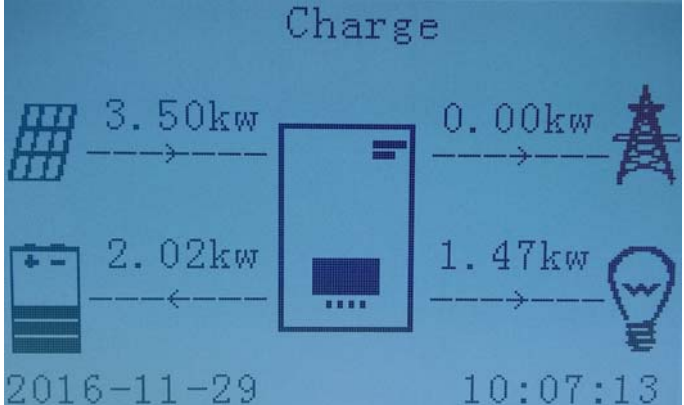
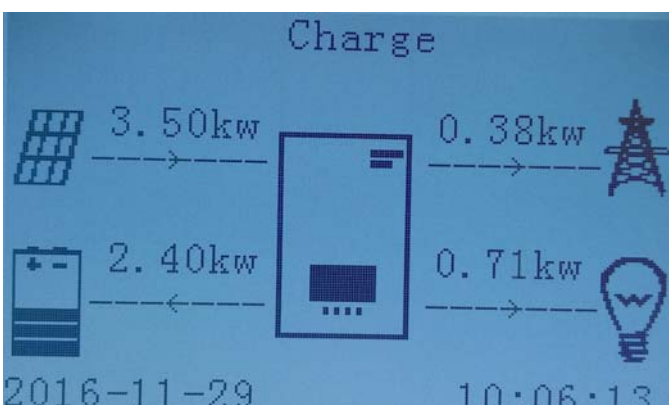
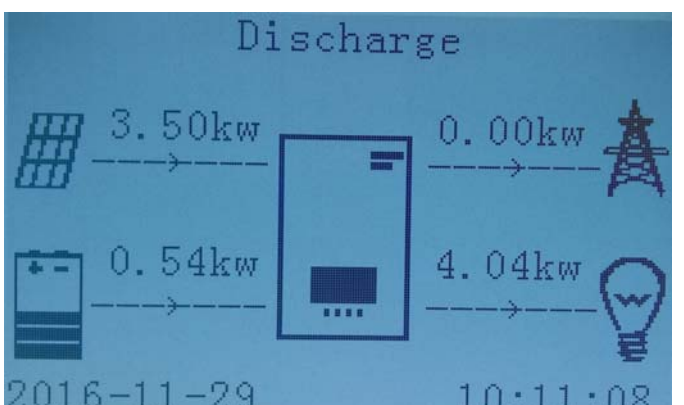
<p>1) PV generation = LOAD consumption (<math>\Delta P &lt; 100W</math>), ME 3000SP will stay in Standby state.</p> 	<p>2) PV generation &gt; LOAD consumption, the surplus power will be stored in the battery firstly.</p> 
<p>3) When the battery is full(or already at Max Charge Power), excess power will be exported to the grid.</p> 	<p>4) PV generation &lt; LOAD consumption, discharge the battery to supply power to load firstly,</p> 
<p>5) If PV generation + Battery &lt; LOAD consumption, ME</p>	<p>6) Press "DOWN" button to check current detailed</p>

3000SP will import power from the grid.

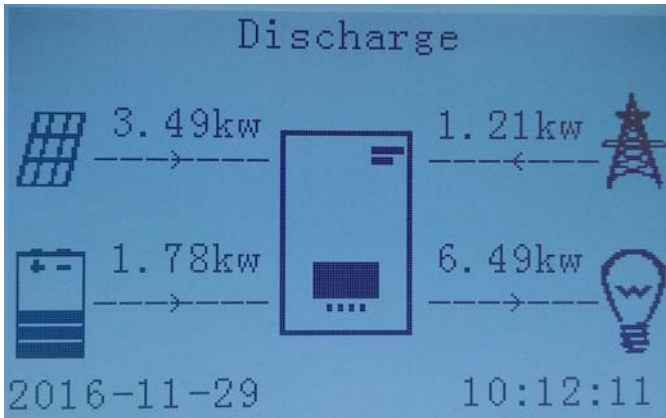

information, press "UP" to get back to main interface.

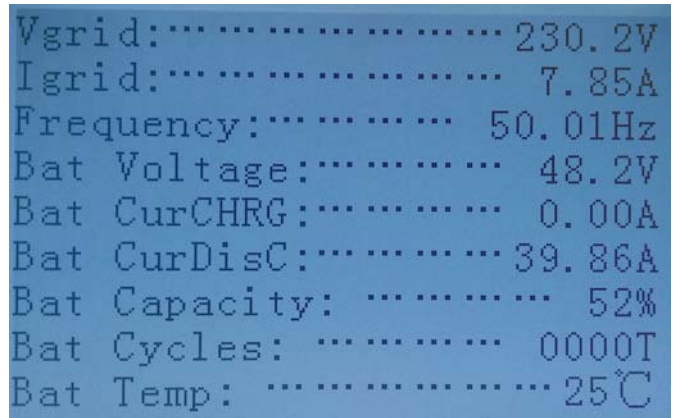

2) Set Time-of-use Mode

Select "2.Set Time-of-use Mode", and then press "OK" to enter Set Time-of-use mode interface. End user can set a off-peak time period (evening charging time period) and target SOC (State Of Charge to terminate evening charging). The interface of Time-of-use Mode is shown as below. This mode is for customers who have TOU (Time-of-use) pricing electricity (cheaper rate in off peak time & more expensive rate in peak time) and owning a PV on-grid system.

For example:

- a) From 9:00PM to 6:00AM, the electricity is cheap, ME 3000SP will import power from grid & charge the battery to a preset SOC.
- b) From 6:00AM to 8:00AM, the electricity is expensive and the PV generation is quite low, ME3000SP will discharge the battery to supply the morning peak consumption;
- c) From 8:00AM to 7:00PM, PV generation > LOAD consumption, the surplus PV power will be stored in the battery;
- d) From 7:00PM to 9:00PM, the electricity is expensive and PV generation is quite low, ME3000P will discharge battery to supply the night peak consumption;

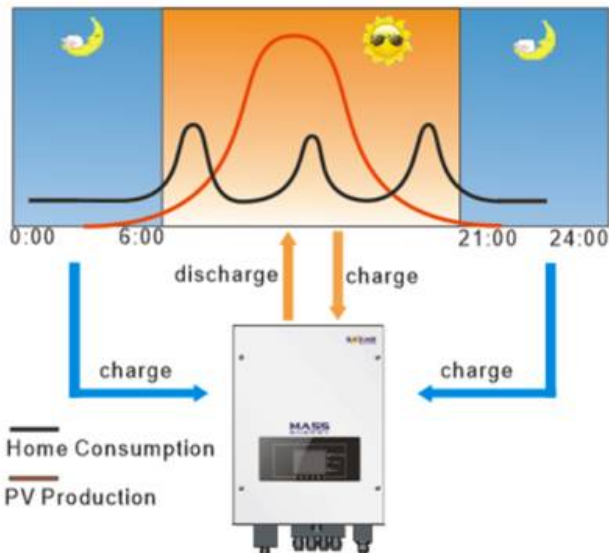

Charge Start:	21 h 00 m
Charge End:	06 h 00 m
Set Aimed SOC	080 %



3) Set Timing Mode

Select “3. Set Timing Mode”, and then press “OK” to enter Set Timing mode interface. End user can set an off-peak period (evening charging time period) & a peak time period (daylight discharging time period) & corresponding powers. The interface of Set Timing Mode is shown as below. This mode is for customers who have TOU (Time-of-use) pricing electricity (cheaper rate in off peak time & more expensive rate in peak time).

Charge Start	22 h 00 m
Charge End	05 h 00 m
Charge Power	2000 W
DisCharge Start	14 h 00m
DisCharge End	16 h 00m
DisCharge Power	2500 W

6.4.2 Event List

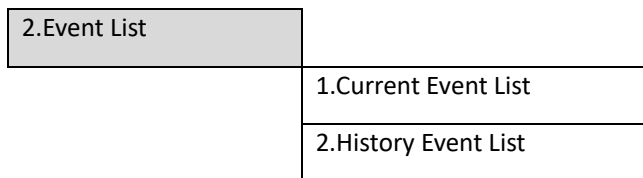

Event list of ME 3000SP, including current event list and history event list.

1) Current Event List

Select “1. Current Event List”, press “OK” to check the current events.

2) History Event List

Select “2. History Event List”, press “OK” to check the history events. Press “up” or “down” to check all history events if there’re more than 1 pages of events.

6.4.3 System information interface

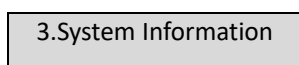

1.Product SN	8.Work Mode
2.Software Version	9. DRMs0 Control
3.Hardware Version	10.Batt Parameter
4.RS485 Address	11.Setting Pf time
5.Country	12.Setting QV time
6.Power Factor	13. Default Pf time
7.EPS Mode	14. Default QV time

### 6.4.4 Software upgrade

Select “4. Software Update” in the main menu, press “OK”, “input password” is shown, press “OK” again. Input the password (“0715”), press “Up” or “Down” to change the 1<sup>st</sup> digit, press “OK” to switch to next digit, when “0715” is shown on the screen, press “OK”. ME 3000SP will start to upgrade the software automatically.

**Upgrading Procedure:**

**Step 1** Turn off AC circuit breaker (grid) and DC isolator (battery), then remove communication waterproof cover. If communication cables (RS485/NTC/CT) have been connected, loosen their cable glands before removing cover.

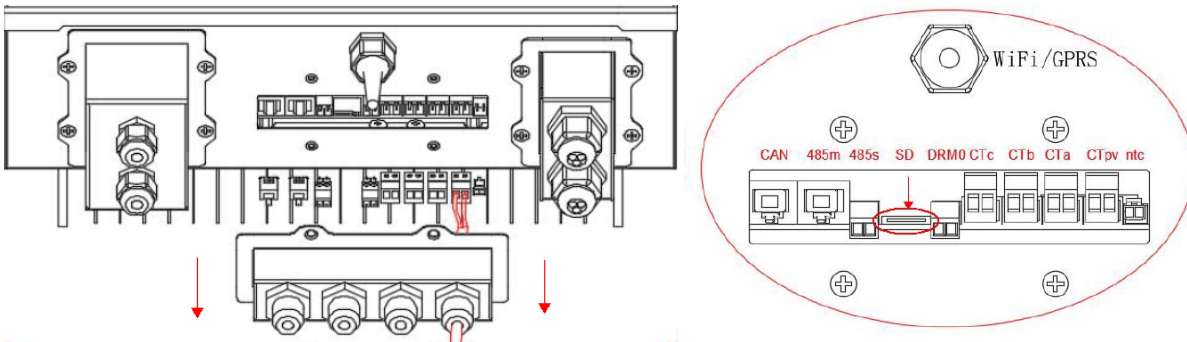

**Step 2** Press the SD card and take it out. Insert the SD card into a micro-SD card reader, then insert micro-SD card reader into a PC; (NOTE: micro-SD card reader & PC are not provided by SOFARSOLAR).

**Step 3** Format the SD card. Copy the “ES3000firmware” folder to the SD card. (ask our technical support [service@sofarsolar.com](mailto:service@sofarsolar.com) to send you the latest software)

**Step 4** Insert the SD card into the SD card slot. You will hear a click sound.

**Step 5** Then turn on DC isolator (battery), wait 5 seconds, turn ON AC circuit breaker (grid), press “Back” to enter main menu. Press “Down” to select “4. Software Update”, then press “Ok”.

**Step 6** “input password” is shown, press “OK” again. Input the password (“0715”), press “Up” or “Down” to change the 1<sup>st</sup> digit, press “OK” to switch to next digit, when “0715” is shown on the screen, press “Ok” to start software update.



**Step 7** After the update is complete, turn OFF AC circuit breaker (grid) and DC isolator (battery), lock the communication waterproof cover with four screws, then turn ON DC isolator (battery), wait 5 seconds, turn ON AC circuit breaker (grid), ME 3000SP will start to operate automatically.

NOTE: If “DSP communicate fail”, “Update DSP1 Fail” or “Update DSP2 Fail” is shown on the screen, which means the software upgrade is unsuccessful, please turn OFF AC circuit breaker (grid) and DC isolator (battery), wait 2 minutes, then start again from “**Step 5**”

### 6.4.5 Energy Statistics :

5. Energy Statistics		
	Today	
Renewable	100.00KWh	
Self-Use	80.00KWh	80%
Export	20.00KWh	20%
For Load	100.00KWh	
Self-Use	80.00KWh	80%
Import	20.00KWh	20%

Select “5. Energy Statistics” in the main menu, press “OK” to enter Energy Statistics interface, it shows the energy generation and consumption within a certain range of time. Press “Up” or “Down” to check the daily / weekly / monthly / yearly / lifetime statistics.

## 7. Technical Data

Technical Data		ME 3000SP
<b>BATTERY PARAMETERS</b>		
Battery Type	Lead-acid,Lithium-ion	
Nominal battery voltage	48V	
Battery voltage range	42-58V	
Recommended battery capacity	200Ah (100~500Ah optional)	
Recommended Storage capacity	9.6kWh	
Max.Charging Current	60A	
Charging Current Range	0-60A(Programmable)	
Charging curve	3-stage adaptive with maintenance	
Max.Discharging Current	60A	
Electronic protection	OCP OTP OVP	
Short circuit protection	Fuse (100A)	
Discharge times (Hour)	Po=1kVA 9.6h	
	Po=3kVA 3.2h	
Depth of discharge	Lithium : 0~80%DOD adjustable	
	Lead-acid:0~50%DOD adjustable	
<b>AC PARAMETERS</b>		
Max.Output Power	3kVA	
Rated Input/Output Voltage	230V	
Max.Input/Output Current	13A	
AC Input/Voltage Range	180V-270V	
Grid Frequency Range	44~55Hz / 54~66Hz	
THD	<3%	
Power Factor	1(Adjustable +/-0.8)	
Connection phase	single	
Current(inrush)	0.8A/1us	
Maximum output fault current	100A/1us	
Maximum output overcurrent protection	13A	
<b>SYSTEM PARAMETERS</b>		
Max.Charging Efficiency	94.1%	
Max.Discharging Efficiency	94.3%	
Standby Losses	<5W	
Topology	High Frequency Isolated Transformer	
Degree Of Protection	IP65	
Safety Protection	Anti islanding, RCMU, Ground Fault Monitoring	
Certification	AS4777,VDE0126-1-1,G83/2,C10/11,RD1699,UTEC15-712-1,EN50438,VDE-AR-N4105	
Communication	WiFi,RS485,CAN2.0	
<b>ENVIRONMENTAL</b>		
Ambient temperature range	-25°C...+60°C (Above 45°Derating)	
Allowable Relative Humidity Range	0... 100%, No Condensing	
Protective Class	Class I	
Max.Operating Altitude	2000m	
Current Sensor Connection	external	
<b>GENERAL DATA</b>		
Noise	<25dB	
Weight	16kg	
Cooling	Natural	
Dimension(W*H*D)	532*360*173mm	
Display	LCD display	
Warranty	5 Years (Optional: extension to 10 years)	
<b>Emergency Power Supply</b>		
EPS rated power	3000VA	
EPS rated voltage, Frequency	230V,50/60Hz	
EPS rated current	13A	
Total harmonic distortion	<3%	
Switich time	<3s	

## 8. Troubleshooting

Code	Name	description	solution
ID01	GridOVP	The power grid voltage is too high	<p>If the alarm occurs occasionally, the possible cause is that the electric grid is abnormal occasionally. ME3000SP automatically returns to normal operating status when the electric grid's back to normal.</p> <p>If the alarm occurs frequently, check whether the grid voltage/frequency is within the acceptable range. If no, contact technical support. If yes, check the AC circuit breaker and AC wiring of the ME3000SP.</p> <p>If the grid voltage/frequency is within the acceptable range and AC wiring is correct, while the alarm occurs repeatedly, contact technical support to change the grid over-voltage, under-voltage, over-frequency, under-frequency protection points after obtaining approval from the local electrical grid operator.</p>
ID02	GridUVP	The power grid voltage is too low	
ID03	GridOFP	The power grid frequency is too high	
ID04	GridUFP	The power grid frequency is too low	
ID05	BatOVP	The battery voltage is too high	<p>If the alarm occurs occasionally, the possible cause is during the process of charging.</p> <p>If the alarm occurs occasionally, check whether the overvoltage setting of the battery consistent with the parameter of battery manufacturer and contact technical support.</p>
ID09	HW_LLCCBus_OVP	LLCCBus voltage is too high and has triggered hardware protection	<p>ID09- ID26 are internal faults of ME3000SP, turn OFF the "DC &amp; AC switch", wait for 5 minutes, then turn ON the "DC switch" and turn ON the "AC switch". Check whether the fault is rectified. If no, please contact technical support.</p>
ID10	HW_Boost_OVP	Boost voltage is too high and has triggered hardware protection	
ID11	HwBuckBoostOCP	BuckBoost current is too high and has triggered hardware protection	
ID12	HwBatOCP	The battery current is too high and has triggered hardware protection	
ID15	HwAcOCP	The grid current is too high and has triggered hardware protection	
ID17	HwADFaultIGrid	The grid current sampling error	
ID18	HwADFaultDCI	The DCI sampling error	
ID19	HwADFaultVGrid	The grid voltage sampling error	
ID21	MChip_Fault	The master chip fault	

ID22	HwAuxPowerFault	The auxiliary voltage error	
ID25	LLCBusOVP	LLCBus voltage is too high	
ID26	SwBusOVP	Bus voltage is too high and has triggered software protection	
ID27	BatOCP	Battery current is too high	If the fault occurs frequently, please contact technical support.
ID28	DciOCP	The DCI is too high	ID28-ID55 are internal faults of ME3000SP, turn OFF the "DC&AC switch", wait for 5 minutes, then turn ON the "DC switch" and turn ON the "AC switch". Check whether the fault is rectified. If no, please contact technical support.
ID29	SwOCPIstant	The grid current is too high	
ID30	BuckOCP	Buck current is too high	
ID31	AcRmsOCP	The output current is too high	
ID49	ConsistentFault_VGrid	The grid voltage sampling value between the master DSP and slave DSP is not consistent	
ID50	ConsistentFault_FGrid	The grid frequency sampling value between the master DSP and slave DSP is not consistent	
ID51	ConsistentFault_DCI	The Dci sampling value between the master DSP and slave DSP is not consistent	
ID52	BatCommunicationFlag	Battery communication fault	
ID53	SpiCommLose	SPI communication is fault	
ID54	SciCommLose	SCI communication is fault	
ID55	RecoverRelayFail	The relays fault	
ID57	OverTempFault_BAT	The battery temp is too high	ID57-ID59 Check whether the air condition around the equipment is good. Or set the "max discharging & charging current "a little lower to check whether the fault is rectified. If the fault occurs frequently, please contact SOFAR technical support.
ID58	OverTempFault_HeatSink	The temperature of heat sink is too high	
ID59	OverTempFault_Env	The environment temp is too high	
ID65	unrecoverHwAcOCP	The grid current is too high and has cause unrecoverable hardware fault	ID65-ID77 are internal faults of ME3000SP, turn OFF the "DC switch", wait for 5 minutes, then turn ON the "DC switch" and turn ON the "AC switch". Check whether the fault is rectified. If no, please contact SOFAR technical support.
ID66	unrecoverBusOVP	The bus voltage is too high and has cause unrecoverable fault	
ID67	BitEPSunrecoverBatOcP	Unrecoverable fault of battery overcurrent in EPS mode	
ID70	unrecoverOCPIstant	The grid current is too high, and has cause unrecoverable fault	

ID75	unrecoverEEPROM_W	The EEPROM is unrecoverable	
ID76	unrecoverEEPROM_R	The EEPROM is unrecoverable	
ID77	unrecoverRelayFail	Relay has happen permanent fault	
ID81	Over temperature	Internal temperature is too high.	<p>1. Please make sure ME 3000SP in installed in a place without direct sunlight/other heat source.</p> <p>2. Please make sure the inverter is vertically installed &amp; the ambient temperature is less than the temperature upper limit of ME3000SP</p>
ID82	Over frequency	AC frequency is too high	
ID85	Battery voltage is low	Low battery warning	<p>This is only an indication of low battery voltage (normally means low battery SOC)</p> <p>ME3000SP won't discharge the battery to prevent over-discharge to ensure long battery cycle life. ME3000SP will charge the battery to a certain level before discharging the battery.</p>
ID94	Software version is not consistent		Contact technical support to upgrade software.
ID95	CommEEPROMFault	The Communication board EEPROM is fault	<p>ID95-ID96 are internal faults of ME3000SP, turn OFF the "DC &amp; AC switch", wait for 5 minutes, then turn ON the "DC switch" and turn ON the "AC switch". Check whether the fault is rectified. If no, please contact technical support.</p>
ID96	RTCFault	RTC clock chip is fault	
ID97	InValidCountry	Invalid Country	
ID98	SDfault	The SD card is fault	Please replace the SD card.
ID100	BatOCD	Battery over current discharging protect	<p>ID100-ID103 is battery fault. If this fault occurs occasionally, wait few minutes to see whether the fault is rectified.</p> <p>If this fault occurs frequently, please contact technical support.</p>
ID101	BatSCD	Discharging short circuit protect	
ID102	BatOV	Battery high voltage protect	
ID103	BatUV	Battery low voltage protect	
ID104	BatOTD	Battery discharging high temperature protect	<p>Battery fault. Check whether the air condition around the equipment is good. Or set the "max discharging &amp; charging current" a little lower to check whether the fault is rectified. If the fault occurs frequently, please contact technical support.</p>
ID105	BatOTC	Battery charging high temperature protect	
ID106	BatUTD	Battery discharging Low temperature protect	<p>Id106-id107 is battery fault. Increase the temperature of the battery. If the fault occurs frequently, please contact technical support.</p>
ID107	BatUTC	Battery charging Low temperature protect	