SolarEdge ONE Controller

For C&I

CLC1



An on-site manager that integrates local devices for maximized energy optimization

- Optimizing the use of locally generated energy to reduce electricity costs, enabled by the SolarEdge ONE for C&I optimization platform¹
- Local communication gateway that connects the site's energy assets, including SolarEdge PV inverters, batteries, meters, and more
- Interfaces with selected third-party environmental sensors to enable in-depth analysis for O&M and energy optimization
- PPC platform, designed to comply with grid regulations to enable safe, reliable electricity generation
- Acts as a cyber secured gateway for external communications designed to protect against unauthorized access
- Includes extended local data retention in case of cloud connectivity interruptions
- Supports secure over-the-air firmware upgrades

¹ Use of all software components, if any, shall be governed by and subject to the SolarEdge Software License Terms and Conditions.

/ SolarEdge ONE Controller for C&I

CLC1

		CLC1	Units	
COMMUNICATION I/O				
USB	2 x USB 2.0 ports and 1 x USB 3.0 port, type-A connectors			
RS485	2 x isolated, terminal-block connectors			
CAN Bus	1 x isolated, terminal-block connector			
Digital I/O	4 x digital outputs + 4 x digital inputs Isolated, 24 V compliant with EN 61131-2, terminal-block connector			
LAN	2 x RJ45 connectors 2 x 1000 Mbps			
Wireless	802.11ax WiFi and Bluetooth 5.3 BLE 2 x 2.4 GHz / 5 GHz antenna sockets (for rubber duck antenna)			
Security	TPM 2.0			
PROTOCOL				
Over RS485	Modbus RTU			
Over LAN	TCP/IP, Modbus TCP			
ELECTRICAL				
Power Supply	Included, 100 – 240 Vac, 50 / 60 Hz, EU / UK / US / AUS Interchangeable			
Supply Voltage	Unregulated 8 – 36		V	
Typical Power Consumption	Linux Idle	Current	200	mA
		Power	2.4	W
	CPU, memory stress test, and connectivity activity	Current	450	mA
		Power	5.4	W
MECHANICAL				
Dimensions	132 x 84 x 25		mm	
Weight	550		g	
Button	1 x Power			
LED	3 x Power, Local, and Cloud Communication indicators			
Cooling	Passive cooling, fanless design			
ENVIRONMENTAL				
Operation Temperature	-40 to 80		°C	
IP Rating	IP30			
Relative Humidity	Commercial: 0 to 60; Industrial: -40 to 80		°C	
Maximum Altitude	3000		m	
STANDARD COMPLIANCE				
Safety	US/Canada	UL 62368-1:2019; CSA-C22.2 No.62368-1:19		
	EU/UK	EN 62368-1: A11:2020; IEC 62368-1:2018 (Ed.3)		
EMC	US/Canada	FCC 47CFR Part 15: 2021, Subpart B, Class B; ICES-003: 2020 Issue 7, Class B		
	EU/UK	EN 55032: 2015 + A1(20) + A11(20), Class B; EN 55035: 2017 + A11(20); EN 61000-3-2: 2014; EN 61000-3-3: 2013; EN IEC 61000-6-2: 2019; EN IEC 61000-6-3: 2021 Class B; EN 301 489-1: V2.2.3: 2019, Class B; EN 301 489-17: V3.2.4: 2020, Class B; EN 301 489-52: V1.2.1: 2021		
RED (RF) WiFi / BT	US/Canada	FCC ID: PD9AX210NG		
	EU/UK	EN 300 328 v2.2.2 (WLAN & BT); EN 301 893 v2.1.1; EN 300 440 v2.2.1; EN 303 687 V1.0.0		
INSTALLATION SPECIFICATIONS				
Mounting	DIN Rail or Wall Mount			
Kit Content	Power supply unit, 2 x WiFi / BT rubber duck antennas 2 x 11-pin dual-row plug Wall mounting bracket DIN-rail mounting kit			
Compatible Meters	IMT SI RS485tc 2T MB; IMT SI RS485tc 2T v MB; IMT SI RS485TC 3T MB; IMT SI RS485 TC T MB; IMT SI RS485 T TM MB; IMT TX RS485			
Compatible Sensors	Kipp and Zonen Dust IQ; SMP Series Devices; Kipp and Zonen RT1; Kipp and Zonen WS50pv; Lufft Intelligent Weather Station; Thies Klima Sensor			
APPLICATIONS				
Power Control	Export / Import Limit			

/ SolarEdge ONE Controller for C&I

CLC1

Connection Scenarios

The following diagram shows a typical system architecture that includes the cloud-based SolarEdge ONE for C&I optimization platform, the local SolarEdge ONE Controller, and the connection with additional devices, including SolarEdge inverters and commercial storage solutions, as well as third-party energy meters and sensors.

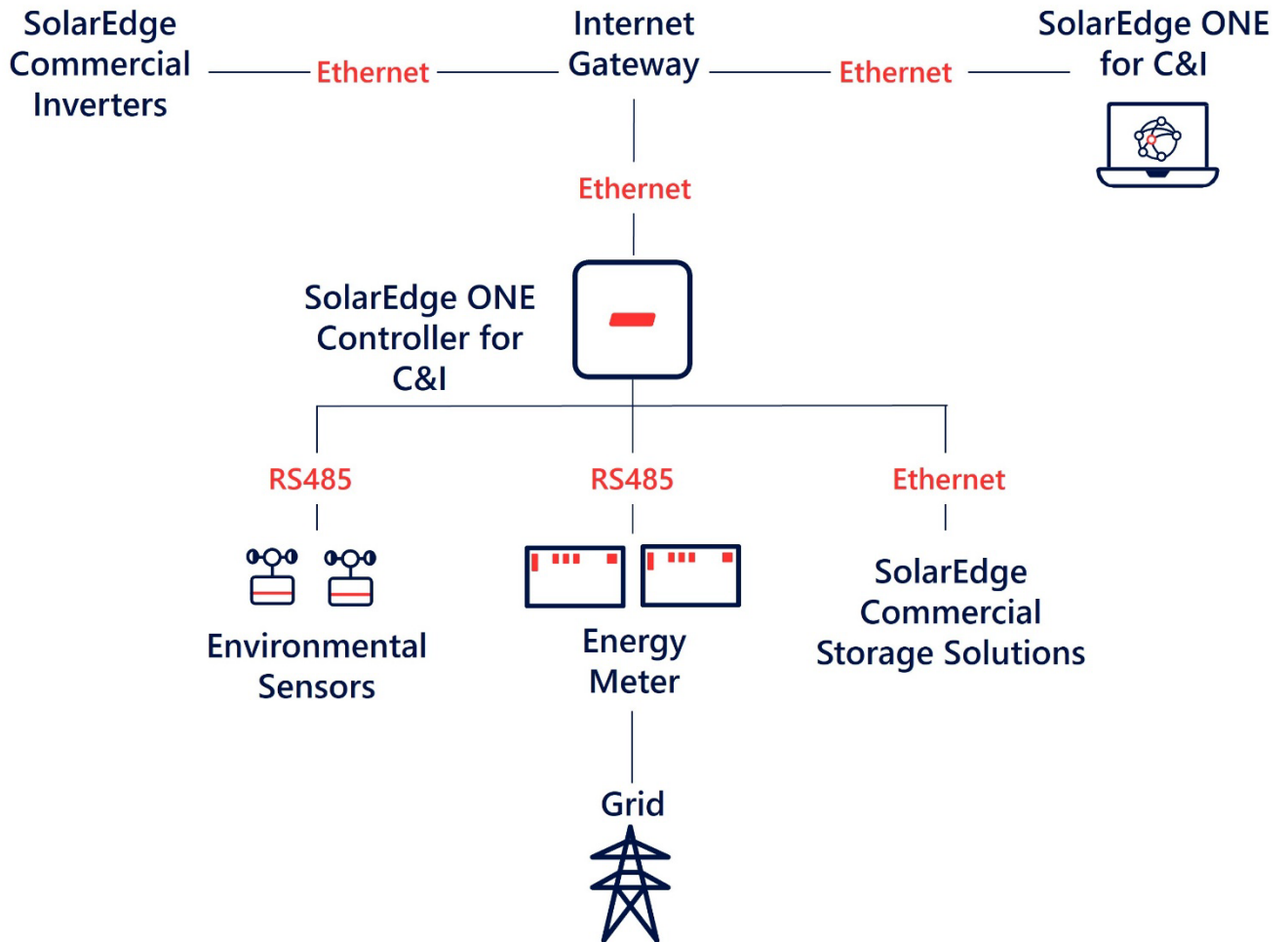

SolarEdge is a global leader in smart energy technology. By leveraging world-class engineering capabilities and with a relentless focus on innovation, SolarEdge creates smart energy solutions that power our lives and drive future progress.

SolarEdge developed an intelligent inverter solution that changed the way power is harvested and managed in photovoltaic (PV) systems. The SolarEdge DC optimized inverter maximizes power generation while lowering the cost of energy produced by the PV system.

Continuing to advance smart energy, SolarEdge addresses a broad range of energy market segments through its PV, storage, EV charging, UPS, and grid services solutions.

-  SolarEdge
-  @SolarEdgePV
-  @SolarEdgePV
-  SolarEdgePV
-  SolarEdge
-  www.solaredge.com/corporate/contact

solaredge.com

© SolarEdge Technologies, Ltd. All rights reserved. SOLAREEDGE, the SolarEdge logo, OPTIMIZED BY SOLAREEDGE are trademarks or registered trademarks of SolarEdge Technologies, Inc. All other trademarks mentioned herein are trademarks of their respective owners. Date: May 2025, DS-000221-ENG
Subject to change without notice.

Cautionary Note Regarding Market Data and Industry Forecasts: This brochure may contain market data and industry forecasts from certain third-party sources. This information is based on industry surveys and the preparer's expertise in the industry and there can be no assurance that any such market data is accurate or that any such industry forecasts will be achieved. Although we have not independently verified the accuracy of such market data and industry forecasts, we believe that the market data is reliable and that the industry forecasts are reasonable.

