



SolarEdge Installation Guide

for Three Phase Inverters

Version 1.5



About This Guide

This user guide is intended for Photovoltaic (PV) system owners, installers, technicians, maintainers and integrators who are authorized to install and connect a SolarEdge power harvesting system.

This guide describes the process of installing SolarEdge power optimizers and SolarEdge Three Phase Inverters. This guide does not describe how to install the PV modules. The inverter models covered in this guide are: SE8k, SE10k and, SE12k. The power optimizer models covered in the guide are OP250-LV, OP300-MV, OP400-MV, PB250-AOB, PB350-AOB, PB250-TFI and PB350-TFI.

The guide includes the following chapters:

- **Chapter 1, Introducing the SolarEdge Power Harvesting System**, page 9, introduces the components of the SolarEdge power harvesting solution.
- **Chapter 2, Installing the Power Optimizers**, page 15, describes how to install the SolarEdge power optimizers.
- **Chapter 3, Installing the Inverter**, page 25, describes the process of installing and connecting a SolarEdge Three Phase Inverter.
- **Chapter 4, Commissioning the Installation**, page 37, describes how to activate the system, commission the power optimizers and verify the proper functioning of the system.
- **Chapter 5, Replacing and Adding System Components**, page 46, describes how to replace or add various SolarEdge system components after the initial installation.
- **Chapter 6, Setting Up Communication**, page 50, describes how to install and set up communication between the inverter and the SolarEdge Monitoring Server.
- **Chapter 7, Inverter User Interface**, page 61, describes how to configure the inverter and how to identify its status.

- **Appendix A, Errors and Troubleshooting**, page 75, lists the error messages that may appear on the inverter’s LCD panel, describes their meaning and describes how to troubleshoot each one.
- **Appendix B, Technical Specifications**, page 81, provides the technical specifications of the SolarEdge system components.
- **Appendix C, Power Optimizer Mechanical Specifications**, page 87, presents the mechanical specifications for the SolarEdge power optimizers.

Additional Documentation

The following describes where additional information and manuals can be accessed. For further information, datasheets and the most up-to-date certifications for various products in different countries, please visit the SolarEdge web site: www.solaredge.com

The following additional manuals can be found on the site:

- SolarEdge Monitoring Portal User Guide
- SolarEdge Configuration Tool Software Guide
- SolarEdge Recommended AC Wiring Application Note

Important Notice

Copyright © SolarEdge Inc. All rights reserved.

No part of this document may be reproduced, stored in a retrieval system or transmitted, in any form or by any means, electronic, mechanical, photographic, magnetic or otherwise, without the prior written permission of SolarEdge Inc.

This document is solely for the use of SolarEdge customers and employees.

The material furnished in this document is believed to be accurate and reliable. However, SolarEdge assumes no responsibility for the use of this material. SolarEdge reserves the right to make changes to the material at any time and without notice. You may refer to the SolarEdge web site (www.solaredge.com) for the most updated version.

All company and brand products and service names are trademarks or registered trademarks of their respective holders.

Exclusion of Liability

The general terms and conditions of delivery of SolarEdge shall apply.

The content of these documents is continually reviewed and amended, where necessary. However, discrepancies cannot be excluded. No guarantee is made for the completeness of these documents.



Table of Contents

Handling and Safety Instructions	6
Support and Contact Information	8
Chapter 1, Introducing the SolarEdge Power Harvesting System.....	9
What is the SolarEdge Power Harvesting Solution?	9
SolarEdge Power Optimizer	9
Three Phase Inverter	10
SolarEdge Monitoring Portal	11
Installation Workflow	12
Transport and Storage	13
Three Phase Inverter Transport.....	13
Three Phase Inverter Storage	13
Equipment List	13
Chapter 2, Installing the Power Optimizers.....	15
Applicable Notes and Warnings.....	15
Step 1, Mounting the Power Optimizers	17
Step 2, Connecting Each PV Module to a Power Optimizer	18
OP250-LV, OP300-MV and OP400-MV	18
PB250-AOB and PB350-AOB	19
PB250-TFI and PB350-TFI	20
Connecting Power Optimizers	21
Step 3, Connecting Power Optimizers in Strings.....	22
Constructing Strings	22
Verifying Proper Power Optimizer Connection.....	23
Chapter 3, Installing the Inverter.....	25
Identifying the Inverter.....	25
Selecting the Mounting Location	26
Chassis Clearance	26
Mounting the Inverter.....	27
Connecting the Inverter.....	29
Inverter Connection Overview.....	29
Connecting the Three Phase Inverter	30
Completing the Three Phase Inverter Installation.....	34
Residual Current Device.....	36

Chapter 4, Commissioning the Installation	37
Commissioning – Workflow	37
Step 1, Activating the System.....	38
Step 2, Pairing Power Optimizers to the Inverter	39
Step 3, Verifying Proper Operation	41
Step 4, Reporting and Monitoring Installation Data	42
Chapter 5, Replacing and Adding System Components	46
Modifying an Existing Installation.....	46
Replacing the Fans	48
Chapter 6, Setting Up Communication.....	50
Communication Dataflow	50
Communication Types	50
Creating an RS232 (UART) Connection	52
Creating an Ethernet (LAN) Connection	53
Creating an RS485 Bus Connection.....	56
Verifying the Connection.....	59
Troubleshooting Communication	60
Chapter 7, Inverter User Interface.....	61
Inverter LCD Panel and LEDs.....	61
Inverter LCD Panel and User Buttons	62
Configuring the Inverter Using the LCD Panel and User Buttons	67
Inverter Configuration Menu Options	71
Configuring the Inverter Using the SolarEdge Configuration Tool	74
Appendix A, Errors and Troubleshooting.....	75
Appendix B, Technical Specifications	81
Three Phase Inverter.....	81
OP250-LV, OP300-MV and OP400-MV.....	83
PB250-AOB and PB350-AOB	84
PB250-TFI and PB350-TFI Power Optimizer	85
Appendix C, Power Optimizer Mechanical Specifications	87
OP250-LV, OP300-MV, OP400-MV Power Optimizers.....	88
PB250-AOB and PB350-AOB Power Optimizers.....	89
PB250-TFI and PB350-TFI Power Optimizer	90



Handling and Safety Instructions

During installation, testing and inspection adherence to the following handling and safety instructions is mandatory.

Safety Symbols

The following safety symbols are used throughout this document. Familiarize yourself with the symbols and their meaning before installing or operating this instrument.



WARNING!

Denotes a hazard. It calls attention to a procedure that, if not correctly performed or adhered to, could result in **injury or loss of life**. Do not proceed beyond a warning note until the indicated conditions are fully understood and met.



CAUTION:

Denotes a hazard. It calls attention to a procedure that, if not correctly performed or adhered to, could result in **damage or destruction of the instrument**. Do not proceed beyond a caution sign until the indicated conditions are fully understood and met.



NOTE:

Denotes additional information about the current subject.



IMPORTANT SAFETY FEATURE:

Denotes information about safety issues.

Instructions

**WARNING!**

Do not remove the inverter cover before five minutes have elapsed after disconnecting all sources of power. Only use lockable connectors for DC input. Otherwise, there is a risk of electric shock from energy stored in the capacitor.

**WARNING!**

Before operating the Three Phase Inverter, ensure that the power cable and wall outlet have been grounded properly.

**WARNING!**

The cover must only be opened after shutting off the AC power, disconnecting the DC cables and waiting five minutes.

**WARNING!**

Repairs or testing under power must only be performed by qualified SolarEdge technicians who are familiar with and qualified to work with this Three Phase Inverter.

**WARNING!**

This unit is not intended to be opened by a user. It must only be opened by a qualified technician for installation and maintenance purposes.

**CAUTION:**

This unit must be operated under the specified operating specifications, as described in the technical specification document.



Support and Contact Information

If you have technical problems concerning our products, please contact us:

USA & Worldwide Support Line: +1.650.319.8843

Germany: +49.89.4161703-30

France: +33.(0)970.465.662

Israel: +972.73.2403118

Fax: +972.73.2403117

Email to: support@solaredge.com

Before contact, please gather the following information:

- Inverter and power optimizer type.
- Serial number of the inverter and the power optimizer in question.
- The error indicated on the inverter screen or on the SolarEdge Monitoring Portal.
- System configuration information, including the type and number of modules connected and the number and length of strings.
- The communication method to the SolarEdge server.

The **Support**  option on the top right of the SolarEdge Configuration Tool's main window can be used to automatically collect all relevant information to be sent to SolarEdge Professional Services for support. This option is described in detail in the *SolarEdge Configuration Tool Software Guide*.



Chapter 1

Introducing the SolarEdge Power Harvesting System

What is the SolarEdge Power Harvesting Solution?

The SolarEdge power harvesting solution maximizes the power output from any type of solar PV installation while reducing the average cost per watt. The sections below describe each of the system's components.

SolarEdge Power Optimizer

SolarEdge power optimizers can be connected to existing PV modules in order to maximize power harvesting by locally performing Maximum Power Point Tracking (MPPT) at the PV module level.

The power optimizers keep the string voltage fixed, regardless of the length of the string and of the environmental conditions. Each SolarEdge power optimizer directly transmits performance data from every PV module over the power line.

Three types of power optimizers are provided by SolarEdge, as follows:

- **Module Add-On Solution**, connected during installation to one PV module. P/N: OP250-LV, OP300-MV and OP400-MV, PB250-AOB, PB350-AOB.
- **Thin Film Solution (TFI)**, connected during installation to between one and four PV modules. P/N: PB250-TFI and PB350-TFI.
- **Module Embedded Solution (CSI)**, is supplied embedded into a PV module.

You may refer to the SolarEdge power optimizer datasheets in order to determine which power optimizer is most suitable for your requirements.

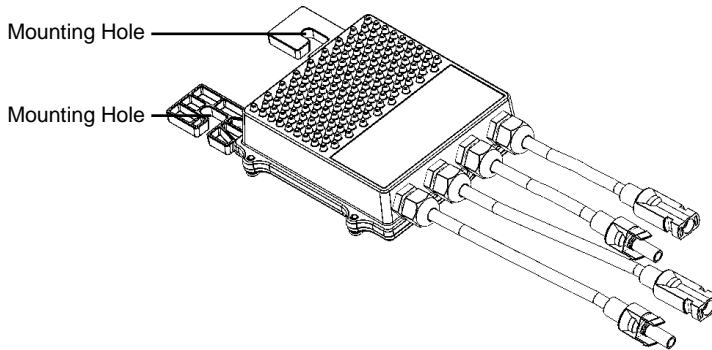

Figure 1: Add-On Box Solution

Three Phase Inverter

The Three Phase Inverter efficiently converts DC power received from the PV modules into AC power that can be fed into the main circuit board of the site and from there to the grid. The inverter also receives the monitoring data from each power optimizer and transmits it to a central server (called the Monitoring Server) through an Ethernet network to an external modem connection.

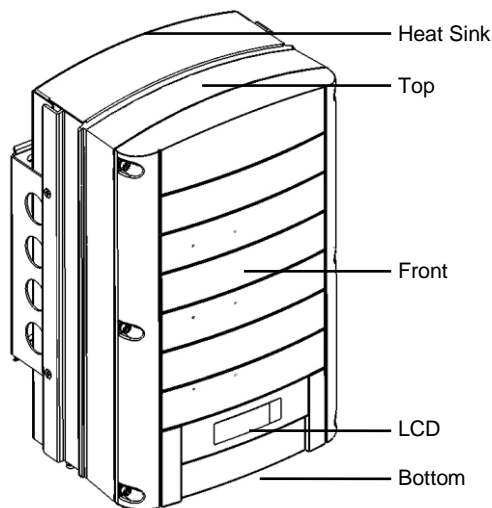

Figure 2: Three Phase Inverter

Three Phase Inverter Package Contents

The following lists the contents of the Three Phase Inverter installation package:

- One SolarEdge Three Phase Inverter.
- One wall-mounting bracket.
- Two flat head screws for fastening the inverter to the wall-mounting bracket.
- User Guide.
- Warranty Card.
- CD containing literature (manual, application notes and data sheets) and software.

SolarEdge Monitoring Portal

The SolarEdge Monitoring Portal enables you to monitor the technical and financial performance of one or more SolarEdge Photovoltaic sites. It provides information about present and past performance of each PV module individually and about the system as a whole.

**NOTE:**

You may refer to the *SolarEdge Monitoring Portal User Guide* for more information about this option.

Installation Workflow

The following provides an overview of the workflow for installing and setting up a new SolarEdge site. Most of these procedures can also be used for adding components to an existing SolarEdge site.

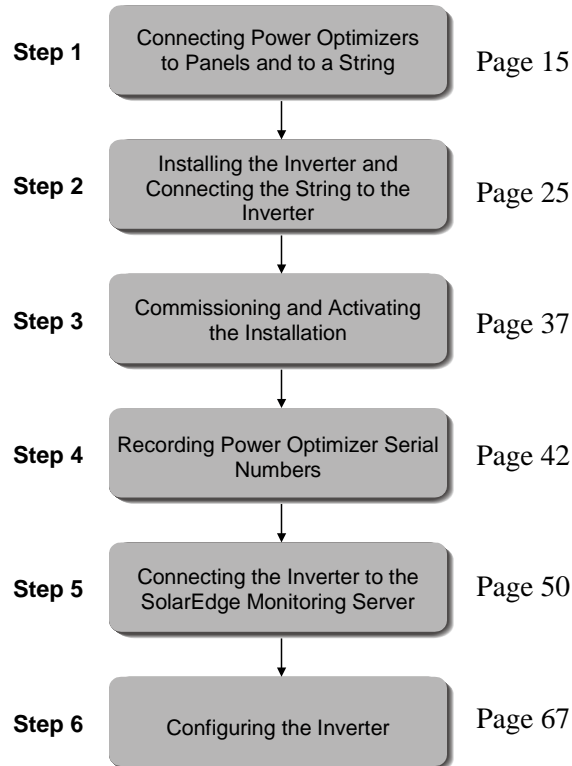

Transport and Storage

Three Phase Inverter Transport

The Three Phase Inverter should be transported in its original packaging, facing up and without exposing the Three Phase Inverter to unnecessary shocks. If the original package is no longer available, a similar box can be used which can withstand the weight of the Three Phase Inverter (25 kg), has a handle system and can be closed fully.

Three Phase Inverter Storage

Store the Three Phase Inverter in a dry place where ambient temperatures are always between -25°C and +60°C.

Equipment List

Standard tools can be used during the installation of the SolarEdge system. The following is a recommendation of the equipment to be used when installing a SolarEdge system:

- Allen screwdriver for M6 and M5 screw types.
- Flat Head screwdriver.
- Electrical screwdriver (tester).
- Drilling machine and bits suitable for a wall or pole, where the inverter mounting bracket is installed.
- Suitable screws for attaching the inverter mounting bracket to a wall.
- M8 screws for attaching the power optimizer to the racking.
- Wire cutters.
- Wire strippers.
- Voltmeter.

For installing the communication option, you may also need the following:

- For Ethernet:
 - RJ45 connectors
 - CAT5 twisted pair Ethernet cable
 - RJ45 crimping tool
- For RS485:
 - Four- or six-wire twisted pair telephone cable
 - RJ11 six-pin connector (also known as RJ25)
 - RJ11 crimping tool

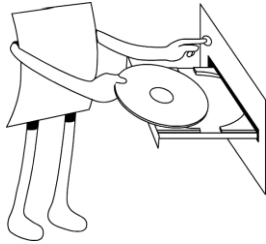

Chapter 2

Installing the Power Optimizers

Applicable Notes and Warnings

The following notes and warnings apply when installing the SolarEdge power optimizers:

**NOTE:**

The power optimizer is waterproof and has no need for shelter. The power optimizer can be placed in any orientation, meaning there is no up side.

**NOTE:**

The power optimizer should be mounted in a location that is either ventilated or that has a free space of air around it for heat dissipation.

**NOTE:**

Mounting brackets are suited to either a flat surface or a pole and can be attached to any surface texture.

**CAUTION:**

If installing directly on the module or module frame, first consult the module manufacturer for guidance regarding location and the impact on the module warranty.

**IMPORTANT SAFETY FEATURE:**

PV modules with SolarEdge power optimizers are safe. They only carry a low safety voltage before the Three Phase Inverter is turned on.

**IMPORTANT SAFETY FEATURE:**

As long as the power optimizers are unconnected to the inverter and the inverter is OFF, the power optimizers will output a safe 1V voltage during installation.

**WARNING!**

Before performing this step, turn OFF the Three Phase Inverter by turning off the ON/OFF switch at the bottom of the inverter and the DC switch of the main circuit board. All inverters in an installation site should be switched OFF in this manner. This step is required to verify that the power optimizers will output a safe 1V voltage during installation.

**CAUTION:**

The module connectors must be mechanical compatible to the power optimizers. Otherwise, the installed SolarEdge system may be unsafe or may cause functional problems, such as ground faults, which can cause the inverter to shut down. The usage of mechanically incompatible connectors is not covered by the SolarEdge warranty.

SolarEdge power optimizers and inverters use connectors from the following manufacturers:

- Multi Contact MC4
- Amphenol H4
- Lumberg LC4
- Tyco keyed connector
- Huber suhner Raddox

The following must be done in order to ensure mechanical compatibility between SolarEdge power optimizers and the modules to which they are connected:

- Use identical connectors from the same manufacturer and type on both the power optimizers and on the modules.
or
- Verify that the connectors are compatible in the following ways:
 - The connector manufacturer should explicitly verify compatibility with the SolarEdge connector.
 - A third-party test report must be performed by one of the listed external labs (TUV, VDE, Bureau Veritas UL, CSA, InterTek), who will verify the compatibility of the connectors.

Step 1, Mounting the Power Optimizers

**NOTE:**

If you are installing modules with embedded power optimizers, then skip to *Step 3, Connecting Power Optimizers in Strings* on page 22.

- Determine the mounting location of each power optimizer. The power optimizer should be mounted in a place where it can be mounted securely using both mounting holes. It must also be located near enough so that the power optimizer can connect to a single PV module (for the OP250-LV, OP300-MV, OP400-MV, PB250-AOB and PB350-AOB models) or the power optimizer can connect to up to four PV modules for the PB250-TFI and PB350-TFI models, per your plan. Mark all mounting hole locations.
- Each power optimizer must be attached to the rack using both mounting holes.
- Drill the holes.

**CAUTION:**

Do not drill through the power optimizer or through the mounting holes. The vibrations created by the drill can damage the power optimizer.

- Mount one power optimizer at each location using M8 screws and washers.
- Verify that the power optimizer is securely attached.

Step 2, Connecting Each PV Module to a Power Optimizer

OP250-LV, OP300-MV and OP400-MV

These power optimizers connect to a single PV module via its two inputs (a plus and a minus).

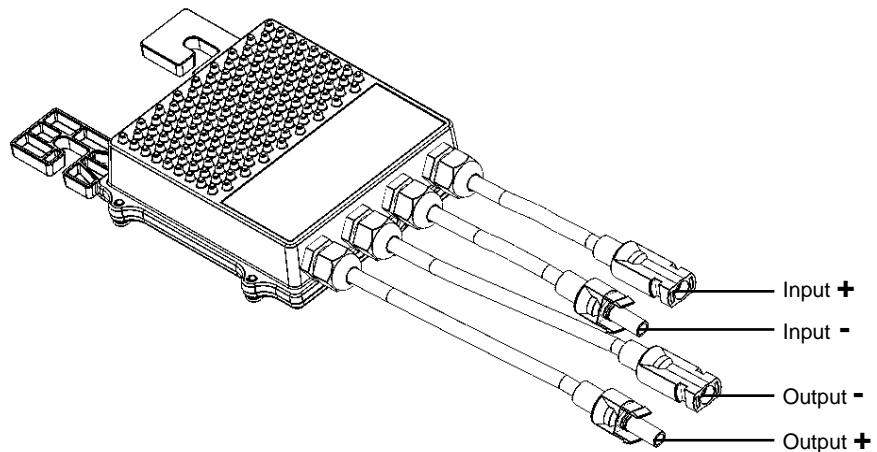

Figure 3: OP250-LV, OP300-MV and OP400-MV

PB250-AOB and PB350-AOB

These power optimizers connect to a single PV module via its two inputs (a plus and a minus).

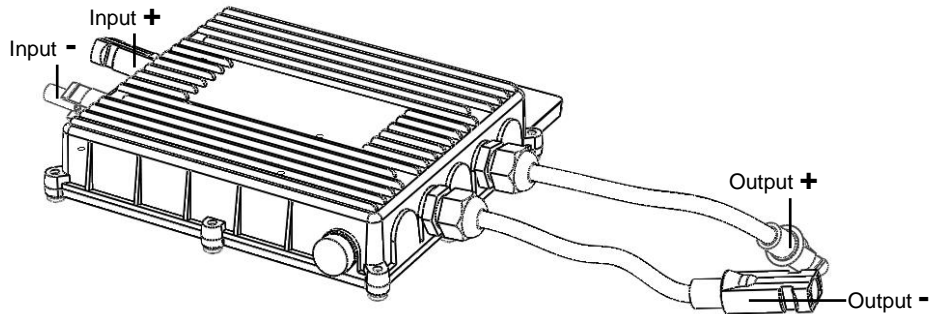

Figure 4: PB250-AOB and PB350-AOB

The following shows the required clearance around the power optimizer.

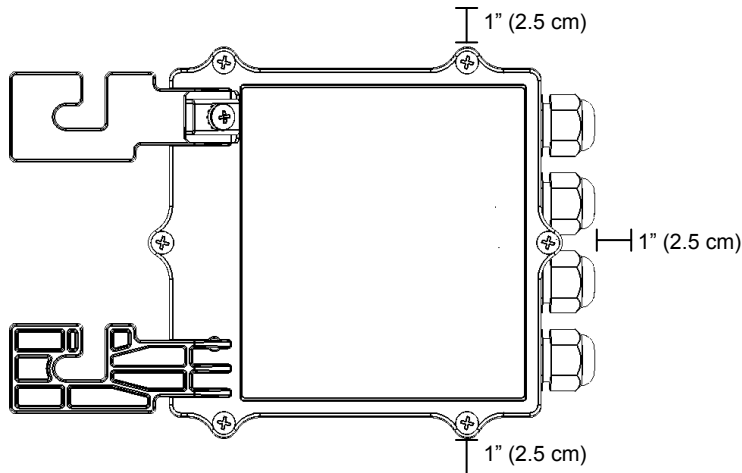

Figure 5: Clearance

The following shows the required clearance on the top and bottom of the power optimizer.

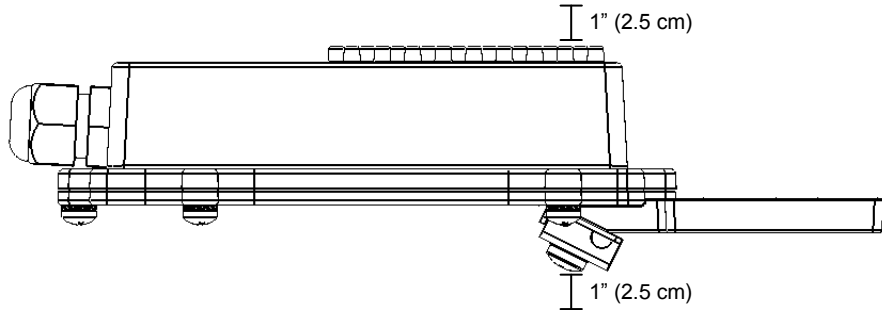

Figure 6: Clearance – Side View

PB250-TFI and PB350-TFI

These power optimizers connect to up to four PV modules via its inputs. These power optimizers have four pairs of inputs (each pair comprises one Plus (+) and one Minus (-) connector) and two outputs (one Plus (+) and one Minus (-)), as shown below.

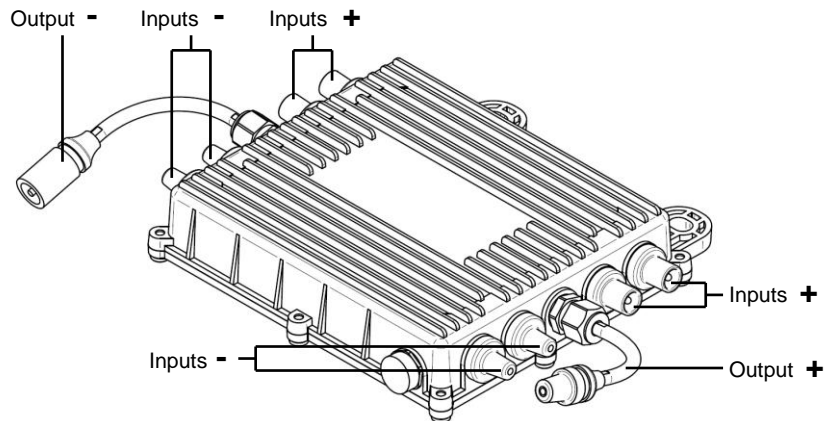

Figure 7: PB250-TFI and PB350-TFI

Connecting Power Optimizers

► **To connect these power optimizers to the PV modules:**

**WARNING!**

Verify that you have identified the inputs and outputs correctly. Do not connect PV modules to power optimizer outputs.

**NOTE:**

The power optimizer has reverse polarity protection. Even so, you must still verify the correct polarity by checking the PV module's polarity with a voltmeter. Some module manufacturers may use connector polarity that is different from that used by SolarEdge power optimizer inputs.

- The input connectors are shown in the figures above. The output connectors are in the middle of each side.
- The pairs of connectors on the power optimizers are provided sealed.
- If you connect less than four modules to a PB250-TFI or PB350-TFI power optimizer, then you can leave the unused connectors sealed (as is) instead of plugging them.
- The Plus (+) and Minus (-) input connectors on the PB250-TFI and the PB350-TFI power optimizers are not specifically paired, meaning that you can connect a PV module to any Plus (+) input connector and Minus (-) input connector.

Step 3, Connecting Power Optimizers in Strings

Power optimizers must be connected in series in order to construct strings.



IMPORTANT NOTE:

SolarEdge power optimizers are energized by the PV modules to which they are connected. String length must not be less than 16 power optimizers or the entire string may shut down. (Please refer to the power optimizer datasheets for the exact minimum and maximum number of power optimizers permitted in a string.)



NOTE:

Completely shaded PV modules may cause the affected power optimizers to temporarily shut down. This will not affect the performance of the other power optimizers in the string, as long as the minimum string length requirement is met when taking into account the lighted panels only. In favorable conditions, if there is a chance that so many PV modules will be in complete shade such that less than 16 will remain, then add more PV modules.



IMPORTANT NOTE:

Be sure to record power optimizer serial numbers during their installation, as this information may be required later for troubleshooting.

The SolarEdge Monitoring Portal can be used to access SolarEdge site information, as described in the *Step 4, Reporting and Monitoring Installation Data* section on page 42.

Constructing Strings

► To connect power optimizers in a string:



IMPORTANT SAFETY FEATURE:

As long as the power optimizers are unconnected to the inverter and the inverter is OFF, the power optimizers will output a safe 1V voltage during installation.

- The full string can either be directly connected to the inverter or connected in parallel to another strings and then together they are connected to the inverter.
- You can construct and connect in parallel strings of unequal length, meaning the number of power optimizers in each string does not have to be the same.

- The power optimizer output cables are labeled + and – .
- Connect the Plus (+) connector of the output wire of the first power optimizer in the string to the Minus (-) connector of the second power optimizer in the string. Repeat this step for each power optimizer in the string. This procedure is similar to the standard procedure for connecting PV modules.

**WARNING!**

Make sure that the Plus (+) and the Minus (-) connector cables are firmly and totally inserted.

**IMPORTANT NOTE:**

Be sure to record power optimizer serial numbers during their installation, as this information may be required later for troubleshooting.

The SolarEdge Monitoring Portal can be used to access SolarEdge site information, as described in the *Step 4, Reporting and Monitoring Installation Data* section on page 42.

Verifying Proper Power Optimizer Connection

► To verify proper power optimizer connection:

- Make sure the PV modules are exposed to sunlight during this process. Otherwise, the power optimizers may not be on.
- Verify each string individually before connecting it to the other strings or to the inverter.
- Each power optimizer connected to a PV module initially produces a safe voltage of 1 V. A string with properly connected power optimizers should produce 1 V per power optimizer in the string. For example, if 10 power optimizers are connected in a string, then 10 V should be produced. Use a voltmeter with at least 0.1V measurement accuracy to verify that the total voltage produced is in accordance with the number of power optimizers in the string.
 - If 0 V is measured for the string, check for a disconnection of the outputs of one of the power optimizers.

- If the voltage is lower than the quantity of power optimizers (for example, 9 V when 10 power optimizers are connected), verify whether one or more of the power optimizers are not connected, meaning they were skipped during the string connection process. If they are all connected, verify whether one or more of the PV modules is not connected properly to its power optimizer.
- If the voltage is too high, then apply the CAUTION below.

**CAUTION:**

If the measured voltage is too high, the installation may not have a safe low voltage. **PROCEED WITH CARE!!**

Please note that a deviation of up to 2V for a full string is considered normal.

A voltage that is higher than the quantity of power optimizers may be caused by one of the following reasons:

- An extra power optimizer is connected in the string.
- The output of a PV module may be connected in the string instead of the output of a Optimizer.
- A malfunction of one of the power optimizers.
- Perform the following if the total string voltage is too high:
 - Verify that only power optimizers are connected in the string and that no PV module outputs are connected without a power optimizer.
 - Disconnect the wires that connect the power optimizers in the string.
 - Measure that there is 1V safety voltage for each individual power optimizer in order to locate the power optimizer that does not output the proper voltage.
 - If a malfunctioning power optimizer is located, check its connections, polarity, module and voltage.
 - If a malfunction cannot be bypassed or resolved, skip the malfunctioning power optimizer, thus connecting a shorter string.
 - Do not continue before finding the problem and removing the malfunctioning power optimizer.

**IMPORTANT SAFETY FEATURE:**

After a PV module is connected to the power optimizer, the power optimizer outputs a safe voltage of 1 V. We suggest verifying this output for the first few power optimizers that you connect in order to verify their proper connection. Take note that if you use a tracker, the power optimizer will turn ON only if the tracker is tracking the sun and at least 2 W of power are provided by the PV module.

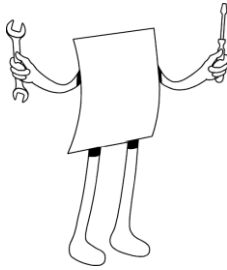

Chapter 3

Installing the Inverter

The Three Phase Inverter can be installed either before or after the PV modules and power optimizers have been installed.

Identifying the Inverter

Refer to the sticker on the side of the inverter that specifies its **Serial #** and its **Electrical Ratings** including its **Max Output Power**.

solar _{edge} SE12k Photovoltaic Three-Phase Power Inverter		
Electrical Ratings		
DC	Max. Operating Voltage	950V
DC	Operating Voltage Range	680-950V
DC	Max. Input Current	22.5A
AC	Nominal Operating Voltage	$230V_{L-N} / 400V_{L-L}$
AC	Nominal Operating Frequency	50Hz
AC	Nominal Output Power	12000W
AC	Max. Output Power	12000W
AC	Max. Power Current	$19 I_{ARMS}$
	Operating Temp. Range	$-20^{\circ}+40^{\circ}C$
	Enclosure	IP65
	Safety Standard	IEC 62109

The inverter serial number is also indicated on the enclosed warranty card. Please provide the serial number when contacting the SolarEdge support line. The serial number is also required when requesting to open a new site in the SolarEdge Monitoring Portal.

Selecting the Mounting Location

This process involves attaching the inverter mounting bracket to a wall or pole and then mounting the Three Phase Inverter onto it.

Chassis Clearance

The heat dissipation solution requires the following clearance areas between the Three Phase Inverter chassis and all types of obstructions, such as wires and walls:

- 8" (20 cm) to the top and bottom of the chassis
- 4" (10 cm) to the right and left of the chassis



NOTE:

If more than one Three Phase Inverters are installed side by side, the distances between them must exceed 4" (10 cm).

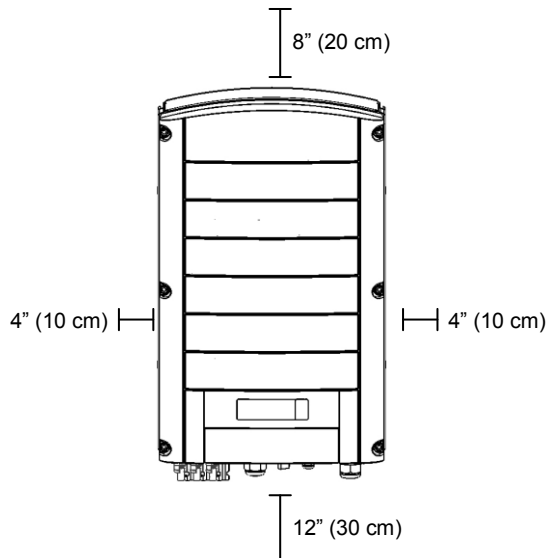

Figure 8: Chassis Clearance

Mounting the Inverter

**CAUTION:**

Make sure that you have read the previous sections in this chapter before starting the mounting process that is described below.

The Three Phase Inverter installation package provides the Three Phase Inverter and the mounting bracket that is required to connect it to the wall. Standard tools (not provided) can be used during its installation.

► **To mount the Three Phase Inverter:**

- 1 Attach the provided bracket to a wall or pole, as follows:
 - Ensure that the U-shaped part of the bracket is positioned on the top, as shown below:

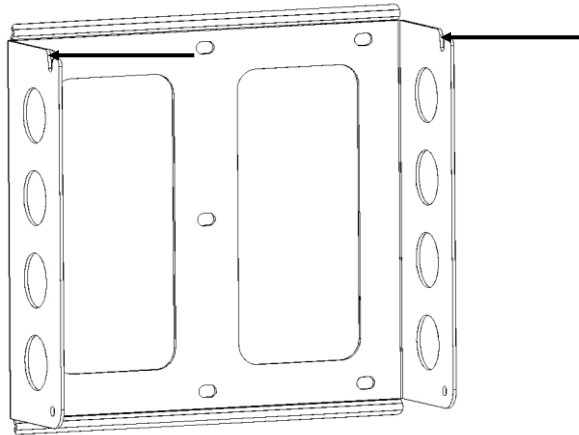

Figure 9: Positioning the U-shaped Part of the Bracket

- When mounting on a wall, bolt the four outer-most holes of the bracket.
Other holes may be used to stabilize the bracket or when the outer-most holes cannot be used.
 - When mounting on a pole, bolt the suitable inner holes of the bracket.
- 2 Verify that the bracket is firmly attached to the wall or pole.

- 3 Hang the inverter on the bracket using the screws on the inverter's top, as shown below:

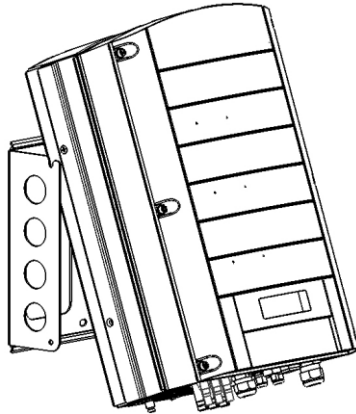

Figure 10: Hanging the Inverter on the Bracket



CAUTION:

Do not rest the connectors at the bottom of the inverter on the ground at any time, as it may damage them. If you need to rest the chassis on the ground, lay it on its back, front or side, not on its bottom.

- 4 Let the chassis lay flat against the wall or pole. Then, screw two screws into the right and left sides of the bottom of the bracket. The screws go through the outer heat sink on either side into the bracket, as shown below:

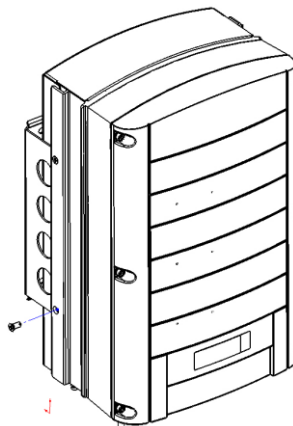

Figure 11: Inserting the Screws into the Bottom Heat Sink

Connecting the Inverter

Inverter Connection Overview

The SolarEdge inverter can be configured in the field for an AC grid, including AC voltage and frequency. If the inverter's default settings are not suited to the country of the installation site, then please refer to page 71 for a description of how to configure the inverter for the required country.

With the SolarEdge Configuration Tool, you can configure the inverter's AC settings to different settings than those provided by default for the country of the installation site, or perform other modifications. A full description of the Configuration Tool is provided in the *SolarEdge Configuration Tool Software Guide*.

Refer to the following table to determine the correct fuse size to use at the connection point of the Single Phase Inverter to the grid:

Inverter	Maximum Output Current	Suggested Fuse
SE7k	11.5 A	12 A
SE8k	13.5 A	16 A
SE9k	15.5 A	16 A
SE10k	17.5 A	20 A
SE12k	19.5 A	25 A

**WARNING!**

For more wiring information, you may refer to the Application Note called *SolarEdge Recommended AC Wiring*, which can be accessed from the SolarEdge website.

**WARNING!**

You should also refer to the technical specifications in *Appendix B, Technical Specifications* on page 81. Pay special attention to the inverter specifications because they may differ slightly in different countries.

**WARNING!**

It is essential to connect the PE (ground) wiring before connecting the AC Line and Neutral wires.

**WARNING!**

Grounding of the DC side is prohibited because the Three Phase Inverter has no transformer.

Connecting the Three Phase Inverter

Connectors and Cables

The following shows the Three Phase Inverter connectors:

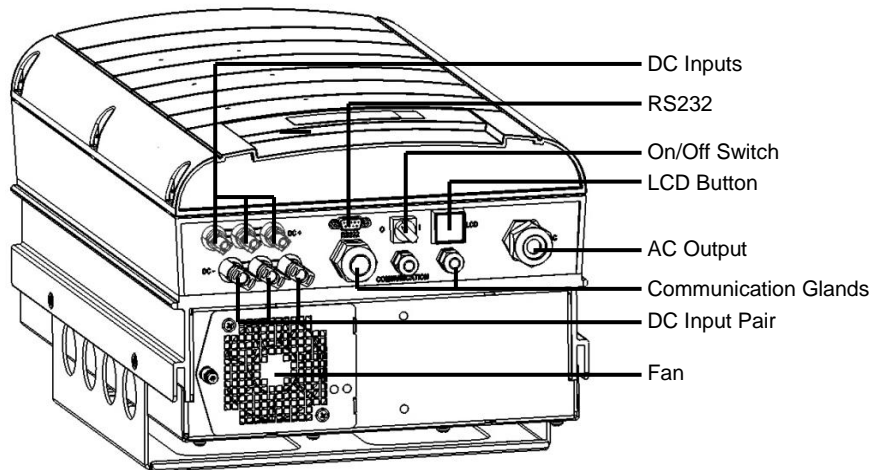

Figure 12: Three Phase Inverter Connectors

The following describes each connector, the wire requirements and gauge of its associated cable. All the Three Phase Inverter connectors are located at the bottom of the inverter, as described below:

- **ON/OFF Switch:** Turning this switch ON, powers up the Three Phase Inverter and starts the operation of the power optimizers. Turning it OFF, turns the inverter off and reduces the power optimizer voltage to a low safety voltage.
- **LCD Button:** Pressing this button lights up the LCD for 30 seconds.
- **RS232 Connector:**

- Provides a configuration, control and management connection to a locally connected PC or laptop, or to an external modem for connection to the SolarEdge Monitoring Portal. You may refer to the *Creating an RS232 (UART) Connection* section on page 52 for a description of how to set up this communication option to the SolarEdge Monitoring server.

You may refer to the *SolarEdge Monitoring Portal User Guide* for more information about the monitoring capacities.

- **Other Communication Options (Ethernet (LAN), RS485 or ZigBee):** Three other types of communication options can be used to connect the inverter to the SolarEdge Monitoring Portal. They are installed through the three cable glands. You may refer to *Chapter 6, Setting Up Communication* on page 50 for a description of how to set up these communication options to the SolarEdge Monitoring server.
- **AC Output:**
AC Cable External Gauge: M25 (13–18 mm diameter).
Each of the AC wires (Line, Neutral and PE) must be a copper wire with a cross-section of 8–16 mm².
- **DC Cable:** PV connectors.

Connecting the Three Phase Inverter

Opening the Cover

► **To connect AC wires to internal Three Phase Inverter terminals:**

- 1** Turn OFF the AC on the AC wires to be connected to the inverter by disconnecting the circuit breakers on the main circuit board.
- 2** Turn off the ON/OFF switch at the bottom of the inverter.
- 3** Turn off the DC switch on the main circuit board, if one exists.
- 4** If the inverter was on prior to disconnecting the switch, then wait at least five minutes before opening the cover of the inverter.

**WARNING!**

Do not open the cover of the Three Phase Inverter before you turn OFF the ON/OFF switch at the bottom of the inverter and the DC switch of the main circuit board.

**WARNING!**

Verify that the ON/OFF switch at the bottom of the inverter is OFF.

- 5 Unscrew the Allen screws on the cover of the chassis (on its front) and lift the cover up.
- 6 The inverter assembly is connected to the chassis cover by a green and yellow grounding cable.

**WARNING!**

The cover grounding cable may be removed after the cover is removed. However, the cover grounding cable **MUST** be reconnected before reassembly of the cover.

- 7 **Connecting the AC Wires:** Strip off the isolation and expose the five wires in the AC cable, as follows:

- Line 1 (L)
- Line 2 (L)
- Line 3 (L)
- Neutral (N)
- Protective Earth (PE) wire

The lengths of the wires to strip are as follows:

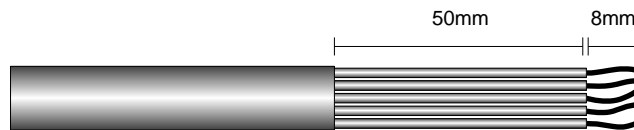

Figure 13: Wire Lengths to Strip

- Strip 8 mm for contact.
- Individual cable length 50 mm.

**WARNING!**

Make sure to connect the PE (ground) connector first.

- 8 Insert the cable through the AC cable gland on the right and connect the wires to the appropriate terminal connectors according to their labels: PE, L1, L2, L3 and N.

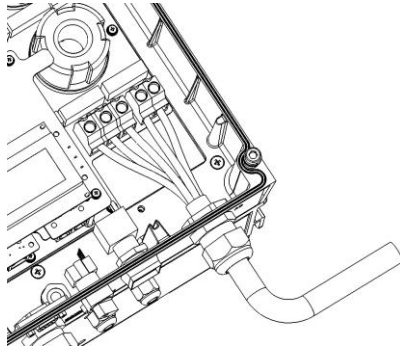

Figure 14: Inserting the Cable Through the AC Cable Gland

- 9 Tighten the screws of each wire terminal according to the following torque:
 - Tightening moment of terminal 0.5-0.6 Nm.
 - Gland torque 2.8-3.3 Nm.
- 10 Verify that there are no whiskers in each terminal connector and that the unused ports of the terminals are sealed.

Connecting Cables to the Three Phase Inverter Chassis

► To connect DC cables to the Three Phase Inverter:

- 1 Connect the DC connectors from the photovoltaic installation to the DC+ and DC- connectors as indicated.
Two strings may be connected in parallel to both DC inputs of the inverter. They are simply wired together in the terminal block inside.

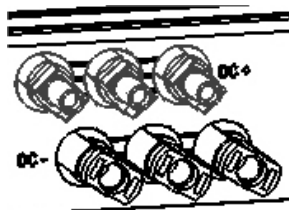

Figure 15: Connecting the DC Cables to the Inverter

If more than two strings are required, they can be connected in parallel in an external combiner box before connecting a unified DC connection to the inverter.

**NOTE:**

Due to the SolarEdge architecture, the parallel strings may be of different lengths and therefore do not necessarily need to be connected to an identical number of power optimizers.

Completing the Three Phase Inverter Installation

After completing all connections, the **inverter must be configured to the proper country**. The inverter may be configured according to the site's requirements using the inverter's internal buttons or by using the SolarEdge Configuration Tool connected to an RS232 port. For more information, you may refer to the *Configuring the Inverter Using the LCD Panel and User Buttons* section on page 67.

If you plan to use the SolarEdge Monitoring Portal to access SolarEdge site information, you may need to add a physical connection to the proper communication option. Connecting the inverter to the SolarEdge Monitoring Server via a LAN, an external modem connected to an RS232 port, an RS485 bus or a ZigBee modem is described in *Chapter 6, Setting Up Communication* on page 50.

Closing the Cover

► To close the cover:

- 1 Make sure to reattach the chassis grounding wire, if it was removed.

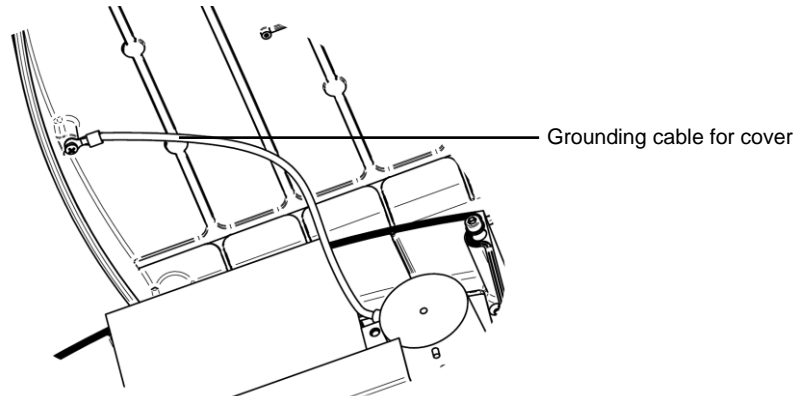

Figure 16: Chassis Grounding Wire Connection

- 2 Shut the chassis cover and secure it by tightening the screws.
- 3 For proper sealing, first tighten the corner screws and then the two central screws. The recommended order can be seen in the following figure:

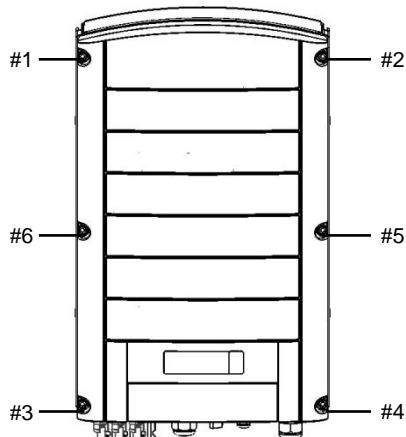

Figure 17: Tightening the Screws

Residual Current Device



IMPORTANT SAFETY FEATURE:

All SolarEdge inverters incorporate a certified internal Residual Current Device (RCD) in order to protect against possible electrocution and fire hazard in case of a malfunction in the PV array, cables or inverter.

An external **RCD is required** in some countries. In these cases, the installer must check which type of RCD is required by the relevant electric code. **SolarEdge recommends using a type-A RCD. The recommended RCD value is 100mA or 300mA unless a lower value is required by the specific local electric codes.**

In installations where the local electric code requires the use of a lower leakage RCD, the discharge current may trip the RCD. The following steps can be taken in order to avoid this problem:

- 1** It is important to select an appropriate RCD in order to ensure proper operation of the installation. Although the RCD used in such cases is a 30mA RCD, it may still trip at 15mA (according to IEC 61008). Good quality RCDs will trip at a higher value.
- 2** Configure the trip voltage of the inverters' internal RCD to a lower current than the trip current of the external RCD. The internal RCD may still trip if the current is higher than the allowed current, but because the internal inverter RCD automatically resets when the residual currents are low it does not require a manual reset. You may consult with the SolarEdge support center for assistance with this issue.
- 3** Certain PV panels (with low capacitance leakage to the frame) are preferable.

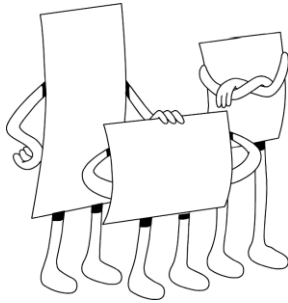

Chapter 4

Commissioning the Installation

Commissioning – Workflow

The following workflow describes how to activate the system, commission the installation and verify the proper functioning of the system.

- **Step 1, Activating the System**, page 38
- Step 2, Pairing Power Optimizers to the Inverter, page 39
- **Step 3, Verifying Proper Operation**, page 41
- **Step 4, Reporting Installation Data**, page 42

**NOTE:**

Keep this manual accessible and preferably near the inverter.

Step 1, Activating the System

This section describes how to perform the initial activation stages of the SolarEdge system.

These stages are preformed after the inverter and power optimizers have been installed and the power optimizers have been connected to the inverter.

► To activate the SolarEdge installation:

- 1 Power OFF the Three Phase Inverter by turning off the ON/OFF switch at the bottom of the inverter and the DC switch of the main circuit board (if exists).
- 2 Turn on the AC to the inverter.
- 3 If the site is installed with an external DC switch between the power optimizers and the inverter(s), then turn it ON. A message similar to the following message appears on the inverter's LCD panel:

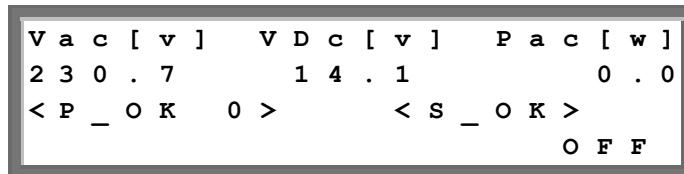

The LCD panel displays the following information:

V a c [v]	V D c [v]	P a c [w]
2 3 0 . 7	1 4 . 1	0 . 0
< P _ O K 0 >	< S _ O K >	O F F

- 4 Verify that **P_OK** appears, which indicates a connection to the power optimizers, and that at least one power optimizer is sending monitoring data. The number 0 indicates that no power optimizer has been paired to this inverter. If you are re-pairing the power optimizers and inverters, the number indicates the number of power optimizers that have been paired in the past. If **P_OK** does not appear, check the power optimizer, strings and DC input connections.
- 5 If the inverter is connected to the SolarEdge Monitoring server, verify that **S_OK** appears. This denotes that the connection to the server is successful.
- 6 Verify that the **Vac [v]** on the LCD panel specifies the grid's correct AC output voltage, in Volts.

- 7 Verify that the **V_{dc} [v]** on the LCD panel specifies the DC input voltage, in Volts. There should be a safety voltage of 1 V for each power optimizer connected to the inverter.

**NOTE:**

A measurement error on the inverter LCD of ± 3 V is OK.

**NOTE:**

If the LCD panel shows 0 V:

- Verify that the PV modules are not shaded or otherwise obstructed.
- Check for proper power optimizer, string and DC input connection.
- Verify the correct polarity of the DC input connection.

- 8 Verify that **P_{ac} [w]** on the LCD Panel specifies **0** as the AC output power, in Watts. This is because the inverter is still off.

**WARNING!**

Verify that the ON/OFF indicator on the LCD panel, described above, reads OFF.

Step 2, Pairing Power Optimizers to the Inverter

After all connections are made, all the power optimizers must be logically paired to their inverter before they can start working with it. This step describes how to pair power optimizers to the inverter, meaning to assign each inverter to the power optimizers from which it will produce power.

**NOTE:**

The power optimizer does not start producing power until it is paired with an inverter.

► **To pair the power optimizers to the inverter:**

- 1 Turn the ON/OFF switch at the bottom of the inverter to off. Press the inverter's LCD Light button for **15 seconds**. The following screen is displayed:

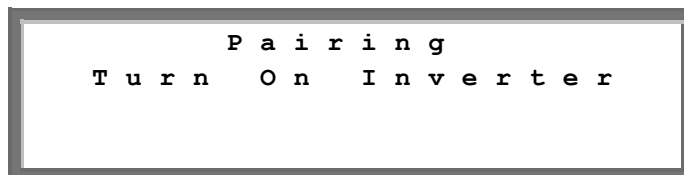

- 2 Turn on the inverter ON/OFF switch at the bottom of the inverter within five seconds. If you do not turn ON the inverter ON/OFF switch within five seconds, the inverter then exits pairing mode.

The following screen is then displayed indicating that the inverter is performing the process of pairing and is assigning power optimizers to the inverter.

```
          P a i r i n g
R e m a i n i n g   [ S e c ] :   1 0 4
```

This message displays a countdown of the seconds until it completes the pairing process. If pairing fails, an error is displayed. This error appears only if the above steps were not followed. If an error appears, then follow the pairing steps again.

After commissioning succeeds, the following message is displayed:

```
          P a i r i n g
P a i r i n g   C o m p l e t e d
```

- 3 Since at this stage the ON/OFF switch at the bottom of the inverter is ON, the power optimizers start producing power and the inverter starts converting AC.

**WARNING!**

After you turn ON the ON/OFF switch of the Three Phase Inverter, the DC cables carry a high voltage and the power optimizers no longer output a safe 1 V output.

If the inverter starts converting after the initial connection to the AC, the inverter then goes into Standby mode until enough power is generated (the inverter LED flickers green). While the inverter is in Standby mode, the following message is displayed:

```
          W a k i n g   U P . . .
R e m a i n i n g :   0 5 1 S e c
```

During this time, the inverter monitors the grid and verifies correct grid voltage and frequency. This message indicates how many seconds remain until the inverter will be in Production mode. This amount of time is in accordance with the regulations of each country, and is typically between three to five minutes.

The inverter then automatically goes to Production mode and produces power (the inverter LED is steady green).

Step 3, Verifying Proper Operation

After the proper wake-up delay time is over, the following message appears on the inverter's LCD panel:

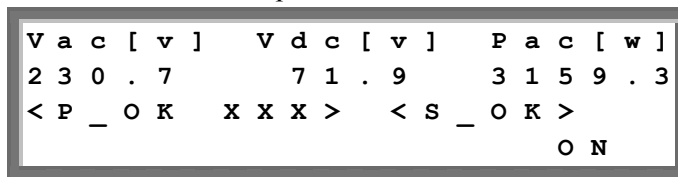

```
V a c [ v ]      V d c [ v ]      P a c [ w ]
2 3 0 . 7      7 1 . 9      3 1 5 9 . 3
< P _ O K   X X X >   < S _ O K >
                                O N
```

► To verify proper operation:

- 1 Verify that the inverter LED is steady green.
- 2 Verify that the ON/OFF indicator on the LCD panel, described above, reads **ON**.
- 3 Verify that **P_OK** appears to indicate a connection to the power optimizers. Also, verify that **S_OK** appears, if the inverter is connected to the SolarEdge Monitoring Server.
- 4 Verify that the total number of power optimizers connected to the inverter appears next to the **P_OK** indicator on the LCD panel. If this number is too low, then it may mean that one or more of the power optimizers are not connected properly or the pairing process may have not been completely successful. For example, due to complete shading over one of the modules or insufficient sunlight during the pairing process.

**NOTE:**

It can take up to 15 minutes for all power optimizers to transmit their telemetries and to be counted on the LCD screen.

- 5** Verify that the **Vac [v]** on the LCD panel specifies the grid's correct AC output voltage in Volts.
- 6** Verify that the **Vdc [v]** on the LCD panel specifies the DC input voltage in Volts, which should be between 250 V and 450 V.
- 7** Verify that **Pac [w]** on the LCD Panel specifies the **total** AC output power produced, in Watts.

**NOTE:**

Take note of the serial # on the inverter's sticker and on its warranty card. This information is used in the SolarEdge Monitoring Portal to identify this inverter and is needed to open a new site in the monitoring portal.

Congratulations! Your SolarEdge power harvesting system is now operational.

Step 4, Reporting and Monitoring Installation Data

The SolarEdge Monitoring Portal enables you to access SolarEdge site information, as described in the *SolarEdge Monitoring Portal User Guide*, as well as receive up-to-date information from the installation site for viewing in a physical or logical view.

After a site is opened in the SolarEdge Monitoring Server, you can access all the monitored data about that site.

To register a new site, fill in the online form at <http://www.solaredge.com/groups/site-registration>.

The serial number(s) of the inverter(s) must be specified in order to open a new site.

The SolarEdge Monitoring Server also enables you to display a logical and physical schematic layout of the installed power optimizers, as follows:

- **Logical Layout:** Shows a schematic logical layout of the components in the fields, meaning inverters, clusters, strings and panels and their electrical connectivity. This view enables you to see a logical view of which panels are connected in each string, which strings are connected to each inverter and so on.
- **Physical Layout:** Shows a schematic physical layout of the components in the fields, meaning inverters, clusters, strings and panels and their electrical connectivity. This view enables you to see a **physical bird's eye view** of the installation site showing which panels are connected in each string, which strings are connected to each inverter and so on.

This window enables you to:

- View the latest performance of specific components.
- Find underperforming components, such as panels, by comparing their performance to that of other components of the same type.
- Pinpoint the location of alerted components.
- See how components are connected to each other.

In order to enable the SolarEdge Monitoring Portal to show the strings and physical location of power optimizers, you may first report the physical and logical mapping of the installed power optimizers by mail, email or fax to SolarEdge. SolarEdge will then upload this information to the SolarEdge Monitoring Server.



IMPORTANT NOTE:

Even if you do not report the physical and logical mapping of the installed power optimizers to SolarEdge, the SolarEdge Monitoring Portal will still show the logical layout indicating which power optimizers are connected to which inverters. However, it will not show strings or the physical location of power optimizers.

This process prepares the SolarEdge Monitoring Portal for receiving up-to-date information from the installation site and for displaying it in a physical or logical view.

The inverter may be connected to the SolarEdge Monitoring Server via a LAN or an external modem connected to the RS232 port. Alternatively, you can connect the inverter to another inverter that is already connected to the server.

The inverter-to-inverter connection is made by an RS485 bus or a ZigBee modem. This connection enables the inverters to send the latest data collected from the power optimizers and inverters to the SolarEdge Monitoring Server.

If the inverter is properly connected to the internet, as described in the *Step 3, Verifying Proper Operation* section on page 41, then the **S_OK** appears in the inverter's LCD screen.

Providing Installation Information



IMPORTANT NOTE:

Be sure to record power optimizer serial numbers during their installation, as this information may be required later for troubleshooting.

iPhone Site Mapper

SolarEdge provides an iPhone Site Mapper that helps you collect information about your installation. This application leads you through the process of photographing the labels on each inverter and power optimizer. It then helps you transmit this collected information to SolarEdge's Monitoring Portal (which was described on the previous pages). The SolarEdge iPhone Mapping Application can be downloaded from the SolarEdge website.

Emailing Installation Information to SolarEdge

If not using the iPhone site mapper, the following information may be sent to SolarEdge by mail, email or fax:

- **Installation Name:** The name by which you want this installation to appear in your personal site list in the SolarEdge Monitoring Portal.
- **Installation Location (City, State, Country):** This information is required if you want the SolarEdge Monitoring Portal to show the local weather data, the local PV feed-in tariff or the local electricity tariff.

- **Inverter Serial Number(s) at the Site:** Each inverter's serial number is printed on a sticker on the side of the inverter, on the inverter warranty card and on the inverter box. Each inverter's sticker has a detachable tab on which the inverter's serial number is printed. You can remove this tab and stick it on a piece of paper. The power optimizers also have a sticker with a detachable tab on which the power optimizer's serial number is printed.

An easy way to report all the inverters' and power optimizers' serial numbers to SolarEdge is to collect all the inverters' and power optimizers' stickers, stick them on the same piece of paper and then fax this paper to SolarEdge.

If you wish, you can also supply the following information.

- **Logical Mapping:** Showing which power optimizer is located in which string and in which order. You can specify the logical mapping of the strings and power optimizers, as follows:

P.Inverter_number.String_number.power optimizer_number.

For example, the third power optimizer connected to a power optimizer in the second string in the #4 inverter in the installation is represented as **P.4.2.3**.

- **Physical Mapping:** Showing a physical map (a drawing) of the location of each power optimizer in the installation. Providing this is easiest using the *SolarEdge Physical Layout Template* available on the SolarEdge website.

The logical and physical mapping can be used in the future for debugging a problem using the SolarEdge Monitoring Portal.



Chapter 5

Replacing and Adding System Components

Modifying an Existing Installation

This section describes how to modify an existing installation that has been operating properly for a while.

► **To modify an existing installation:**

- 1 Shut down the inverter by turning OFF its ON/OFF switch and the DC switch of the main circuit board. The inverter goes into Shutdown mode and displays the following message:

```
DC VOLTAGE NOT SAFE!  
DO NOT DISCONNECT!  
VDC : 72.0
```

This message is displayed until the DC is safe. The default safety voltage is 50 V.



WARNING!

Do not touch the DC power connections until the DC voltage is at a safe level. Doing so may cause personal damage, damage to the device and/or danger of fire.

- 2 Switch off the AC to the inverter.



WARNING!

If you cannot see the inverter panel, or there is a malfunction indicated on the LCD panel, then switch off the AC to the inverter and wait five minutes for the input capacity of the inverter to discharge.

- 3 You can now add or remove power optimizers, add or remove strings, change connections of power optimizers or strings or replace the inverter.
- 4 Perform the *Commissioning – Workflow*, as described on page 37.

**NOTE:**

If you are permanently dismantling the installation or part of it, make sure to use the disposal method dictated by the regulations of the country in which the inverters are installed.

► **To move one or more power optimizers from one inverter to another in the same site:**

- 1 Turn both inverters OFF, as described above.
- 2 Connect each power optimizer to the strings of the other inverter.
- 3 Perform the *Commissioning – Workflow*, as described on page 37, on the inverter to which a power optimizer was added and only then perform the *Commissioning – Workflow* on the inverter from which a power optimizer was removed.

**CAUTION:**

Commissioning must first be performed on the inverter to which power optimizers were added, and only then on the inverter from which power optimizers were removed. Otherwise, the inverter to which power optimizers were added may be damaged.

Replacing the Fans

The inverter has two fans, one is accessible from the outside of the inverter (called Fan 1) and the other is internal and requires a SolarEdge technician to replace it (called Fan 2).

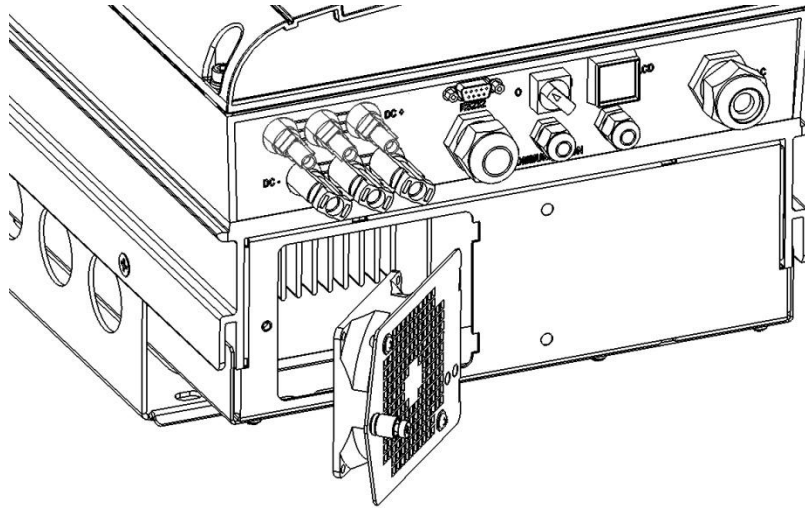

Figure 18: Inverter Fan 1

► **To replace Fan 1:**

- 1** Unscrew the single screw of the fan cover, shown above, using a Philips screw driver.
- 2** Open the fan door.
- 3** Disconnect the fan door connector, as shown below:

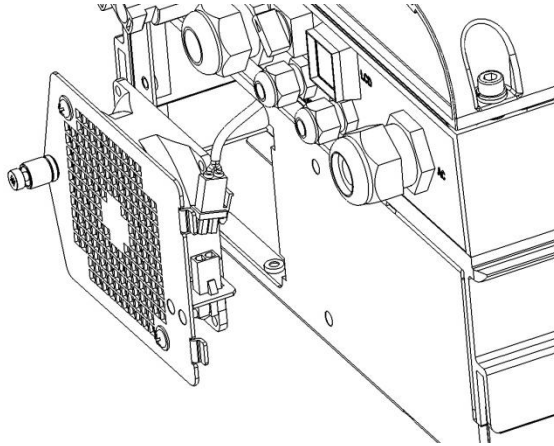
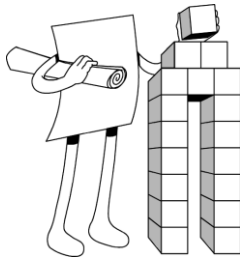

Figure 19: Fan Door Connector

- 4** Pull out the fan unit.
- 5** Replace the fan unit by pushing in a new fan.
- 6** Connect the fan door connector.
- 7** Check the *Fan Health Status* window to make sure that the fan was installed properly, as described in the *Fan Health Status Window* section on page 66.



Chapter 6

Setting Up Communication

Communication Dataflow

The SolarEdge site information can be accessed remotely using the SolarEdge Monitoring Portal, as described in the SolarEdge Monitoring Portal User Guide. In order to transfer monitoring data from a SolarEdge site to the SolarEdge Monitoring Portal, a communication connection must be set up, as described in this chapter. Communication setup is not required for power harvesting and is needed only when using the monitoring portal.

Power optimizers send information to the SolarEdge Inverter via DC lines. No added wires or configuration are required for this purpose. The inverter sends this information to the SolarEdge Monitoring Server through the Internet. The sections below describe how to set up this connection.

Communication Types

The following types of communication can be used to transfer the monitored information from the inverter to the SolarEdge Monitoring Server:

- **RS232 (UART):** page 52, This communication option is provided in all inverters by default. It is used to connect to any external modem that has an RS232 port.
- **Ethernet:** page 53, Enables the connection of the inverter directly to a LAN.

- **RS485:** page 56, Enables the connection of multiple inverters through the same bus, such that connecting only one inverter to the Internet is sufficient to provide communication services to all the inverters on the bus.

**NOTE:**

In addition, there are three types of wireless communication options that are available and purchased separately. They are: ZigBee, WiFi and GSM. Refer to relevant documentation for details about their installation.

Ethernet and RS485 are connected to a connector inside the inverter. The location of the connectors is indicated in the following figure:

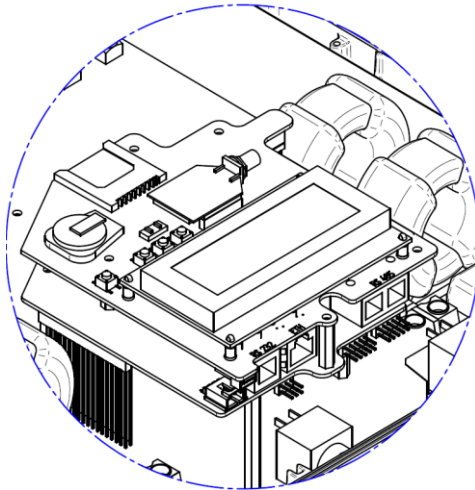

Figure 20: Ethernet and RS485 Connectors

**NOTE:**

Except for RS232, communication options are optional and can be ordered when ordering the inverter.

Creating an RS232 (UART) Connection

This communication option is provided in all inverters by default. It enables you to connect the inverter via modems supplied by SolarEdge. You may refer to the SolarEdge website for a list of the types of modems offered, which includes GSM and WiFi modems. Each modem is provided with its own user manual which should be reviewed.



NOTE:

When connecting via RS232, make sure to use a shielded connector so as not to interfere with other devices in the vicinity.

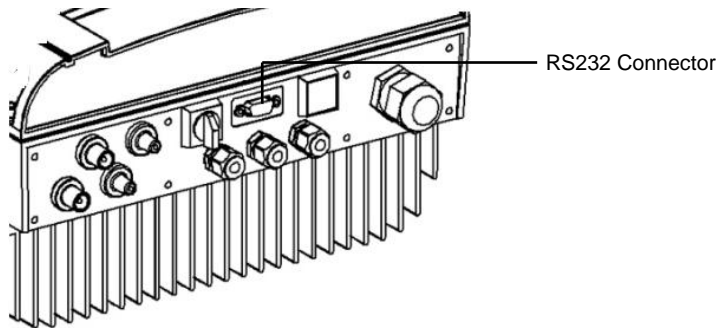

Figure 21: RS232 Connector



IMPORTANT SAFETY FEATURE:

The RS232 connector on the bottom of the inverter is safe to touch during normal operation of the Single Phase Inverter

► To configure RS232 communication to the SolarEdge Monitoring Server:

- 1 Using the user buttons, select the **5.1.2 RS232** option under the **Communication** → **Server** menu (5.1), as described in the *Configuring the Inverter Using the LCD Panel and User Buttons* section on page 67.
- 2 Follow the instructions of your SolarEdge modem for model-specific configuration options.

- 3 Connect the modem to the inverter through the RS232 connector, which is the nine-pin connector on the bottom of the inverter. There is no need to open the inverter cover.

To verify the connection, you may refer to the *Verifying the Connection* section on page 59.

Creating an Ethernet (LAN) Connection

This communication option enables you to use an Ethernet connection to connect the inverter to a LAN.

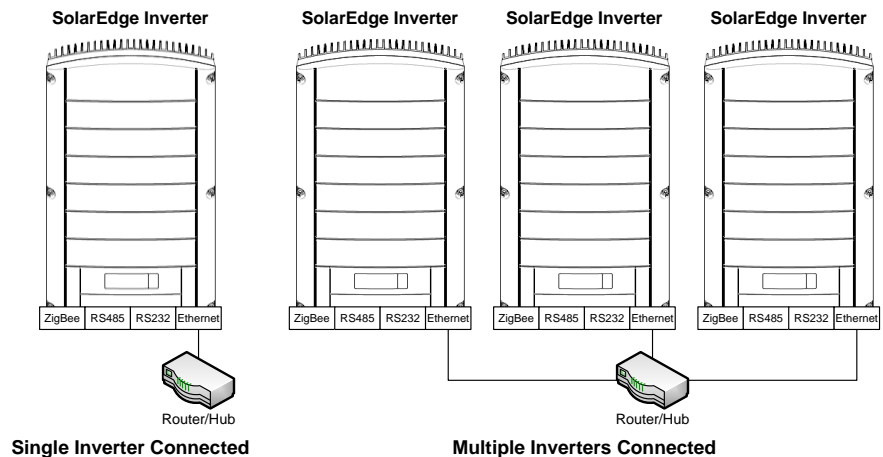

Figure 22: Example of Ethernet Connection

► To connect the Ethernet communication to the SolarEdge Monitoring server:

- 1 Open the cover of the inverter, as described in the *Opening the Cover* section on page 31.
- 2 Using the user buttons, choose the **5.1.1 LAN** option under the **Communication** → **Server** menu (**5.1**), as described in the *Configuring the Inverter Using the LCD Panel and User Buttons* section on page 67.

- 3 Configure the **LAN** options under the **Communication** menu (DHCP [5.2.2] and IP [5.2.1] configurations), as described in the *Configuring the Inverter Using the LCD Panel and User Buttons* section on page 67.
- 4 Connect the Ethernet cable to the RJ45 plug on board in the inverter, as follows:
 - Insert the Ethernet wire via one of the small cable glands on the bottom of the inverter. **If required, remove the existing plug.** The inverter glands come pre-sealed from the factory. Removing the sealing is needed to insert the cable.

**CAUTION:**

If a gland is opened and not used, then make sure to reseal it. Otherwise, it may affect the inverter's functionality.

**CAUTION:**

The internal side of the gland includes an o-ring, which should be used to ensure proper sealing.

- Remove the cable's external isolation using the crimping tool and expose the wires. Standard cables have 8 wires (4 twisted pairs). For Ethernet communication, 4 wires (2 twisted pairs) are used.

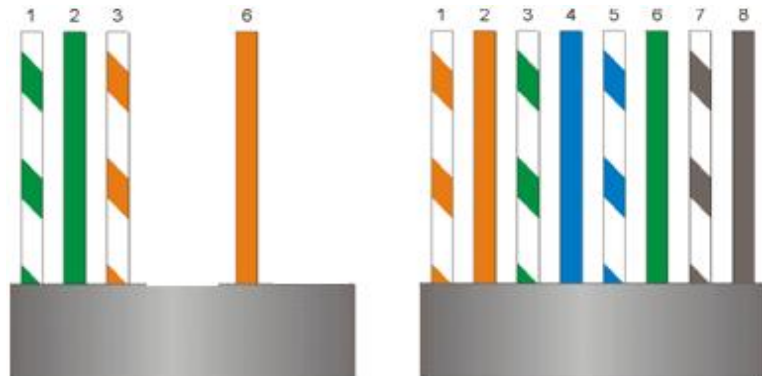

Figure 23: Preparing Connector Wiring

Only wires numbered 1, 2, 3 and 6 in the diagram on the left above should be connected. To make crimping easier, wires numbered 3, 6, 7 and 8 do not need to be connected.

- Insert the 4 wires into the RJ45 connector. Make sure to use pins 1, 2, 3 and 6.

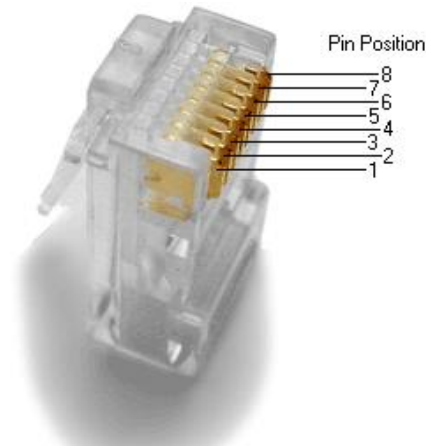

Figure 24: Inserting Wires into the RJ45 Connector

- Use the Ethernet crimper to crimp the wires.
 - Connect the Ethernet connector to the RJ45 plug on board in the inverter, as shown in Figure 20.
- 5** Connect the other end of the Ethernet cable to the RJ45 plug of the Ethernet hub or router. You can connect more than one inverter to the same hub or to different hubs, as required. Each inverter sends its monitored data independently to the SolarEdge Monitoring server. All connections are initiated from the inverter so that no port forwarding is required.
 - 6** Close the inverter cover, as described in the *Closing the Cover* section on page 35.
 - 7** Verify the connection, as described in the *Verifying the Connection* section on page 59.



NOTE:

If your network has a firewall, then you may need to configure it to enable the connection to the following address:

Destination Address: prod.solaredge.com

Port: 22222

Creating an RS485 Bus Connection

The RS485 option enables you to create a bus of connected inverters (consisting of up to 30 Slave inverters and 1 Master inverter). Using this option, inverters are connected to each other in a chain, meaning the first inverter in the chain is connected to the next inverter in the chain via its RS485 connector. The first inverter in the chain and the last inverter in the chain must be terminated.

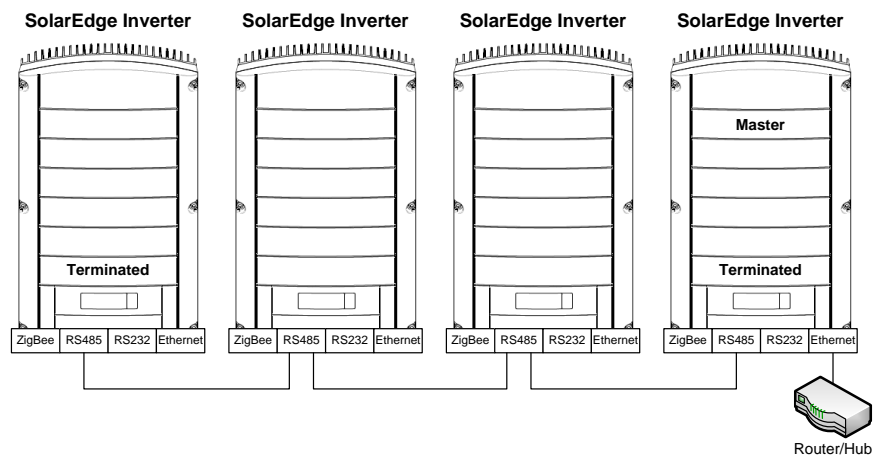

Figure 25: Example of RS485 Bus Connection

Each inverter must be connected according to the instructions below.

► **To connect the RS485 communication bus:**

- 1 Open the cover of the inverter, as described in the *Opening the Cover* section on page 31.
- 2 Using the user buttons, select the **5.1.3 RS485** option under the **Communication** → **Server** menu (**5.1**), as described in the *Configuring the Inverter Using the LCD Panel and User Buttons* section on page 67.



NOTE:

By default, all inverters are Slaves. Slaves can be configured to connect via RS485 automatically from the RS485 Master menu (5.3.1.3 in the Master), instead of as described in Step 2 above.

- 3** The RS485 bus uses a four-wire telephone cable and a six-wire RJ11 connector (also known as RJ25). Insert the wire via one of the small cable glands. The glands come from the factory pre sealed. Removal of the sealing is required in order to insert the cable.

**CAUTION:**

If a gland is opened and not used, be sure to reseal it. Otherwise, it may affect the inverter's functionality.

- 4** After inserting the wire, crimp a connector using a standard telephone wire crimper. Two pins (numbered 2 and 3) must be connected. The two wires must both belong to the same twisted pair, which is usually indicated by similarly colored wire. In addition, a grounding wire that is connected to pin number 6 must also be connected. For this purpose, you can use any remaining wire of the telephone cable. The wiring on the next inverter should be the same.



Figure 26: Crimping the Wires

- 5** Connect the RS485 cable connector to either of the RS485 plugs on boards in the inverter.
- 6** Connect the other end of the RS485 cable of the first inverter through the gland to the RS485 connector on the board of the next inverter in the chain, as described above.
- 7** You can use both RS485 connectors to wire up to two inverters – one to the left and one to the right.

- 8** The two inverters at the ends of the chain (meaning the first inverter and the last inverter) must be terminated by switching a termination dip-switch inside the inverter to ON. The switch is marked SW6 and it is the switch closest to the ESC button, as shown below:

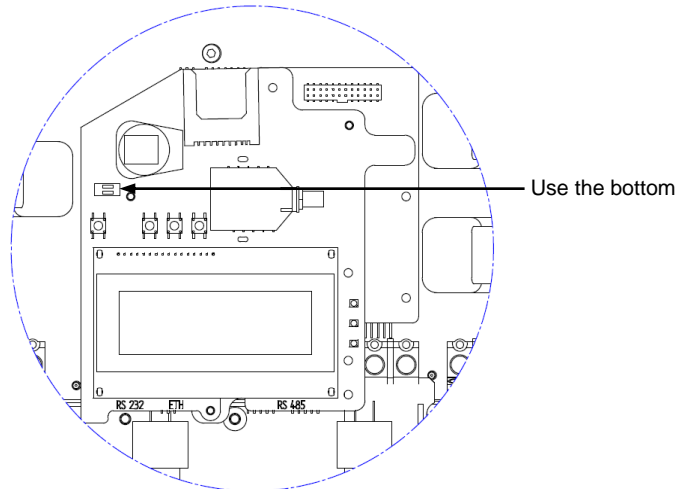

Figure 27: RS485 Termination Switch



NOTE:

Only the two inverters at the ends of the chain should be terminated for best performance. The other inverters in the chain should have the termination switch OFF.

- 9** Choose a single inverter to be the connection point between the RS485 bus and the SolarEdge Monitoring Server.
- 10** Connect the Master, as described above, to the SolarEdge Monitoring Server via either Ethernet, as described in the *Creating an Ethernet (LAN) Connection* section on page 53, or RS232, as described in the *Creating an RS232 (UART) Connection* section on page 52.

Ensure that you select either the **Ethernet (5.1.1)** or **RS232 (5.1.2)** option under the **Communication → Server** menu (5.1), as described in the *Configuring the Inverter Using the LCD Panel and User Buttons* section on page 67.

- On the Master inverter under the **5. Communication** menu, configure the **5.3 RS485** option of the inverter to MASTER, as described in the *Configuring the Inverter Using the LCD Panel and User Buttons* section on page 67.
- Select the **5.3.3 Slave Detect +** option to initiate automatic detection of the Slave inverters that are connected to this Master inverter. This verifies that they are configured as Slaves.
- The Master should report the correct number of slaves. If it does not, verify the connections and terminations as described above.

11 Verify the connection of the Master to the SolarEdge Server, as described in the *Verifying the Connection* section below.

Verifying the Connection

► **To verify the connection:**

- 1** Verify that the DC circuit breaker is OFF.
- 2** Verify that the inverter's ON/OFF switch is still OFF.
- 3** Turn ON the AC to the inverter by using the circuit breakers on the main circuit board.
- 4** Wait for the inverter to connect to the SolarEdge Monitoring Server. This may take up to two minutes.

- 5 Verify that the LCD panel displays a window similar to the following:

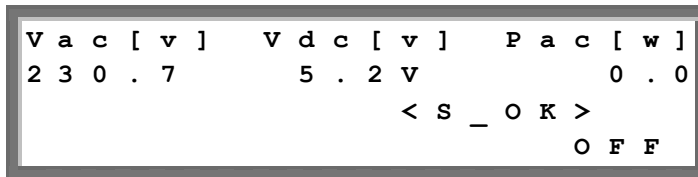

- **S_OK:** Verify that **S_OK** appears on the panel to indicate a functioning connection to the SolarEdge Monitoring Server, which was validated during the last two minutes.

**NOTE:**

If the S_OK indication is not displayed, then perform the following:
Use another method (unrelated to the SolarEdge Inverter) to check whether the network and modem are operating properly. For example, connect a laptop to the Ethernet modem and connect to the Internet. Check whether a firewall or another device is blocking transmission. Check the configuration of the inverter.

Troubleshooting Communication

► **To troubleshoot a communication problem:**

- 1 Check that the modem or hub/router is functioning properly.
- 2 Check that the connection to the internal connector on the inverter board is performed properly through its gland at its bottom.
- 3 Check that the selected communication option (RS232, Ethernet [LAN], RS485 or ZigBee) is configuring properly using the inverter's LCD panel.
- 4 Check whether a firewall or another type of network filter is blocking communication.
- 5 If you are using a ZigBee connection and there is interference on the channel being used, then change the channel.

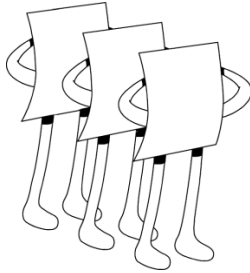

Chapter 7

Inverter User Interface

Inverter LCD Panel and LEDs

The front of the Three Phase Inverter has a small LCD panel and three LEDs, as shown below:

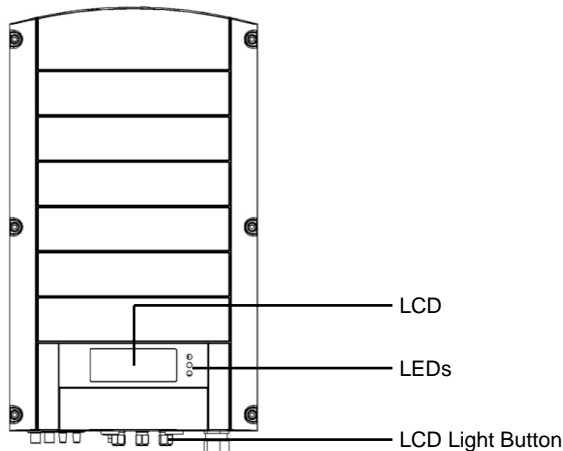

Figure 28: Three Phase Inverter – Front

The LCD panel has three LED indicators, as follows:

- **Power Production (Green):** Indicates whether the inverter is producing power or not, as follows:
 - **On:** The inverter is producing power.
 - **Blinking:** The inverter is in Standby mode, meaning it is preparing to produce power. The inverter is in Standby mode until enough power is generated. The inverter then automatically goes to Production mode and produces power.

- **Off:** The inverter is not producing power. This may be during Night mode, when the ON/OFF switch is OFF or when an error occurs.
- **Module Communication (Yellow):** This LED blinks quickly each time monitoring information is received from a power optimizer. In addition this LED blinks while the inverter is being shut down.
- **Fault (Red):** Indicates that an error has occurred. You may refer to the *Appendix A, Errors and Troubleshooting* on page 75 for more information. In addition, this LED blinks while the inverter is being shut down.

All LEDs are on while the inverter is being configured using the buttons inside the inverter.

Inverter LCD Panel and User Buttons

The following describes the various stages and times of day that you may use the LCD panel and user buttons:

- **Normal operation:** The LCD panel allows the user to check that the inverter is working properly. You may refer to the *Normal Operation* section on page 63 for a description of this window. Use the LCD button to toggle through the informative displays.
- **Inverter startup:** After the inverter is turned on and begins producing power, the LCD panel displays the inverter's status in the *Main Inverter Status* window that shows the total voltage and power, as described in the *Main Inverter Status Window* section on page 64.
- **Inverter shutting down:** The inverter automatically goes into Night mode and turns off the LCD when it is no longer supplied power by at least one string of minimum length.
- **After installation of the inverter:** The field technician must perform basic configuration of the inverter, as described in the *Configuring the Inverter Using the LCD Panel and User Buttons* section on page 67.

- **Error messages:** In the event of a problem, an error message may be displayed on the LCD panel. You may refer to *Appendix A, Errors and Troubleshooting* on page 75 and the *Configuring the Inverter Using the LCD Panel* section on page 67 for more information.

Normal Operation

Pressing the inverter's LCD light button located on its bottom turns on the LCD's backlight and displays the messages on the LCD panel.

The backlight is displayed for 30 seconds. This length of time is configurable, as described on page 72.

The following screens appear, one after the other, when you press the LCD light button:

- Initial Inverter Status Window, below
- **Main Inverter Status Window**, page 64
- **Energy Meter Window**, page 64
- **Telemetry Window**, page 65

You can toggle between these windows by clicking the LCD light button.

Initial Inverter Status Window

```

V a c [ v ]   V d c [ v ]   P a c [ w ]
2 3 0 . 7     3 7 1 . 9     2 3 4 9 . 3
< P _ O K   X X >   < S _ O K >
                                O N

```

- **Vac [v]:** Specifies the average AC output voltage **Neutral (N)**, in Volts.
- **Vdc [v]:** Specifies the DC input voltage **Neutral (N)**, in Volts.
- **Pac [w]:** Specifies the total AC output power of all three phases, in Watts.

- **P_OK XX:** Indicates a functioning DC line-communication connection to the SolarEdge power optimizers, which indicates that telemetry information was received within the last 10 minutes. XX is the number of paired power optimizers for which telemetries have been received by the inverter in the last two hours. YY is the number of paired power optimizers identified during the most recent pairing process. Both XX and YY should be the same. If they are not, it may indicate an access issue or pairing requirement that require your attention.
- **S_OK:** Indicates a functioning connection to the SolarEdge Monitoring Server, which was validated during the last two minutes. This connection is not mandatory for power generation.
- **ON/OFF:** Indicates the position of the inverter ON/OFF Switch.

Main Inverter Status Window

After you press the inverter's LCD light button to display the window shown above, you can press it again to display the *Inverter Main Status* window. This is the most informative window during the normal course of events, because it provides a quick overview of power, voltage and temperature, as described below:

V a c [v]	V d c [v]	P a c [w]
2 3 0 . 7	3 7 1 . 9	3 2 1 0 . 0
F a c [H z]		T e m p
5 0 . 0		2 2 . 3

Energy Meter Window

After you press the inverter's LCD light button to display the window shown above, you can press it again to display the *Inverter Energy Meter* window. This window displays the total energy [Wh] produced during the last day, month and year of the inverter, as described below:

D a y [W h]	:	0 . 0
M o n t h [K W h]	:	0 . 0
Y e a r [K W h]	:	0 . 0
T o t a l [K W h]	:	0 . 0

**NOTE:**

The production data is accumulated according to an internal real-time clock. If the inverter is connected to the SolarEdge Monitoring Server, it will automatically set the clock's time. If not, you may use the SolarEdge Configuration Tool to set the clock setting.

Telemetry Window

After you press the inverter's LCD light button to display the window shown above, you can press it again to display the *Inverter Telemetry* window. This window displays the telemetry of the last power optimizer to report its telemetry to the inverter, as described below. The display changes as each power optimizer sends its telemetry information. Each power optimizer sends its telemetry once within each 15-minute period.

**NOTE:**

This window is unique in that its backlight is ON by default for 15 minutes after you press the LCD light button (and not 30 seconds like other windows). This length of time can be configured, as described on page 72.

**NOTE:**

In order to verify proper installation, a technician may want to view the *Telemetry* window for some time in order to see that all power optimizers report their telemetries.

```
M o d u l e #      : M 3 2 5 6
E n e r g y [ W h ] :      0 . 0
V d c _ O [ V ]   :      6 9 . 5
V d c _ I [ V ]   :      2 9 . 5
```

Fan Health Status Window

After you press the inverter's LCD light button to display the window shown above, you can press it again to display the *Fan Health Status* window. This window provides information about the health of the inverter's two fans, as described below:

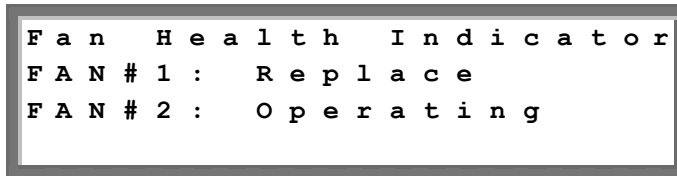

Each fan can have one of the following statuses:

- Operating
- Replace
- Not Working

When a fan has the status **Replace**, the display blinks constantly until it is replaced, as long as the unit is not in night mode.

The Fault LED does not light when in Replace status.

The **Error** section displays an error if the fan is faulty. You may refer to *Appendix A, Errors and Troubleshooting* on page 75 for a description of the error.

Clicking the LCD light button again redisplay the *Initial Inverter Status* window, as described on page 63.

Configuring the Inverter Using the LCD Panel and User Buttons

After installation of the inverter, a field technician can verify and perform basic configurations of the inverter. This section describes the various LCD messages and possible configurations using the user buttons.



IMPORTANT NOTE:

The inverter and its LCD panel start operation after at least one string of power optimizers is exposed to sunlight. Until then, the inverter is in Night mode and no LCD functions will work. The power optimizers do not need to be producing power during this time (they are in Safety mode if the ON/OFF switch is OFF), but at least one string must be connected to the inverter in order to enable its operation.



NOTE:

This process can also be performed using the SolarEdge configuration tool by connecting a PC or laptop to the inverter via its RS232 management port. This tool is described in the *SolarEdge Configuration Tool User Guide*.

► To configure the inverter:

- 1 Verify that the inverter's ON/OFF switch is OFF.
- 2 Press the LCD Light button once to turn ON the backlight.



WARNING!

If the inverter worked properly before this action, the following message is displayed:

```
DC VOLTAGE NOT SAFE!  
DO NOT DISCONNECT!  
VDC :      72.0
```

This message is displayed until the DC is safe.

The default safety voltage is 50 V.

Do not open the cover or open DC connectors until the voltage is indicated as safe or until at least five minutes have passed.

- 3** The following configuration procedures are performed with the inverter cover open. Open the cover, as described in the *Opening the Cover* section on page 31.

Four buttons for controlling the LCD panel menus are then accessible, as shown below:

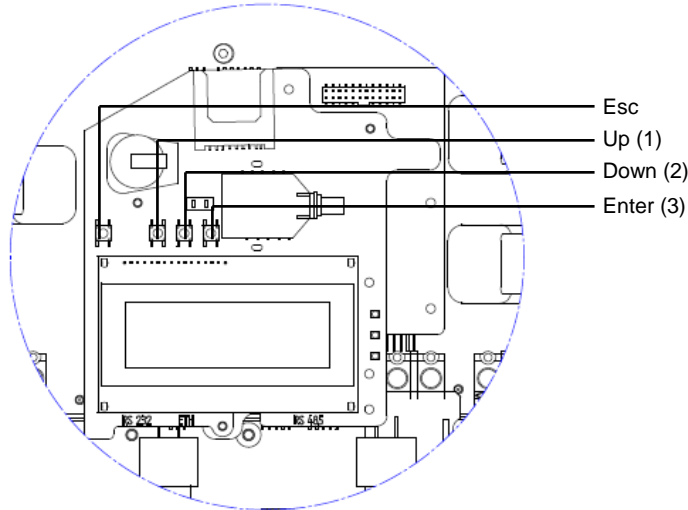
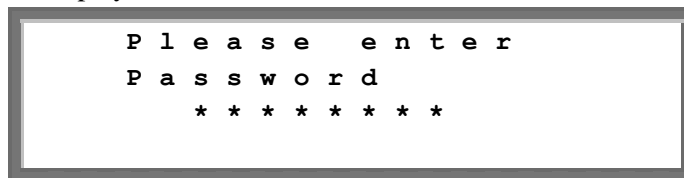

Figure 29: LCD Panel Menu Buttons

- **Esc:** Goes to the beginning of the currently entered parameter or to the previous menu.
 - **Up (1):** Goes up one option in a menu.
 - **Down (2):** Goes down one option in a menu.
 - **Enter (3):** Confirms the entry or selection of a parameter.
- 4** Press the **Enter** button for at least five seconds. The following message is displayed:



The inverter is now in Setup mode and all its LEDs are lit. The inverter automatically exits Setup mode if no buttons are pressed for more than two minutes.

- 5** Use the three right-most buttons inside the inverter (the **UP-1**, **Down-2** and **Enter-3** buttons), shown above, to type in the following default password: **12312312**. Inverter passwords are eight digits long, each digit being between 1 and 3. The following message is displayed:

```
* 1 .   C o u n t r y   < G E R >
  2 .   L a n g u a g e   < e n g >
  3 .   T e m p e r a t u r e   < C >
  4 .   D i s p l a y
  5 .   C o m m u n i c a t i o n
  6 .   C o u n t e r s
```

Configure each of these menu options.

The following shows a hierarchical tree of the menu options:

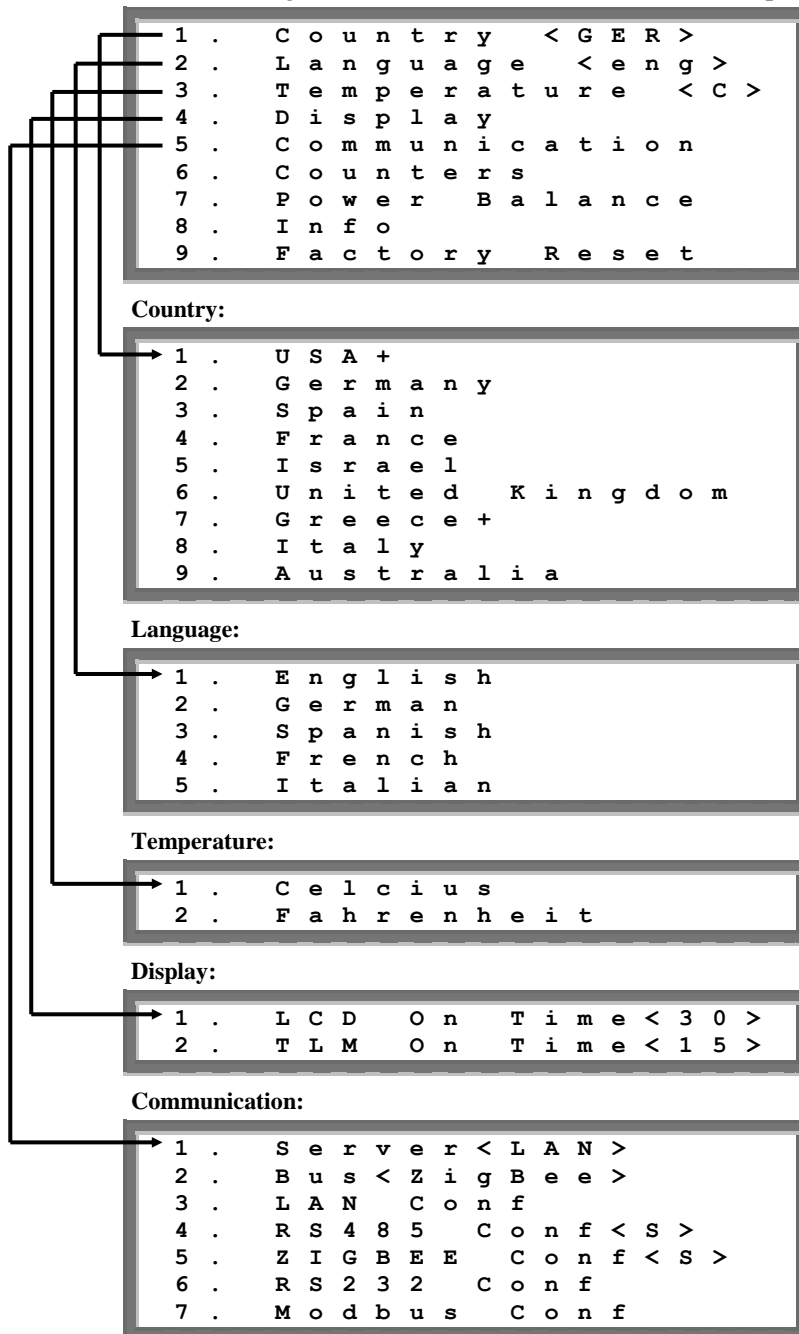

Figure 30: LCD Menu Options

Each menu option is described below.

Use the **Up** and **Down** buttons inside the inverter to move the asterisk (*) to the relevant menu option and then press the **Enter** button to select it.

Use the three rightmost buttons to type in a number if required.

Inverter Configuration Menu Options

- 1 Select the **1. Country** option to specify the country in which the inverter is installed. This parameter may arrive pre-configured. If so, verify that it is set to the proper country.



WARNING!

The inverter must be configured to the proper country in order to ensure that it functions properly with that country's grids.



NOTE:

If an inverter is not configured to any country, then it does not turn ON.

If no country is configured, its value is <NONE>. A list of countries is displayed. A + near the country indicates that another menu will be displayed after selection. After selecting the country, you are asked to confirm your selection in the confirmation screen. Toggle to **YES** and press **Enter** to confirm.

- 2 Select the **2. Language** option to select the language in which the LCD panel should display. The inverter may arrive pre-configured to the local language.
- 3 Select the **3. Temperature** option to select the units in which the temperature is displayed, as shown below:

The display shows either <C> or <F> according to whether **Celsius** or **Fahrenheit** was selected. The default is **Celsius**.

- 4** Select the **4. Display** option to display the following three options:
- **4.1 LCD On Time <30>**: Specifies the number of seconds that the LCD panel backlight is ON after the LCD light button is pressed. <30> represents the default value of 30 seconds.
 - **4.2 TLM On Time <15>**: Specifies the number of minutes that the LCD panel backlight is ON while viewing the *Telemetry* window. The default is **15** minutes.
 - **4.3 SW Version**: Displays version information describing various firmware inverter processors, as follows:

```

I D      :   0 0 0 0 0 0 0 F
D S P 1   V e r :           1 .      8 8
D S P 2   V e r :           0 .      8 1
C P U     V e r :           1 . 4 7 2 7

```

- **ID**: Displays the inverter ID, which should be the same as on the inverter. You may refer to the *Identifying the Inverter* section on page 25 for more details.
- The next three numbers represent the firmware versions of various processors.

**NOTE:**

Please have these numbers ready when you contact SolarEdge support.

- 5** Select the **5. Communication** option to define and configure the communication option used by the inverter to communicate with the SolarEdge Monitoring Server.

```

* 1 .   S e r v e r   < L A N >
  2 .   L A N   C o n f
  3 .   R S 4 8 5   C o n f
  4 .   Z i g B e e   C o n f

```

- Select option **5.1. Server** to select which communication method is used to communicate between this inverter and the SolarEdge Monitoring Portal.

- Select options **5.1.1**, **5.1.2**, **5.1.3** or **5.1.4** to configure the communication method to the SolarEdge Monitoring Portal. Refer to *Chapter 6, Setting Up Communication* on page 50 for a full description of these communication options:

You can also select the **5.1.5 None** option if no server communication is required.

**NOTE:**

This menu shows only the actual communication options installed in the inverter, based on the ordering options selected. If a communication option is not installed in the inverter, the relevant number does not appear in the menu.

- 6** Select the **6. Counters** option to reset all telemetry counters that are displayed in the *Energy Meter* window, which is described in the *Energy Meter Window* section on page 64.

```
T h i s   a c t i o n   w i l l  
R e s e t   a l l   c o u n t e r s  
  
P l e a s e   S e l e c t : N O
```

- 7** Select the **8. Info** option to display the Printed Circuit Board ID and the inverter's firmware version numbers.
- 8** Select the **9. Factory Reset** to perform a general reset of the inverter to its default settings.

Configuring the Inverter Using the SolarEdge Configuration Tool

Two options are provided for configuring the system:

- Using the LCD panel, as described in this guide.
- Using the SolarEdge configuration tool, which provides a standard Windows GUI. This tool can be accessed by connecting a computer or laptop to the inverter through the RS232 connector.

This tool provides several additional options than are not accessible using the LCD manual, such as enabling a firmware upgrade of the inverter and retrieving a list of the serial numbers of the power optimizers connected to the inverter for quickly verifying that all power optimizers have been installed properly. You may refer to the *SolarEdge Configuration Tool Software Guide*.



Appendix A

Errors and Troubleshooting

About This Appendix

The inverter LCD panel displays a message when an error occurs.

This appendix lists the error messages that may appear on the inverter's LCD panel, describes their meaning and describes how to troubleshoot each one.

Each message may comprise up to two lines of 20 characters each. The following shows the format of an error message on the inverter LCD panel:

```
E r r o r   c o d e   X X X  
X X X X X X X X X X X X X X X X X X X X  
X X X X X X X X X X X X X X X X X X X X
```

Each error message is displayed for 30 seconds. If the error no longer exists, the inverter displays the Waking Up message.

The following table lists the error messages that appear on the inverter and describes how to troubleshoot each one.

Error #	LCD Message	Description	Troubleshooting
9	AC Current Surge	The internal hardware that measures AC current has measured substantially high output currents. This may occur because of changes in the AC voltage or a switching load near the site.	<p>If this fault persists:</p> <ul style="list-style-type: none"> ▪ Check the AC connection to the inverter. ▪ Ask the grid operator whether a large surge source or irregular load exists near the site.
10	Ground Current - RCD	Ground current surge. The internal hardware that measures ground fault has measured substantially high ground currents.	<p>Ground faults may occur due to insufficient insulation to the ground.</p> <p>DO NOT TOUCH UN-INSULATED WIRES!</p> <p>EXTREME CARE MUST BE TAKEN WHEN TROUBLESHOOTING THIS ERROR.</p> <p>THE RISK OF ELECTROCUTION EXISTS!</p> <ul style="list-style-type: none"> ▪ Only a qualified technician should handle this problem, and only after taking proper precautions. ▪ Shut OFF the inverter by turning the ON/OFF switch at the bottom of the inverter OFF and disconnecting the AC switch. ▪ Wait five minutes for the input capacitors to discharge. ▪ Disconnect the DC inputs. ▪ For each DC string, measure the DC voltage between DC- and GND and DC+ and GND with a 1Kohm resistor in parallel to the volt meter. If a voltage higher than 2 V is measured, then the fault is in this string. ▪ Do not connect strings with a grounding fault to the inverter. ▪ A certified PV installer must fix the faulty string before connecting it to the inverter.

Error #	LCD Message	Description	Troubleshooting
13	AC Current Surge	AC current surge. The internal hardware that measures AC current has measured substantially high output currents. This may occur because of changes in the AC voltage or a switching load near the installation site.	<p>If this fault persists:</p> <ul style="list-style-type: none"> ▪ Check the AC connection to inverter. ▪ Ask the grid operator whether a large surge source or irregular load exists near the installation site. ▪ If the grid does not have problems contact SolarEdge support.
14	AC Voltage Too High	AC voltage surge. The internal hardware that measures AC voltage has measured substantially high instantaneous output voltage.	<p>If this fault persists:</p> <ul style="list-style-type: none"> ▪ Check the AC connection to inverter. ▪ Ask the grid operator whether a large surge source or irregular load exists near the site. ▪ Verify that the output wire size matches the distance between the inverter and the location of the grid connection. ▪ Use a larger gauge wire for the AC output.
15	DC Voltage Too High	DC overvoltage. The input DC voltage exceeds the maximum level that is supported.	<p>The SolarEdge system should normally eliminate DC overvoltage errors. When DC overvoltage is detected, the inverter shuts off the power optimizers and restarts the inverter.</p> <p>If the problem persists, then:</p> <ul style="list-style-type: none"> ▪ Turn OFF the ON/OFF switch at the bottom of the inverter. After at least five minutes, the LCD panel should show a low safety voltage equal to 1 V *string length. Otherwise, check which string is malfunctioning and recheck its connections to the inverter. ▪ Verify that no PV modules are connected directly to the inverter without a power optimizer. ▪ Recommission all inverters in the site, as described in <i>Chapter 4, Commissioning the Installation</i> on page 37.
16	Hardware Error	Internal hardware error.	<p>If the problem persists, contact SolarEdge support.</p>

Error #	LCD Message	Description	Troubleshooting
17	Temperature Too High	Over temperature.	<p>If the problem persists, then:</p> <ul style="list-style-type: none"> ▪ Verify that proper ventilation clearance exists around the inverter, as described in the <i>Chassis Clearance</i> section on page 26. ▪ Make sure that the heat-sink fins are clear of dirt and obstacles. ▪ Check whether the inverter is installed in an area that is too hot. ▪ Reinstall in a cooler location.
24	Faulty Temp. Sensor	Broken or unconnected Temperature sensor.	If the problem persists, contact SolarEdge support.
25	Isolation Fault	PV Isolation fault. The inverter has detected the PV solar generator is not properly isolated from ground earth. The isolation is checked every time before the inverter starts operation.	<p>If the problem persists:</p> <ul style="list-style-type: none"> ▪ Check the PV installation for isolation problems and ground leakage. ▪ Only a certified PV installer must fix the faulty string before connecting it to the inverter.
26	Faulty AC Relay	The AC relay failed during wake-up tests.	<p>If the problem persists:</p> <ul style="list-style-type: none"> ▪ Disconnect inverter from AC grid. ▪ Contact SolarEdge support.
27	Hardware Error	Internal hardware error.	If the problem persists, contact SolarEdge support.
28	RCD Sensor Error	The RCD measurement mechanism has failed during the wake-up test phase.	If the problem persists, contact SolarEdge support.
29-30	Phase Balance Error	The monitoring hardware that checks the balance of each phase (L1-N and L2-N) has exceeded its limit. This error is checked only in the USA.	<ul style="list-style-type: none"> ▪ Check the grid connection. ▪ Check the GND wire connection. ▪ Check the L1, L2 and Neutral wire connections. ▪ Verify symmetric load between L1 and L2. ▪ Consult the local grid authority.

Error #	LCD Message	Description	Troubleshooting
31	AC Voltage Too High	Grid voltage is above the limit permitted in this country.	<ul style="list-style-type: none"> ▪ Turn off the inverters in the site and verify AC grid voltage. ▪ If the inverter is located far from the connection point to the grid, then use a wider gauge AC wire. ▪ Consult the grid operator. ▪ If you are permitted by the local authorities, then use the SolarEdge Configuration Tool to change the range. Refer to the <i>SolarEdge Installation Tool User Guide</i> for mode detail.
32	AC Voltage Too Low	Grid Voltage is below the limit permitted in this country.	<ul style="list-style-type: none"> ▪ Consult the grid operator. ▪ If you are permitted by the local authorities, then use the SolarEdge Configuration Tool to change the settings. Refer to the <i>SolarEdge Installation Tool User Guide</i> for more detail.
33	AC Voltage Too High	Grid voltage is above the limit permitted in this country.	<ul style="list-style-type: none"> ▪ Handle this in the same manner as error 31.
34	AC Freq Too High	Grid frequency is above the limit permitted in this country.	<ul style="list-style-type: none"> ▪ Consult the grid operator. ▪ If you are permitted by the local authorities, then use the SolarEdge Configuration Tool to change the settings. Refer to the <i>SolarEdge Installation Tool User Guide</i> for more detail.
35	AC Freq Too Low	Grid frequency is below the limit permitted in this country.	<ul style="list-style-type: none"> ▪ Consult the grid operator. ▪ If you are permitted by the local authorities, then use the SolarEdge Configuration Tool to change the settings. Refer to the <i>SolarEdge Installation Tool User Guide</i> for more detail.
36	DC Injection	DC feed detected on the AC output.	<ul style="list-style-type: none"> ▪ If the problem persists, contact SolarEdge support.
37-38	Ground Current - RCD	Ground current surge. The internal hardware that measures ground fault has measured substantially high ground currents.	Handle this in the same manner as error 10.

Error #	LCD Message	Description	Troubleshooting
40	Islanding	AC grid voltage malfunctions. The inverter has shut off due to islanding.	When AC voltage returns the inverter should restart after some time (time depends on country grid connection codes) If the problem persists, then consult with the grid operator whether frequent AC disruptions have occurred at the site.
41	AC Voltage Too Low	Grid voltage is below the limit permitted. This error is checked only in the USA.	Handle this in the same manner as error 32.
43	Internal HW Error	Internal hardware error.	If the problem persists, contact SolarEdge support.
44	No Country Selected	The inverter is not configured to any country.	Select the country, as described on page 71.
4, 5, 8, 12, 18-23, 39, 42, 45	SW Error	Internal software error.	If this fault persists, contact SolarEdge support.
46	Phase Unbalance		Change the 7. Power Balance option in the Inverter's LCD menu to Disable .
82	Fan Maintenance	Fan replacement is required. The error message indicates which fan.	Replace the fan as described in the <i>Replacing the Fans</i> section on page 48.

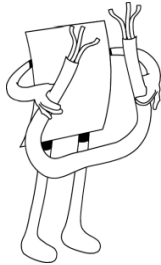

Appendix B

Technical Specifications

About This Appendix

The table in this appendix provides the technical specifications of the SolarEdge system components.

Three Phase Inverter

	SE7k	SE8k	SE9k	SE10k	SE12.5k	
Output						
Rated AC Power Output	7000	8000	9000	10000	12500	VA
Maximum AC Power Output	7000	8000	9000	10000	12500	VA
AC Output Voltage – Line to Line / Line to Neutral (Nominal)	380/220; 400/230					Vac
AC Output Voltage Range	184 – 265					Vac
AC Frequency	50/60 ± 5					Hz
Maximum Continuous Output Current (per Phase)	11.5	13.5	15.5	17.5	19.5	A
Total Harmonic Distortion (THD) at Maximum Power	< 3					%
Power Factor	> 0.99					
Residual Current Detector / Residual Current Step Detector	300 / 30					mA
Maximum DC Injection	130					mA
Grid Supported – Three Phase	3 / N / PE ; 230 / 400					V
Utility Monitoring, Islanding Protection, Country Configurable Thresholds	Yes					

SolarEdge Installation Guide for Three Phase Inverters – EU – Version 1.5

	SE7k	SE8k	SE9k	SE10k	SE12.5k	
Input						
Recommended Maximum DC Power (Module STC)	7700	8800	9900	11000	13000	W
Transformer-less, Ungrounded	Yes					
Maximum Input Voltage	950					Vdc
Nominal DC Input Voltage	750					Vdc
Maximum Input Current	14	15.5	20	18.5	22	Adc
Reverse-Polarity Protection	Yes					
Ground-Fault Isolation Detection	600 kΩ Sensitivity					
Maximum Inverter Efficiency	98					%
European Weighted Efficiency	97.7	97.6	97.6	97.5	97.4	%
Nighttime Power Consumption	< 2.5					W
Standards Compliance						
Safety	IEC-62103 (EN50178), Draft IEC-62109, UL1741					
Grid Connection Standards	VDE 0126-1-1, AS-4777, RD-1663, DK 5940, IEEE1547, NEC					
Emissions	IEC61000-6-2, IEC61000-6-3, IEC61000-3-11, IEC61000-3-12, FCC part15 class B					
WEEE, RoHS	Yes					
Installation Specifications						
AC Output	Cable Gland - diameter 13-18					mm
DC Input	MC4 compatible					
Maximum Installation Height	2000					m
Dimensions (W x L x H)	540 x 315 x 260					mm
Weight	32					kg
Operating Temperature Range	-20 – +60					°C
Cooling	Fan (user replaceable)					
Protection Rating	IP65 – Outdoor and Indoor					
Bracket Mounted (Bracket Provided), Optional Attachable Cabling Duct (EU), Integral DC Switch (US)						

OP250-LV, OP300-MV and OP400-MV

	OP250-LV	OP300-MV/OP400-MV	
Input			
Rated Input DC Power	250	300/400	W
Absolute Maximum Input Voltage	55	75	Vdc
MPPT Operating Range	5 – 55	5 – 75	Vdc
Maximum Input Current	10		Adc
Reverse-Polarity Protection	Yes		
Maximum Efficiency	99.5		%
European Weighted Efficiency	98.8		%
CEC Weighted Efficiency	98.7		%
Nighttime Power Consumption	0		W
Overvoltage Category	II		
Output During Operation (Power Optimizer Connected to Operating Inverter)			
Maximum Output Current	15		Adc
Operating Output Voltage	5 – 60		Vdc
Total Maximum String Voltage (Controlled by Inverter) - US and EU 1-ph	550		Vdc
Total Maximum String Voltage (Controlled by Inverter) - EU 3-ph	950		Vdc
Output During Standby (Power Optimizer Disconnected from Inverter or Inverter Off)			
Safety Output Voltage per power optimizer	1		Vdc
PV System Design			
Minimum Number of power optimizers per String (1 or More Modules per power optimizer)	8 (1-ph system) / 15 (3-ph system)		
Maximum Number of power optimizers per String (1 or More Modules per power optimizer)	Module power dependent; typically 20 - 25 (1-ph system) 45 - 50 (3-ph system)		
Parallel Strings of Different Lengths or Orientations	Yes		
Standard Compliance			
EMC	FCC Part15 Class B, IEC61000-6-2, IEC61000-6-3		
Safety	IEC-62103 (class II safety), UL1741		
Material	UL-94 (5-VA), UV Resistant		
RoHS	Yes		

	OP250-LV	OP300-MV/OP400-MV	
Installation Specifications			
Dimensions (W x L x H)	120 x 130 x 37 / 4.72 x 5.11 x 1.45		mm / in
Weight	450 / 1.0		g / lb
Maximum Installation Height	2000m		
Output PV Wire	0.95 m / 3 ft length ; 6 mm ² ; MC4		
Input Connector	MC4 / MC3 / Tyco / H+S / Amphenol – H4 / LC4 / LC3		
Operating Temperature Range	-40 – +65 / -40 – +150		°C / °F
Protection Rating	IP65 / NEMA 4		
Relative Humidity	0 – 100		%

PB250-AOB and PB350-AOB

Input		
Rated Input DC Power	250	W
Absolute Maximum Input Voltage	60 (*)	Vdc
MPPT Operating Range	5 – 60	Vdc
Maximum Input Current	10	Adc
Reverse-Polarity Protection	Yes	
Maximum Efficiency	98.6	%
European Weighted Efficiency	97.8	%
CEC Weighted Efficiency	97.7	%
Inductive Lightning Protection	1 / 3	m / ft
Nighttime Power Consumption	0	W
Output During Operation (Inverter is Operating)		
Maximum Output Current	15	A
Operating Output Voltage	5 – 60	V
Total Maximum String Voltage (Controlled by Inverter) - US and EU 1-ph	600	V
Total Maximum String Voltage (Controlled by Inverter) - EU 3-ph	1000	V
Output During Standby (Inverter is Disconnected or Off)		
Safety Output Voltage per Optimizer	1	Vdc

PV System Design		
String Limitations - EU, 1ph System	8 – 25	Modules
String Limitations - EU, 3ph System	16 – 50	Modules
String Limitations - US	8 – 25	Modules
Parallel Strings of Different Lengths or Orientations	Yes	
Standard Compliance		
EMC	FCC Part15 Class B, IEC61000-6-2, IEC61000-6-3	
Safety	UL1741, IEC-62103 (class II safety), IEC61730	
Material	UL-94 (5-VA), UV Resistant	
WEEE, RoHS	Yes	
Installation Specifications		
Dimensions (W x L x H)	149.5 x 142 x 27.2 / 5.9 x 5.6 x 1.1	mm / in
Weight	800 / 1.8	g / lb
Maximum Installation Height	2000m	
Operating Temperature Range	-40 – +65 / -40 – +150	°C / °F
Protection Rating	IP65 Outdoor Use / NEMA 3R	
Relative Humidity	0 - 100	%

(*) TFI version up to 100V

PB250-TFI and PB350-TFI Power Optimizer

Input		
Rated Total Input DC Power	350	W
Number of Input Panels (Parallel Connection)	2 - 4	
Absolute Maximum Input Voltage	100	Vdc
Maximum Current per Input	2 / 3	Adc
Fuse Inputs	Optional	
MPPT Operating Range	10 - 95	Vdc
Reverse-Polarity Protection	Yes	
Maximum Efficiency	98.6	%
European Weighted Efficiency	97.8	%

SolarEdge Installation Guide for Three Phase Inverters – EU – Version 1.5

CEC Weighted Efficiency	97.7	%
Inductive Lightning Protection	1 / 3	m / ft
Nighttime Power Consumption	0	W
Output During Operation (Inverter is Operating)		
Maximum Output Current	15	A
Operating Output Voltage	5 - 60	V
Total Maximum String Voltage (Controlled by Inverter) - US and EU 1-ph	600	V
Total Maximum String Voltage (Controlled by Inverter) - EU 3-ph	1000	V
Output During Standby (Inverter is Disconnected or Off)		
Safety Output Voltage per power optimizer	1	Vdc
PV System Design		
String Limitations – EU, 1ph System	8 – 25	Power Optimizers
String Limitations – EU, 3ph System	16 – 50	Power Optimizers
Parallel Strings of Different Lengths or Orientations	Yes	
Standard Compliance		
EMC	FCC Part15 Class B, IEC61000-6-2, IEC61000-6-3	
Safety	UL1741, IEC-62103 (class II safety), IEC61730	
Material	UL-94 (5-VA), UV Resistant	
WEEE, RoHS	Yes	
Installation Specifications		
Dimensions (W x L x H)	149.5 x 142 x 27.2 / 5.9 x 5.6 x 1.1	mm / in
Weight	800 / 1.8	g / lb
Maximum Installation Height	2000m	
Operating Temperature Range	-40 - +65 / -40 - +150	°C / °F
Protection Rating	IP65 Outdoor Use / NEMA 3R	
Relative Humidity	0 - 100	%

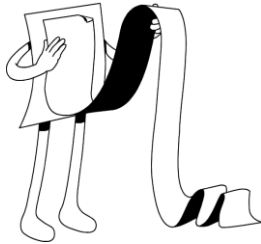

Appendix C

Power Optimizer Mechanical Specifications

About This Appendix

This appendix presents the mechanical specifications for the SolarEdge power optimizers.

Use M8 screws and washers to secure the power optimizer units to the racking.

**NOTE:**

SolarEdge does not provide the screws, nuts or washers because the required sizes and lengths vary for different racks.

**CAUTION:**

Before installing directly on the module or module frame, first consult the module manufacturer for information about the proper positioning and its impact on the module warranty.

- Mark all mounting hole locations.
- Each power optimizer must be attached to the rack using both mounting holes.
- Drill the holes.

**CAUTION:**

Do not drill through the power optimizer or through the mounting holes. The strong vibrations created by the drill can damage the power optimizer.

OP250-LV, OP300-MV, OP400-MV Power Optimizers

The following figure shows the mechanical specifications for the OP250-LV, OP300-MV, OP400-MV, power optimizers:

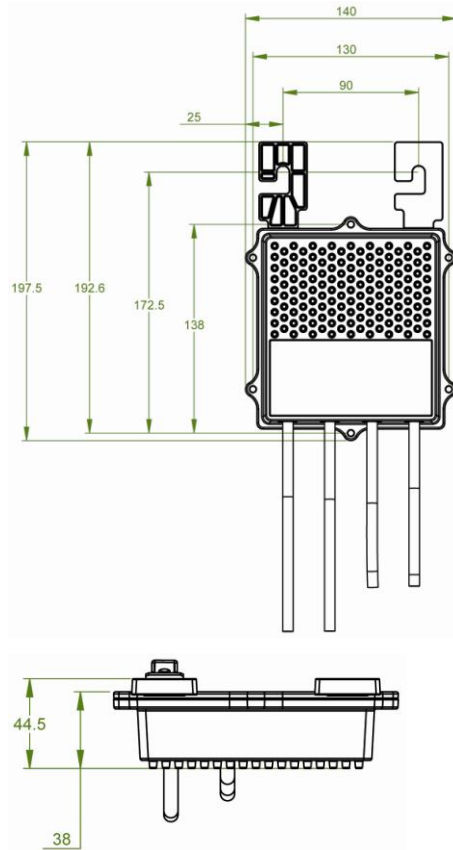

Figure 31: Power Optimizer Mechanical Specifications

PB250-AOB and PB350-AOB Power Optimizers

The following figure shows the mechanical specifications for the PB250-AOB and PB350-AOB power optimizers:

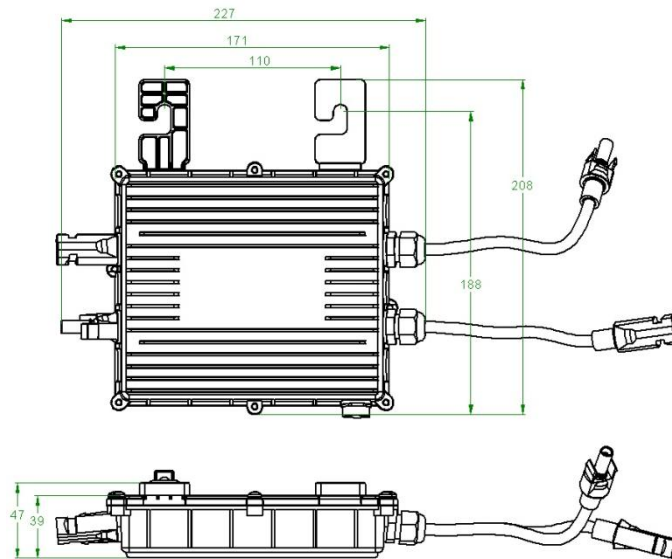

Figure 32: PB250-AOB and PB350-AOB power optimizer Mechanical Specifications

PB250-TFI and PB350-TFI Power Optimizer

The following figure shows the mechanical specifications for the PB250-TFI and PB350-TFI power optimizers:

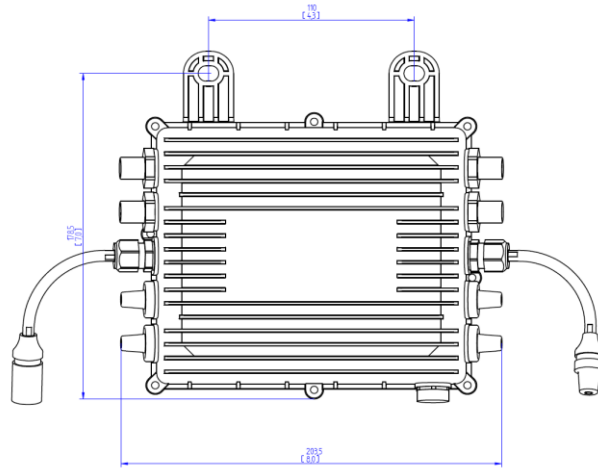

Figure 33: PB250-TFI and PB350-TFI Power Optimizer Mechanical Specifications



If you have technical problems concerning our products,
please contact us:

USA & Worldwide Support Line: +1.650.319.8843

Germany: +49.89.4161703-30

France: +33.(0)970.465.662

Israel: +972.73.2403118

Fax: +972.73.2403117

Email to: support@solaredge.com

www.solaredge.com

solaredge
architects of energy™



MAN - 01 - 00016 - A1 . 5