

SAPPHIRESOLAR  
*Power Yourself*

# INSTALLATION MANUAL CRYSTALLINE SOLAR MODULE



Sapphire Solar Pty Ltd

Phone: 1300 308 751

Email: [info@sapphire-solar.com](mailto:info@sapphire-solar.com)

Level 1/ 308 Kororoit Creek Rd, Williamstown North, VIC, 3016



## TABLE OF CONTENTS

1. DISCLAIMER OF LIABILITY .....	3
2. SAFETY PRECAUTIONS .....	3
3. UNPACKING AND STORAGE .....	4
3.1 PRODUCT IDENTIFICATION.....	4
4. ENVIRONMENTAL CONSIDERATIONS.....	4
4.1 CLIMATE CONDITIONS.....	4
5. SITE SELECTION.....	5
6. MOUNTING INSTRUCTIONS.....	6
6.1 MOUNTING METHODS.....	6
6.2 MODULE TILT ANGLE.....	9
6.3 GROUNDING.....	9
6.4 MODULE WIRING .....	9
7. ELECTRICAL CONFIGURATION.....	11
7.1 FUSING .....	11
7.2 INVERTER SELECTION AND COMPATIBILITY.....	11
8. MAINTENANCE AND CARE.....	11
9. WARNING.....	12
10. CONTACT AND FEEDBACK.....	12



## 1. DISCLAIMER OF LIABILITY

The installation, handling and use of Sapphire Solar crystalline modules are beyond company control. Sapphire Solar does not assume any responsibility for loss, damage, injury or expense resulting from the improper installation, handling, use or maintenance.

Sapphire Solar assumes no responsibility for any infringement of patents or other rights of third parties that may result from use of the module. No license is granted by implication or under any patent or patent rights.

Specifications are subject to change without prior notice.

## 2. SAFETY PRECAUTIONS

- Potentially lethal DC voltages can be generated whenever PV Modules are exposed to a light source, avoid contact with electrically active parts and be sure to isolate live circuits before attempting to make or break any connections.
- Only authorized and trained personnel should have access to or perform work on the modules or solar system.
- When working on electrical connections, remove all metallic jewelry, use properly insulated tools and wear appropriate personal protective equipment to reduce the risk of electric shock.
- Do NOT stand or step on, damage or scratch the front or backside surfaces of the module.
- Broken modules cannot be repaired and contact with any module surface or frame can lead to electrical shock. Do NOT use a module with broken glass or torn substrate.
- Do NOT disassemble the modules or remove any part of the module.
- Protect the electrical plug contacts against corrosion and soiling. Make sure that all connectors are corrosion free and clean before making the connection.
- Do NOT install or handle modules when they are wet or during periods of high wind.
- Ensure that all connections are securely made with no gap between the contacts. Any gap can result in electrical arcing that can cause a fire hazard and/or an electric shock.
- Make sure that the polarity of each module or a string is not reversed considering the rest of the modules or strings.
- Do NOT artificially concentrate sunlight on these solar modules.
- Sapphire Solar modules are certified for operating in Class A installations at voltages below 1000Vdc. This maximum voltage should not be exceeded at any time and, as the voltage of the module increases, above data sheet values, at operating temperatures below 25°C, then these need to be taken into account when designing a PV system.
- Do NOT use water to extinguish fires of an electrical origin.
- Under normal conditions, a solar photovoltaic module is likely to produce more current and /or voltage



than reported under standard test conditions. Accordingly, the value of  $I_{sc}$  marked on this module should be multiplied by a factor of 1.25 when determining the conductor current ratings, fuse sizes and size of controls connected to the SPV output.

### **3. UNPACKING AND STORAGE**

- At time of receipt, verify that the product delivered is in fact the product order. The product name, sub-name, and serial number of each are clearly marked on the outside of each packing box.
- When transporting the product between sites, leave it in its original packing box (standing vertically) until you are ready to install.
- Store packing boxes in a clean, dry area with relative humidity below 85% and ambient temperatures between  $-20^{\circ}\text{C}$  and  $50^{\circ}\text{C}$ .
- Do NOT stack packing boxes (pallets) more than 2 boxes high.
- At the installation site, take care to keep modules and, in particular, their electrical contacts clean and dry before installation. If connectors are left in damp conditions then the contacts may corrode. Any module with corroded contacts should not be used.
- If pallets are stored temporarily outside then place a protective covering over the pallet to protect it from direct weathering and do not stack more than 1 pallet high.
- Two people are required to unpack the modules from the packing box, when handling modules with suitable wire cutting pliers and take care to avoid scratches to the module back surface.
- Do NOT place modules directly on top of each other.

#### **3.1 PRODUCT IDENTIFICATION**

Each individual module has a unique serial number laminated behind the glass and another permanently attached to the backsheet of the module on the product sticker. Note all serial numbers in an installation for your future records.

### **4. ENVIRONMENTAL CONSIDERATIONS**

#### **4.1 CLIMATE CONDITIONS**

Sapphire Solar crystalline series modules may be installed in the following conditions for more than 25 years. In addition to the required IEC certification to meet European standards Sapphire Solar products have also been tested to verify resistance to ammonia fumes that may be present around barns sheltering cattle, as well as suitability for installation in humid (coastal) areas and areas of high sand storms.

Environment

- Ambient temperature:  $-40^{\circ}\text{C}$  to  $+50^{\circ}\text{C}$ .



- ï Operating temperature: -40°C to +85°C.
- ï Storage temperature: -20°C to +50°C.
- ï Humidity: < 85RH%
- ï Mechanical Load Pressure\*: 5400Pa (550 Kg/m<sup>2</sup>) Max from the front side (snow) & 200KM/Hour (wind) from the rear.

\* Notes:

- The modules have been evaluated by TUV according to IEC61215 for a maximum design loading of below (5400Pa)
- The mechanical load bearing is dependent upon the mounting methods used and failure to follow the instructions of this manual may result in different capabilities to withstand snow and wind loads. The system installer must ensure that the installation methods used meet these requirements and any local codes and regulations.

## 5. SITE SELECTION

- Sapphire Solar modules can be mounted in landscape or portrait orientation.
- For optimum energy production, solar modules should normally be mounted facing the equator at an angle to the horizontal plane equivalent to the latitude of the installation. In the event that you mount the solar modules at a different angle or orientation then the annual energy production may potentially be adversely impacted.
- When installing solar modules on a roof always leave a safe working area between the edge of the roof and the external edge of the solar array.
- Position the modules to minimize the chances of shading at any time of the day. Shading can normally be minimized by ensuring that the distance between the obstruction and solar array is greater than three times the obstruction's height.
- Any slope of less than 1: 2.4 is required to maintain the fire class rating.
- Avoid using a mounting method that will block the drainage holes in the module frame.
- When all solar modules are mounted in the same plane and orientation then all can be expected to have similar performance throughout the day and can be connected together to the same inverter channel.
- If solar modules on the same installation are mounted at different angles or orientations then energy production can normally be optimized by connecting the different orientations to different inverters (or different MPPT if the inverter has more than one MPPT). Refer to inverter manufacturers for further guidelines.
- Do not install SPV modules in a location where they will be immersed in or continually exposed to water.
- According to TUV Rheinland-conducted testing of 2 PFG 1917/05.11 "Ammonia corrosion testing of



photovoltaic (PV) modules” and DLG Fokus testing for ammonia resistance, Sapphire Solar modules can be safely installed in ammonia-heavy environments, such as farm houses.

## 6. MOUNTING INSTRUCTIONS

### 6.1 MOUNTING METHODS

PV modules can be mounted to the substructure using either corrosion-proof M8 bolts placed through the mounting holes on the rear of the module or specially designed module clamps.

Regardless of the fixing method the final installation of the modules must ensure that:

- A clearance of at least 115mm is provided between modules frame and the surface of the wall or roof.
- The minimum distance between two modules is 10 mm.
- The mounting method does not block the module drainage holes.

Panels are not subjected to wind or snow loads exceeding the maximum permissible loads, and are not subject to excessive forces due to the thermal expansion of the support structures.

#### *A. Fixing With Bolts*

The frame of each module has 4 x  $\phi$ 9mm mounting holes, ideally placed to optimize the load handling capability, to secure the modules to supporting structure.

- To maximize mounting longevity, Sapphire Solar strongly recommends the use of corrosion proof (stainless steel) fixings
- Secure the module in each fixing location with an M8mm bolt and a flat washer, spring washer and nut as shown in Figure 1 and tighten to a torque of 16 Nm.

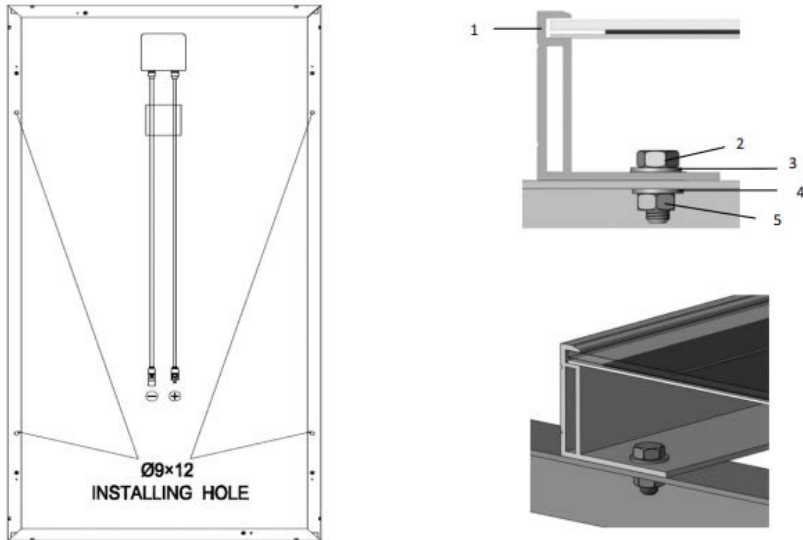

**Figure 1. Sapphire Solar module installed with Screw fitting method**

- |                            |                       |                          |
|----------------------------|-----------------------|--------------------------|
| 1) Aluminum frame          | 2) M8 stainless screw | 3) Flat stainless washer |
| 4) Spring stainless washer | 5) HEX stainless nut  |                          |

#### *B. Clamp Fixing*

- Sapphire Solar have tested our modules with a number of clamps from different manufacturers and recommend the use of clamps which have an EPDM or similar insulating washer, fixing screw of at least 6mm. The clamp must overlap the module frame by at least 7mm, but no more than 10 mm.
- Use at minimum four clamps to fix modules on the mounting rail.
- Module clamps should not come into contact with the front glass and must not deform the frame.
- Be sure to avoid shadowing effects from the module clamps.
- The module frame is not to be modified under any circumstances.
- When choosing this type of clamp-mounting method, use at least four clamps on each module, two clamps should be attached on each long side of the module (for portrait orientation) and each short sides of the module (for landscape orientation). Depending on local wind and snow loads, additional clamps may be required to ensure modules can bear the load.
- Applied torque should be 8 Nm. Please find detailed mounting information in the illustration below:

Fringe modules installation

Middle modules installation

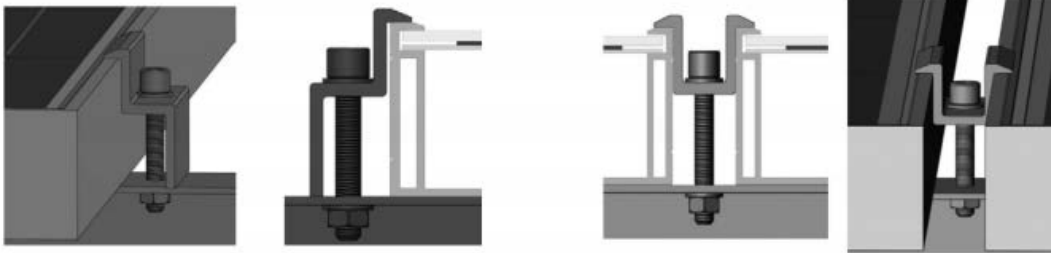
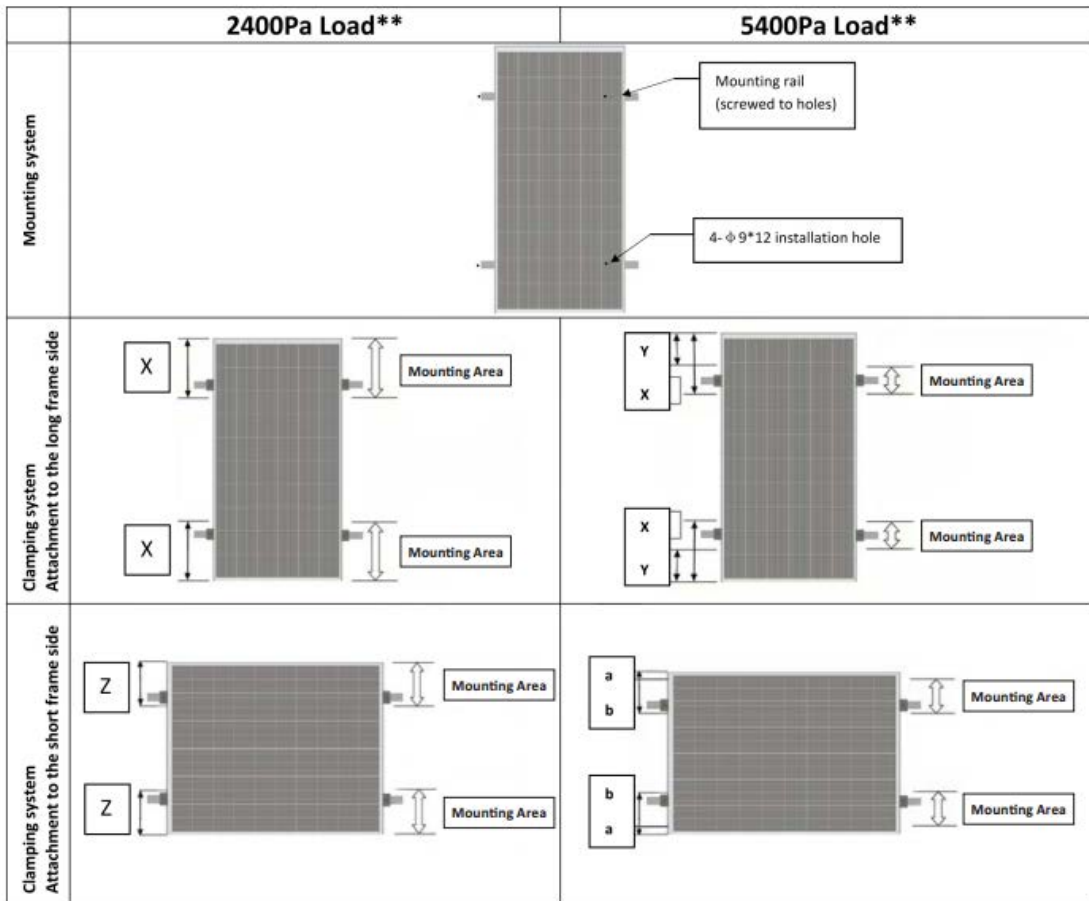

Figure2. Sapphire Solar module installed with clamp fitting method\*



Dimension on module size :

Panel Type	Product Style No	Length (mm)	Width (mm)	a (mm)	B (mm)	X (mm)	Y (mm)	Z (mm)
5" 72 pcs Mono	SS***M/72	1580	808	38	153	395	198	191



6" 60 pcs Multi	SS***P/60	1640	992	47	188	413	206	235
6" 60 pcs Mono	SS***M/60	1640	992	47	188	413	206	235
6" 72 pcs Multi	SS***P/72	1950	992	47	188	489	245	235
6" 72 pcs Mono	SS***M/72	1950	992	47	188	489	245	235

## 6.2 MODULE TILT ANGLE

Sapphire solar modules produce the most power when they are pointed directly at the sun. For installations where the solar modules are attached to a permanent structure, the solar modules should be tilted for optimum winter performance. As a rule, if the system power production is adequate in the winter, it will be satisfactory during the rest of the year. The module tilt angle is measured between the solar modules and the ground (Figure 3). Refer to Table 1 for the recommended module tilt angle for your site

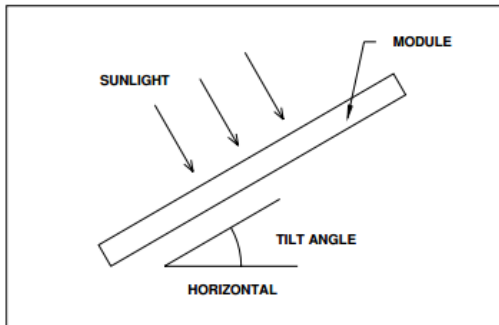

Figure 3

**Table 1. Recommended Tilt Angles for Fixed Systems—Based on Winter Performance**

SITE LATITUDE IN DEGREES	FIXED TILT ANGLE
0° TO 15°	15°
15° TO 25°	SAME AS LATITUDE
25° TO 30°	LATITUDE + 5°
30° TO 35°	LATITUDE + 10°
35° TO 40°	LATITUDE + 15°
40° +	LATITUDE + 20°

## 6.3 GROUNDING

- All module frames and mounting racks must be properly grounded in accordance with appropriate respective national electrical code.
- Proper grounding is achieved by bonding the module frame(s) and all metallic structural members together continuously using a suitable grounding conductor. The grounding conductor or strap may be copper, copper alloy, or any other material acceptable for use as an electrical conductor per respective National Electrical Codes. The grounding conductor must then make a connection to earth using a suitable earth ground electrode.
- Sapphire Solar modules can be installed with the use of third party listed grounding devices for grounding the metallic frames of PV modules. The devices have to be installed in accordance with the grounding device manufacturer's specified instructions.

## 6.4 MODULE WIRING

- All wiring should be performed, by qualified installers, in accordance with the local codes and regulations.
- Modules can be connected in series to increase the operating voltage by plugging the positive

plug of one module into the negative socket of the next until there is a “click”. Before connecting modules always ensure that the contacts are corrosion free, clean and dry.

- Product can be irreparably damaged if an array string is connected in reverse polarity to another. Always verify the voltage and polarity of each individual string before making a parallel connection. If you measure a reversed polarity or a difference of more than 10V between strings then check the string configuration before making the connection.
- Sapphire Solar modules are provided with stranded copper cables with a cross sectional area of 4mm<sup>2</sup> which are rated for 1000Vdc, 90°C and are UV resistant. All other cables used to connect the DC system should have a similar (or better) specification. Sapphire Solar recommend that all cables are run in appropriate conduits and sited away from areas prone to water collection.
- The maximum voltage of the system must be less than either the maximum certified voltage (1000V typically) or the maximum input voltage of the inverter and of the other electrical devices installed in the system. To ensure that this is the case, the open circuit voltage of the array string needs to be calculated at the lowest expected ambient temperature for the location. This can be done using the following formula.

$$\text{System voltage} = N * \text{Voc} * [1 + \text{TCvoc} * (25 - \text{Tmin})]$$

Where:

- N No modules in series
- Voc Open circuit voltage of each module (refer to product label or data sheet)
- TCvoc Thermal coefficient of open circuit voltage for the module (refer to data sheet)
- Tmin Minimum ambient temperature

- The minimum and maximum outer diameters of the cable are 5 to 7mm.
- For field connections, use at least 4mm<sup>2</sup> copper wires insulated for a minimum of 90°C and sunlight resistance with insulation designated as PV Wire.
- Minimum bending radius of our cables should be 43mm.

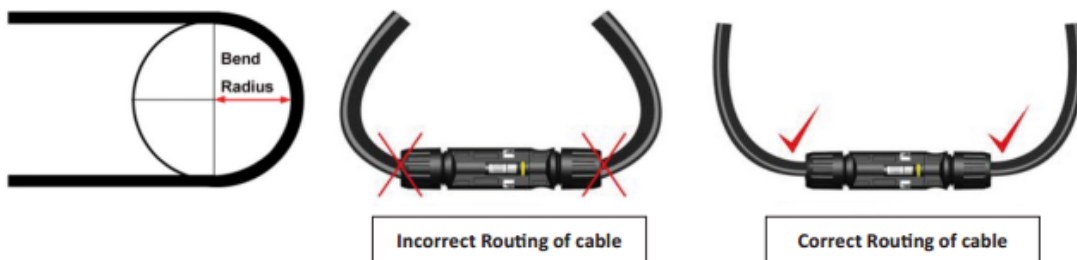



## 7. ELECTRICAL CONFIGURATION

Photovoltaic (electric) systems operate automatically and require very little day-to-day supervision. The solar array generates DC electricity whenever light falls on it, similarly the inverter automatically turns ON as soon as there is sufficient energy from the solar array to efficiently convert this into grid quality AC power.

Caution:

- The module is rated to operate at potentially lethal DC voltages which have the potential to cause severe electrical shock, arcing and fire hazards. Whilst most solar modules, manufactured by Sapphire Solar, are certified to operate up to 1000V dc always check the module label to confirm the actual rating of your product before making connections.
- Always use a suitably rated isolator (DC switch) to interrupt the current flow before disconnecting the connectors.

### 7.1 FUSING

When fuses are fitted they should be rated for the maximum DC voltage and connected in each, non-grounded pole of the array (i.e. if the system is not grounded then fuses should be connected in both the positive and negative poles).

The maximum rating of a fuse connected in series with an array string is typically 15A but the actual module specific rating can be found on the product label and in the product datasheet.

This fuse rating value also corresponds to the maximum reverse current that a module can withstand (when one string is shaded then the other parallel strings of modules will be loaded by the shaded string and current will flow) and therefore impacts the number of strings in parallel.

### 7.2 INVERTER SELECTION AND COMPATIBILITY

When installed in systems governed by IEC regulations, Sapphire Solar modules normally do not need to be electronically connected to earth and therefore can be operated together with either galvanically isolated (with transformer) and transformerless inverters. However, if the system is located in a hot, humid climate and the maximum voltage is greater than 600Vdc then galvanically isolated inverters incorporating a transformer must be used and the negative pole of the array must be connected to earth.

## 8. MAINTENANCE AND CARE

A well designed solar system requires minimal maintenance; however, system performance and reliability can be improved by taking some simple steps.

- Maintenance should be carried out at least once a year by trained personnel.



- Trim any vegetation which may shade the solar array thus impacting performance.
- Check that mounting hardware is properly tightened.
- Inspect all cables to verify that connections are tight; the cables are protected from direct sunlight and sited away from areas of water collection.
- Check that all string fuses in each non/earthed pole are operating.
- In the event that the solar modules need to be cleaned then clean the module use a soft cloth together with a mild detergent and clean water. Take care to avoid severe thermal shocks which might damage the module by cleaning modules with water which has a similar temperature to the modules being cleaned.
- The back surface of the module normally does not need to be cleaned but, in the event this is deemed necessary, avoid the use of any sharp projects that might damage the penetrating substrate material.

## **9. WARNING**

**For any electrical maintenance, the PV system must first be shut down. Improper maintenance can cause lethal electric shock and/or burns.**

## **10. CONTACT AND FEEDBACK**

If you suspect that your installation is not working properly, please contact us immediately.

Phone: 1300 308 751

Email: [info@sapphire-solar.com](mailto:info@sapphire-solar.com)

Address: Level 1, 308 Kororoit Ck Rd, Williamstown North, VIC, 3016