

1	SAFETY PRECAUTIONS	79
2	GENERAL INTRODUCTION	82
3	ACCESSORIES	83
4	BEFORE INSTALLATION	83
5	IMPORTANT INFORMATION FOR THE REFRIGERANT	84
6	INSTALLATION SITE	84
6.1	Selecting a location in cold climates	85
6.2	Selecting a location in hot climates	85
7	INSTALLATION PRECAUTIONS	85
7.1	Dimensions	86
7.2	Installation requirements	86
7.3	Drain hole position	87
7.4	Servicing space requirements	87
8	TYPICAL APPLICATIONS	88
8.1	Application 1	88
8.2	Application 2	90
8.3	Cascade system	93
8.4	Balance tank volume requirement	95
9	OVERVIEW OF THE UNIT	95
9.1	Disassembling the unit	95
9.2	Main components	96
9.3	Electronic control box	97
9.4	Water piping	105
9.5	Filling water	107
9.6	Water piping insulation	108
9.7	Field wiring	108
10	START-UP AND CONFIGURATION	123
10.1	DIP switch settings overview	123
10.2	Initial start-up at low outdoor ambient temperature	123
10.3	Pre-operation checks	123
10.4	The circulation pump	124
10.5	Field settings	125
11	TEST RUN AND FINAL CHECKS	134
11.1	Final checks	134
11.2	Test run operation (manually)	134
12	MAINTENANCE AND SERVICE	134
13	TROUBLE SHOOTING	134
13.1	General guidelines	134
13.2	General symptoms	135
13.3	Operation parameters	137
13.4	Error codes	138
14	TECHNICAL SPECIFICATIONS	142
14.1	General	142
14.2	Electrical specification	142
15	INFORMATION SERVICING	143

IMPORTANT NOTE:

Thank you very much for purchasing our product, Before using your unit, please read this manual carefully and keep it for future reference.



RANGE		
Code	Description	Power size
20191845	A2WHPR32M/004	4kW
20191846	A2WHPR32M/006	6kW
20191847	A2WHPR32M/008	8kW
20191848	A2WHPR32M/010	10kW

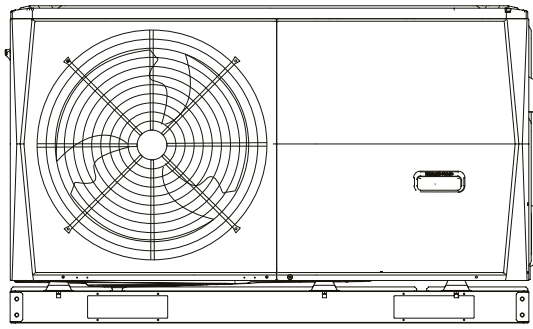

4/6 kW

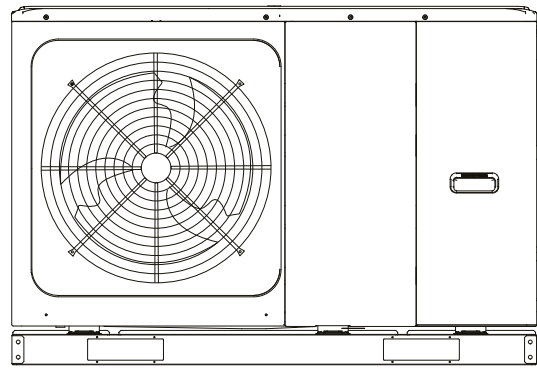

8/10/12/14/16 kW

Internal layout: 12~16kW(3-phase) for example

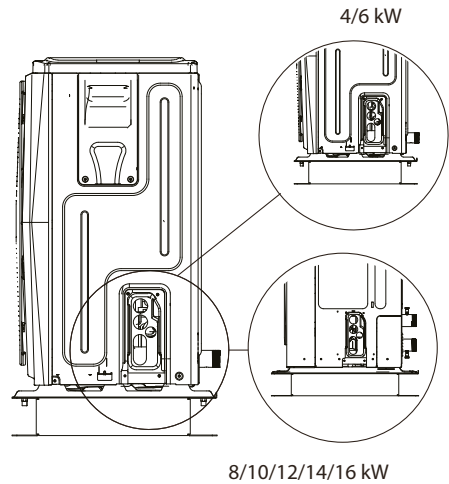
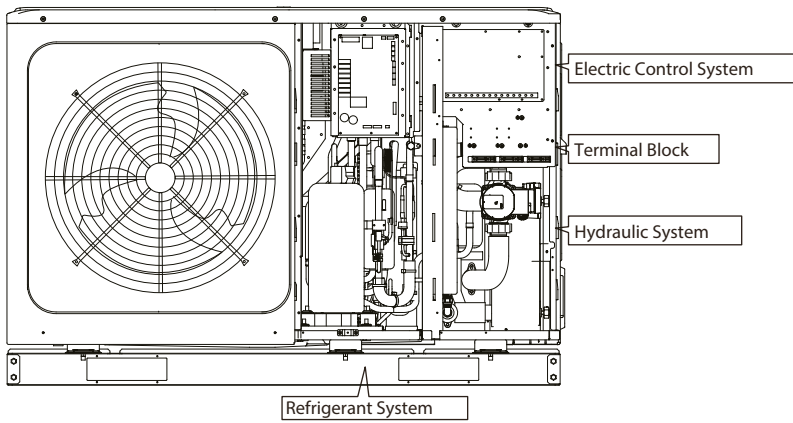

Please remove the hollow plate after installation.

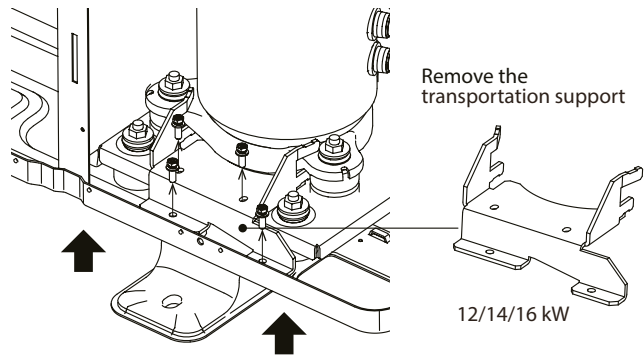
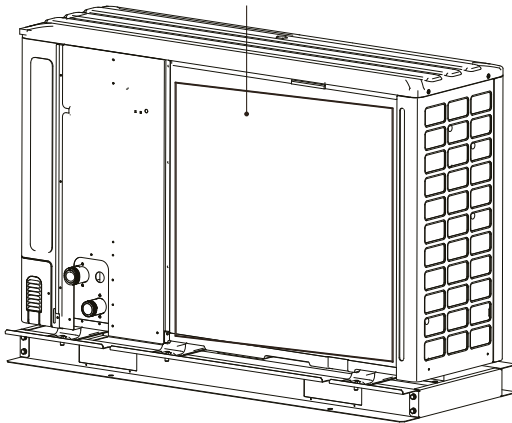

NOTE

Pictures in this manual are for reference only, please refer to the actual product.

Unit	1-phase							3-phase		
	4	6	8	10	12	14	16	12	14	16
Capacity of backup heater	3kW(1-phase)			3kW(1-phase) or 9kW(3-phase)						
	Backup heater (optional)									
The standard unit is without backup heater.										

1 SAFETY PRECAUTIONS

The precautions listed here are divided into the following types. They are quite important, so be sure to follow them carefully. Meanings of **DANGER**, **WARNING**, **CAUTION** and **NOTE** symbols.

INFORMATION

- Read these instructions carefully before installation. Keep this manual in a handy for future preference.
- Improper installation of equipment or accessories may result in electric shock, short-circuit, leakage, fire or other damage to the equipment. Be sure to only use accessories made by the supplier, which are specifically designed for the equipment and **make sure to get installation done by a professional.**
- All the activities described in this manual must be carried out by a licensed technician. Be sure to wear adequate personal protection equipment such as gloves and safety glasses while installing the unit or carrying out maintenance activities.
- Contact your dealer for any further assistance.



Caution: Risk of fire/
flammable materials

 **WARNING** Servicing shall only be performed as recommended by the equipment manufacturer. Maintenance and repair requiring the assistance of other skilled personnel shall be carried out under the supervision of the person competent in the use of flammable refrigerants.





 **DANGER** Indicates an imminently hazardous situation which if not avoided, will result in death or serious injury.

 **WARNING** Indicates a potentially hazardous situation which if not avoided, could result in death or serious injury.

 **CAUTION** Indicates a potentially hazardous situation which if not avoided, may result in minor or moderate injury. It is also used to alert against unsafe practices.

 **NOTE** Indicates situations that could only result in accidental equipment or property damage.

Explanation of symbols displayed on the monobloc

	WARNING	This symbol shows that this appliance used a flammable refrigerant. If the refrigerant is leaked and exposed to an external ignition source, there is a risk of fire.
	CAUTION	This symbol shows that the operation manual should be read carefully.
	CAUTION	This symbol shows that a service personnel should be handling this equipment with reference to the installation manual.
	CAUTION	This symbol shows that a service personnel should be handling this equipment with reference to the installation manual.
	CAUTION	This symbol shows that information is available such as the operating manual or installation manual.

Explanation of abbreviations used

Abbreviations	Definitions
T1	Total water outlet temperature of hydraulic module (after electrical heating outlet or gas boiler outlet)
T1S	Water outlet setting temperature (Single zone installation)
	Zone 1 outlet water setting temperature (Dual-zone installation)
T1S2	Zone 2 outlet water setting temperature (Dual-zone installation)
T2	Hydraulic module refrigerant liquid side temperature
T2B	Hydraulic module refrigerant gas side temperature
T5	Tank temperature
Tw_out	Plate heat exchanger outlet temperature
Tw_in	Plate heat exchanger inlet temperature
TW2	Zone 2 outlet temperature
T4	Outdoor environment temperature
PUMP I	Built-in water pump in hydraulic module
PUMP O	External water pump for single-zone system
	Zone water pump for dual-zone system
PUMP C	Zone 2 water pump for dual-zone system
PUMP S	Solar system water pump
PUMP D	Pipe net water return pump
IBH	Electric backup heater
TBH	Tank booster heater in DHW tank
AHS	External heat source
SV1	Three - way valve of DHW and air conditioning switching
SV2	Three - way valve, heating zone-cooling zone
SV3	Mixing valve for zone2 (low temperature zone)

DANGER

- Before touching electric terminal parts, turn off power switch.
- When service panels are removed, live parts can be easily touched by accident.
- Never leave the unit unattended during installation or servicing when the service panel is removed.
- Do not touch water pipes during and immediately after operation as the pipes may be hot and could burn your hands. To avoid injury, give the piping time to return to normal temperature or be sure to wear protective gloves.
- Do not touch any switch with wet fingers. Touching a switch with wet fingers can cause electrical shock.
- Before touching electrical parts, turn o all applicable power to the unit.

WARNING

- Tear apart and throw away plastic packaging bags so that children will not play with them. Children playing with plastic bags face danger of death by suffocation.
- Safely dispose of packing materials such as nails and other metal or wood parts that could cause injuries.
- Ask your dealer or qualified personnel to perform installation work in accordance with this manual. Do not install the unit yourself. Improper installation could result in water leakage, electric shocks or fire.
- Be sure to use only specified accessories and parts for installation work. Failure to use specified parts may result in water leakage, electric shocks, fire, or the unit falling from its mount.
- Install the unit on a foundation that can withstand its weight. Insufficient physical strength may cause the equipment to fall and possible injury.
- Perform specified installation work with full consideration of strong wind, hurricanes, or earthquakes. Improper installation work may result in accidents due to equipment falling.
- Make certain that all electrical work is carried out by qualified personnel according to the local laws and regulations and this manual using a separate circuit. Insufficient capacity of the power supply circuit or improper electrical construction may lead to electric shocks or fire.
- Be sure to install a ground fault circuit interrupter according to local laws and regulations. Failure to install a ground fault circuit interrupter may cause electric shocks and fire.
- Make sure all wiring is secure. Use the specified wires and ensure that terminal connections or wires are protected from water and other adverse external forces. Incomplete connection or affixing may cause a fire.
- When wiring the power supply, form the wires so that the front panel can be securely fastened. If the front panel is not in place there could be overheating of the terminals, electric shocks or fire.
- After completing the installation work, check to make sure that there is no refrigerant leakage.
- Never directly touch any leaking refrigerant as it could cause severe frostbite.

- Do not touch the refrigerant pipes during and immediately after operation as the refrigerant pipes may be hot or cold, depending on the condition of the refrigerant flowing through the refrigerant piping, compressor and other refrigerant cycle parts. Burns or frostbite are possible if you touch the refrigerant pipes. To avoid injury, give the pipes time to return to normal temperature or, if you must touch them, be sure to wear protective gloves.
- Do not touch the internal parts during and immediately after operation. Touching the internal parts can cause burns. To avoid injury, give the internal parts time to return to normal temperature or, if you must touch them, be sure to wear protective gloves.

CAUTION

- Ground the unit.
- Grounding resistance should be according to local laws and regulations.
- Do not connect the ground wire to gas or water pipes, lightning conductors or telephone ground wires.
- Incomplete grounding may cause electric shocks.
 - Gas pipes: Fire or an explosion might occur if the gas leaks.
 - Water pipes: Hard vinyl tubes are not effective grounds.
 - Lightning conductors or telephone ground wires: Electrical threshold may rise abnormally if struck by a lightning bolt.
- Install the power wire at least 3 feet (1 meter) away from televisions or radios to prevent interference or noise. (Depending on the radio waves, a distance of 3 feet (1 meter) may not be sufficient to eliminate the noise.)
- Do not wash the unit. This may cause electric shocks or fire. The appliance must be installed in accordance with national wiring regulations. If the supply cord is damaged, it must be replaced by the manufacturer, its service agent or similarly qualified persons in order to avoid a hazard.
- Do not install the unit in the following places:
 - Where there is mist of mineral oil, oil spray or vapors. Plastic parts may deteriorate, and cause them to come loose or water to leak.
 - Where corrosive gases (such as sulphurous acid gas) are produced. Where corrosion of copper pipes or soldered parts may **cause refrigerant to leak**.
 - Where there is machinery which emits electromagnetic waves. Electromagnetic waves can disturb the control system and **cause equipment malfunction**.
 - Where flammable gases may leak, where carbon fiber or ignitable dust is suspended in the air or where volatile flammables such as paint thinner or gasoline are handled. These types of gases might **cause a fire**.
 - Where the air contains high levels of salt such as near the ocean.
 - Where voltage fluctuates a lot, such as in factories.
 - In vehicles or vessels.
 - Where acidic or alkaline vapors are present.
- This appliance can be used by children 8 years old and above and persons with reduced physical, sensory or mental capabilities or lack of experience and knowledge if they are supervised or given instruction on using the unit in a safe manner and understand the hazards involved. Children should not play with the unit. Cleaning and user maintenance should not be **done by children without supervision**.
- Children should be supervised to ensure that they do not play with the appliance.
- **DISPOSAL:** Do not dispose this product as unsorted municipal waste. Collection of such waste separately for special treatment is necessary. Do not dispose of electrical appliances as municipal waste, use separate collection facilities. Contact your local government for information regarding the collection systems available. If electrical appliances are disposed of in landfills or dumps, hazardous substance can leak into the groundwater and get into the food chain, damaging your health and well-being.
- The wiring must be performed by professional technicians in accordance with national wiring regulation and this circuit diagram. An all-pole disconnection device which has at least 3mm separation distance in all pole and a residual current device (RCD) with the rating not exceeding 30mA shall be incorporated in the fixed wiring according to the national rule.
- Confirm the safety of the installation area (walls, floors, etc.) without hidden dangers such as water, electricity, and gas. Before wiring/ pipes.
- Before installation check whether the user's power supply meets the electrical installation requirements of unit (including reliable grounding, leakage, and wire diameter electrical load, etc.). If the electrical installation requirements of the product are not met, the installation of the product is prohibited until the product is rectified.
- When installing multiple air conditioners in a centralized manner, please confirm the load balance of the three-phase power supply, and multiple units are prevented from being assembled into the same phase of the three-phase power supply.
- Product installation should be fixed firmly. Take reinforcement measures, when necessary.

NOTE

About Fluorinated Gasses

- This air-conditioning unit contains fluorinated gasses. For specific information on the type of gas and the amount, please refer to the relevant label on the unit itself. Compliance with national gas regulations shall be observed.
- Installation, service, maintenance and repair of this unit must be performed by a certified technician.
- Product uninstallation and recycling must be performed by a certified technician.
- If the system has a leak-detection system installed, it must be checked for leaks at least every 12 months. When the unit is checked for leaks, proper record-keeping of all checks is strongly recommended.

2 GENERAL INTRODUCTION

These units are used for both heating and cooling applications and domestic hot water tanks. They can be combined with fan coil units, floor heating applications, low temperature high efficiency radiators, domestic hot water tanks and solar kits, which are all field supplied.

A wired controller is supplied with the unit .

If you add an optional backup heater unit, the backup heater can increase the heating capacity during cold outdoor temperature. The backup heater also serves as a backup in case of malfunctioning and for frozen protection of the outside water piping during winter time.

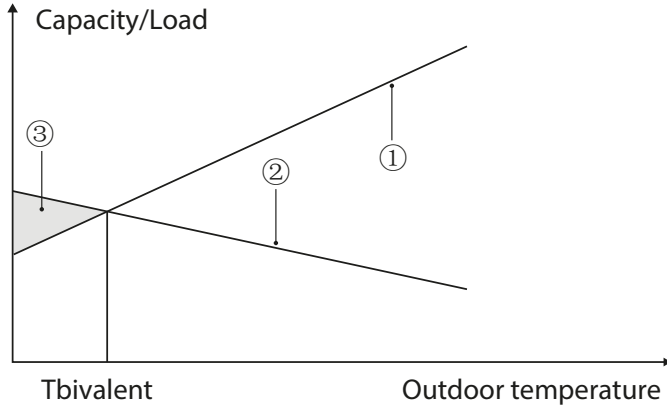

- 1 Heat pump capacity.
- 2 Required heating capacity (site dependent).
- 3 Additional heating capacity provided by backup heater.

Domestic hot water tank (field supply)

A domestic hot water tank (with or without booster heater) can be connected to the unit.

The requirement of the tank is different for different unit and material of heat exchanger.

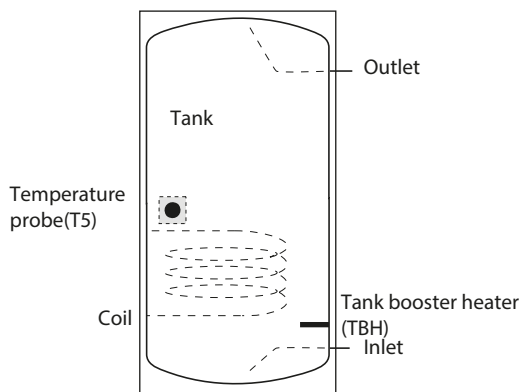

The booster heater should be installed below the temperature probe (T5).

The heat exchanger (coil) should be installed below the temperature probe.

The pipe length between the outdoor unit and tank should be less than 5 meters.

Model		4-6kW	8-10kW	12-16kW
Volume of tank/L	Recommended	100~250	150~300	200~500
Heat exchange area/m ² (Stainless steel coil)	Minimum	1,4	1,4	1,6
Heat exchange area/m ² (Enamel coil)	Minimum	2,0	2,0	2,5

Room thermostat (field supplied)

Room thermostat can be connected to the unit(room thermostat should be kept away from heating source when selecting the installation place).

Solar kit for domestic hot water tank(field supplied)

An optional solar kit can be connected to the unit.

Operation range

Outlet water (Heating mode)	+12 ~ +65°C	
Outlet water (Cooling mode)	+5 ~ +25°C	
Domestic hot water	+12 ~ +60°C	
Ambient temperature	-25 ~ +43°C	
Water pressure	0,1~0,3MPa(g)	
Water flow	4kW	0,40~0,90m ³ /h
	6kW	0,40~1,25m ³ /h
	8kW	0,40~1,65m ³ /h
	10kW	0,40~2,10m ³ /h
	12kW	0,70~2,50m ³ /h
	14kW	0,70~2,75m ³ /h
16kW	0,70~3,00m ³ /h	

The unit have a freeze prevention function that uses the heat pump or backup heater (optional) to keep the water system safe from freezing in all conditions. Since a power failure may happen when the unit is unattended, It's suggested to use anti-freezing flow switch in the water system. (Refer to 9.4 "Water piping").

In cooling mode, the water flowing temperature (TW_out) range in different outdoor temperature (T4) is listed below:

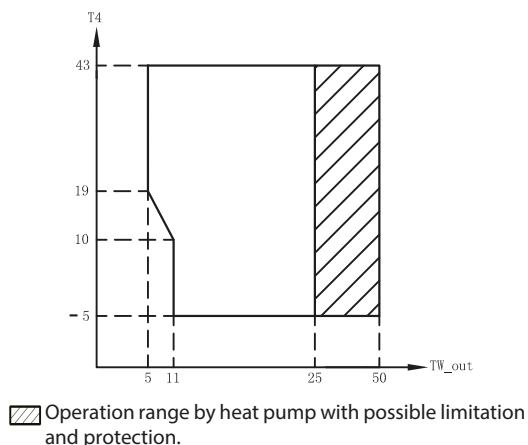

In heating mode, the water flowing temperature (TW_out) range in different outdoor temperature (T4) is listed below:

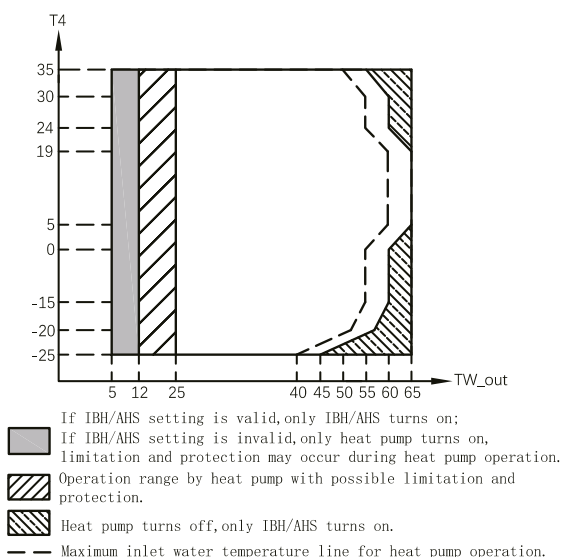

In DHW mode, the water flowing temperature (TW_out) range in different outdoor temperature (T4) is listed below:

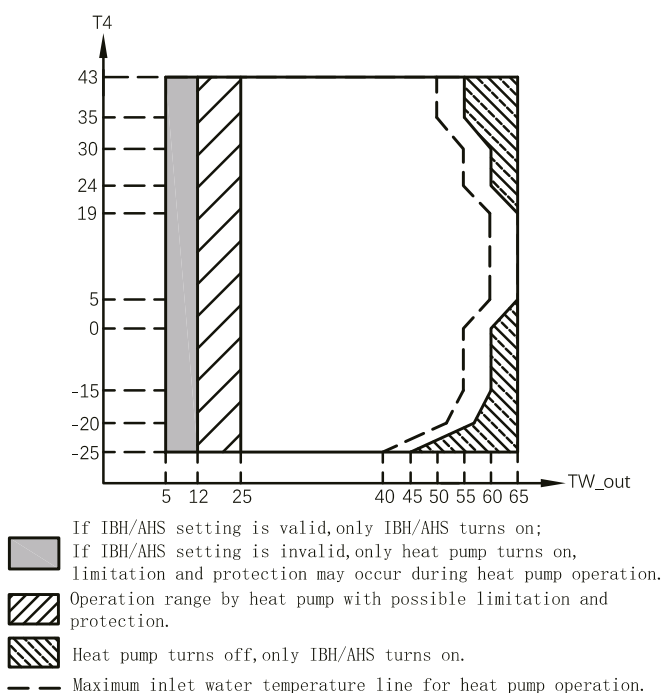

3 ACCESSORIES

Accessories supplied with the unit

Installation Fittings		
Name	Shape	Quantity
Installation and owner's manual(this book)		1
Remote control manual		1
Y-shape filter		1
Wired controller		1
Thermistor for domestic hot water tank or zone2 water flow or balance tank		1
Drain hose		1
Energy label		1
Tighten belt for customer wiring use		2
		3
Network adapting wire		1

Accessories available from supplier

Thermistor for balance tank(Tbt1)		1
Extension wire for Tbt1		1
Thermistor for Zone 2 flow temp.(TW2)		1
Extension wire for TW2		1
Thermistor for solar temp.(Tsolar)		1
Extension wire for Tsolar		1

Thermistor and extension wire for Tbt1, TW2, Tsolar can be shared, if these functions are needed at the same time, and 10m in length of the sensor cable please order these thermistors and extension wire additionally.

4 BEFORE INSTALLATION

Before installation

Be sure to confirm the model name and the serial number of the unit.

Handling

Due to relatively large dimensions and heavy weight, the unit should only be handled using lifting tools with slings. The slings can be fitted into foreseen sleeves at the base frame that are made specifically for this purpose.

⚠ CAUTION

- To avoid injury, do not touch the air inlet or aluminum fins of the unit.
- Do not use the grips in the fan grills to avoid damage.
- The unit is top heavy! Prevent the unit from falling due to improper inclination during handling.

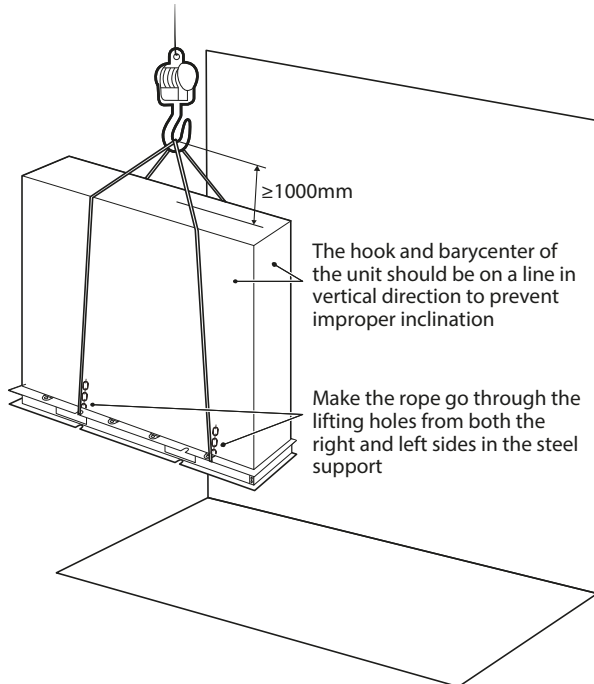

Model	A	B	C
1 phase 4/6kW	370	540	190
1 phase 8/10kW	410	580	280
1 phase 12/14/16kW	370	605	245
3 phase 12/14/16kW	280	605	245

- The position of the barycenter for different units can be seen in the picture below

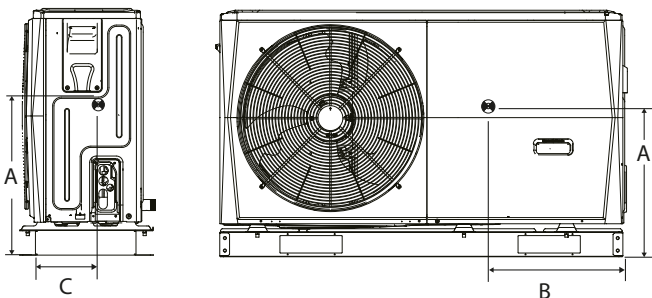

4/6 kW (unit:mm)

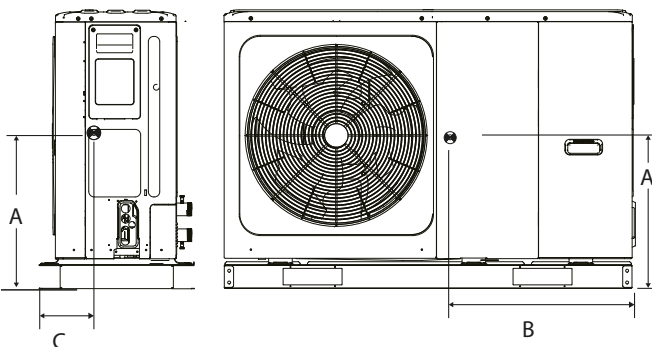

8/10/12/14/16 kW (unit:mm)

5 IMPORTANT INFORMATION FOR THE REFRIGERANT

This product has the fluorinated gas, which is forbidden to release to air. Refrigerant type: R32; Volume of GWP: 675. GWP=Global Warming Potential

Factory charged refrigerant volume in the unit		
Model	Refrigerant/kg	Tonnes CO ₂ equivalent
4kW	1.40	0.95
6kW	1.40	0.95
8kW	1.40	0.95
10kW	1.40	0.95
12kW	1.75	1.18
14kW	1.75	1.18
16kW	1.75	1.18

⚠ CAUTION

- **Frequency of Refrigerant Leakage Checks**
 - For unit that contains fluorinated greenhouse gases in quantities of 5 tonnes of CO₂ equivalent or more, but of less than 50 tonnes of CO₂ equivalent, at least every 12 months, or where a leakage detection system is installed, at least every 24 months.
 - For unit that contains fluorinated greenhouse gases in quantities of 50 tonnes of CO₂ equivalent or more, but of less than 500 tonnes of CO₂ equivalent at least every six months, or where a leakage detection system is installed, at least every 12 months.
 - For unit that contains fluorinated greenhouse gases in quantities of 500 tonnes of CO₂ equivalent or more, at least every three months, or where a leakage detection system is installed, at least every six months.
 - This air-conditioning unit is a hermetically sealed equipment that contains fluorinated greenhouse gases.
 - Only certificated person is allowed to do installation, operation and maintenance.

6 INSTALLATION SITE

⚠ WARNING

There is flammable refrigerant in the unit and it should be installed in a well-ventilated site.

The unit is suitable for outdoor installations.

Be sure to adopt adequate measures to prevent the unit from being used as a shelter by small animals.

- Small animals making contact with electrical parts can cause malfunction, smoke or fire. Please instruct the customer to keep the area around the unit clean.
- Select an installation site where the following conditions are satisfied and one that meets with your customer's approval.
 - Places that are well-ventilated.
 - Places where the unit does not disturb neighbors.
 - Safe places which can bear the unit's weight and vibration and where the unit can be installed at an even level.
 - Places where there is no possibility of flammable gas or product leak.
 - The equipment is not intended for use in a potentially explosive atmosphere.
 - Places where servicing space can be well ensured.
 - Places where the units' piping and wiring lengths come within the allowable ranges.
 - Places where water leaking from the unit cannot cause damage to the location (e.g. in case of a blocked drain pipe).
 - Places where rain can be avoided as much as possible.

- Do not install the unit in places often used as a work space. In case of construction work (e.g. grinding etc.) where a lot of dust is created, the unit must be covered.
- Do not place any object or equipment on top of the unit (top plate).
- Do not climb, sit or stand on top of the unit.
- Be sure that sufficient precautions are taken in case of refrigerant leakage according to relevant local laws and regulations.
- Don't install the unit near the sea or where there is corrosion gas.
- When installing the unit in a place exposed to strong wind, pay special attention to the following.
- Strong winds of 5 m/sec or more blowing against the unit's air outlet causes a short circuit (suction of discharge air), and this may have the following consequences:
 - Deterioration of the operational capacity.
 - Frequent frost acceleration in heating operation.
 - Disruption of operation due to rise of high pressure.
 - When a strong wind blows continuously on the front of the unit, the fan can start rotating very fast until it breaks. In normal condition, refer to the figures below for installation of the unit:

- Prepare a water drainage channel around the foundation, to drain waste water from around the unit.
- If water does not easily drain from the unit, mount the unit on a foundation of concrete blocks, etc. (the height of the foundation should be about 100 mm).
- If you install the unit on a frame, please install a waterproof plate (about 100 mm) on the underside of the unit to prevent water from coming in from the low side.
- When installing the unit in a place frequently exposed to snow, pay special attention to elevate the foundation as high as possible.

If you install the unit on a building frame, please install a waterproof tray (field supply) (about 100mm, on the underside of the unit) in order to avoid drain water dripping. (See the picture in the right).



6.1 Selecting a location in cold climates

Refer to "Handling" in section "4 Before installation"

NOTE

When operating the unit in cold climates, be sure to follow the instructions described below.

- To prevent exposure to wind, install the unit with its suction side facing the wall.
- Never install the unit at a site where the suction side may be exposed directly to wind.
- To prevent exposure to wind, install a baffle plate on the air discharge side of the unit.
- In heavy snowfall areas, it is very important to select an installation site where the snow will not affect the unit. If lateral snowfall is possible, make sure that the heat exchanger coil is not affected by the snow (if necessary construct a lateral canopy).

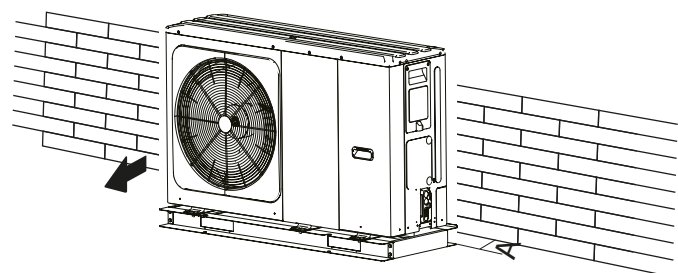

Unit	A(mm)
4~6kW	≥300
8~16kW	≥300

In case of strong wind and the wind direction can be foreseen, refer to the figures below for installation of the unit (any one is OK): Turn the air outlet side toward the building's wall, fence or screen.

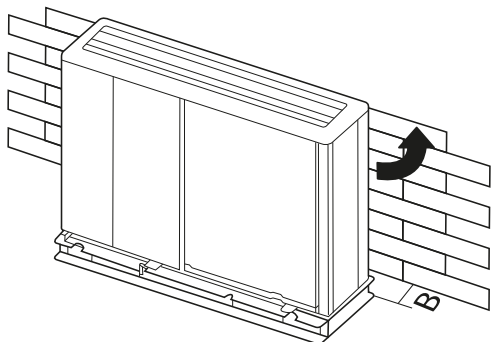

Unit	B(mm)
4~6kW	≥1000
8~16kW	≥1500

Make sure there is enough room to do the installation. Set the outlet side at a right angle to the direction of the wind.

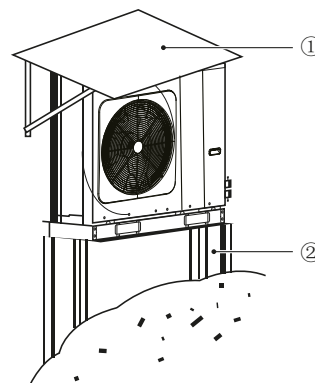
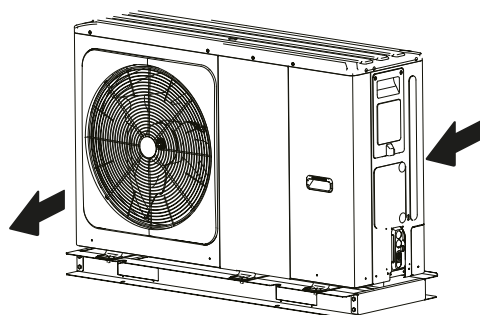

1 Construct a large canopy.

2 Construct a pedestal.

Install the unit high enough off the ground to prevent it from being buried in snow.

6.2 Selecting a location in hot climates

As the outdoor temperature is measured via the outdoor unit air thermostat, make sure to install the outdoor unit in the shade or a canopy should be constructed to avoid direct sunlight, so that it is not influenced by the sun's heat, otherwise protection may be possible to the unit.

7 INSTALLATION PRECAUTIONS

7.1 Dimensions

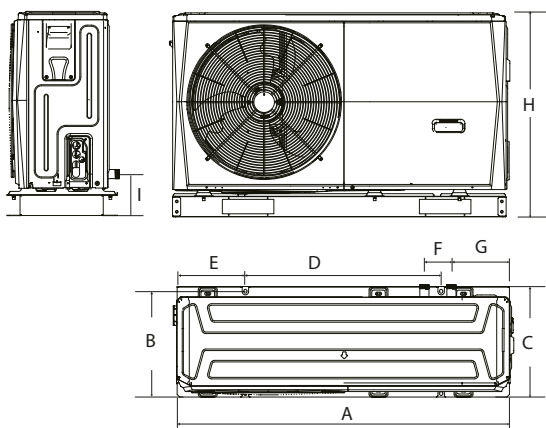

4/6 kW (unit: mm)

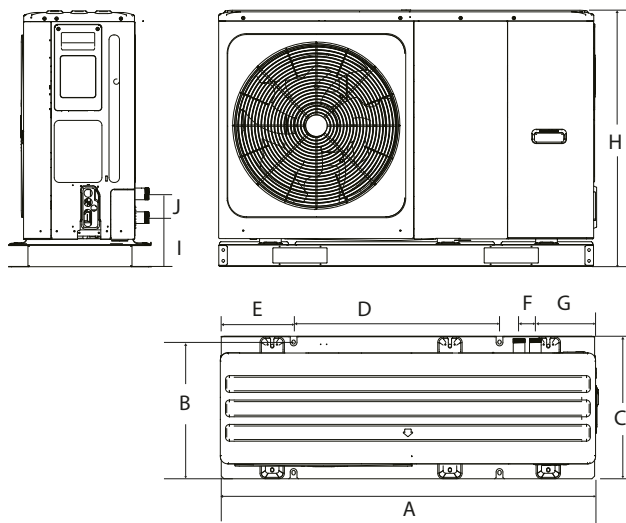

8/10/12/14/16 kW (unit: mm)

Model	A	B	C	D	E	F	G	H	I	J
4/6kW	1295	397	429	760	265	105	225	792	161	/
8/10/12/14/16kW	1385	482	526	760	270	60	221	945	182	81

Model	4	6	8	10	12	14	16	
Water connection diameter (Ø)	R1"	R1"	R5/4"					

7.2 Installation requirements

- Check the strength and level of the installation ground so that the unit may not cause any vibrations or noise during its operation.
- In accordance with the foundation drawing in the figure, fix the unit securely by means of foundation bolts. (Prepare four sets each of Ø10 Expansion bolts, nuts and washers which are readily available in the market.)
- Screw in the foundation bolts until their length is 20 mm from the foundation surface.

(unit: mm)

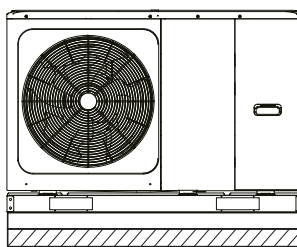
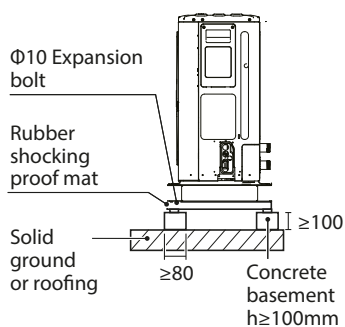

7.3 Drain hole position

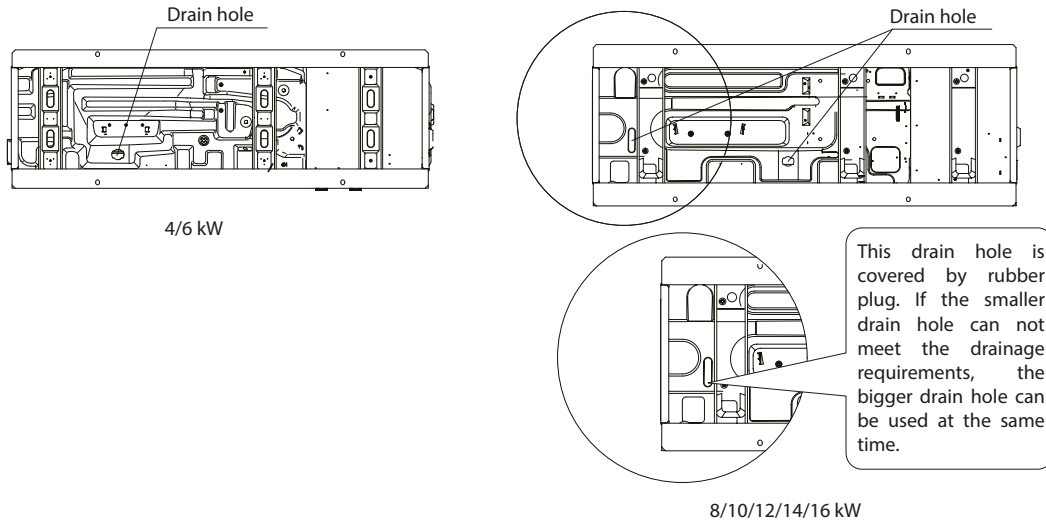

NOTE

It's necessary to install an electrical heating belt if water can't drain out in cold weather, even the bigger drain hole has opened.

7.4 Servicing space requirements

7.4.1 In case of stacked installation

1) In case obstacles exist in front of the outlet side.

2) In case obstacles exist in front of the air inlet.

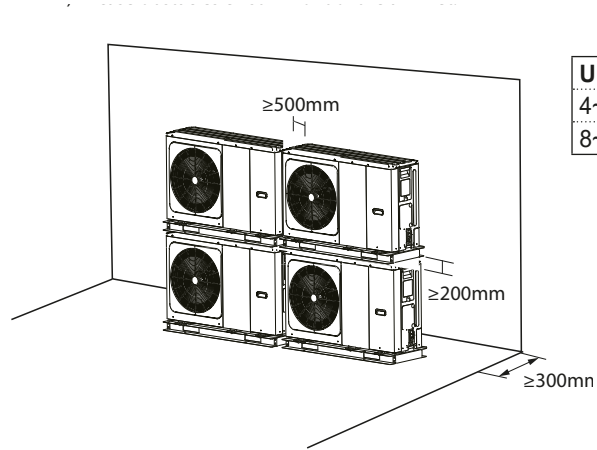
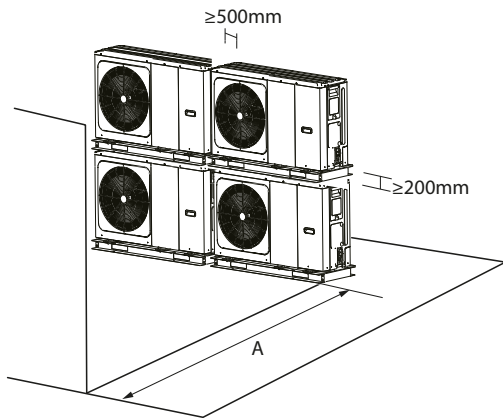

Unit	A(mm)
4~6kW	≥1000
8~16kW	≥1500

7.4.2 In case of multiple-row installation (for roof top use, etc)

In case of installing multiple units in lateral connecting per row

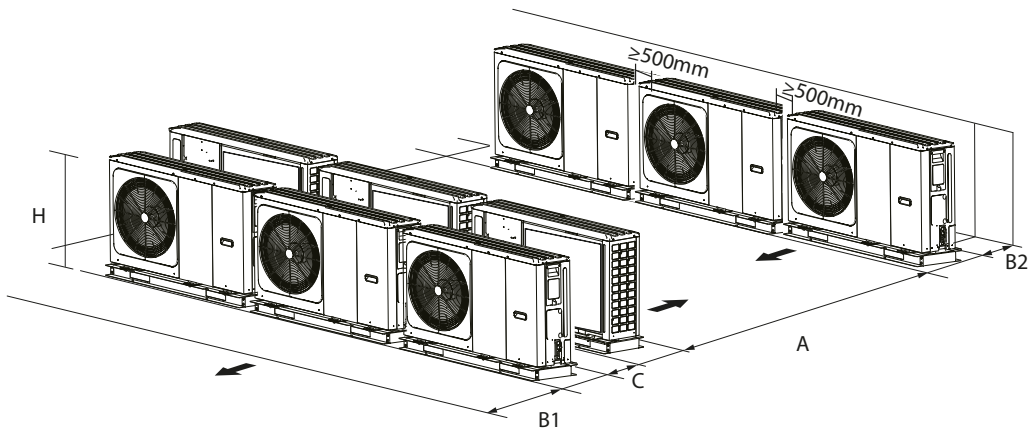

Unit	A(mm)	B1(mm)	B2(mm)	C(mm)
4~6kW	≥2500	≥1000	≥300	≥600
8~16kW	≥3000	≥1500	≥300	≥600

8 TYPICAL APPLICATIONS

The application examples given below are for illustration only.

8.1 Application 1

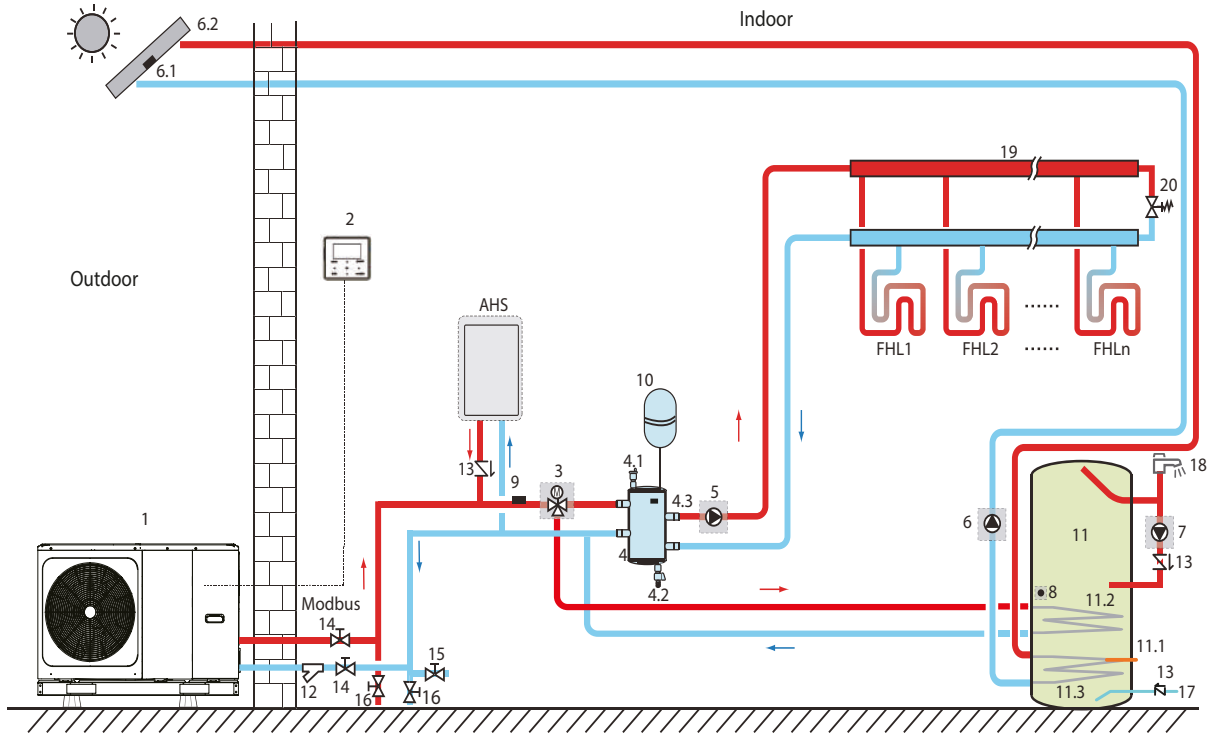

Code	Assembly unit	Main unit	User interface	Code	Assembly unit
1	Main unit			11	Domestic hot water tank (Field supply)
2	User interface			11.1	TBH: Domestic hot water tank booster heater (Field supply)
3	SV1: 3-way valve (Field supply)			11.2	Coil 1 , heat exchanger for heat pump
4	Balance tank (Field supply)			11.3	Coil 2 , heat exchanger for Solar energy
4.1	Automatic air purge valve			12	Filter (Accessory)
4.2	Drainage valve			13	Check valve (Field supply)
4.3	Tbt1: Balance tank upper temperature sensor (Optional)			14	Shut -off valve (Field supply)
5	PUMP O: Outside circulation pump (Field supply)			15	Filling valve (Field supply)
6	PUMP S: Solar pump (Field supply)			16	Drainage valve (Field supply)
6.1	Tsolar: Solar temperature sensor (Optional)			17	Tap water inlet pipe (Field supply)
6.2	Solar panel (Field supply)			18	Hot water tap (Field supply)
7	PUMP D: DHW pipe pump (Field supply)			19	Collector/distributor (Field supply)
8	T5: Domestic water tank temperature sensor (Accessory)			20	Bypass valve (Field supply)
9	T1:Total water flow temperature sensor (Optional)			FHL 1...n	Floor heating loop (Field supply)
10	Expansion vessel (Field supply)			AHS	Auxiliary heat source (Field supply)

Space heating

The ON/OFF signal and operation mode and temperature setting are set on the user interface. PUMP O keeps running as long as the unit is ON for space heating, SV1 keeps OFF.

Domestic water heating

The ON/OFF signal and target tank water temperature (T5S) are set on the user interface. PUMP O stops running as long as the unit is ON for domestic water heating, SV1 keeps ON.

AHS (auxiliary heat source) control

The AHS function is set on the hydraulic main board (See 10.1 "DIP switch settings overview")

- 1) When the AHS is set to be valid only for heating mode, AHS can be turned on in the following ways:
 - a. Turn on the AHS via BACKHEATER function on the user interface;
 - b. AHS will be turned on automatically if initial water temperature is too low or if the outdoor ambient temperature is too low to reach target water temperature (see graph "Operation range" in heating mode - page 80). PUMP O keeps running as long as the AHS is ON, SV1 keeps OFF.
- 2) When the AHS is set to be valid for heating mode and DHW mode:
 - a. in heating mode, AHS control is same as part 1);
 - b. in DHW mode, AHS will be turned on automatically when the initial domestic water temperature T5 is too low or if the outdoor ambient temperature is too low to reach target water temperature (see graph "Operation range" in DHW mode - page 80). PUMP O stops running, SV1 keeps ON.
- 3) When the AHS is set to be valid, it is possible to assign M1M2 switch to control AHS. In this way, if M1M2 dry contact closes, AHS will be turned on; this function is invalid in DHW mode (cfr. 10.5.15 "input define").

TBH (tank booster heater) control

The TBH function is set on the user interface. (See 10.1 "DIP switch settings overview")

- 1) When the TBH is set to be valid, TBH can be turned on in the following ways:
 - a. Turn on the TBH via TANKHEATER function on the user interface;
 - b. TBH will be turned on automatically in DHW mode when the initial domestic water temperature T5 is too low or if the outdoor ambient temperature is too low to reach target water temperature (see graph "Operation range" in DHW mode - page 80).
- 2) When the TBH is set to be valid, it is possible to assign M1M2 switch to control TBH. In this way, if M1M2 dry contact closes, TBH will be turned on in DHW mode (cfr. 10.5.15 "input define")

Solar energy control

Hydraulic module recognizes solar energy signal by judging Tsolar or receiving SL1SL2 signal from user interface (See 10.5.15 INPUT DEFINE). The recognition method can be set via SOLAR INPUT on the user interface. Please refer to 9.7.6 "Connection for other components" - 1) "For solar energy input signal" for wiring.

- 1) When Tsolar is set to be valid, PUMP S starts running when Tsolar is high enough; PUMP S stops running when Tsolar is low.
- 2) When SL1SL2 control is set to be valid, PUMP S starts running after receiving solar kit signal from user interface. Without solar kit signal PUMP S stops running.

CAUTION

The highest outlet water temperature may reach 70°C, please beware of burn.

NOTE

Make sure to fit the (SV1) 3-way valve correctly. For more details, please refer to 9.7.6 "Connection for other components."

At extremely low ambient temperature, the domestic hot water is exclusively heated by TBH, which assures that heat pump can be used for space heating with full capacity.

Details on domestic hot water tank configuration for low outdoor temperatures (T4DHWMIN) can be found in 10.5.1 "DHW MODE SETTING".

8.2 Application 2

ROOM THERMOSTAT Control for Space heating or cooling need to be set on the user interface. It can be set in three ways: MODE SET/ONE ZONE/DOUBLE ZONE. The monobloc can be connected to a high voltage room thermostat and a low voltage room thermostat. A thermostat transfer board can also be connected. Another six thermostats can be connected to the thermostat transfer board. Please refer to 9.7.6/5) "For room thermostat" for wiring. (see 10.5.6 "ROOM THERMOSTAT" for setting).

8.2.1 One zone control

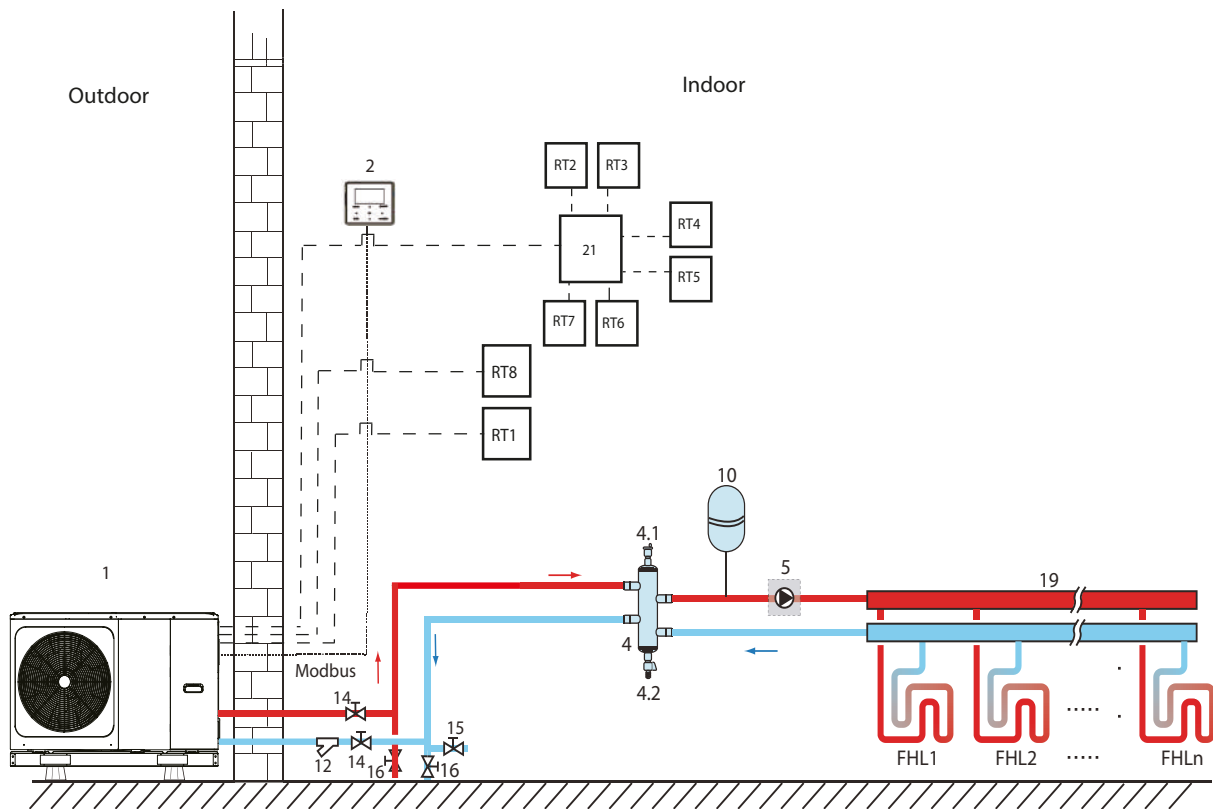

Code	Assembly unit	Code	Assembly unit
1	Main unit	14	Shut -off valve (Field supply)
2	User interface	15	Filling valve (Field supply)
4	Balance tank (Field supply)	16	Drainage valve (Field supply)
4.1	Automatic air purge valve	19	Collector/distributor (Field supply)
4.2	Drainage valve	21	Thermostat transfer board (Optional)
5	PUMP O: Outside circulation pump (Field supply)	RT 1...7	Low voltage room thermostat (Field supply)
10	Expansion vessel (Field supply)	RT8	High voltage room thermostat (Field supply)
12	Filter (Accessory)	FHL 1...n	Floor heating loop (Field supply)

Space heating

One zone control: the unit ON/OFF is controlled by the room thermostat, cooling or heating mode and outlet water temperature are set on the user interface. System is ON when any "HL" of all the thermostats closes (heating request from one of the room thermostats - see paragraph 9.7.6). When all "HL" open, system turns OFF.

The circulation pumps operation

When the system is ON, which means any "HL" of all the thermostats closes, PUMP O starts running; When the system is OFF, which means all "HL" close, PUMP O stops running.

8.2.2 Mode set control

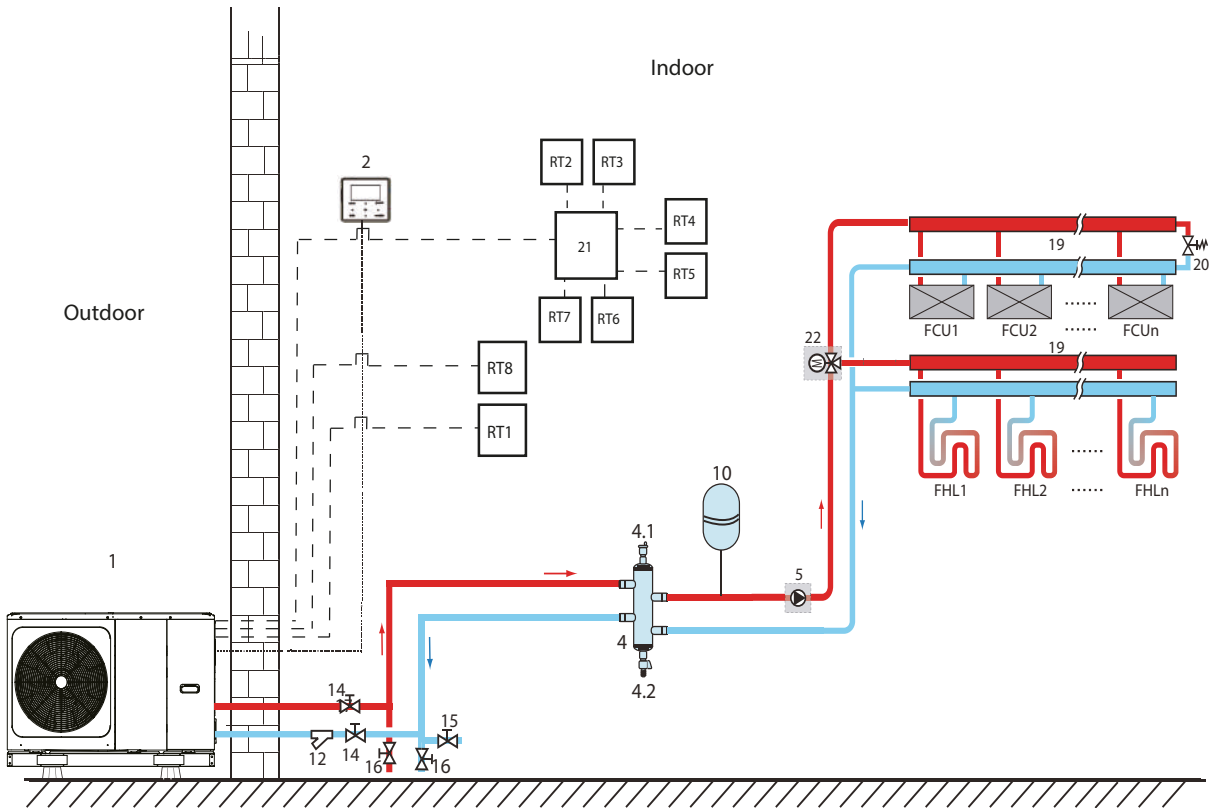

Code	Assembly unit	Code	Assembly unit
1	Main unit	19	Collector/distributor
2	User interface	20	Bypass valve (Field supply)
4	Balance tank (Field supply)	21	Thermostat transfer board (Field supply)
4.1	Automatic air purge valve	22	SV2: 3 -way valve (Field supply)
4.2	Drainage valve	RT 1..... 7	Low voltage room thermostat
5	PUMP O: Outside circulation pump (Field supply)	RT8	High voltage room thermostat
10	Expansion vessel (Field supply)	FHL	Floor heating loop (Field supply)
12	Filter (Accessory)	1...n	
14	Shut-off valve (Field supply)	FCU	Fan coil unit (Field supply)
15	Shut-off valve	1...n	
16	Drainage valve (Field supply)		

Space heating

Cooling or heating mode is set via the room thermostat, water temperature is set on the user interface.

- 1) When any "CL" of all the thermostats close (cooling request from one of the room thermostats - see paragraph 9.7.6), system will be set at cooling mode.
- 2) When any "HL" of all the thermostats close and all "CL" open, system will be set at heating mode.

The circulation pumps operation

- 1) When the system is in cooling mode, which means any "CL" of all the thermostats closes, SV2 keeps OFF, PUMP O starts running.
- 2) When the system is in heating mode, which means one or more "HL" close and all "CL" open, SV2 keeps ON, PUMP O starts running.

8.2.3 Double zone control

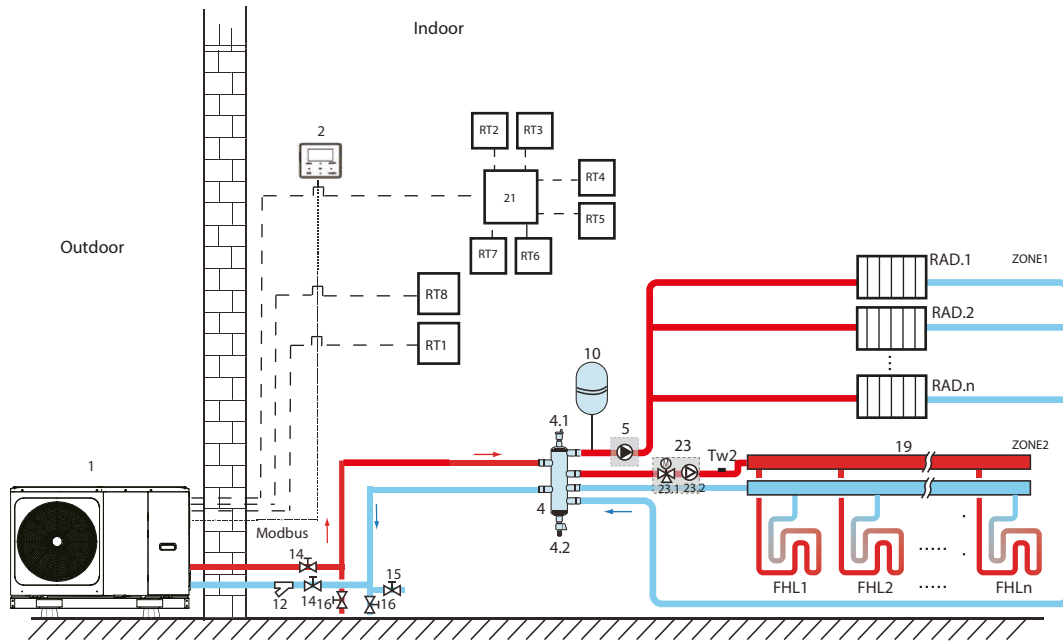

Code	Assembly unit	Code	Assembly unit
1	Main unit	19	Collector/distributor (Field supply)
2	User interface	21	Thermostat transfer board (optional)
4	Balance tank (Field supply)	23	Mixing station (Field supply)
4.1	Automatic air purge valve	23.1	SV3: Mixing valve (Field supply)
4.2	Drainage valve	23.2	PUMP C: zone 2 circulation pump (Field supply)
5	PUMP O: zone 1 circulation pump (Field supply)	RT 1...7	Low voltage room thermostat (Field supply)
10	Expansion vessel (Field supply)	RT8	High voltage room thermostat (Field supply)
12	Filter (Accessory)	TW2	Zone 2 water flow temperature sensor (Optional)
14	Shut-off valve (Field supply)	FHL 1...n	Floor heating loop (Field supply)
15	Filling valve (Field supply)	RAD. 1...n	Radiator (Field supply)
16	Drainage valve (Field supply)		

Space heating

Zone1 can operate in cooling mode or heating mode, while zone 2 can only operate in heating mode while installation for all thermostats in zone1, only "HL" terminals need to be connectet.

For all thermostats in zone 2,only "CL" terminals need to be connected.

- 1) The ON/OFF of zone1 is controlled by the room thermostats in zone1.
When any "HL" of all thermostats in zone1 closes, zone1 turns ON.
When all "HL" turn OFF, zone1 turns OFF;
Target temperature and operation mode are set on the user interface.
- 2) In heating mode, the ON/OFF of zone2 is controlled by the room thermostas in zone2.
When any "CL" of all thermostats in zone2 closes, zone2 turns ON.
When all "CL" open, zone2 turns OFF.
Target temperature is set on the user interface.
Zone2 can only operate in heating mode.
When cooling mode is set on the user interface, zone2 keeps in OFF status.

The circulation pump operation

When zone1 is ON, PUMP O starts running.

when zone1 is OFF, PUMP O stops running.

when zone2 is ON, SV3 switches between ON and OFF according to the set TW2, PUMP C keeps ON.

when zone2 is OFF, SV3 is OFF, PUMP C stops running.

The floor heating loops require a lower water temperature in heating mode compared to radiators or fan coil unit. To achive these two setpoints, a mixing station is used to adapt the water temperature according to requirement of the floor heating loops. The radiators are directly connected to the unit water circuit and the floor heatin loops are after the mixing station. The mixing station is controlled by the unit.

CAUTION

- 1) Make sure to connect the SV2/SV3 terminals in the wired controller correctly, please refer to 9.7.6/2 for 3-way valve SV1,SV2,SV3.
- 2) Wire the thermostat to the correct terminals and configure the ROOM THERMOSTAT in the wired controller correctly. Wiring of the room thermostat should followmethod A/B/C as described in 9.7.6 "Connection for other components/5 for room thermostats

NOTE

- 1) Zone 2 can only operate in heating mode. When cooling mode is set on user interface and zone 1 is OFF, "CL" in zone 2 closes, system still keeps "OFF". While installation, the wiring of thermostats for zone 1 and zone 2 must be correct.
- 2) Drainage valve must be installed at the lowest position of the piping system.

8.3 Cascade system

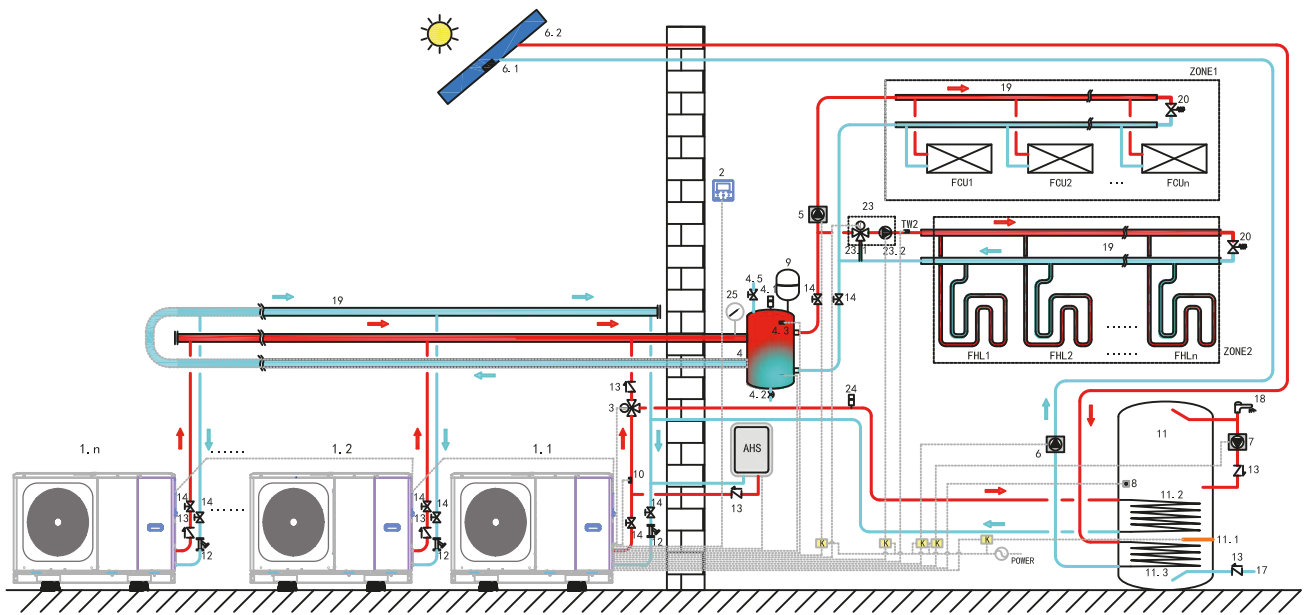

Code	Assembly unit	Code	Assembly unit	Code	Assembly unit
1.1	Master unit	8	T5:Domestic water tank temperature sensor (Accessory)	23	Mixing station (Field supply)
1.2... n	Slave unit	9	Expansion vessel (Field supply)	23.1	SV3:Mixing valve (Field supply)
2	User interface	10	T1:Total water flow temperature sensor (Optional)	23.2	PUMP C:Zone2 circulation pump (Field supply)
3	SV1 3-way valve (Field supply)	11	Domestic hot water tank (Field supply)	24	Automatic air purge valve (field supply)
4	Balance tank (field supply)	11.1	TBH : Domestic hot water tank booster heater	25	Water manometer (field supply)
4.1	Automatic air purge valve	11.2	Coin 1,heat exchanger far heat pump	TW2	Zone2 water flow temperature sensor (Optional)
4.2	Drainage valve	11.3	Coin 2,heat exchanger far solar energy	FCU1... n	Fan coil unit (field supply)
4.3	Tbt1 Balance tank upper temperature sensor (optional)	12	Filter (accessory)	FHL1... n	Floor heating loop (field supply)
4.5	Filling valve	13	Check valve (field supply)	K	Contactor (field supply)
5	PUMP O: Outside circulation pump (Field supply)	14	Shut-off valve (field supply)	ZONE1	The zone operates cooling or heating mode
6	PUMP S: Solar pump (Field supply)	17	Tap water inlet pipe (field supply)	ZONE2	The zone operates in heating mode only
6.1	Tsolar:Solar temperature sensor (Optional)	18	Hot water tap (field supply)	AHS	Auxiliary heat source (field supply)
6.2	Solar panel (Field supply)	19	Collector/distributor (field supply)		
7	PUMP D: DHW pipe pump (Field supply)	20	Bypass valve (field supply)		

Domestic water heating

Only master unit (1.1) can operate in DHW mode. T5S is set on the user interface (2). In DHW mode, SV1(3) keeps ON. When master unit operated in DHW mode, slave units can operate in space cooling/heating mode.

Slave heating

All slave units can operate in space heating mode. The operation mode and setting temperature are set on the user interface (2). Due to changes of the outdoor temperature and the required load indoors, multiple outdoor units may operate at different times.

In cooling mode, SV3(23.1) and PUMP C (23.2) keep OFF, PUMP O (5) keeps ON;

In heating mode, when both ZONE 1 and ZONE 2 work, PUMP C (23.2) and PUMP O (5) keep ON, SV3 (23.1) switches between ON and OFF according to the set TW2;

In heating mode, when only ZONE 1 works, PUMP O (5) keep ON, SV3 (23.1) and PUMP C (23.2) keep OFF.

In heating mode, when only ZONE 2 works, PUMP O (5) keep OFF, PUMP C (23.2) keeps ON, SV3 (23.1) switches between ON and OFF according to the set TW2;

AHS (Auxiliary heat source) Control

AHS should be set via the dip switches on main board (referto 10.1); AHS is only controlled by master unit. When master unit operates in DHW mode, AHS can only be used for producing domestic hot water; when master unit operates in heating mode, AHS can only be used for heating mode.

- 1) When AHS is set valid only in heating mode, it will be turned on in following conditions:
 - a. Turn on BACKUPHEATER function on user interface;

- b. Master unit operates in heating mode. When inlet water temperature is too low, or while ambient temperature is too low, the target leaving water temperature is too high, AHS will be turned on automatically.
- 2) When AHS is set valid in heating mode and DHW mode, it will be turned on in following conditions:
When master unit operates in heating mode, conditions of turning on AHS is same as 1); When master unit operates in DHW mode, if T5 is too low or when ambient temperature is too low, target T5 temperature is too high, AHS will be turned on automatically.
- 3) When AHS is valid, and the operation of AHS is controlled by M1M2. When M1M2 closes, AHS is turned on. When master unit operates in DHW mode, AHS can't be turned on by closing M1M2.

TBH (Tank booster heater) Control

TBH should be set via the dip switches on main board (referto 10.1). TBH is only controlled by master unit. Please refer to 8.1 for specific TBH control.

Solar energy Control

Solar energy is only controlled by master unit. Please referto 8.1 for specific solar energy Control.

NOTE

- 1) Maximum 6 units can be cascaded in one system. One of them is master unit, the others are slave units. Master unit and slave units are distinguished by whether connected to wired controller while poweing on. The unit with wired controller is master unit, units without wired controller are slave units. Only master unit can operate in DHW mode. While installation, please check the cascade system diagram and determine the master unit. Before powering on, remove all wired controllers of slave units.
- 2) SV1, SV2, SV3, PUMP O, PUMP C, PUMP S, T1, T5, TW2, Tbt1, Tsolar, SL1, SL2, AHS, TBH interface are only need to be connected to corresponding terminals on main board of master unit. Please refer to 9.3.1 and 9.7.6.
- 3) The system is with auto addressing function. After initial powering on, the master unit will assign addresses for slave units. Slave units will keep the addresses. After powering on again, slave units will still use the previous addresses. The addresses of slave units aren't need set again.
- 4) If Hd error occurs, please refer to 13.4
- 5) It is suggested to use the reversed return water system in order to avoid hydraulic imbalance between each unit in a cascade system.

CAUTION

- 1) In cascade system, Tbt1 sensor must be connected to master unit and set Tbt1 valid on user interface (refer to 10.5.16) or all slave units will not work.
- 2) If outside circulation pump need to be connected in series in system when the head of internal water pump is not enough, outside circulation pump is suggested to be installed after the balance tank.
- 3) Please ensure that the maximum interval of power on time of all units doesn't exceed 2min, otherwise the time for querying and allocating addresses will be missed., which may cause the slaves to fail to communicate normally and report Hd error.
- 4) Maximum 6 units can be cascaded in one system.
- 5) The outlet pipe of each unit must be installed with a check valve.

8.4 Balance tank volume requirement

Model	Balance tank (l)
4-10 kW	≥25
12-16 kW	≥40
Cascade system	≥40*n
outdoor unit numbers	

9 OVERVIEW OF THE UNIT

9.1 Disassembling the unit

Door 1

To access to the compressor and electrical parts and hydraulic compartment

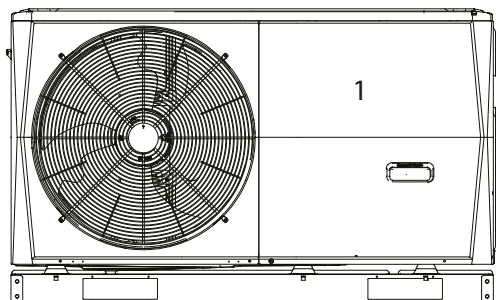

4/6kW

Door 1

To access to the compressor and electrical parts.

Door 2

To access to the hydraulic compartment and electrical parts.

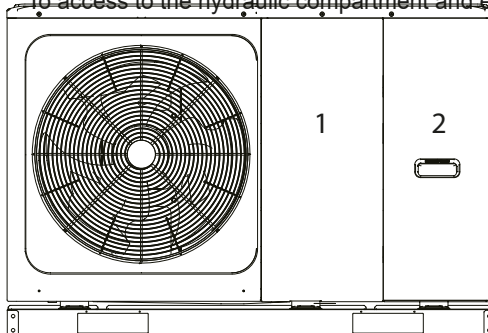

8/10/12/14/16kW

⚠ WARNING

- Switch off all power — i.e. unit power supply and backup heater and domestic hot water tank power supply (if applicable) - before removing door 1 and door 2.
- Parts inside the unit may be hot.

9.2 Main components

9.2.1 Hydraulic module

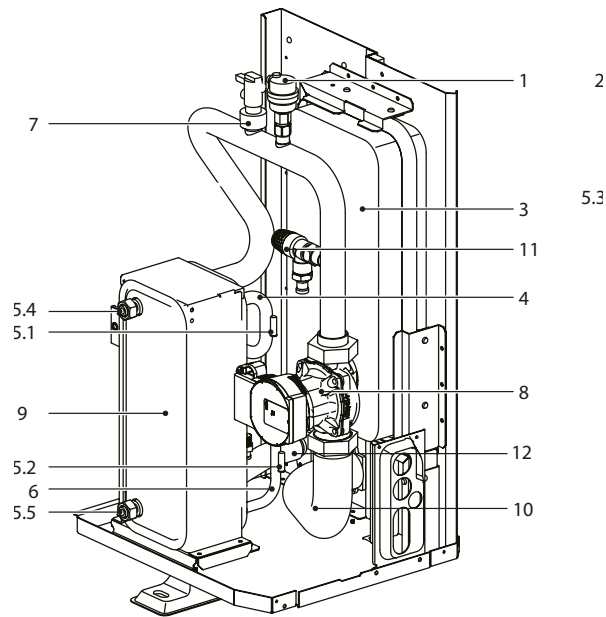

4/6 kW

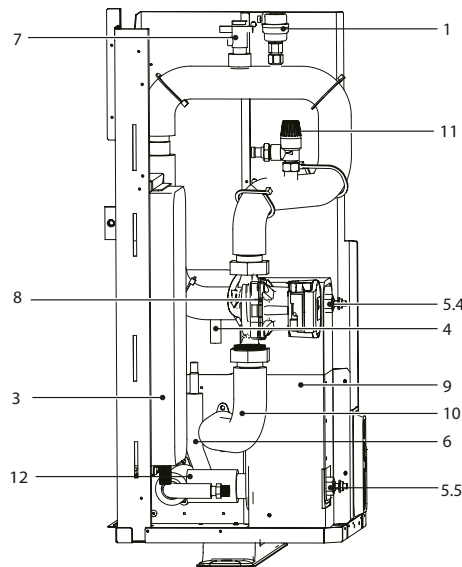

8~16 kW

Code	Assembly unit	Explanation
1	Automatic air purge valve	Remaining air in the water circuit will be automatically removed from the water circuit.
3	Expansion vessel	Balances water system pressure.
4	Refrigerant gas pipe	/
5	Temperature sensor	Four temperature sensors determine the water and refrigerant temperature at various points in the water circuit. 5.1-T2B; 5.2-T2; 5.4-TW_out; 5.5-TW_in
6	Refrigerant liquid pipe	/
7	Flow switch	Detects water flow rate to protect compressor and water pump in the event of insufficient water flow.
8	Pump	Circulates water in the water circuit.
9	Plate heat exchanger	Transfer heat from the refrigerant to the water.
10	Water outlet pipe	/
11	Pressure relief valve	Prevents excessive water pressure by opening at 3 bar and discharging water from the water circuit.
12	Water inlet pipe	/

9.3 Electronic control box

Note: The picture is for reference only, please refer to the actual product.

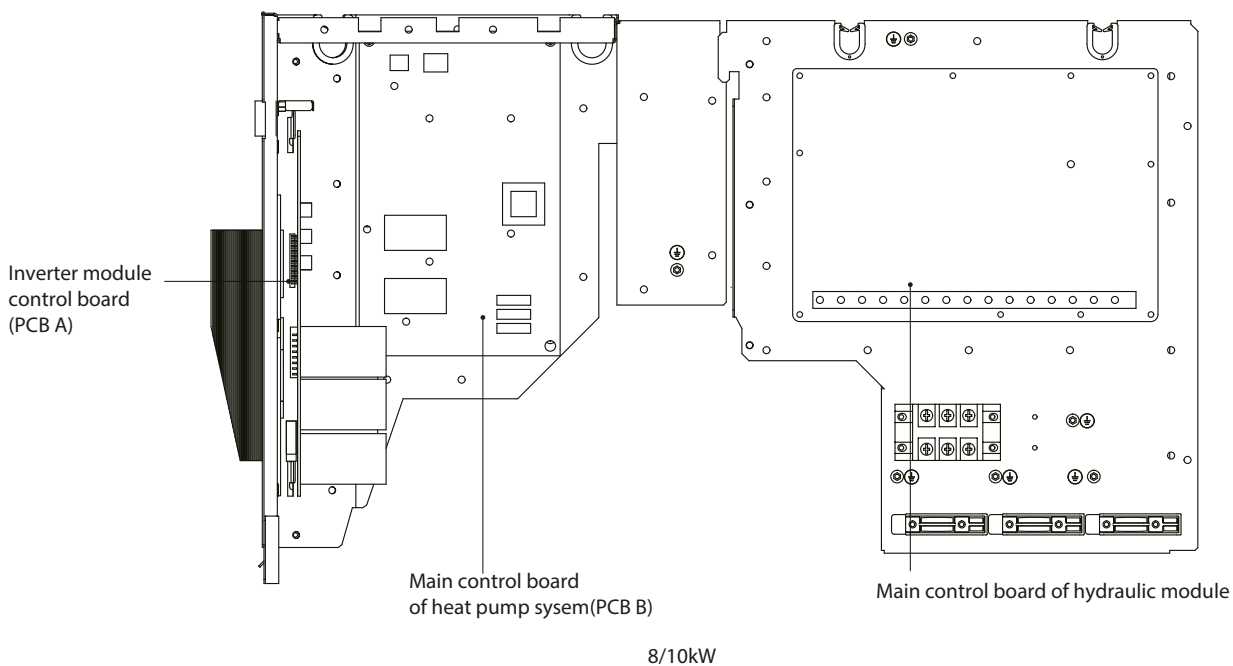
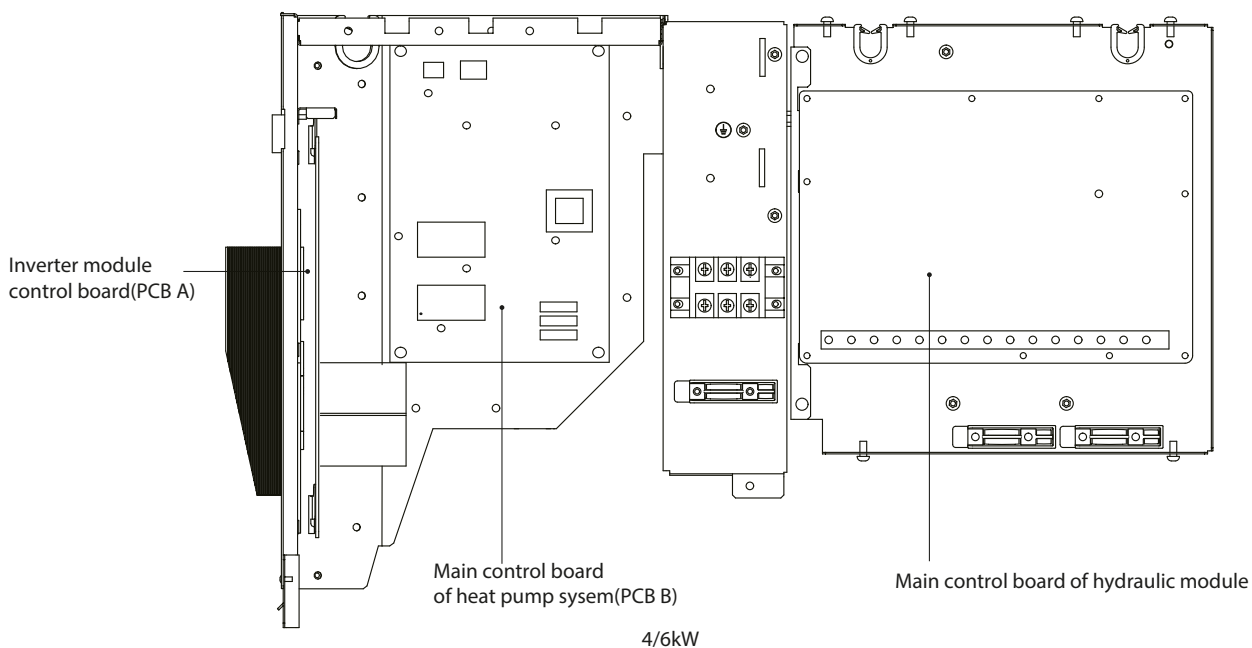

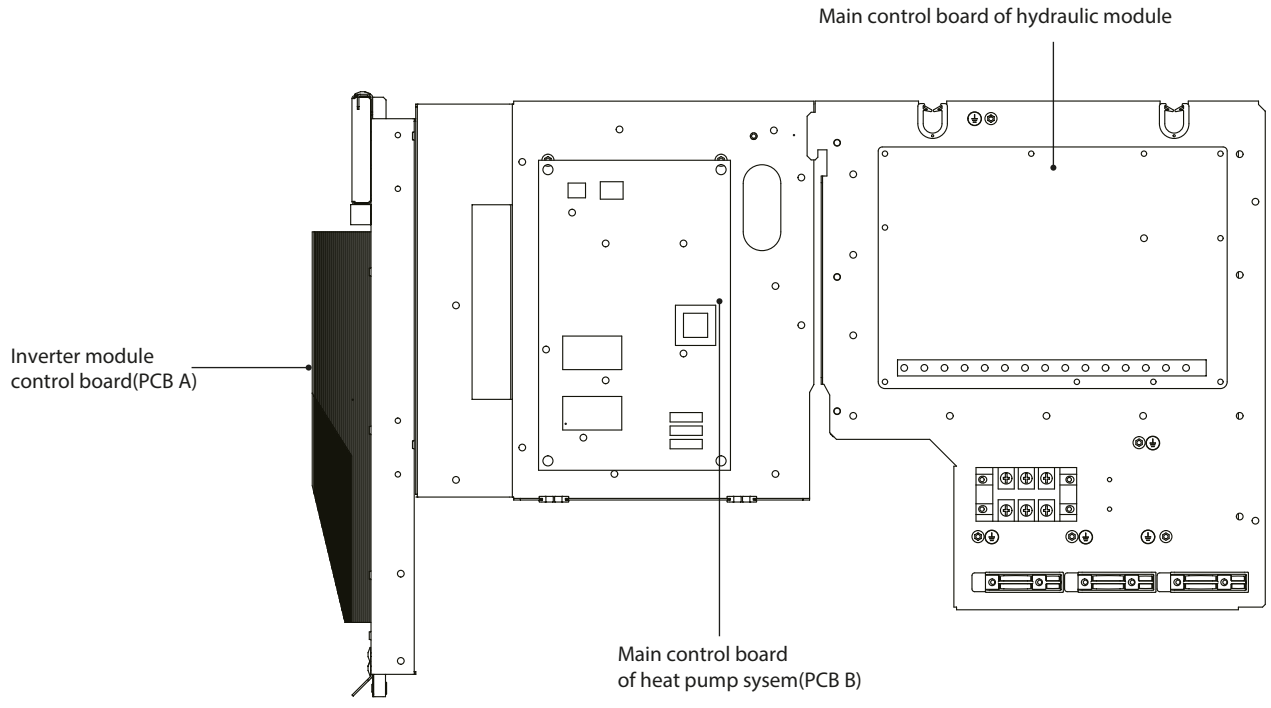

12/14/16kW(1-phase)

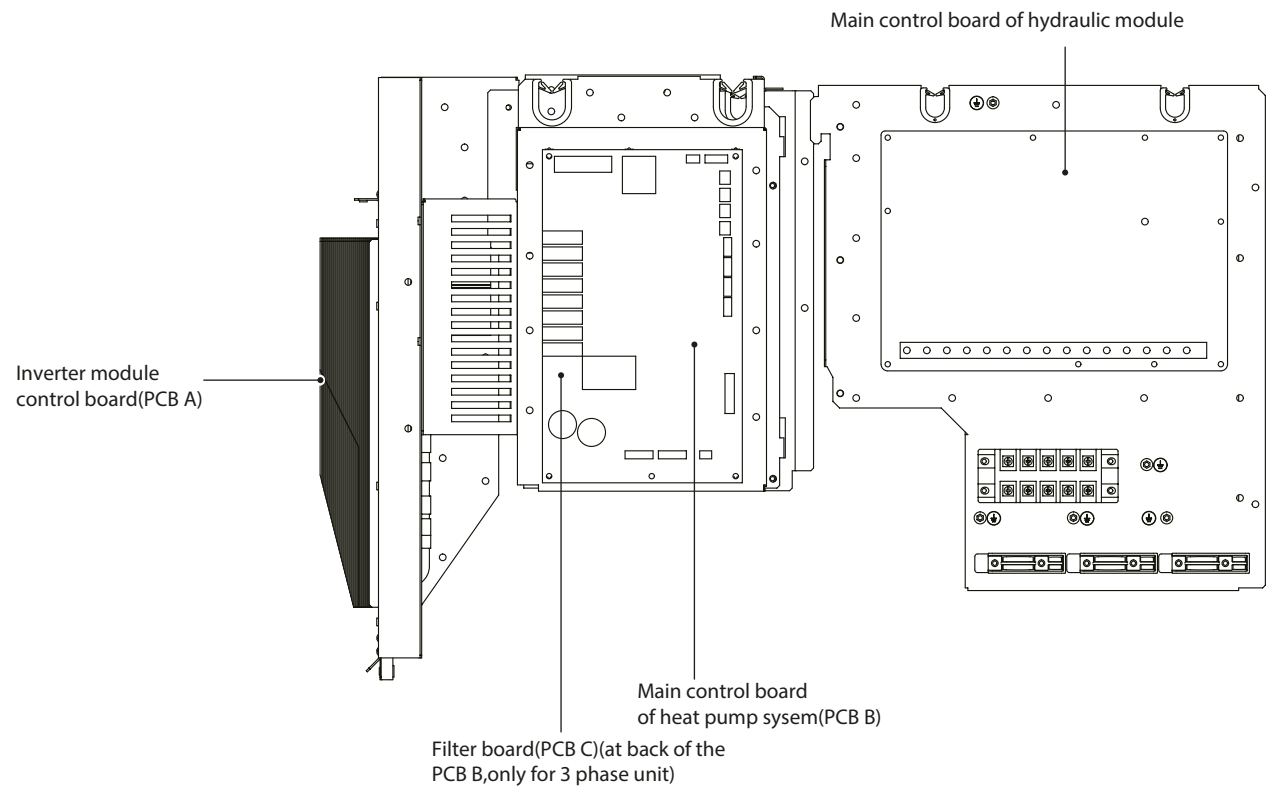

12/14/16kW(3-phase)

24	CN11	1 2	Input port for solar energy
		3 4 15	Port for room thermostat
		5 6 16	Port for SV1 (3-way valve)
		7 8 17	Port for SV2 (3-way valve)
		9 21	Port for zone2 pump
		10 22	Port for outside circulation pump
		11 23	Port for solar energy pump
		12 24	Port for DHW pipe pump
		13 16	Control port for tank booster heater
		14 17	Control port for internal backup heater 1
		18 19 20	Port for SV3 (3-way valve)
25	CN2	TBH_FB	Feedback port for external temperature switch (shorted in default)
26	CN1	IBH1/2_FB	Feedback port for temperature switch (shorted in default)
27	CN22	IBH1	Control port for internal backup heater 1
		IBH2	Reserved
		TBH	Control port for tank booster heater
28	CN41	HEAT8	Port for anti-freeze electric heating tape (internal)
29	CN40	HEAT7	Port for anti-freeze electric heating tape (internal)
30	CN42	HEAT6	Port for anti-freeze electric heating tape (internal)
31	CN29	HEAT5	Port for anti-freeze electric heating tape (internal)
32	CN32	IBH0	Port for backup heater

9.3.2 1-phase for 4-16kW units

1) PCB A, 4-10kW, Inverter module

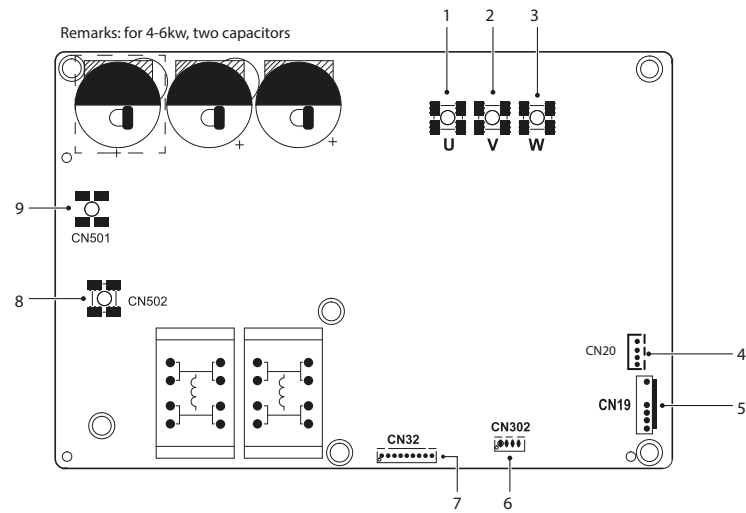

Code	Assembly unit
1	Compressor connection port U
2	Compressor connection port V
3	Compressor connection port W
4	Output port for +12V/9V(CN20)
5	Port for fan(CN19)
6	Reserved(CN302)
7	Port for communication with PCB B(CN32)
8	Input port N for rectifier bridge (CN502)
9	Input port L for rectifier bridge (CN501)

2) PCB A, 12-16kW, Inverter module

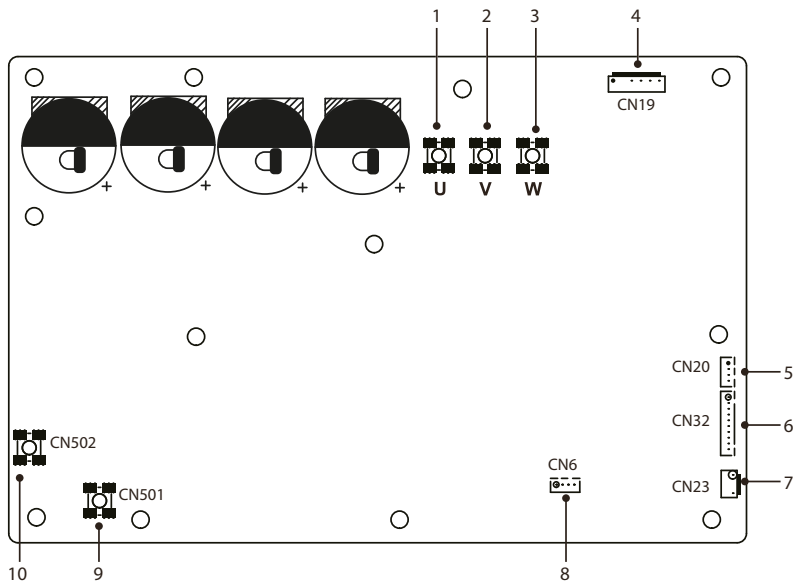

Code	Assembly unit
1	Compressor connection port U
2	Compressor connection port V
3	Compressor connection port W
4	Port for fan (CN19)
5	Output port for +12V/9V (CN20)
6	Port for communication with PCB B (CN32)
7	Port for high pressure switch (CN23)
8	Reserved (CN6)
9	Input port L for rectifier bridge (CN501)
10	Input port N for rectifier bridge (CN502)

2) PCB B, Main control board of heat pump system

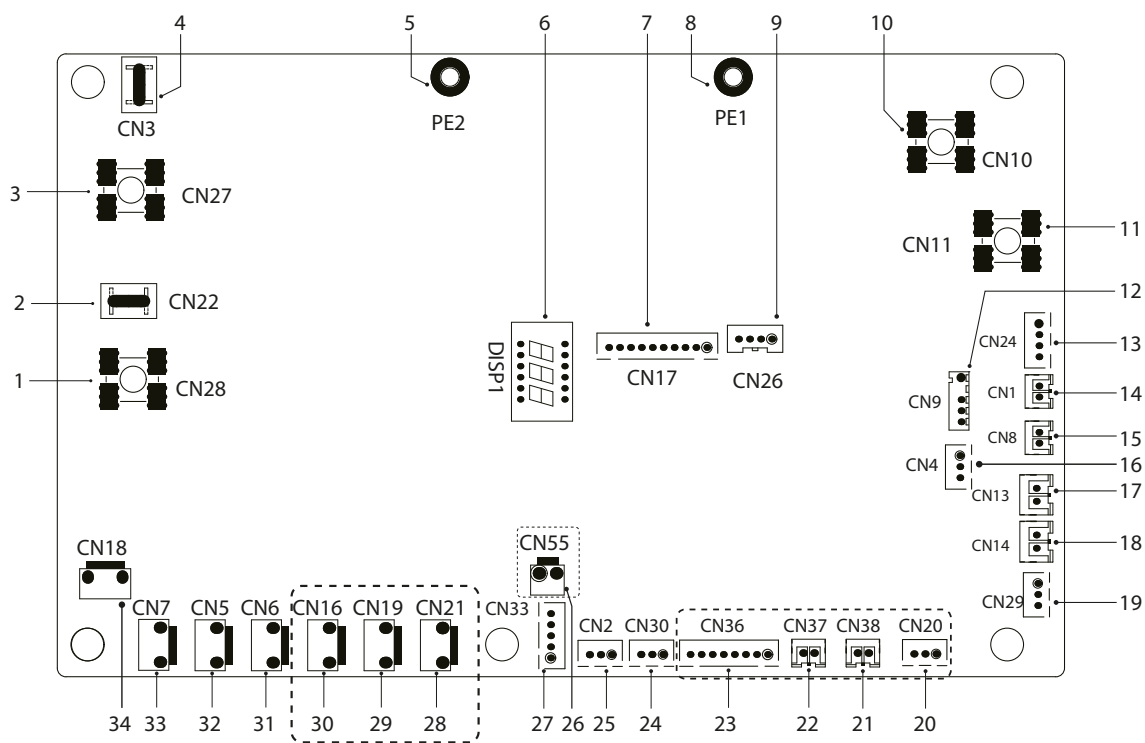

Code 1	Assembly unit	Code 1	Assembly unit
1	Output port L to PCB A (CN28)	18	Port for low pressure switch (CN14)
2	Reserved (CN22)	19	Port for communication with hydro-box control board (CN29)
3	Output port N to PCB A (CN27)	20	Reserved (CN20)
4	Reserved (CN3)	21	Reserved (CN38)
5	Port for ground wire (PE2)	22	Reserved (CN37)
6	Digital display (DSP1)	23	Reserved (CN36)
7	Port for communication with PCB A (CN17)	24	Port for communication (reserved,CN30)
8	Port for ground wire (PE1)	25	Port for communication (reserved,CN2)
9	Reserved (CN26)	26	Reserved (CN55)
10	Input port for neutral wire (CN10)	27	Port for electrical expansion valve (CN33)
11	Input port for live wire (CN11)	28	Reserved (CN21)
12	Port for outdoor ambient temp. sensor and condenser temp. sensor (CN9)	29	Reserved (CN19)
13	Input port for +12V/9V (CN24)	30	Port for chassis electrical heating tape (CN16) (optional)
14	Port for suction temp.sensor (CN1)	31	Port for 4-way valve (CN6)
15	Port for discharge temp.sensor (CN8)	32	Port for SV6 valve (CN5)
16	Port for pressure sensor (CN4)	33	Port for compressor electric heating tape 1 (CN7)
17	Port for high pressure switch (CN13)	34	Port for compressor electric heating tape 2 (CN18)

9.3.3 3-phase for 12/14/16 kW units

1) PCB A, Inverter module

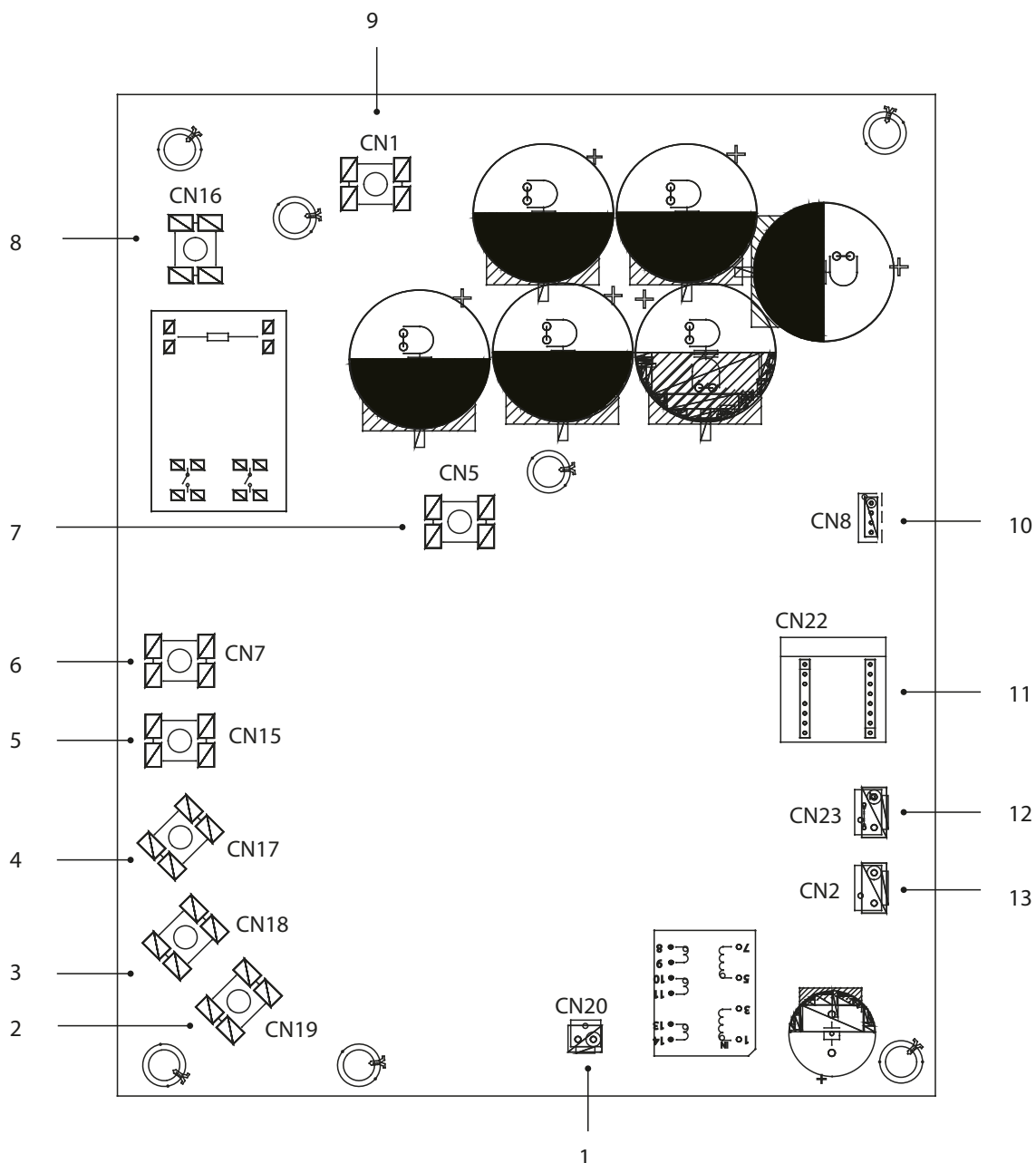

Code	Assembly unit	Code	Assembly unit
1	Output port for +15V (CN20)	8	Power Input port L1 (CN16)
2	Compressor connection port W (CN19)	9	Input port P_in for IPM module (CN1)
3	Compressor connection port V (CN18)	10	Port for communication with PCB B (CN8)
4	Compressor connection port U (CN17)	11	PED board (CN22)
5	Power Input port L3 (CN15)	12	Port for high pressure switch (CN23)
6	Power Input port L2 (CN7)	13	Port for communication with PCB C (CN2)
7	Input port P_out for IPM module (CN5)		

2) PCB B, Main control board of heat pump system

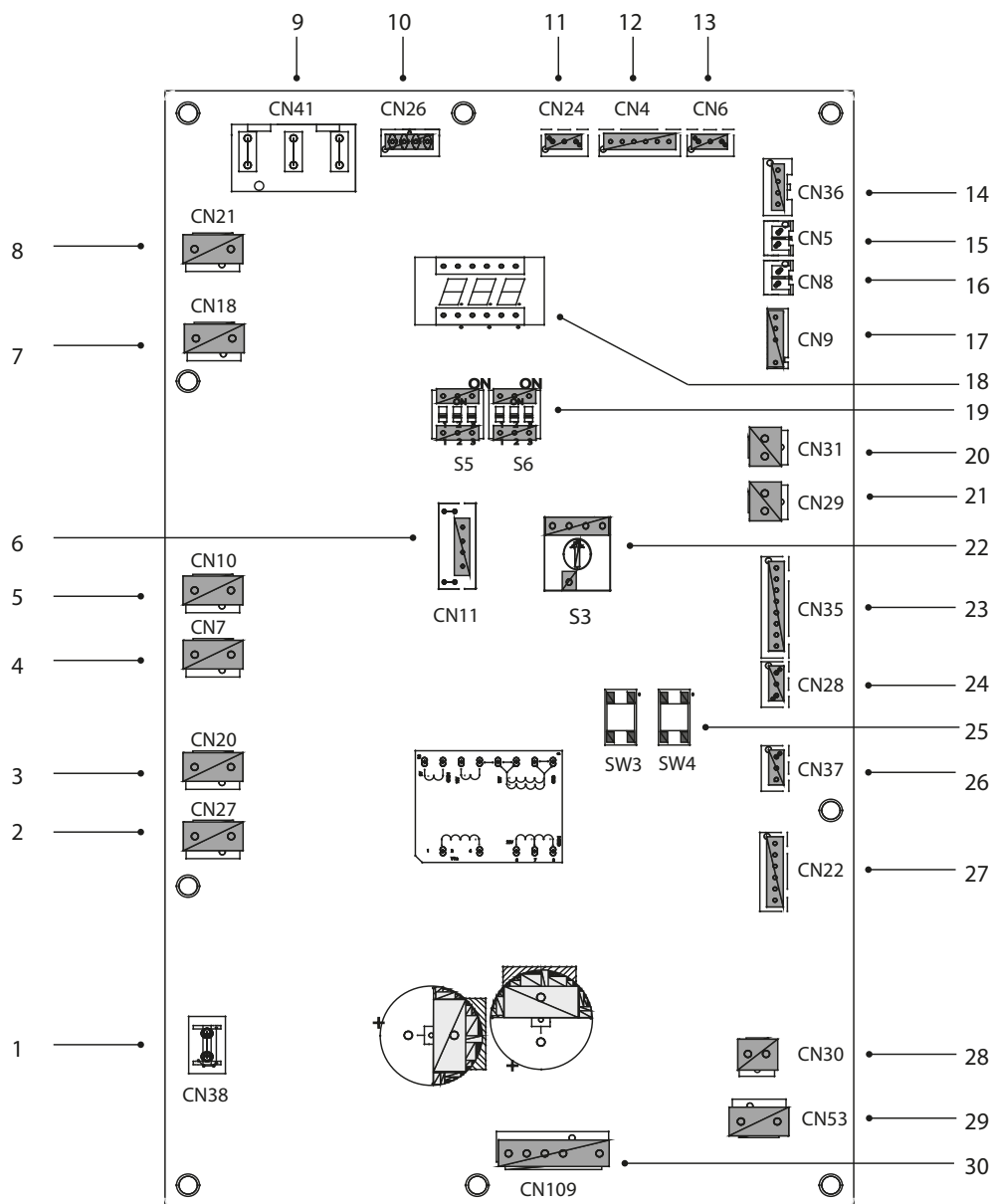

Code	Assembly unit	Code	Assembly unit
1	Port for ground wire (CN38)	16	Port for temp.sensor Tp (CN8)
2	Port for 2-way valve 6 (CN27)	17	Port for outdoor ambient temp. sensor and condenser temp.sensor (CN9)
3	Port for 2-way valve 5 (CN20)	18	Digital display (DSP1)
4	Port for electric heating tape2 (CN7)	19	DIP switch (S5,S6)
5	Port for electric heating tape1 (CN10)	20	Port for low pressure switch (CN31)
6	Reserved (CN11)	21	Port for high pressure switch and quick check (CN29)
7	Port for 4-way valve (CN18)	22	Rotary dip switch (S3)
8	Reserved (CN21)	23	Port for temp.sensors (TW_out, TW_in, T1, T2, T2B) (CN35) (Reserved)
9	Power supply port from PCB C (CN41)	24	Port for communication XYE (CN28)
10	Port for communication with Power Meter (CN26)	25	Key for force cool&check (S3,S4)
11	Port for communication with hydro-box control board (CN24)	26	Port for communication H1H2E (CN37)
12	Port for communication with PCB C (CN4)	27	Port for electrical expansion valve (CN22)
13	Port for pressure sensor (CN6)	28	Port for fan 15VDC power supply (CN30)
14	Port for communication with PCB A (CN36)	29	Port for fan 310VDC power supply (CN53)
15	Port for temp.sensor Th (CN5)	30	Port for fan (CN109)

3) PCB C, filter board

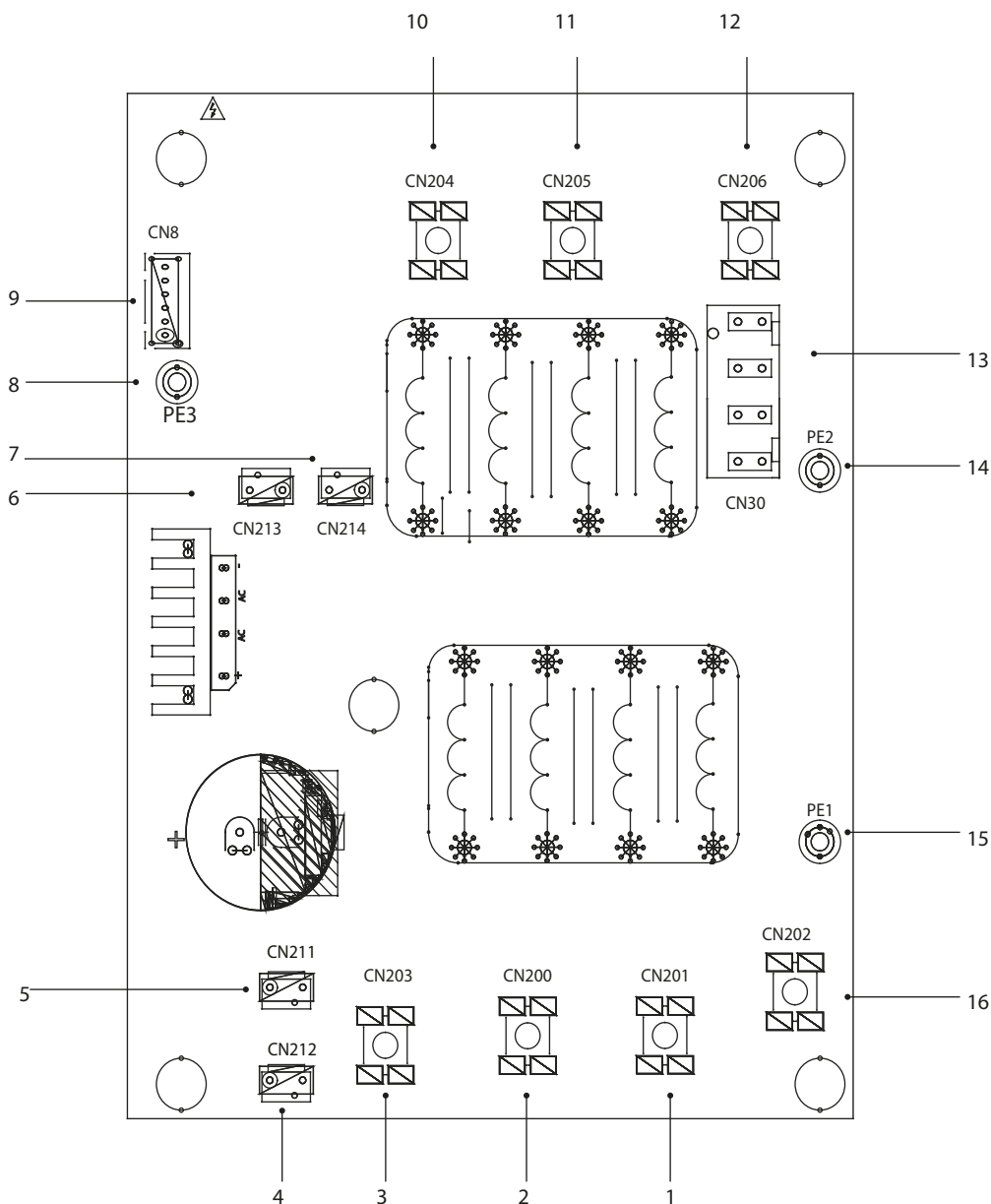

Code	Assembly unit	Code	Assembly unit
1	Power supply L2 (CN201)	9	Port for communication with PCB B (CN8)
2	Power supply L3 (CN200)	10	Power filtering L3 (L3)
3	Power supply N (CN203)	11	Power filtering L2 (L2)
4	Power supply port of 310VDC (CN212)	12	Power filtering L1 (L1)
5	Reserved (CN211)	13	Power supply port for main control board (CN30)
6	Port for FAN Reactor (CN213)	14	Port for ground wire (PE2)
7	Power supply port for Inverter module (CN214)	15	Port for ground wire (PE1)
8	Ground wire (PE3)	16	Power supply L1 (L1)

9.4 Water piping

All piping lengths and distances have been taken into consideration.

Requirements

The maximum allowed thermistor cable length is 20m. This is the maximum allowable distance between the domestic hot water tank and the unit (only for installations with a domestic hot water tank). The thermistor cable supplied with the domestic hot water tank is 10m in length. In order to optimize efficiency we recommend installing the 3-way valve and the domestic hot water tank as close as possible to the unit.

NOTE

If the installation is equipped with a domestic hot water tank (field supply), please refer to the domestic hot water tank dedicated manual. If there is no glycol (anti-freeze), drain the system (as shown in the figure below) to prevent damage in case of power supply or pump failure.

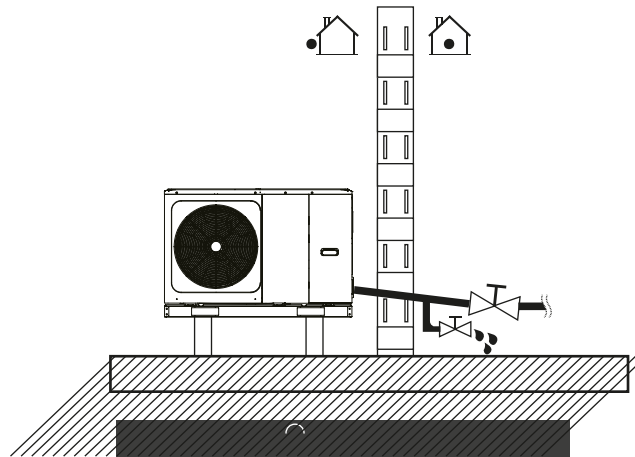

If water is not removed from the system in freezing weather when unit is not used, the frozen water may damage the water circle parts.

9.4.1 Check the water circuit

The unit is equipped with a water inlet and water outlet for connection to a water circuit. This circuit must be provided by a licensed technician and must comply with local laws and regulations.

The unit is only to be used in a closed water system. Application in an open water circuit can lead to excessive corrosion of the water piping.

Example

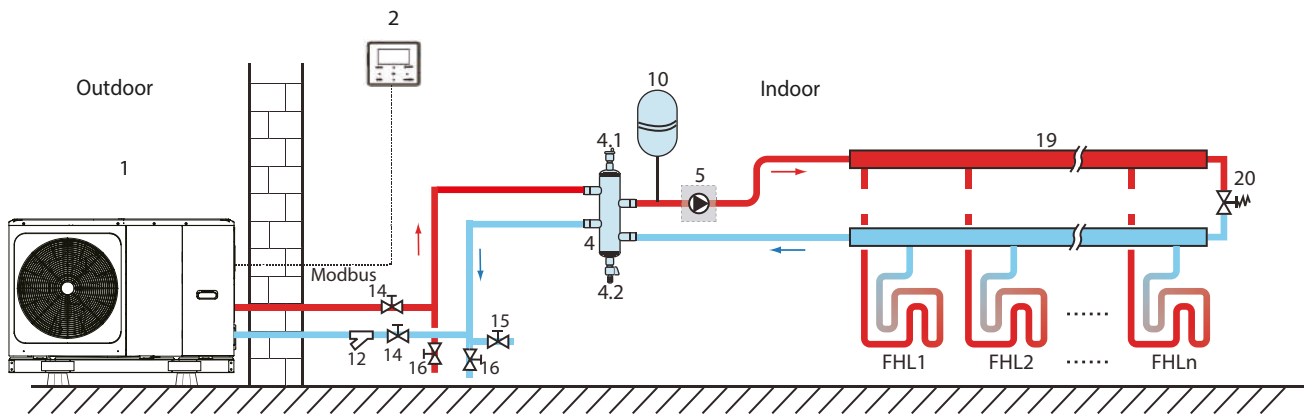

Code	Assembly unit	Code	Assembly unit
1	Main unit	12	Filter (Accessory)
2	User interface (accessory)	14	Shut-off valve (field supply)
4	Balance tank (field supply)	15	Filling valve (field supply)
4.1	Automatic air purge valve	16	Drainage valve (field supply)
4.2	Drainage valve	19	Collector/distributor (field supply)
5	PUMP O: Outside circulation pump (field supply)	20	Bypass valve (field supply)
10	Expansion vessel (field supply)	FHL 1...n	Floor heating loop (field supply)

Before continuing installation of the unit, check the following:

- The maximum water pressure ≤ 3 bar.
- The maximum water temperature $\leq 70^{\circ}\text{C}$ according to safety device setting.
- Always use materials that are compatible with the water used in the system and with the materials used in the unit.
- Ensure that components installed in the field piping can withstand the water pressure and temperature.
- Drain taps must be provided at all low points of the system to permit complete drainage of the circuit during maintenance.
- Air vents must be provided at all high points of the system. The vents should be located at points that are easily accessible for service. An automatic air purge valve is provided inside the unit. Check that this air purge valve is not tightened so that automatic release of air in the water circuit is possible.

9.4.2 Water volume and sizing expansion vessels

The units are equipped with an expansion vessel of 8l that has a default pre-pressure of 1.5 bar. To assure proper operation of the unit, the pre-pressure of the expansion vessel might need to be adjusted.

1) Check that the total water volume in the installation, excluding the **internal water volume of the unit, is at least 40l**. See 14 "Technical specifications" to find the total internal water volume of the unit (in case of cascade units, refer to the table in paragraph 8.4).



NOTE

- In most applications this minimum water volume will be satisfactory.
- In critical processes or in rooms with a high heat load though, extra water might be required.
- When circulation in each space heating loop is controlled by remotely controlled valves, it is important that this minimum water volume is kept even if all the valves are closed.

2) Expansion vessel volume must fit the total water system volume.

3) To size the expansion for the heating and cooling circuit.

The expansion vessel volume can follow the figure below:

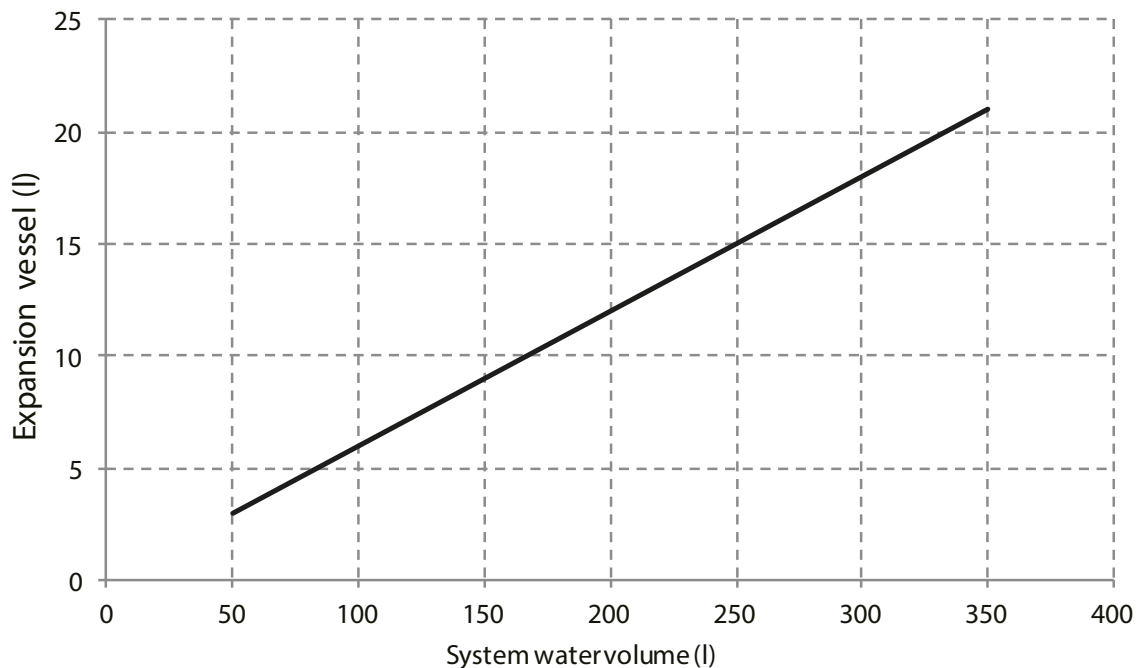

9.4.3 Water circuit connection

Water connections must be made correctly in accordance with labels on the outdoor unit, with respect to the water inlet and water outlet.

CAUTION

Be careful not to deform the unit's piping by using excessive force when connecting the piping. Deforming the piping can cause the unit to malfunction.

WARNING

It is mandatory to install a Y inlet water filter.

If air, moisture or dust gets in the water circuit, problems may occur. Therefore, always take into account the following when connecting the water circuit:

- Use clean pipes only.
- Hold the pipe end downwards when removing burrs.
- Cover the pipe end when inserting it through a wall to prevent dust and dirt entering.
- Use a good thread sealant for sealing the connections. The sealing must be able to withstand the pressures and temperatures of the system.

- When using non-copper metallic piping, be sure to insulate two kind of materials from each other to prevent galvanic corrosion.
- For copper is a soft material, use appropriate tools for connecting the water circuit. Inappropriate tools will cause damage to the pipes.

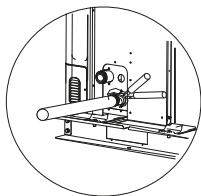

NOTE

The unit is only to be used in a closed water system. Application in an open water circuit can lead to excessive corrosion of the water piping:

- Never use Zn-coated parts in the water circuit. Excessive corrosion of these parts may occur as copper piping is used in the unit's internal water circuit.
- When using a 3-way valve in the water circuit. Preferably choose a ball type 3-way valve to guarantee full separation between the domestic hot water and floor heating water circuit.
- When using a 3-way valve or a 2-way valve in the water circuit. The recommended maximum changeover time of the valve should be less than 60 seconds.

9.4.4 Water circuit anti-freeze protection

All internal hydronic parts are insulated to reduce heat loss. Insulation must also be added to the field piping.

In event of a power failure, the above features would not protect the unit from freezing.

The software contains special functions using the heat pump and backup heater (if it is available) to protect the entire system against freezing. When the temperature of the water flow in the system drops to a certain value, the unit will heat the water, either using the heat pump, the electric heating tap, or the backup heater. The freeze protection function will turn off only when the temperature increases to a certain value.

Water may enter into the flow switch and cannot be drained out and may freeze when the temperature is low enough. The flow switch should be removed and dried, then can be reinstalled in the unit.

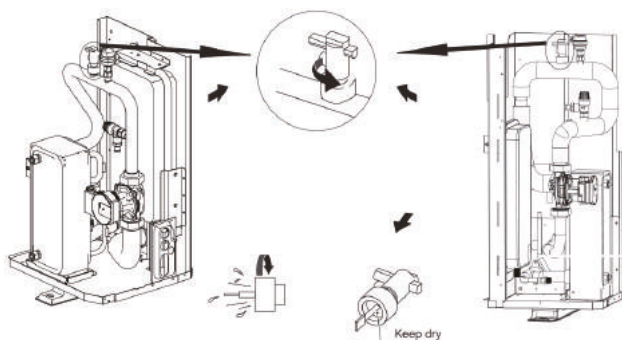

NOTE

- Counterclockwise rotation, remove the flow switch.
- Drying the flow switch completely.

CAUTION

- When the unit is not running for a long time, make sure the unit is powered on all the time. If you want to cut off the power, the water in the system pipe needs to be drained clean, avoid the unit and pipeline system be damaged by freezing. Also the power of the unit needs to be cut off after water in the system is drained off.

WARNING

Ethylene Glycol and Propylene Glycol are TOXIC

9.5 Filling water

- Connect the water supply to the filling valve and open the valve.
- Make sure the automatic air purge valve is open (at least 2 turns).

- Fill with water pressure of approximately 2.0 bar. Remove air in the circuit as much as possible using the air purge valves. Air in the water circuit could lead to malfunction of the backup electric heater.

Do not fasten the black plastic cover on the vent valve at the top side of the unit when the system is running. Open air purge valve, turn anticlockwise at least 2 full turns to release air from the system.

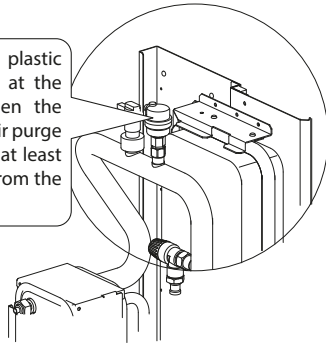

NOTE

During filling, it might not be possible to remove all air in the system. Remaining air will be removed through the automatic air purge valves during the first operating hours of the system. Topping up the water afterwards might be required.

- The water pressure will vary depending on the water temperature (higher pressure at higher water temperature). However, at all times water pressure should remain above 0.3 bar to avoid air entering the circuit.
- The unit might drain-off too much water through the pressure relief valve.
- Water quality should be complied with EN 98/83 EC Directives.
- Detailed water quality condition can be found in EN 98/83 EC Directives.

9.6 Water piping insulation

- The complete water circuit including all piping, water piping must be insulated to prevent condensation during cooling operation and reduction of the heating and cooling capacity as well as prevention of freezing of the outside water piping during winter. The insulation material should at least of B1 fire resistance rating and complies with all applicable legislation. The thickness of the sealing materials must be at least 13 mm with thermal conductivity 0.039 W/mK in order to prevent freezing on the outside water piping.
- If the outdoor ambient temperature is higher than 30°C and the humidity is higher than RH 80%, then the thickness of the sealing materials should be at least 20 mm in order to avoid condensation on the surface of the seal.

9.7 Field wiring

⚠ WARNING

A main switch or other means of disconnection, having a contact separation in all poles, must be incorporated in the fixed wiring in accordance with relevant local laws and regulations. Switch off the power supply before making any connections. Use only copper wires. Never squeeze bundled cables and make sure they do not come in contact with the piping and sharp edges. Make sure no external pressure is applied to the terminal connections. All field wiring and components must be installed by a licensed electrician and must comply with relevant local laws and regulations.

The field wiring must be carried out in accordance with the wiring diagram supplied with the unit and the instructions given below.

Be sure to use a dedicated power supply. Never use a power supply shared by another appliance.

Be sure to establish a ground. Do not ground the unit to a utility pipe, surge protector, or telephone ground. Incomplete grounding may cause electrical shock.

Be sure to install a ground fault circuit interrupter (30 mA). Failure to do so may cause electrical shock.

Be sure to install the required fuses or circuit breakers.

9.7.1 Precautions on electrical wiring work

- Fix cables so that cables do not make contact with the pipes (especially on the high pressure side).
- Secure the electrical wiring with cable ties as shown in figure so that it does not come in contact with the piping, particularly on the high-pressure side.
- Make sure no external pressure is applied to the terminal connectors.
- When installing the ground fault circuit interrupter make sure that it is compatible with the inverter (resistant to high frequency electrical noise) to avoid unnecessary opening of the ground fault circuit interrupter.

NOTE

The ground fault circuit interrupter must be a high-speed type breaker of 30 mA (<0.1 s).

- This unit is equipped with an inverter. Installing a phase advancing capacitor not only will reduce the power factor improvement effect, but also may cause abnormal heating of the capacitor due to high-frequency waves. Never install a phase advancing capacitor as it could lead to an accident.

9.7.2 Wiring overview

- The illustration below gives an overview of the required field wiring between several parts of the installation.

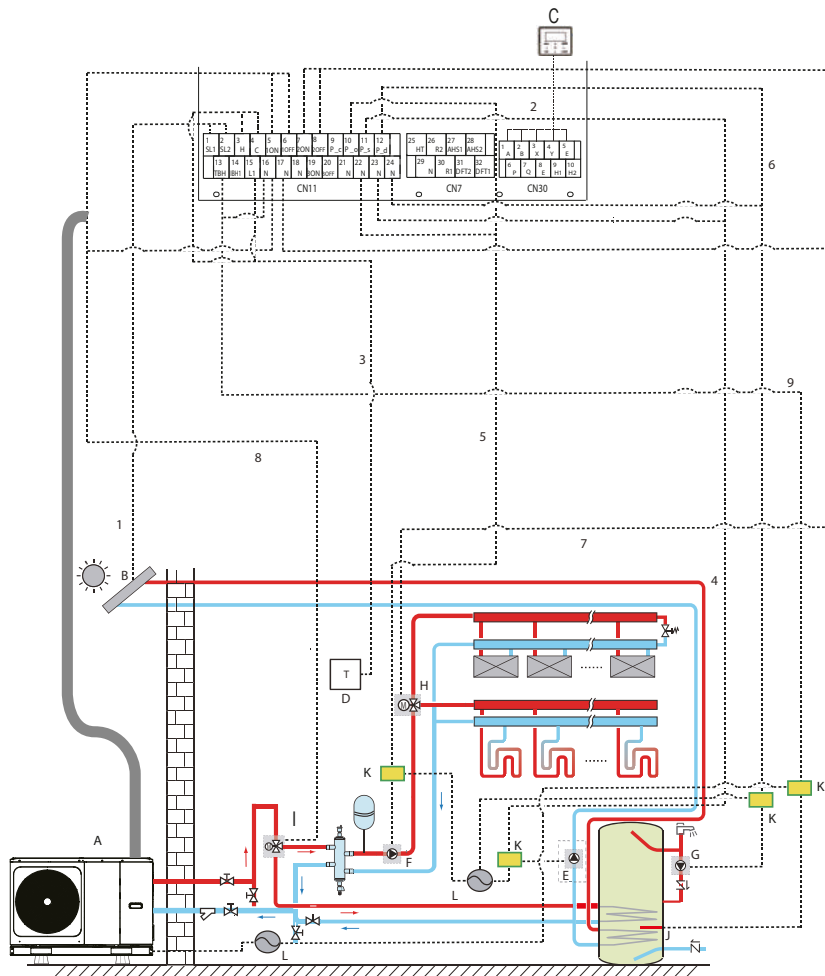

Code	Assembly unit	Code	Assembly unit
A	Main unit	G	P_d:DHW pump(field supply)
B	Solar energy kit (field supply)	H	S V 2:3-way valve(field supply)
C	User interface	I	S V 1:3-way valve for domestic hot water tank(field supply)
D	High voltage room thermostat (field supply)	J	Booster heater
E	P_s: Solar pump(field supply)	K	Contactors
F	Outside circulation pump (field supply)	L	Power supply

Item	Description	AC/DC	Required number of conductors	Maximum running current
1	Solar energy kit signal cable	AC	2	200mA
2	User interface cable	AC	5	200mA
3	Room thermostat cable	AC	2	200mA(a)
4	Solar pump control cable	AC	2	200mA(a)
5	Outside circulation pump control cable	AC	2	200mA(a)
6	DHW pump control cable	AC	2	200mA(a)
7	SV2: 3-way valve control cable	AC	3	200mA(a)
8	SV1: 3-way valve control cable	AC	3	200mA(a)
9	Booster heater control cable	AC	2	200mA(a)

(a) Minimum cable section AWG18 (0.75 mm²).

(b) The thermistor cable are delivered with the unit, if the current of the load is large, an AC contactor is needed.

 **NOTE**

Please use H07RN-F for the power wire, all the cable are connect to high voltage except for thermistor cable and cable for user interface.

- Equipment must be grounded.
- All high-voltage external load, if it is metal or a grounded port, must be grounded.
- All external load current is needed less than 0.2A, if the single load current is greater than 0.2A, the load must be controlled through AC contactor.
- AHS1" "AHS2", "A1" "A2", "R1" "R2" and "DFT1" "DFT2" wiring terminal ports provide only the switch signal. Please refer to image of 9.7.6 to get the ports position in the unit.
- Expansion valve E-Heating tape, Plate heat exchanger E-Heating tape and Flow switch E-Heating tape share a control port.

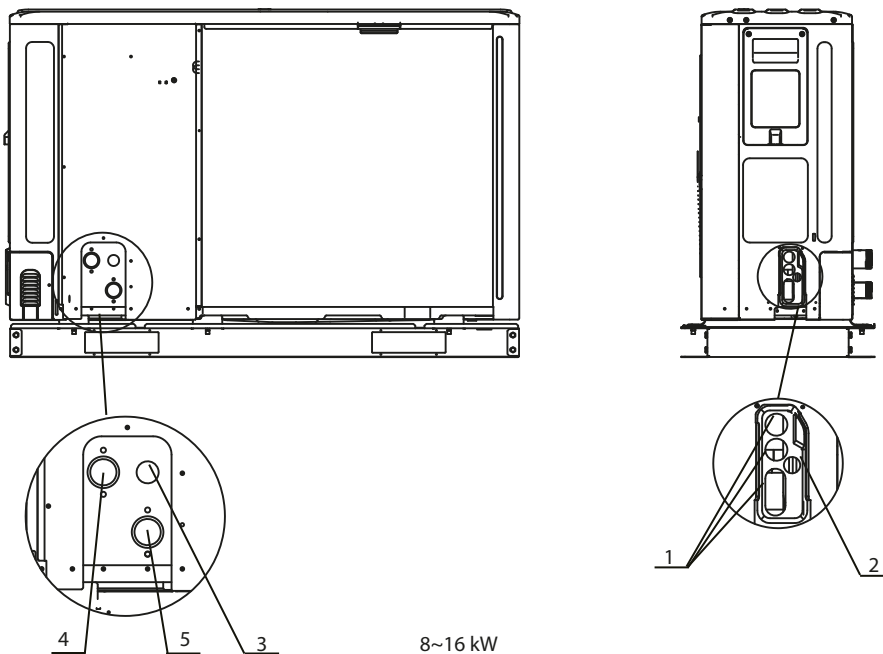
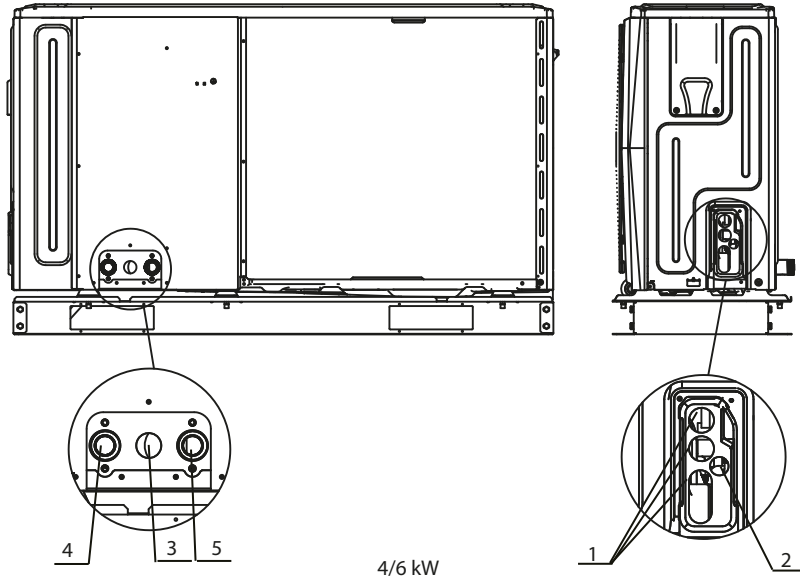

Code	Assembly unit
1	High voltage wire hole
2	Low voltage wire hole
3	Drainage pipe hole
4	Water outlet
5	Water inlet

Field wiring guidelines

- Most field wiring on the unit is to be made on the terminal block inside the switch box. To gain access to the terminal block, remove the switch box service panel (door 2).

⚠ WARNING

Switch off all power including the unit power supply and backup heater and domestic hot water tank power supply (if applicable) before removing the switch box service panel.

Fix all cables using cable ties.

A dedicated power circuit is required for the backup heater.

Installations equipped with a domestic hot water tank (field supply) require a dedicated power circuit for the booster heater. Please refer to the domestic hot water tank Installation & Owner's Manual. Secure the wiring in the order shown below.

Lay out the electrical wiring so that the front cover does not rise up when doing wiring work and attach the front cover securely.

Follow the electric wiring diagram for electrical wiring works (the electric wiring diagrams are located on the rear side of door 2).

Install the wires and fix the cover firmly so that the cover may be fit in properly.

9.7.3 Precautions on wiring of power supply

- Use a round crimp-style terminal for connection to the power supply terminal board. In case it cannot be used due to unavoidable reasons, be sure to observe the following instructions.
 - Do not connect different gauge wires to the same power supply terminal. (Loose connections may cause overheating.)
 - When connecting wires of the same gauge, connect them according to the figure below.

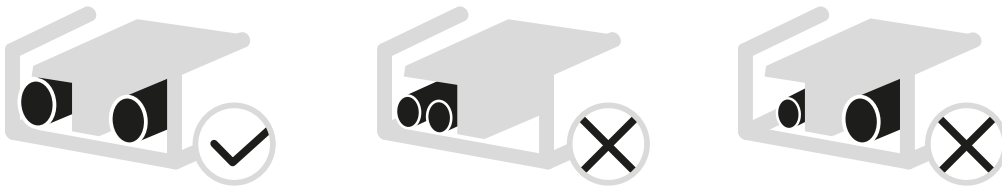

Use the correct screwdriver to tighten the terminal screws. Small screwdrivers can damage the screw head and prevent appropriate tightening.

- Over-tightening the terminal screws can damage the screws.
- Attach a ground fault circuit interrupter and fuse to the power supply line.
- In wiring, make certain that prescribed wires are used, carry out complete connections, and fix the wires so that outside force cannot affect the terminals.

9.7.4 Safety device requirement

1. Select the wire diameters(minimum value) individually for each unit based on the table 9-1 and table 9-2, where the rated current in table 9-1 means MCA in table 9-2. In case the MCA exceeds 63A, the wire diameters should be selected according to the national wiring regulation.
2. Maximum allowable voltage range variation between phases is 2%.
3. Select circuit breaker that having a contact separation in all poles not less than 3 mm providing full disconnection, where MFA is used to select the current circuit breakers and residual current operation breakers.

Rated current of appliance (A):	Nominal cross-sectional area (mm ²)	
	Flexible cords	Cable for fixed wiring
≤3	0.5 and 0.75	1 and 2.5
>3 and ≤6	0.75 and 1	1 and 2.5
>6 and ≤10	1 and 1.5	1 and 2.5
>10 and ≤16	1.5 and 2.5	1.5 and 4
>16 and ≤25	2.5 and 4	2.5 and 6
>25 and ≤32	4 and 6	4 and 10
>32 and ≤50	6 and 10	6 and 16
>50 and ≤63	10 and 16	10 and 25

Table 9-2 1-phase 4-16kW standard and 3-phase 12-16kW standard

System	Outdoor Unit				Power Current			Compressor		OFM	
	Voltage (V)	Hz	Min. (V)	Max. (V)	MCA (A)	TOCA (A)	MFA (A)	MSC (A)	RLA (A)	KW	FLA (A)
4kW	220-240	50	198	264	12	18	25	-	11,50	0,10	0,50
6kW	220-240	50	198	264	14	18	25	-	13,50	0,10	0,50
8kW	220-240	50	198	264	16	19	25	-	14,50	0,17	1,50
10kW	220-240	50	198	264	17	19	25	-	15,50	0,17	1,50
12kW	220-240	50	198	264	25	30	35	-	23,50	0,17	1,50
14kW	220-240	50	198	264	26	30	35	-	24,50	0,17	1,50
16kW	220-240	50	198	264	27	30	35	-	25,50	0,17	1,50
12kW 3-PH	380-415	50	342	456	10	14	16	-	9,15	0,17	1,50
14kW 3-PH	380-415	50	342	456	11	14	16	-	10,15	0,17	1,50
16kW 3-PH	380-415	50	342	456	12	14	16	-	11,15	0,17	1,50

NOTE

MCA : Max. Circuit Amps. (A)

TOCA : Total Over-current Amps. (A)

MFA : Max. Fuse Amps. (A)

MSC : Max. Starting Amps. (A)

RLA : In nominal cooling or heating test condition the input Amps of compressor where MAX. Hz can operate Rated Load Amps. (A)

KW : Rated Motor Output

FLA : Full Load Amps. (A)

9.7.5 Remove the switch box cover

1-phase 4-16kW standard and 3-phase 12-16kW standard										
Unit	4kW	6kW	8kW	10kW	12kW	14kW	16kW	12kW 3-PH	14kW 3-PH	16kW 3-PH
Maximum overcurrent protector(MOP)(A)	18	18	19	19	30	30	30	14	14	14
Wiring size(mm ²)	4.0	4.0	4.0	4.0	6.0	6.0	6.0	2.5	2.5	2.5

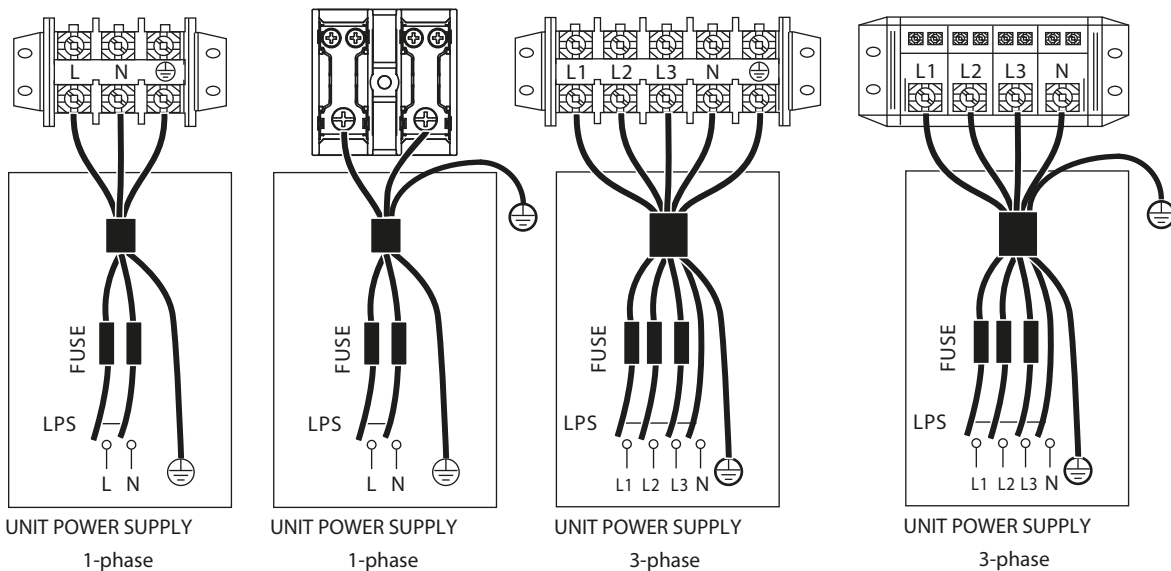

NOTE

The ground fault circuit interrupter must be 1 high-speed type of 30mA(<0.1s). Please use 3-core shielded wire.

The default of backup heater is option 3 (for 9kW backup heater). If 3kW or 6kW backup heater is needed, please ask professional installer to change the Dip switch of S1 to option 1(for 3kW backup heater) or option 2(for 6kW backup heater), refer to 10.1.1 FUNCTION SETTING.

Stated values are maximum values (see electrical data for exact values).

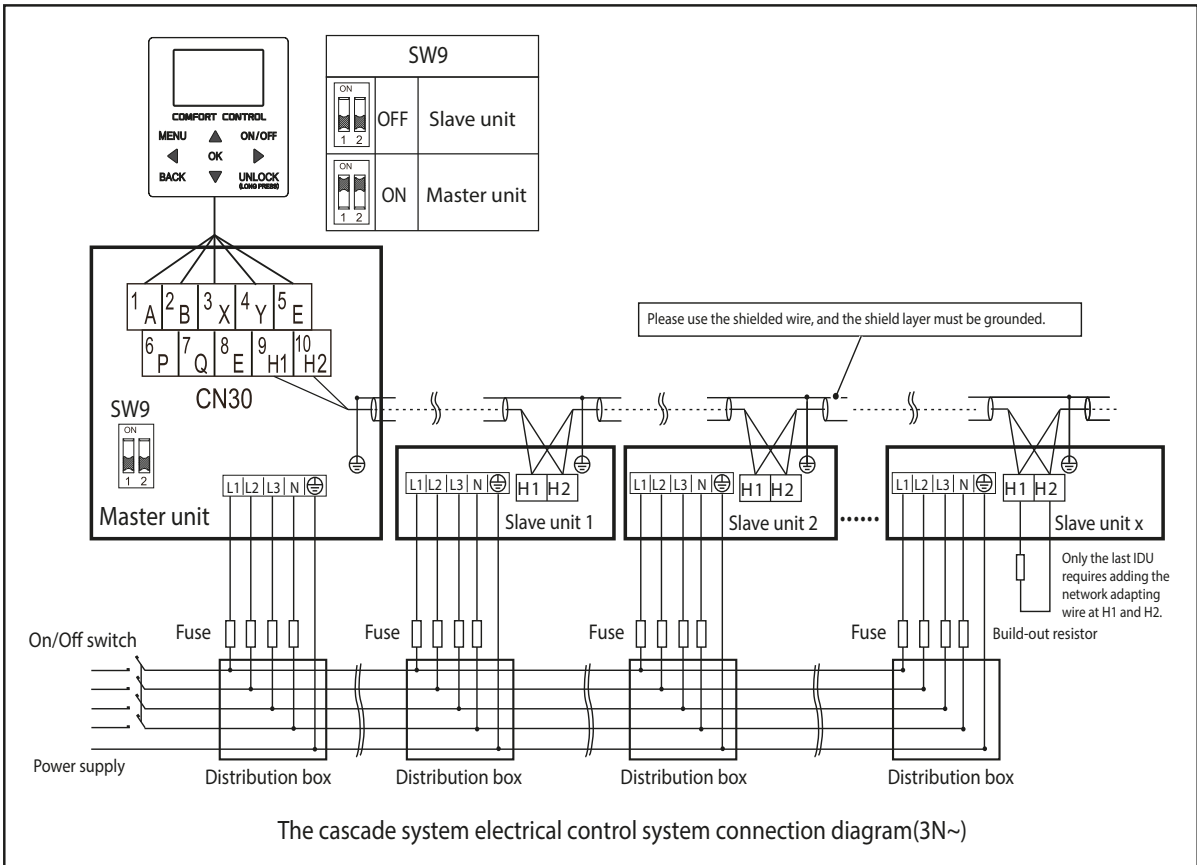
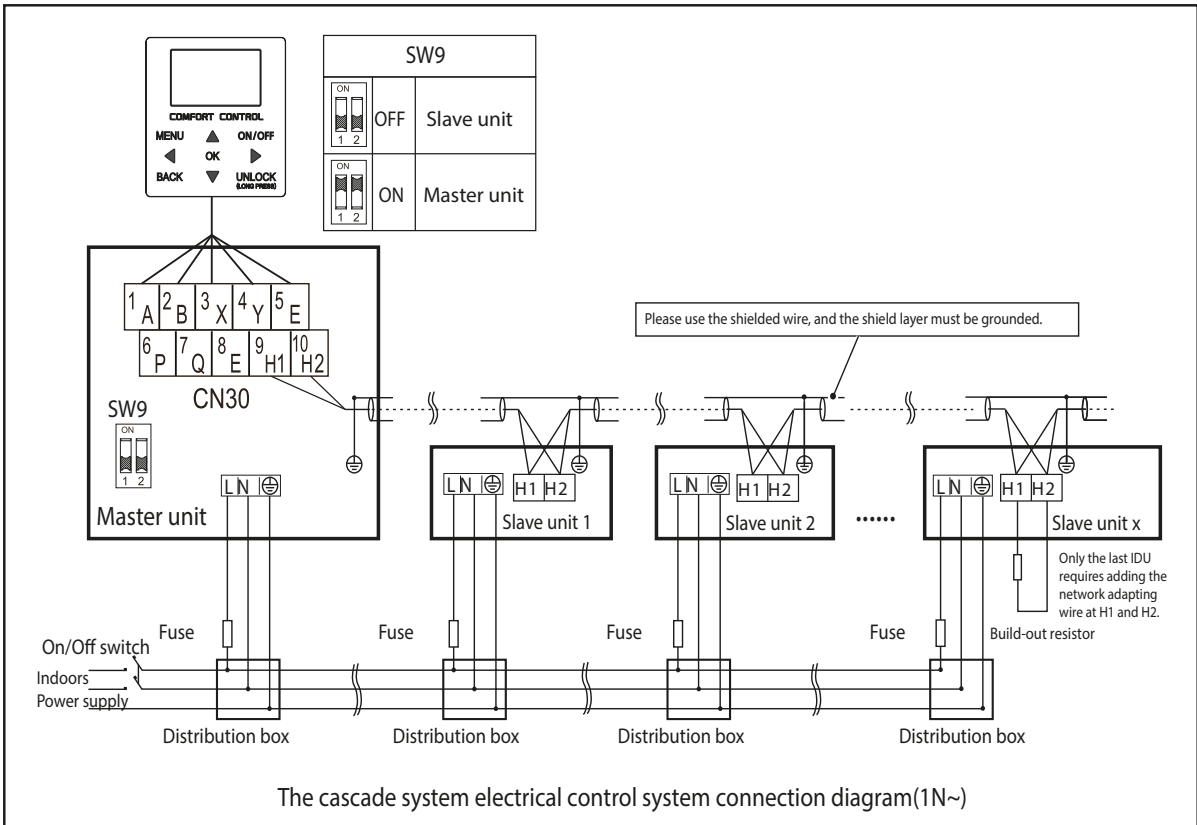

⚠ ATTENTION

- 1) The cascade function of the system only supports 6 machines at most.
- 2) In order to ensure the success of automatic addressing, all machines must be connected to the same power supply and powered on uniformly.
- 3) Only the Master unit can connect the controller, and you must put the SW9 to "on" of the master unit, the slave unit cannot connect the controller .
- 4) Please use the shielded wire, and the shield layer must be grounded.

When connecting to the power supply terminal, use the circular wiring terminal with the insulation casing (see Figure 9.1).
 If circular wiring terminal with the insulation casing cannot be used, please make sure that:
 Use power cord that conforms to the specification and connect the power cord firmly. To prevent the cord from being pulled out by external force, make sure it is fixed securely.
 If circular wiring terminal with the insulation casing cannot be used, please make sure that:

- Do not connect two power cords with different diameters to the same power supply terminal (may cause overheating of wires due to loose wiring) (See Figure 9.2).

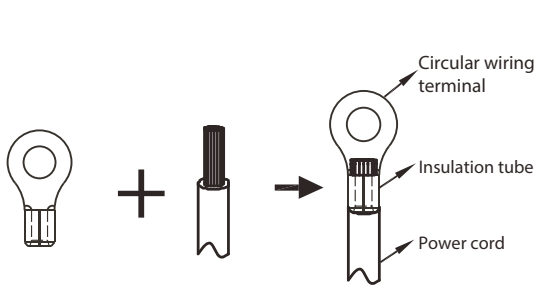

Figure 9.1

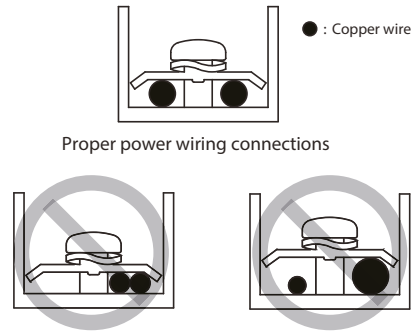

Figure 9.2

Power Cord Connection of cascade system

- Use a dedicated power supply for the indoor unit that is different from the power supply for the outdoor unit.
- Use the same power supply, circuit breaker and leakage protective device for the indoor units connected to the same outdoor unit.

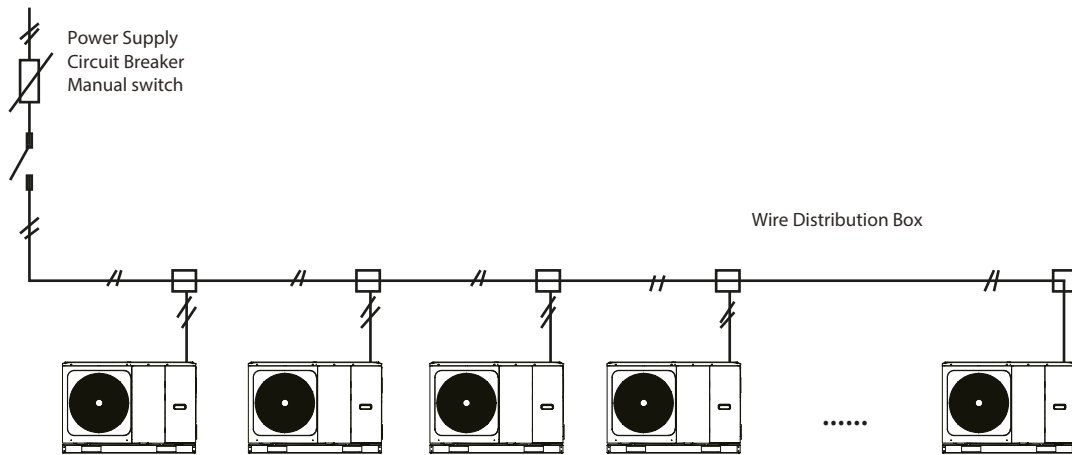
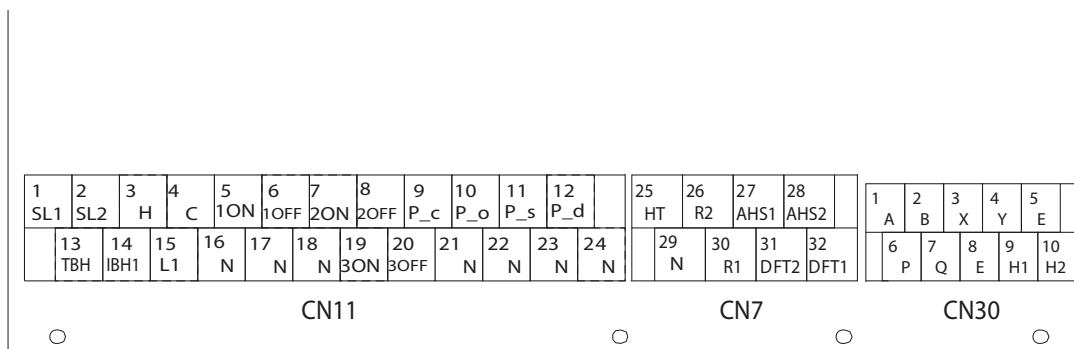

Figure 9.3

9.7.6 Connection for other components



CN11	CODE	PRINT	CONNECT TO
	1	1	SL1
2		SL2	
2	3	HL	Room thermostat input (high voltage)
	4	CL	
	15	L1	
3	5	1ON	SV1 (3-way valve)
	6	1OFF	
4	7	2ON	SV2 (3-way valve)
	8	2OFF	
5	9	PUMP C	Pumpc (zone2 pump)
	21	N	
6	10	PUMP O	Outside circulation pump /zone1 pump
	22	N	
7	11	P S	Solar energy pump
	23	N	
8	12	P D	DHW pipe pump
	24	N	
9	13	TBH	Tank booster heater
	16	N	
10	14	IBH1	Internal backup heater 1
	17	N	
11	18	N	SV3 (3-way valve)
	19	3ON	
	20	3OFF	

CN30	CODE	PRINT	CONNECT TO
	1	1	A
2		B	
3		X	
4		Y	
5		E	
2	6	P	Outdoor unit
	7	Q	
3	9	H1	Cascade connected heat pump
	10	H2	

CN7	CODE	PRINT	CONNECT TO
	1	26	R2
30		R1	
31		DFT2	Defrost run
32		DFT1	
2	25	HT	Antifreeze E-heating tape (external)
	29	N	
3	27	AHS1	Additional heat source
	28	AHS2	

Port provide the control signal to the load. Two kind of control signal port:

Type 1: Dry contact without voltage.

Type 2: Port provide the signal with 220V voltage. If the current of load is <0.2A, load can connect to the port directly.

If the current of the load is ≥0.2A, connect the load through a relay.

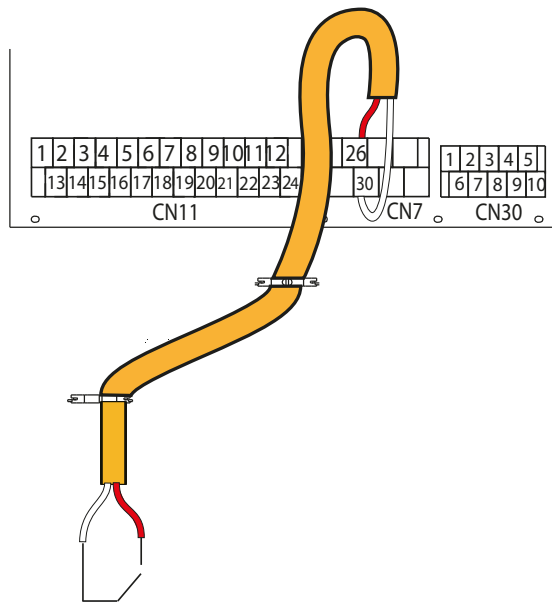

Type 1 Running

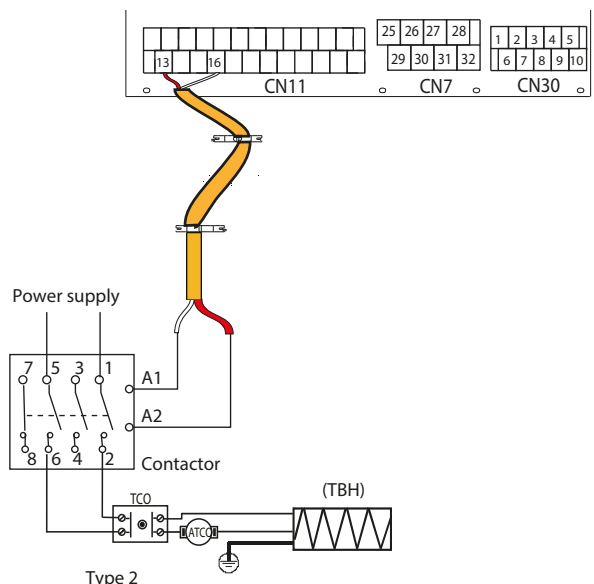

Type 2

Control signal port of hydraulic module: The CN11/CN7 contains terminals for solar energy, 3-way valve, pump, booster heater, etc.

The parts wiring is illustrated below:

1) For solar energy input signal:

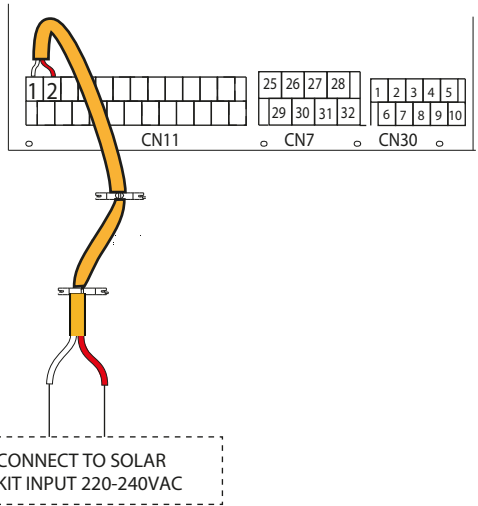

Voltage	220-240VAC
Maximum running current (A)	0.2
Wiring size(mm ²)	0.75

2) For 3-way valve SV1, SV2 and SV3:

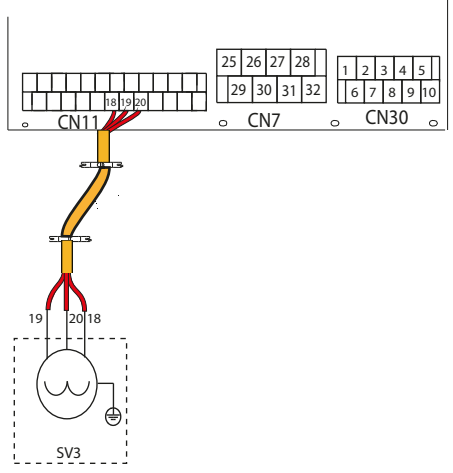
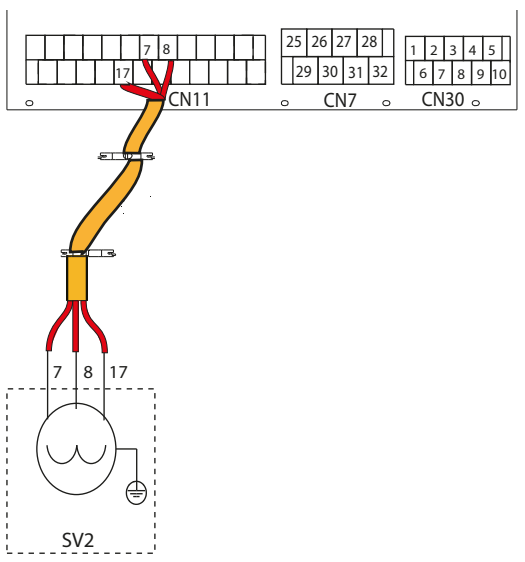
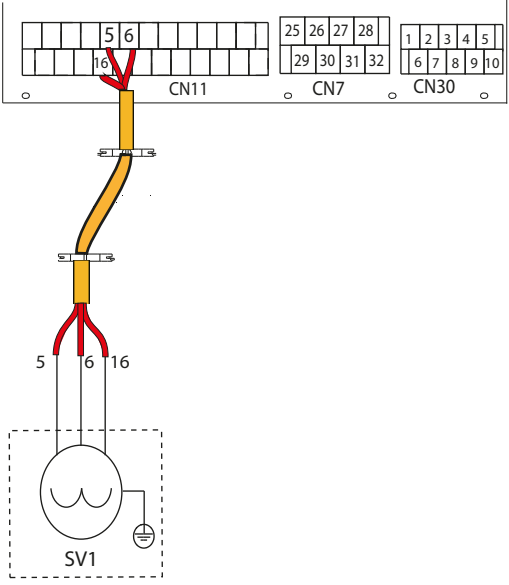

Voltage	220-240VAC
Maximum running current (A)	0.2
Wiring size(mm ²)	0.75
Control port signal type	Type 2

a) Procedure

- Connect the cable to the appropriate terminals as shown in the picture.
- Fix the cable reliably.

3) For remote shut down:

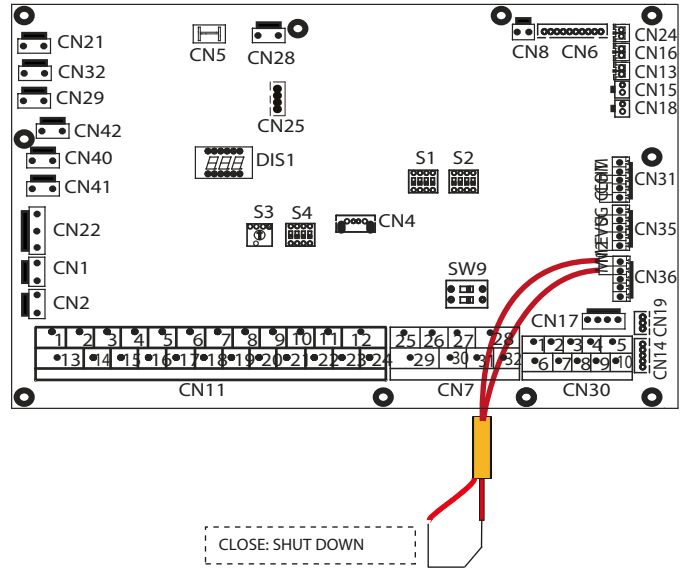

4) For Pump and DHW pipe pump:

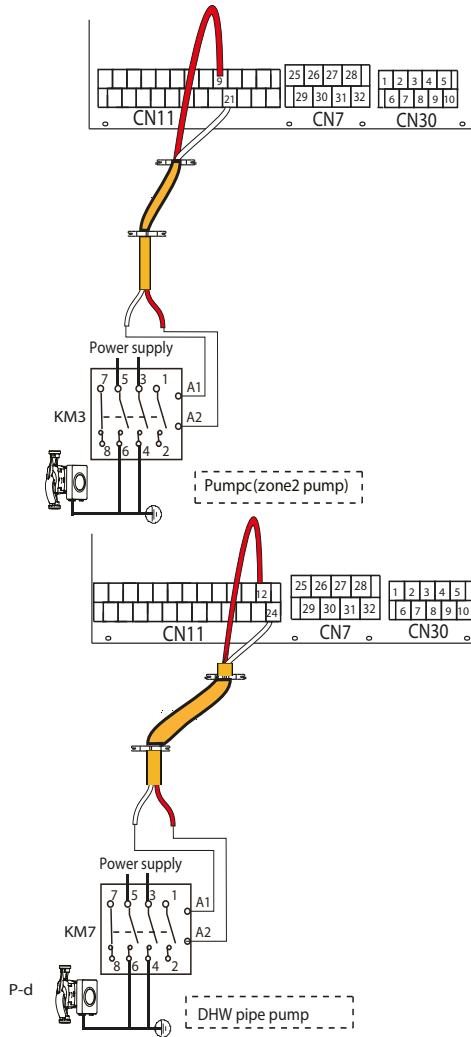

Voltage	220-240VAC
Maximum running current(A)	0.2
Wiring size(mm2)	0.75
Control port signal type	Type 2

a) Procedure

- Connect the cable to the appropriate terminals as shown in the picture. Fix the cable reliably.

5) For room thermostat:

Room thermostat type 1 (High voltage): "POWER IN" provide the working voltage to the RT, doesn't provide the voltage to the RT connector directly. Port "15 L1" provide the 220V voltage to the RT connector. Port "15 L1" connect from the unit main power supply port L of 1- phase power supply.

Room thermostat type 2 (Low voltage): "POWER IN" provide the working voltage to the RT.

NOTE

There are two optional connect method depend on the room thermostat type.

Room thermostat type 1 (High voltage):

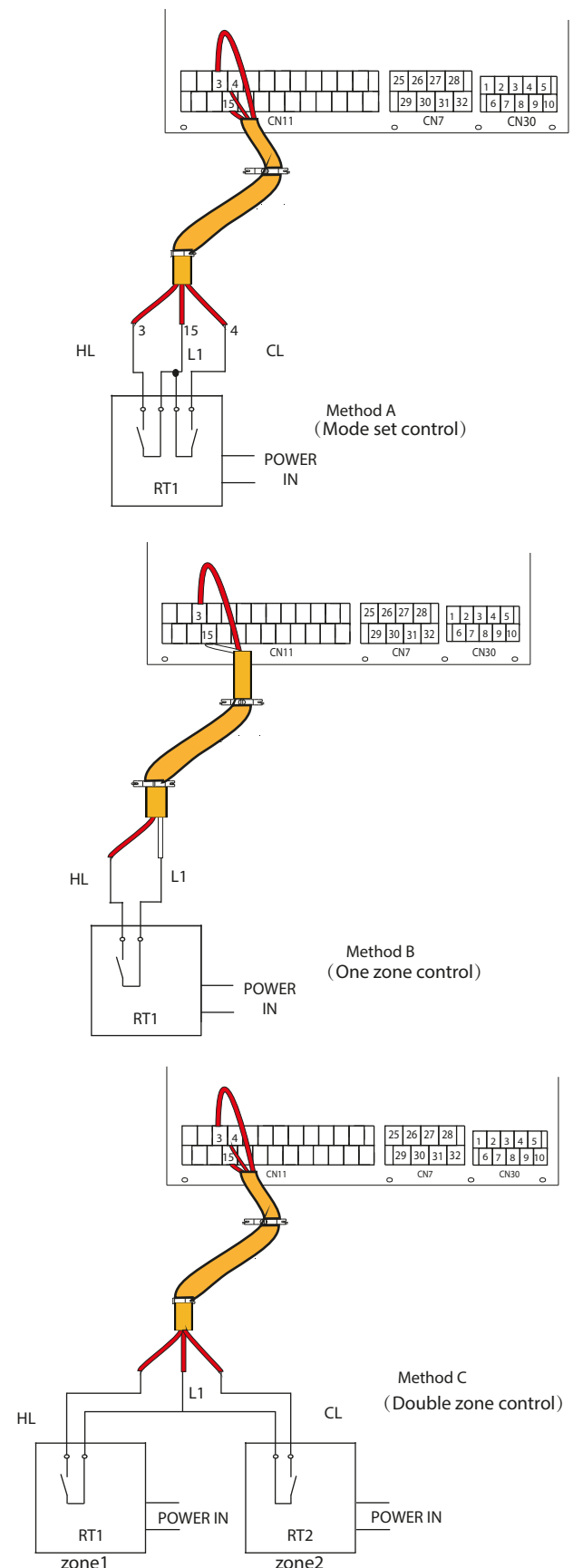

Voltage	220-240VAC
Maximum running current(A)	0.2
Wiring size(mm2)	0.75

There are three methods for connecting the thermostat cable (as described in the picture above) and it depends on the application.

Method A (mode set control)

RT can control heating and cooling individually, like the controller for 4-pipe FCU. When the hydraulic module is connected with the external temperature controller, user interface FOR SERVICEMAN set ROOM THERMOSTAT to MODE SET:

- A.1 When unit detect voltage is 230VAC between CL and L1 ,the unit operates in the cooling mode.
- A.2 When unit detect voltage is 230VAC between HL and L1, the unit operates in the heating mode.
- A.3 When unit detect voltage is 0VAC for both side (CL-L1, HL-L1) the unit stop working for space heating or cooling.
- A.4 When unit detect voltage is 230VAC for both side (CL-L1, HL-L1) the unit working in cooling mode.

Method B (one zone control)

RT provide the switch signal to unit. User interface FOR SERVICEMAN set ROOM THERMOSTAT to ONE ZONE:

- B.1 When unit detect voltage is 230VAC between HL and L1, unit turns on.
- B.2 When unit detect voltage is 0VAC between HL and L1, unit turns off.

Method C: Double zone control:

Hydraulic Module is connected with two room thermostat, while user interface FOR SERVICEMAN set ROOM THERMOSTAT to DOUBLE ZONE:

- C.1 When unit detect voltage is 230VAC between HL and L1 ,zone1 turns on.When unit detect voltage is 0VAC between HL and L1, zone1 turns off.
- C.2 When unit detect voltage is 230VAC between CL and L1, zone2 turns on according to climate temp curve. When unit detect voltage is 0V between CL and L1, zone2 turns off.
- C.3 When HL-L1 and CL-L1 are detected as 0VAC, unit turns off.
- C.4 when HL-L1 and CL-L1 are detected as 230VAC, both zone1 and zone2 turn on.

Room thermostat type2 (Low voltage):

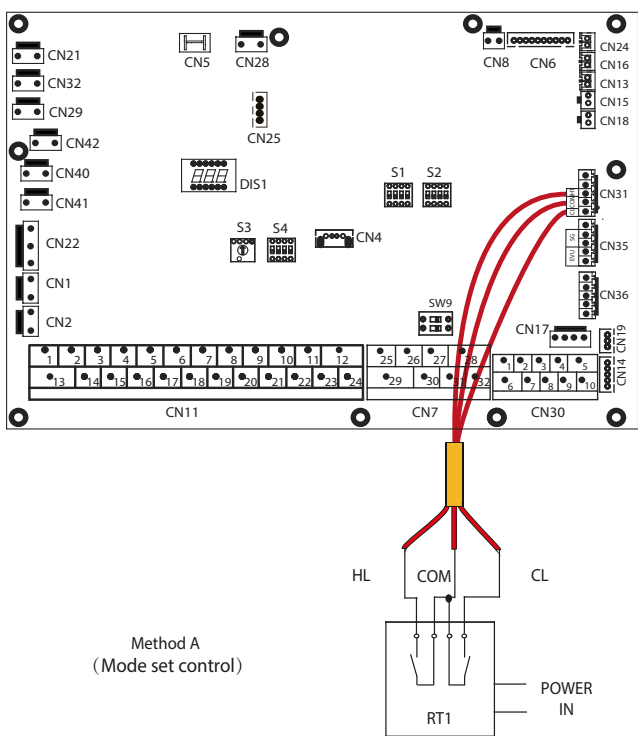

Method A (Mode set control)

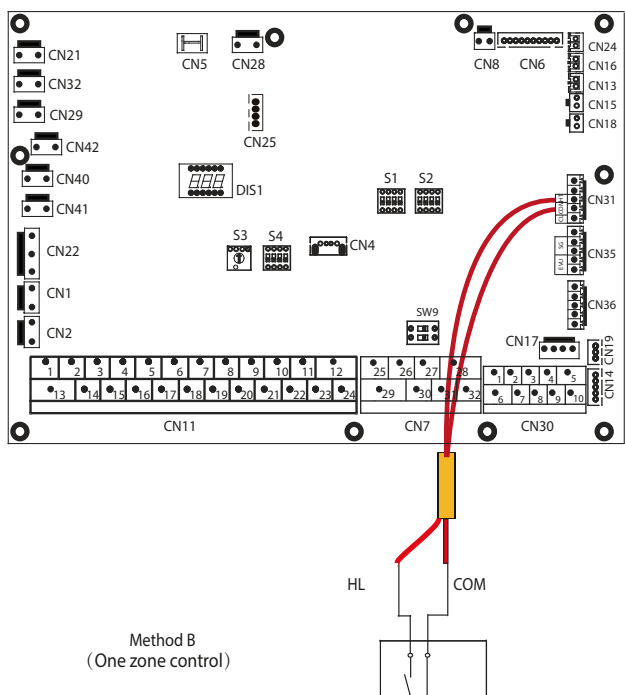

Method B (One zone control)

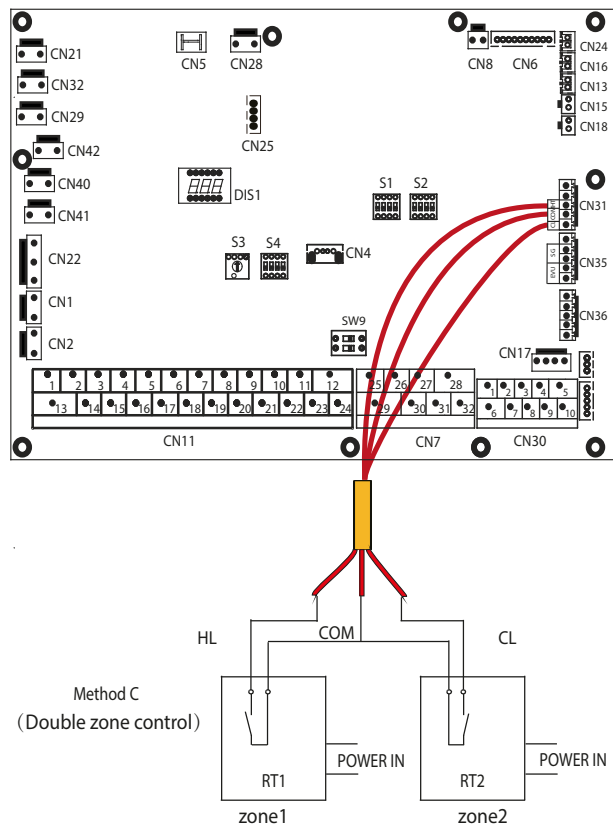

Method C (Double zone control)

There are three methods for connecting the thermostat cable (as described in the picture above) and it depends on the application.

Method A (mode set control)

RT can control heating and cooling individually, like the controller for 4-pipe FCU. When the hydraulic module is connected with the external temperature controller, user interface FOR SERVICEMAN set ROOM THERMOSTAT to MODE SET:

- A.1 When unit detect voltage is 12VDC between CL and COM ,the unit operates in the cooling mode.
- A.2 When unit detect voltage is 12VDC between HL and COM, the unit operates in the heating mode.
- A.3 When unit detect voltage is 0VDC for both side (CL-COM, HL-COM) the unit stop working for space heating or cooling.
- A.4 When unit detect voltage is 12VDC for both side (CL-COM, HL-COM) the unit working in cooling mode.

Method B (one zone control)

RT provide the switch signal to unit. User interface FOR SERVICEMAN set ROOM THERMOSTAT to ONE ZONE:

- B.1 When unit detect voltage is 12VDC between HL and COM, unit turns on.
- B.2 When unit detect voltage is 0VDC between HL and COM, unit turns off.

Method C (double zone control)

Hydraulic Module is connected with two room thermostat, while user interface FOR SERVICEMAN set ROOM THERMOSTAT to DOUBLE ZONE:

- C.1 When unit detect voltage is 12VDC between HL and COM, zone1 turn on. When unit detect voltage is 0VDC between HL and COM, zone1 turn off.
- C.2 When unit detect voltage is 12VDC between CL and COM, zone2 turn on according to climate temp curve. When unit detect voltage is 0V between CL and COM, zone2 turn off.
- C.3 When HL-COM and CL-COM are detected as 0VDC, unit turn off.
- C.4 When HL-COM and CL-COM are detected as 12VDC, both zone1 and zone2 turn on.

NOTE

- The wiring of the thermostat should correspond to the settings of the user interface. Refer to 10.5.6 "Room Thermostat".

- Power supply of machine and room thermostat must be connected to the same Neutral Line .
- When ROOM THERMOSTAT is not set to NON, the indoor temperature sensor Ta can't be set to valid.
- Zone 2 can only operate in heating mode. When cooling mode is set on user interface and zone1 is OFF, "CL" in zone2 closes, system still keeps 'OFF'. While installation, the wiring of thermostats for zone1 and zone2 must be correct.

a) Procedure

Connect the cable to the appropriate terminals as shown in the picture.

Fix the cable with cable ties to the cable tie mountings to ensure stress relief.

6) For tank booster heater:

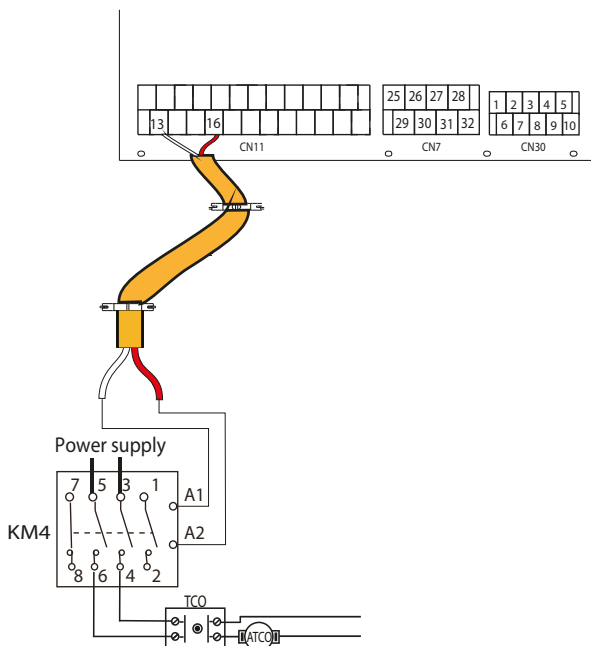

Voltage	220-240VAC
Maximum running current(A)	0.2
Wiring size(mm2)	0.75
Control port signal type	Type 2

NOTE

The unit only sends an ON/OFF signal to the heater.

7) For additional heat source control

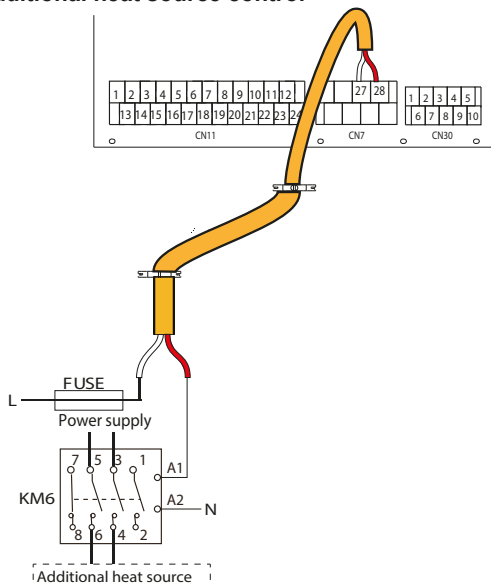

Voltage	220-240VAC
Maximum running current (A)	0.2
Wiring size (mm2)	0.75
Control port signal type	Type 2

WARNING

This part only applies to Basic. For Customized, cause there is an interval backup heater in the unit (if present), the hydraulic module should not be connected to any additional heat source

8) For defrosting signal output:

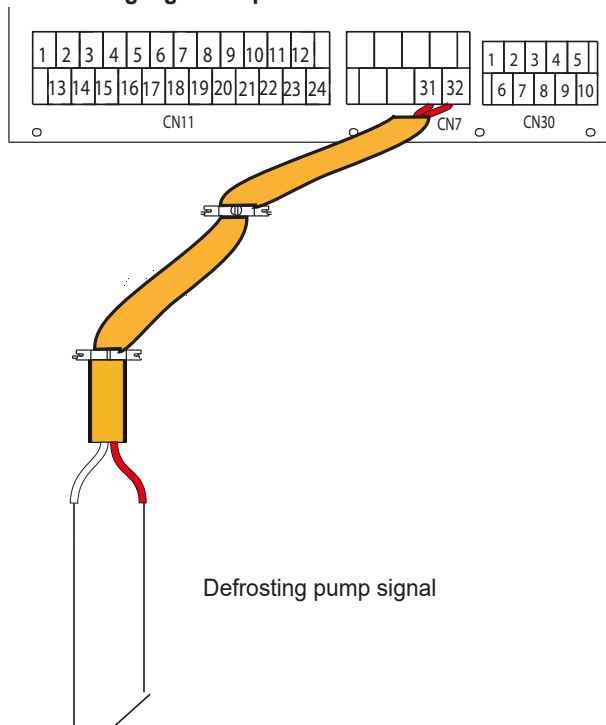

Voltage	220-240VAC
Maximum running current(A)	0.2
Wiring size(mm2)	0.75
Control port signal type	Type 1

9) For outside circulation pump PUMP O:

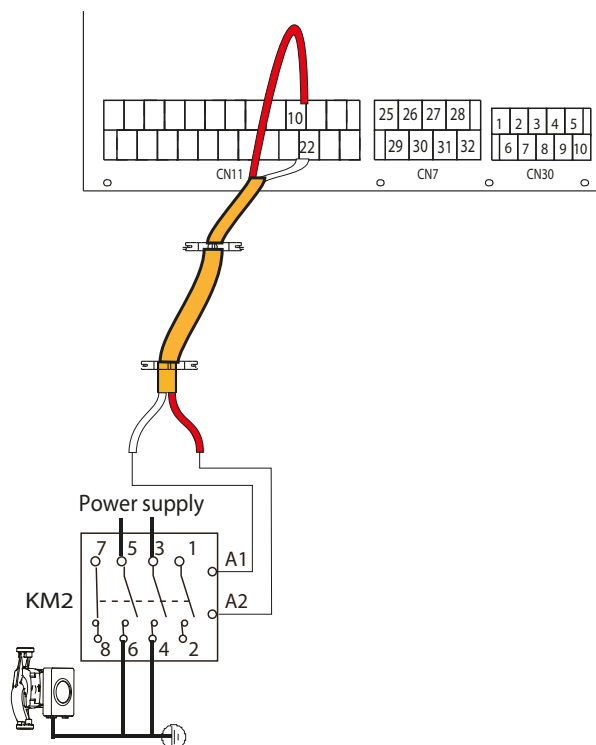

Voltage	220-240VAC
Maximum running current(A)	0.2
Wiring size(mm ²)	0.75
Control port signal type	Type 2

a) Procedure

- Connect the cable to the appropriate terminals as shown in the picture.
- Fix the cable with cable ties to the cable tie mountings to ensure stress relief

10) For smart grid:

- The unit has smart grid function, there are two ports on PCB to connect SG signal and EVU signal as following:

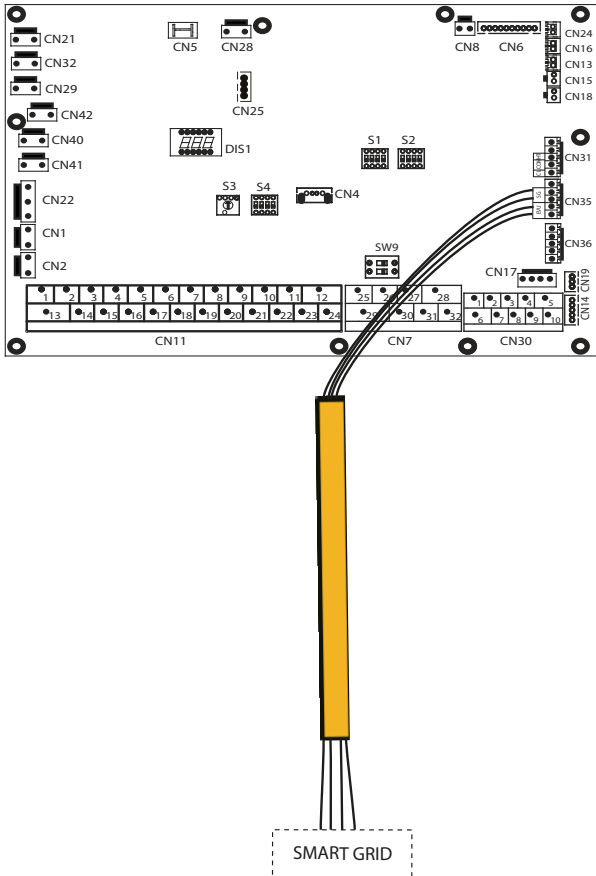

1. when EVU signal is on, the unit operate as below:
DHW mode turn on, the setting temperature will be changed to 70°C automatically, and the TBH operate as below: $T_5 < 69$. the TBH is on, $T_5 \geq 70$, the TBH is off. The unit operate in cooling/heating mode as the normal logic.
2. When EVU signal is off, and SG signal is on, the unit operate normally.
3. When EVU signal is off, SG signal is off, the DHW mode is off, and the TBH is invalid, disinfect function is invalid. The max running time for cooling/heating is "SG RUNNIN TIME", then unit will be off.

10 START-UP AND CONFIGURATION

The unit should be configured by the installer to match the installation environment (outdoor climate, installed options, etc.) and user expertise.

It is important that all information in this chapter is read sequentially by the installer and that the system is configured as applicable.

10.1 DIP switch settings overview

10.1.1 Function setting

DIP switch S1, S2 and S4 are located on the main control hydraulic module board (see "9.3.1 main control board of hydraulic module").

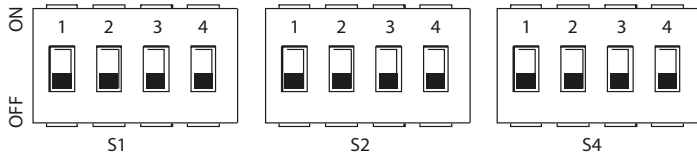

Switch off the power supply before making any changes to the DIP switch settings.

DIP switch	ON= 1	OFF=0	Factory Defaults	DIP switch	ON= 1	OFF=0	Factory Defaults	DIP switch	ON= 1	OFF=0	Factory Defaults	
S1	1/2	0/0=IBH (One-step control) 0/1=IBH (Two-step control) 1/1=IBH (Three-step control)	Refer to electrically controlled wiring diagram	S2	1	Start pump_o after six hours will be invalid	Refer to electrically controlled wiring diagram	S4	1	Master unit: clear addresses of all slave units Slave unit: clear its own address	Keep the current address	Refer to electrically controlled wiring diagram
	3/4	0/0 = without BH and AHS 1/0 = with IBH 0/1 = with AHS for heat mode 1/1 = with AHS for heat mode and DHW mode			2	without TBH			with TBH	2	Reserved	
					3/4	0/0=pump 1 0/1=pump 2 1/0=pump 3 1/1=pump 4			3/4	Reserved		

10.2 Initial start-up at low outdoor ambient temperature

During initial start-up and when water temperature is low, it is important that the water is heated gradually. Failure to do so may result in concrete floors cracking due to rapid temperature change. Please contact the responsible cast concrete building contractor for further details.

To do so, the lowest water flow set temperature can be decreased to a value between 25°C and 35°C by adjusting the FOR SERVICEMAN. Refer to 10.5.12 "SPECIAL FUNCTION" .

10.3 Pre-operation checks

Checks before initial start-up.

DANGER

Switch off the power supply before making any connections.

After the installation of the unit, check the following before switching on the circuit breaker:

- Field wiring: Make sure that the field wiring between the local supply panel and unit and valves (when applicable), unit and room thermostat (when applicable), unit and domestic hot water tank, and unit and backup heater kit have been connected according to the instructions described in the chapter 9.7 "Field wiring", according to the wiring diagrams and to local laws and regulations.
- Fuses, circuit breakers, or protection devices Check that the fuses or the locally installed protection devices are of the size and type specified in 14 "Technical specifications". Make sure that no fuses or protection devices have been bypassed.
- Backup heater circuit breaker: Do not forget to turn on the backup heater circuit breaker in the switchbox (it depends on the backup heater type). Refer to the wiring diagram.
- Booster heater circuit breaker: Do not forget to turn on the booster heater circuit breaker (applies only to units with optional domestic hot water tank installed).
- Ground wiring: Make sure that the ground wires have been connected properly and that the ground terminals are tightened.
- Internal wiring: Visually check the switch box for loose connections or damaged electrical components.

- Mounting: Check that the unit is properly mounted, to avoid abnormal noises and vibrations when starting up the unit.
- Damaged equipment: Check the inside of the unit for damaged components or squeezed pipes.
- Refrigerant leak: Check the inside of the unit for refrigerant leakage. If there is a refrigerant leak, call your local dealer.
- Power supply voltage: Check the power supply voltage on the local supply panel. The voltage must correspond to the voltage on the identification label of the unit.
- Air purge valve: Make sure the air purge valve is open (at least 2 turns).
- Shut-off valves: Make sure that the shut-off valves are fully open.

10.4 The circulation pump

The relationships between the head and the water flow rated, the PMW Return and the water flow rated are shown in the graph below.

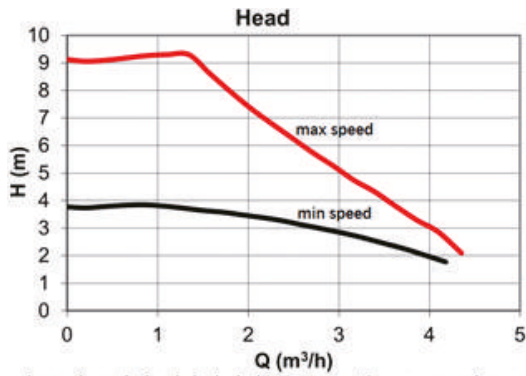

Area of regulation is included in between the max speed curve and the min speed curve.

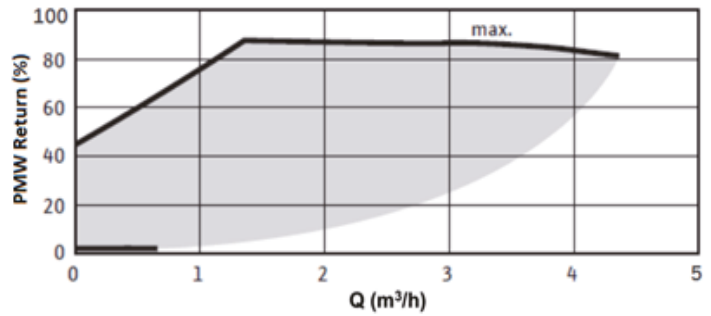

Available external static pressure VS Flow rate

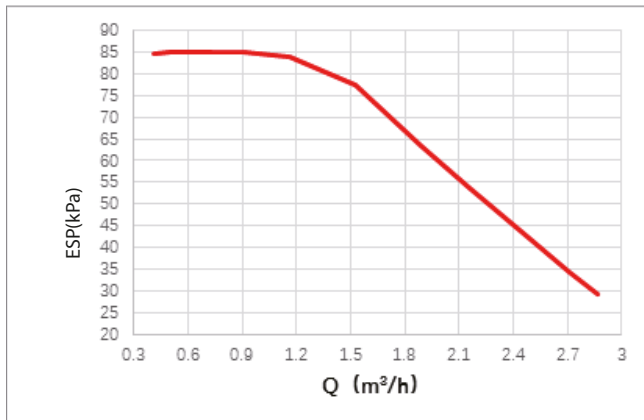

Available external static pressure VS Flow rate

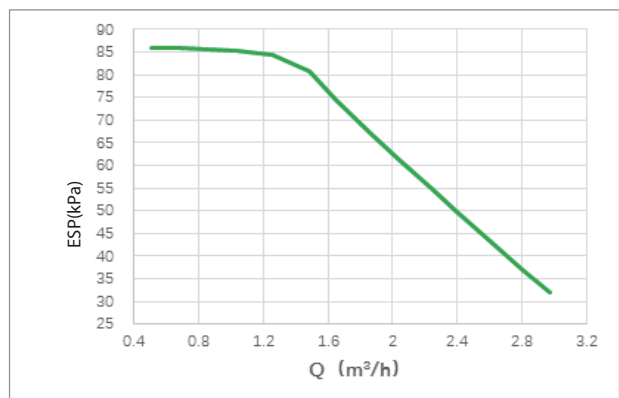

12-16kW

CAUTION

If the valves are at the incorrect position, the circulation pump will be damaged.

⚠ DANGER

If it's necessary to check the running status of the pump when unit power on, please do not touch the internal electronic control box components to avoid electric shock.

Failure diagnosis at first installation

- If nothing is displayed on the user interface, it is necessary to check for any of the following abnormalities before diagnosing possible error codes.
 - Disconnection or wiring error (between power supply and unit and between unit and user interface).
 - The fuse on the PCB may be broken.
- If the user interface shows "E8" or "E0" as an error code, there is a possibility that there is air in the system, or the water level in the system is less than the required minimum.
- If the error code E2 is displayed on the user interface, check the wiring between the user interface and unit.
- More error code and failure causes can be found in 13.4 "Error codes".

10.5 Field settings

The unit should be configured to match the installation environment (outdoor climate, installed options, etc.) and user demand. A number of field settings are available. These settings are accessible and programmable through "FOR SERVICEMAN" in user interface.

Powering on the unit

- When power on the unit, "1%~99%" is displayed on the user interface during initialization. During this process the user interface cannot be operated.

Procedure

- To change one or more field settings, proceed as follows.



NOTE

Temperature valves displayed on the wired controller (user interface) are in °C.

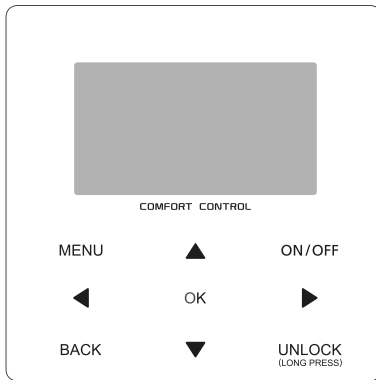

Keys	Function
MENU	■ Go to the menu structure(on the home page)
◀▶▼▲	■ Navigate the cursor on the display ■ Navigate in the menu structure ■ Adjust settings
ON/OFF	■ Turn on/off the space heating/cooling operation or DHW mode ■ Turn on/or off functions in the menu structure
BACK	■ Come back to the up level
UNLOCK	■ Long press for unlock /lock the controller ■ Unlock /lock some functions such as "DHW temperature adjusting"
ON	■ Go to the next step when programming a schedule in the menu structure; and confirm a selection to enter in the submenu of the menu structure.

About FOR SERVICEMAN

"FOR SERVICEMAN" is designed for the installer to set the parameters.

- Setting the composition of equipment.
- Setting the parameters.

How to go to FOR SERVICEMAN

Go to MENU> FOR SERVICEMAN. Press OK

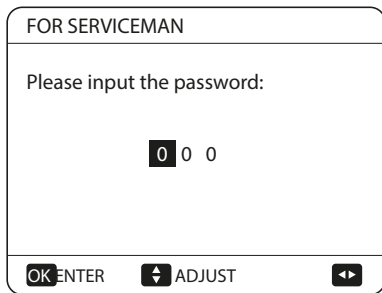

Press ◀▶ to navigate and press ▼▲ to adjust the numerical valve. Press OK. The password is 234, the following pages will be displayed after putting the password:

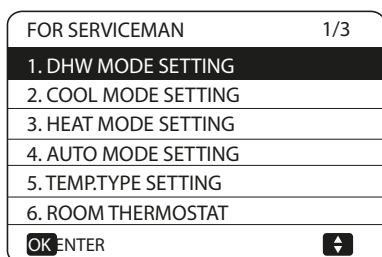

FOR SERVICEMAN	2/3
7. OTHER HEATING SOURCE	
8. HOLIDAY AWAY MODE SET	
9. SERVICE CALL SETTING	
10. RESTORE FACTORY SETTINGS	
11. TEST RUN	
12. SPECIAL FUNCTION	
OK ENTER	↔

FOR SERVICEMAN	3/3
13. AUTO RESTART	
14. POWER INPUT LIMITATION	
15. INPUT DEFINE	
16. CASCADE SET	
17. HMI ADDRESS SET	
OK ENTER	↔

Press ▼ ▲ to scroll and use "OK" to enter submenu.

10.5.1 DHW MODE SETTING

DHW = domestic hot water

Go to MENU> FOR SERVICEMAN> 1.DHW MODE SETTING.

Press OK. The following pages will be displayed:

1 DHW MODE SETTING	1/5
1.1 DHW MODE	YES
1.2 DISINFECT	YES
1.3 DHW PRIORITY	YES
1.4 DHW PUMP	YES
1.5 DHW PRIORITY TIME SET	NON
ADJUST	↔

1 DHW MODE SETTING	2/5
1.6 dT5_ON	5 °C
1.7 dT1S5	10°C
1.8 T4DHWMAX	43°C
1.9 T4DHWMIN	-10°C
1.10 t_INTERVAL_DHW	5 MIN
ADJUST	↔

1 DHW MODE SETTING	3/5
1.11 dT5_TBH_OFF	5 °C
1.12 T4_TBH_ON	5 °C
1.13 t_TBH_DELAY	30 MIN
1.14 T5S_DI	65°C
1.15 t_DI HIGHTEMP.	15MIN
ADJUST	↔

1 DHW MODE SETTING	4/5
1.16 t_DI_MAX	210 MIN
1.17 t_DHWHP_RESTRICT	30 MIN
1.18 t_DHWHP_MAX	120 MIN
1.19 DHWPUMP TIME RUN	YES
1.20 PUMP RUNNING TIME	5 MIN
ADJUST	↔

1 DHW MODE SETTING	5/5
1.21 DHW PUMP DI RUN	NON
ADJUST	↔

10.5.2 COOL MODE SETTING

Go to MENU> FOR SERVICEMAN> 2.COOL MODE SETTING. Press OK.

The following pages will be displayed:

2 COOL MODE SETTING	1/3
2.1 COOL MODE	YES
2.2 t_T4_FRESH_C	2.0HRS
2.3 T4C MAX	43°C
2.4 T4C MIN	20°C
2.5 dT1SC	5°C
ADJUST	↔

2 COOL MODE SETTING	2/3
2.6 dTSC	2 °C
2.7 t_INTERVAL_C	5MIN
2.8 T1SetC1	10°C
2.9 T1SetC2	16°C
2.10 T4C1	35°C
ADJUST	↔

2 COOL MODE SETTING	3/3
2.11 T4C2	25 °C
2.12 ZONE1 C-EMISSION	FCU
2.13 ZONE2 C-EMISSION	FLH
ADJUST	↔

10.5.3 HEAT MODE SETTING

Go to MENU>FOR SERVICEMAN> 3.HEAT MODE SETTING.

Press OK. The following pages will be displayed:

3 HEAT MODE SETTING	1/3
3.1 HEAT MODE	YES
3.2 t_T4_FRESH_H	2.0HRS
3.3 T4HMAX	16°C
3.4 T4HMIN	-15°C
3.5 dT1SH	5°C
ADJUST	↔

3 HEAT MODE SETTING	2/3
3.6 dTSH	2 °C
3.7 t_INTERVAL_H	5MIN
3.8 T1SetH1	35°C
3.9 T1SetH2	28°C
3.10 T4H1	-5°C
ADJUST	↔

3 HEAT MODE SETTING	3/3
3.11 T4H2	7 °C
3.12 ZONE1 H-EMISSION	RAD.
3.13 ZONE2 H-EMISSION	FLH
3.14 t_DELAY_PUMP	2MIN
ADJUST	↔

10.5.4 AUTO MODE SETTING

Go to MENU> FOR SERVICEMAN> 4.AUTO MODE SETTING.

Press OK, the following page will be displayed.

4 AUTO. MODE SETTING	
4.1 T4AUTOCMIN	25°C
4.2 T4AUTOHMAX	17°C
ADJUST	↔

10.5.8 HOLIDAY AWAY SETTING

The HOLIDAY AWAY SETTING is used to set the outlet water temperature to prevent freezing when away for holiday.

Go to MENU> FOR SERVICEMAN> 8.HOLIDAY AWAY SETTING. Press OK. The following page will be displayed:

8 HOLIDAY AWAY SETTING	
8.1 T1S_H.A._H	20°C
8.2 T5S_H.A._DHW	20°C
ADJUST	

10.5.9 SERVICE CALL SETTING

The installers can set the phone number of the local dealer in 9.SERVICE CALL SETTING. If the unit doesn't work properly, call this number for help.

Go to MENU> FOR SERVICEMAN>SERVICE CALL. Press OK. The following page will be displayed:

9 SERVICE CALL SETTING	
PHONE NO. *****	
MOBILE NO. *****	
CONFIRM	ADJUST

Press ▼ ▲ to scroll and set the phone number. The maximum length of the phone number is 13 digits, if the length of phone number is short than 12, please input ■, as shown below:

9 SERVICE CALL	
PHONE NO. *****	■■■
MOBILE NO. *****	■
CONFIRM	ADJUST

The number displayed on the user interface is the phone number of your local dealer.

10.5.10 RESTORE FACTORY SETTINGS

The RESTORE FACTORY SETTING is used to restore all the parameters set in the user interface to the factory setting.

Go to MENU> FOR SERVICEMAN> 10.RESTORE FACTORY SETTINGS. Press OK. The following page will be displayed:

10 RESTORE FACTORY SETTINGS	
All the settings will come back to factory default.	
Do you want to restore factory settings?	
NO	YES
CONFIRM	

Press ◀ ▶ to scroll the cursor to YES and press OK. The following page will be displayed:

10 RESTORE FACTORY SETTINGS	
Please wait...	
5%	

After a few seconds, all the parameters set in the user interface will be restored to factory settings.

10.5.11 TEST RUN

TEST RUN is used to check correct operation of the valves, air purge, circulation pump operation, cooling, heating and domestic water heating.

Go to MENU> FOR SERVICEMAN> 11.TEST RUN. Press OK. The following page will be displayed:

11 TEST RUN	
Active the settings and active the "TEST RUN"?	
NO	YES
CONFIRM	

If YES is selected, the following pages will be displayed

11 TEST RUN	
11.1 POINT CHECK	
11.2 AIR PURGE	
11.3 CIRCULATED PUMP RUNNING	
11.4 COOL MODE RUNNING	
11.5 HEAT MODE RUNNING	
ENTER	

11 TEST RUN	
11.6 DHW MODE RUNNING	
ENTER	

If POINT CHECK is selected, the following pages will be displayed:

11 TEST RUN		1/2
3-WAY VALVE 1		OFF
3-WAY VALVE 2		OFF
PUMP I		OFF
PUMP O		OFF
PUMP C		OFF
ON/OFF		ON/OFF

11 TEST RUN		2/2
PUMPSOLAR		OFF
PUMPDHW		OFF
INNER BACKUP HEATER		OFF
TANK HEATER		OFF
3-WAY VALVE 3		OFF
ON/OFF		ON/OFF

Press ▼ ▲ to scroll to the components you want to check and press

ON/OFF. For example, when 3-way valve is selected and ON/OFF is pressed, if the 3-way valve is open/close, then the operation of 3-way valve is normal, and so are other components.

⚠ CAUTION

Before the point check, make sure the tank and the water system is filled with water, and air is expelled, or it may cause the pump or backup heater burn out.

If you select AIR PURGE and OK is pressed, the following page will be displayed :

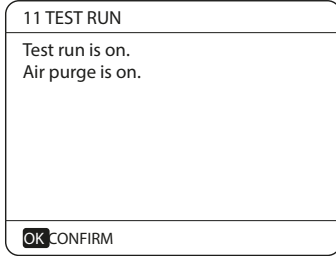

When in air purge mode, SV1 will open, SV2 will close. 60s later the pump in the unit (PUMP I) will operate for 10min during which the flow switch will not work. After the pump stops, the SV1 will close and the SV2 will open. 60s later both the PUMP I and PUMP O will operate until the next command is received.

When CIRCULATION PUMP RUNNING is selected, the following page will be displayed:

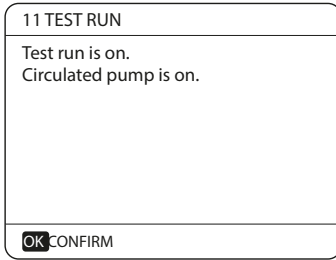

circulation pump running is turned on, all running components will stop. 60 seconds later, the SV1 will open, the SV2 will close, 60 seconds later PUMP I will operate. 30s later, if the flow switch checked normal flow, PUMP I will operate for 3min, after the pump stops 60 seconds, the SV1 will close and the SV2 will open. 60s later the both PUMP I and PUMP O will operate, 2 mins later, the flow switch will check the water flow. If the flow switch closes for 15s, PUMP I and PUMP O will operate until the next command is received.

When the COOL MODE RUNNING is selected, the following page will be displayed:

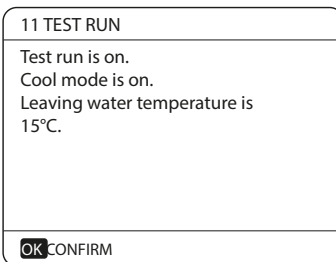

During cool MODE test running, the default target outlet water temperature is 7°C. The unit will operate until the water temperature drops to a certain valve or the next command is received.

When the HEAT MODE RUNNING is selected, the following page will be displayed:

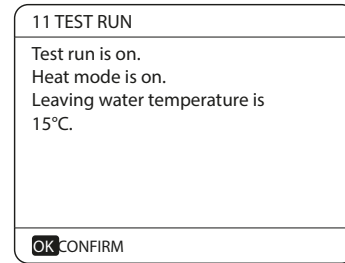

During HEAT MODE test running, the default target outlet water temperature is 35°C. The IBH (internal backup heater) will turn on after the compressor runs for 10 min. After the IBH runs for 3 minutes, the IBH will turn off, the heat pump will operate until the water temperature increase to a certain valve or the next command is received.

When the DHW MODE RUNNING is selected, the following page will be displayed:

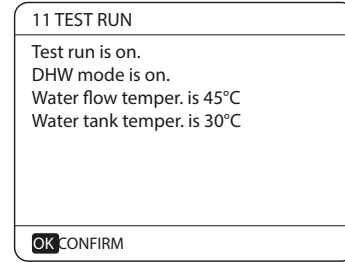

During DHW MODE test running, the default target temperature of the domestic water is 55°C. The TBH (tank boost heater) will turn on after the compressor runs for 10min. The TBH will turn off 3 minutes later, the heat pump will operate until the water temperature increase to a certain valve or the next command is received.

During test run, all buttons except OK are invalid. If you want to turn off the test run, please press OK. For example ,when the unit is in air purge mode after you press OK, the following page will be displayed:

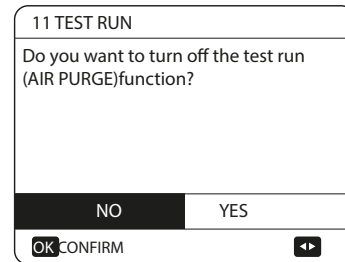

Press ◀▶ to scroll cursor to yes and press ok. The test run will turn off.

10.5.12 SPECIAL FUNCTION

When it is in special function modes, the wired controller can not operate, the page do not return to the homepage, and the screen showed the page that special function runs, the wired controller do not locked.

💡 NOTE

During special function operating other functions (WEEKLY SCHEDULE/TIMER , HOLIDAY AWAY, HOLIDAY HOME) can't be used.

Go to MENU> FOR SERVICEMAN> 12.SPECIAL FUNCTION. Before floor heating, if a large amount of water remains on the floor, the floor may be warped or even rupture during floor heating operation, in order to protect the floor, floor drying is necessary, during which the temperature of the floor should be increased gradually.

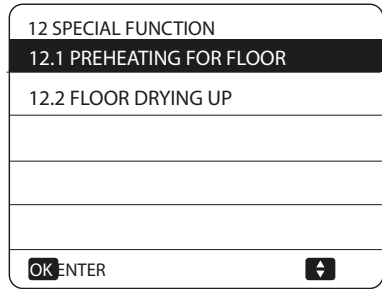
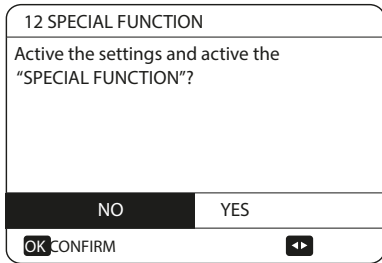

Press ▼ ▲ to scroll and press OK to enter.
 During first operation of the unit, air may remain in the water system which can cause malfunctions during operation. It is necessary to run the air purge function to release the air (make sure the air purge valve is open).
 If PREHEATING FOR FLOOR is selected, after press OK, the following page will be displayed:

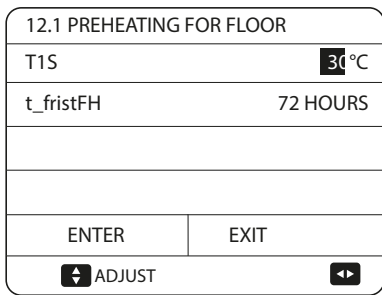

When the cursor is on OPERATE PREHEATING FOR FLOOR, Use ◀▶ to scroll to YES and press OK. The following page will be displayed:

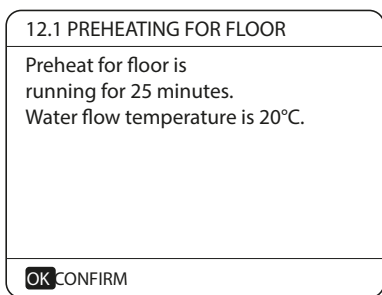

During preheating for floor, all the buttons except OK are invalid. If you want to turn off the preheating for floor, please press OK. The following page will be displayed:

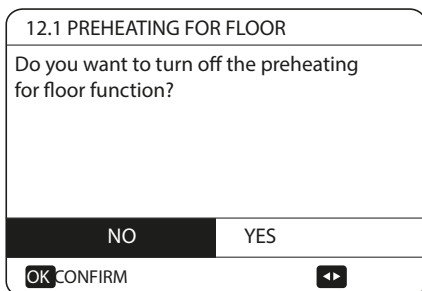

Use ◀▶ to scroll the cursor to YES and press OK, the preheating for floor will turn off.

The operation of the unit during preheating for floor described in the picture below:

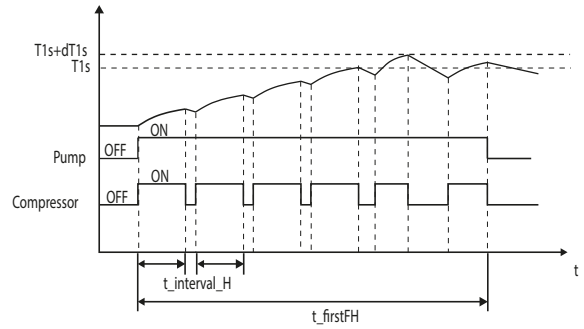

If FLOOR DRYING UP is selected, after press OK, the following pages will be displayed:

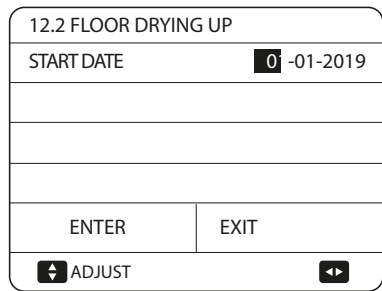
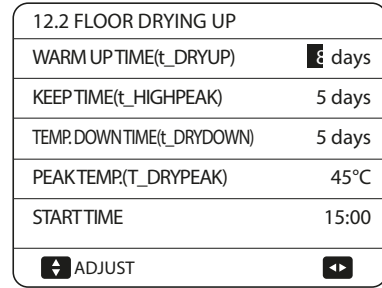

During floor drying, all the buttons except OK are invalid. When the heat pump malfunctions, the floor drying mode will turn off when the backup heater and additional heating source is unavailable. If you want to turn off floor drying up, please press OK. The following page will be displayed

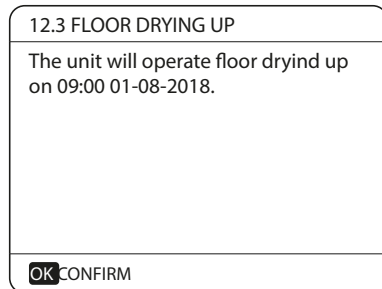

Use ◀▶ to scroll the cursor to YES and press OK. Floor drying will turn off. The target outlet water temperature during floor drying up described in the picture below:

10.5.18 SETTING PARAMETERS

The parameters related to this chapter are shown in the table below.

Order number	Code	State	Default	Minimum	Maximum	Setting interval	Unit
1.1	DHW MODE	Enable or disable the DHW mode:0=NON,1=YES	1	0	1	1	/
1.2	DISINFECT	Enable or disable the disinfect mode:0=NON,1=YES	1	0	1	1	/
1.3	DHW PRIORITY	Enable or disable the DHW priority mode:0=NON,1=YES	1	0	1	1	/
1.4	DHW PUMP	Enable or disable the DHW pump mode:0=NON,1=YES	0	0	1	1	/
1.5	DHW PRIORITY TIME SET	Enable or disable the DHW priority time set:0=NON,1=YES	0	0	1	1	/
1.6	dT5_ON	The temperature difference for starting the heat pump	10	1	30	1	°C
1.7	dT1S5	The correct valve to adjust the output of the compressor.	10	5	40	1	°C
1.8	T4DHWMAX	The maximum ambient temperature that the heat pump can operate at for domestic water heating	43	35	43	1	°C
1.9	T4DHWMIN	The minimum ambient temperature that the heat pump can operate for domestic water heating	-10	-25	5	1	°C
1.10	t_INTERVAL_DHW	The start time interval of the compressor in DHW mode	5	5	5	1	min
1.11	dT5_TBH_OFF	The temperature difference between T5 and T5S that turns the booster heater off.	5	0	10	1	°C
1.12	T4_TBH_ON	The highest outdoor temperature the TBH can operate.	5	-5	20	1	°C
1.13	t_TBH_DELAY	The time that the compressor has run before starting the booster heater	30	0	240	5	min
1.14	T5S_DI	The target temperature of water in the domestic hot water tank in the DISINFECT function.	65	60	70	1	°C
1.15	t_DI_HIGHTEMP.	The time that the highest temperature of water in the domestic hot water tank in the DISINFECT function will last	15	5	60	5	min
1.16	t_DI_MAX	The maximum time that disinfection will last	210	90	300	5	min
1.17	t_DHWHP_RESTRICT	The operation time for the space heating/cooling operation.	30	10	600	5	min
1.18	t_DHWHP_MAX	The maximum continuous working period of the heat pump in DHW PRIORITY mode	90	10	600	5	min
1.19	DHW PUMP TIME RUN	Enable or disable the DHW pump run as timed and keeps running for PUMP RUNNING TIME:0=NON,1=YES	1	0	1	1	/
1.20	PUMP RUNNING TIME	the certain time that the DHW pump will keep running for	5	5	120	1	min
1.21	DHW PUMP DISINFECT	Enable or disable the DHW pump operate when the unit is in disinfect mode and T5≥T5S_DI-2:0=NON,1=YES	1	0	1	1	/
2.1	COOL MODE	Enable or disable the cooling mode:0=NON,1=YES	1	0	1	1	/
2.2	t_T4_FRESH_C	The refresh time of climate related curves for cooling mode	0,5	0,5	6	0,5	hours
2.3	T4CMAX	The highest ambient operation temperature for cooling mode	52	35	52	1	°C
2.4	T4CMIN	The lowest ambient operating temperature for cooling mode	10	-5	25	1	°C
2.5	dT1SC	The temperature difference for starting the heat pump (T1)	5	2	10	1	°C
2.6	dTSC	The temperature difference for starting the heat pump (Ta)	2	1	10	1	°C
2.7	t_INTERVAL_COOL	The start time interval of the compressor in COOL mode	5	5	5	1	°C
2.8	T1SetC1	The setting temperature 1 of climate related curves for cooling mode	10	5	25	1	min
2.9	T1SetC2	The setting temperature 2 of climate related curves for cooling mode	16	5	25	1	°C
2.10	T4C1	The ambient temperature 1 of climate related curves for cooling mode	35	-5	46	1	°C
2.11	T4C2	The ambient temperature 2 of climate related curves for cooling mode	25	-5	46	1	°C
2.12	ZONE1 C-EMISSION	The type of zone1 end for cooling mode 0=FCU(fan coil unit) 1=RAD. (radiator) 2=FLH (floor heating)	0	0	2	1	/
2.13	ZONE2 C-EMISSION	The type of zone2 end for cooling mode 0=FCU(fan coil unit) 1=RAD. (radiator) 2=FLH (floor heating)	0	0	2	1	/
3.1	HEAT MODE	Enable or disable the heating mode	1	0	1	1	/
3.2	t_T4_FRESH_H	The refresh time of climate related curves for heating mode	0,5	0,5	6	0,5	hours
3.3	T4HMAX	The maximum ambient operating temperature for heating mode	25	20	35	1	°C
3.4	T4HMIN	The minimum ambient operating temperature for heating mode	-15	-25	15	1	°C
3.5	dT1SH	The temperature difference for starting the unit (T1)	5	2	10	1	°C
3.6	dTSH	The temperature difference for starting the unit (Ta)	2	1	10	1	°C
3.7	t_INTERVAL_HEAT	The start time interval of the compressor in HEAT mode	5	5	5	1	min
3.8	T1SetH1	The setting temperature 1 of climate related curves for heating mode	35	25	60	1	°C
3.9	T1SetH2	The setting temperature 2 of climate related curves for heating mode	28	25	60	1	°C
3.10	T4H1	The ambient temperature 1 of climate related curves for heating mode	-5	-25	35	1	°C
3.11	T4H2	The ambient temperature 2 of climate related curves for heating mode	7	-25	35	1	°C
3.12	ZONE1 H-EMISSION	The type of zone1 end for heating mode 0=FCU(fan coil unit) 1=RAD. (radiator) 2=FLH (floor heating)	1	0	2	1	/
3.13	ZONE2 H-EMISSION	The type of zone2 end for heating mode 0=FCU(fan coil unit) 1=RAD. (radiator) 2=FLH (floor heating)	2	0	2	1	/
3.14	t_DELAY_PUMP	The time that the compressor has run before starting the pump.	2	2	20	0,5	min
4.1	T4AUTOCMIN	The minimum operating ambient temperature for cooling in auto mode	25	20	29	1	°C
4.2	T4AUTOHMAX	The maximum operating ambient temperature for heating in auto mode	17	10	17	1	°C

5.1	WATER FLOW TEMP.	Enable or disable the WATER FLOW TEMP.:0=NON,1=YES	1	0	1	1	/
5.2	ROOM TEMP.	Enable or disable the ROOM TEMP.:0=NON,1=YES	0	0	1	1	/
5.3	DOUBLE ZONE	Enable or disable the ROOM THERMOSTAT DOUBLE ZONE:0=NON,1=YES	0	0	1	1	7
6.1	ROOM THERMOSTAT	The style of room thermostat 0=NON; 1=MODE SET; 2=ONE ZONE; 3=DOUBLE ZONE	0	0	3	1	/
7.1	dT1_IBH_ON	The temperature difference between T1S and T1 for starting the backup heater	5	2	10	1	°C
7.2	t_IBH_DELAY	The time that the compressor has run before the first backup heater turns on	30	15	120	5	min
7.3	T4_IBH_ON	The ambient temperature for starting the backup heater	-5	-15	10	1	°C
7.4	dT1_AHS_ON	The temperature difference between T1S and T1B for turning the additional heating source on	5	2	10	1	°C
7.5	t_AHS_DELAY	The time that the compressor has run before starting the additional heating source	30	5	120	5	min
7.6	T4_AHS_ON	The ambient temperature for starting the additional heating source	-5	-15	10	1	°C
7.7	IBH_LOCATE	IBH/AHS installation location PIPE LOOP=0; BUFFER TANK=1	0	0	0	0	°C
7.8	P_IBH1	Power input of IBH1	0	0	20	0.5	kW
7.9	P_IBH2	Power input of IBH2	0	0	20	0.5	kW
7.10	P_TBH	Power input of TBH	2	0	20	0.5	kW
8.1	T1S_HA_H	The target outlet water temperature for space heating when in holiday away mode	25	20	25	1	°C
8.2	T5S_HA_DHW	The target outlet water temperature for domestic hot water heating when in holiday away mode	25	20	25	1	°C
12.1	PREHEATING FOR FLOOR T1S t_FIRSTFH	The setting temperature of outlet water during first preheating for floor	25	25	35	1	°C
12.3	t_FIRST-H	The time last for preheating floor	72	48	96	12	hour
12.4	t_DRYUP	The day for warming up during floor drying up	8	4	15	1	day
12.5	t_HIGHPEAK	The continue days in high temperature during floor drying up	5	3	7	1	day
12.6	t_DRYD	The day of dropping temperature during floor drying up	5	4	15	1	day
12.7	T_DRYPEAK	The target peak temperature of water flow during floor drying up	45	30	55	1	°C
12.8	START TIME	The start time of floor drying up	Hour: the present time (not on the hour +1, on the hour +2) Minute 00	0:00	23:30	1/30	h/min
12.9	START DATE	The start date of floor drying up	the present date	1/1/2000	31/12/2099	1/1/2001	d/m/y
13.1	AUTO RESTART COOL/HEAT MODE	Enable or disable the auto restart cooling/heating mode. 0=NON,1=YES	1	0	1	1	/
13.2	AUTO RESTART DHW MODE	Enable or disable the auto restart DHW mode. 0=NON,1=YES	1	0	1	1	/
14.1	POWER INPUT LIMITATION	The type of power input limitation, 0=NON, 1~8=TYPE 1~8	0	0	8	1	/
15.1	ON/OFFM1 M2	Define the function of the M1M2 switch; 0= REMOTE ON/OFF,1= TBH ON/OFF, 2= AHS ON/OFF	0	0	2	1	/
15.2	SMART GRID	Enable or disable the SMART GRID; 0=NON,1=YES	0	0	1	1	/
15.3	T1b (Tw2)	Enable or disable the T1b(Tw 2) ; 0=NON,1=YES	0	0	1	1	/
15.4	Tbt1	Enable or disable the Tbt1; 0=NON,1=YES	0	0	1	1	/
15.5	Tbt2	Enable or disable the Tbt2; 0=NON,1=YES	0	0	1	1	/
15.6	Ta	Enable or disable the Ta; 0=NON,1=YES	0	0	1	1	/
15.7	SOLAR INPUT	Choose the SOLAR INPUT; 0=NON, 1=CN18Tsolar, 2=CN11SL1SL2	0	0	2	1	/
15.8	F-PIPE LENGTH	Choose the total length of the liquid pipe (F-PIPE LENGTH); 0=F-PIPE LENGTH <10m,1=F-PIPE LENGTH ≥ 10m	0	0	1	1	/
15.9	dTbt2	The temperature difference for starting the unit (Tbt2)	15	0	50	1	°C
15.10	RT/Ta_PCB	Enable or disable the RT/Ta_PCB; 0=NON,1=YES	0	0	1	1	/
16.1	PER_START	Start-up percentage of multiple units	10	10	100	10	%
16.2	TIME_ADJUST	Adjustment time of adding and subtracting units	5	1	60	1	min
16.3	ADDRESS RESET	Reset the address code of the unit	FF	0	15	1	/
17.1	HMI SET	Choose the HMI; 0=MASTER,1=SLAVE	0	0	1	1	/
17.2	HMI ADDRESS FOR BMS	Set the HMI address code for BMS	1	1	16	1	/

11 TEST RUN AND FINAL CHECKS

The installer is obliged to verify correct operation of unit after installation.

11.1 Final checks

Before switching on the unit, read following recommendations: When the complete installation and all necessary settings have been carried out, close all front panels of the unit and refit the unit cover. The service panel of the switch box may only be opened by a licensed electrician for maintenance purposes.

That during the first running period of the unit, required power input may be higher than stated on the nameplate of the unit. This phenomenon originates from the compressor that needs elapse of a 50 hours run in period before reaching smooth operation and stable power consumption.

NOTE

That during the first running period of the unit, required power input may be higher than stated on the nameplate of the unit. This phenomenon originates from the compressor that needs elapse of a 50 hours run in period before reaching smooth operation and stable power consumption.

11.2 Test run operation (manually)

If required, the installer can perform a manual test run operation at any time to check correct operation of air purge, heating, cooling and domestic water heating, refer to 10.5.11 "Test run".

12 MAINTENANCE AND SERVICE

In order to ensure optimal availability of the unit, a number of checks and inspections on the unit and the eld wiring have to be carried out at regular intervals.

This maintenance needs to be carried out by your local technician.

DANGER

ELECTRIC SHOCK

- Before carrying out any maintenance or repairing activity, must switch off the power supply on the supply panel.
- Do not touch any live part for 10 minutes after the power supply is turned off.
- The crank heater of compressor may operate even in standby.
- Please note that some sections of the electric component box are hot.
- Forbid touch any conductive parts.
- Forbid rinse the unit. It may cause electric shock or fire.
- Forbid leave the unit unattended when service panel is removed.

The following checks must be performed at least once a year by qualified person

- Water pressure
Check the water pressure, if it is below ! bat fill water to the system.
- Water filter
Clean the water filter
- Water pressure relief valve
Check for correct operation of the pressure relief valve by turning the black knob on the valve counter-clockwise:
 - If you do not hear a clacking sound, contact your local dealer.
 - In case the water keeps running out of the unit, close both the

water inlet and outlet shut-o valves first and then contact your local dealer.

- Pressure relief valve hose
- Check that the pressure relief valve hose is positioned appropriately to drain the water.
- Backup heater (if present) vessel insulation cover
- Check that the backup heater insulation cover is fastened tightly around the backup heater vessel.
- Domestic hot water tank pressure relief valve (eld supply) Applies only to installations with a domestic hot water tank.
- Check for correct operation of the pressure relief valve on the domestic hot water tank.
- Domestic hot water tank booster heater
- Applies only to installations with a domestic hot water tank. It is advisable to remove lime buildup on the booster heater to extend its life span, especially in
 - regions with hard water. To do so, drain the domestic hot water tank, remove the booster heater from the domestic hot water tank and immerse in a bucket (or similar) with lime-removing product for 24 hours.
- Unit switch box
 - Carry out a thorough visual inspection of the switch box and look for obvious defects such as loose connections or defective wiring.
 - Check for correct operation of contactors with an ohm meter. All contacts of these contactors must be in open position.
- Use of glycol (Refer to 9.4.4 "Water circuit anti-freeze protection") Document the glycol concentration and the pH-value in the system at least once a year.
 - A PH-value below 8.0 indicates that a significant portion of the inhibitor has been depleted and that more inhibitor needs to be added.
 - When the PH-value is below 7.0 then oxidation of the glycol occurred, the system should be drained and flushed thoroughly before severe damage occurs.

Make sure that the disposal of the glycol solution is done in accordance with relevant local laws and regulations.

13 TROUBLE SHOOTING

This section provides useful information for diagnosing and correcting certain troubles which may occur in the unit.

This troubleshooting and related corrective actions may only be carried out by your local technician.

13.1 General guidelines

Before starting the troubleshooting procedure, carry out a thorough visual inspection of the unit and look for obvious defects such as loose connections or defective wiring.

WARNING

When carrying out an inspection on the switch box of the unit, always make sure that the main switch of the unit is switched off.

When a safety device was activated, stop the unit and find out why the safety device was activated before resetting it. Under no circumstances can safety devices be bridged or changed to a valve other than the factory setting. If the cause of the problem cannot be found, call your local dealer.

If the pressure relief valve is not working correctly and is to be replaced, always reconnect the exible hose attached to the pressure relief valve to avoid water dripping out of the unit!

NOTE

For problems related to the optional solar kit for domestic water heating, refer to the troubleshooting in the Installation and owner's manual for that kit.

13.2 General symptoms

Symptom 1: The unit is turned on but the unit is not heating or cooling as expected

POSSIBLE CAUSES	CORRECTIVE ACTION
The temperature setting is not correct	Check the parameters.T4HMAX,T4HMIN in heat mode. T4CMAX,T4CMIN in cool mode.T4DHWMAX,T4DHWMIN in DHW mode.
The water flow is too low.	<ul style="list-style-type: none"> • Check that all shut off valves of the water circuit are in the right position. • Check if the water filter is plugged. • Make sure there is no air in the water system. • Check the water pressure. The water pressure must be >1 bar (water is cold). • Make sure that the expansion vessel is not broken. • Check that the resistance in the water circuit is not too high for the pump.
The water volume in the installation is too low.	Make sure that the water volume in the installation is above the minimum required valve (refer to "9.4.2 Water volume and sizing expansion vessels").

Symptom 2: The unit is turned on but the compressor is not starting (space heating or domestic water heating)

POSSIBLE CAUSES	CORRECTIVE ACTION
The unit maybe operate out of its operation range (the water temperature is too low).	<p>In case of low water temperature, the system utilizes the backup heater (if present) to reach the minimum water temperature first (12°C).</p> <ul style="list-style-type: none"> • Check that the backup heater power supply is correct. • Check that the backup heater thermal fuse is closed. • Check that the backup heater thermal protector is not activated. • Check that the backup heater contactors are not broken.

Symptom 3: Pump is making noise (cavitation)

POSSIBLE CAUSES	CORRECTIVE ACTION
There is air in the system.	Purge air.
Water pressure at pump inlet is too low.	<ul style="list-style-type: none"> • Check the water pressure. The water pressure must be > 1 bar (water is cold). • Check that the expansion vessel is not broken. • Check that the setting of the pre- pressure of the expansion vessel is correct (refer to "9.4.2 Water volume and sizing expansion vessels").

Symptom 4: The water pressure relief valve opens

POSSIBLE CAUSES	CORRECTIVE ACTION
The expansion vessel is broken.	Replace the expansion vessel
The filling water pressure in the installation is higher than 0.3MPa.	Make sure that the filling water pressure in the installation is about 0.10~0.20MPa (refer to "9.4.2 Water volume and sizing expansion vessels").

Symptom 5: The water pressure relief valve leaks

POSSIBLE CAUSES	CORRECTIVE ACTION
Dirt is blocking the water pressure relief valve outlet.	<p>Check for correct operation of the pressure relief valve by turning the red knob on the valve counter clockwise:</p> <ul style="list-style-type: none"> • If you do not hear a clacking sound, contact your local dealer. • In case the water keeps running out of the unit, close both the water inlet and outlet shut-off valves first and then contact your local dealer.

Symptom 6: Space heating capacity shortage at low outdoor temperatures

POSSIBLE CAUSES	CORRECTIVE ACTION
Backup heater operation is not activated.	Check that the "OTHER HEATING SOURCE/ BACKUP HEATER" is enabled, see "10.5 Field settings" Check whether or not the thermal protector of the backup heater has been activated (refer to "Controls parts for backup heater (IBH)"). Check if booster heater is running, the backup heater and booster heater can't operate simultaneously.
Too much heat pump capacity is used for heating domestic hot water (applies only to installations with a domestic hot water tank).	Check that the "t_DHWHP_MAX" and "t_DHWHP_RESTRICT" are configured appropriately: <ul style="list-style-type: none"> • Make sure that the "DHW PRIORITY" in the user interface is disabled. • Enable the "T4_TBH_ON" in the user interface/FOR SERVICEMAN to activate the booster heater for domestic water heating.

Symptom 7: Heat mode can't change to DHW mode immediately

POSSIBLE CAUSES	CORRECTIVE ACTION
Volume of tank is too small and the location of water temperature probe not high enough	<ul style="list-style-type: none"> • Set "dT1S5" to maximum valve, and set "t_DHWHP_RESTRICT" to minimum valve. • Set dT1SH to 2°C. • Enable TBH, and TBH should be controlled by the outdoor unit. • If AHS is available, turn on first, if requirement for turn heat pump on is fulfilled, the heat pump will turn on. • If both TBH and AHS are not available, try to change the position of T5 probe (refer to 2 "General introduction").

Symptom 8: DHW mode can't change to Heat mode immediately

POSSIBLE CAUSES	CORRECTIVE ACTION
Heat exchanger for space heating not big enough	<ul style="list-style-type: none"> • Set "t_DHWHP_MAX" to minimum valve, the suggested valve is 60min. • If circulating pump out of unit is not controlled by unit, try to connect it to the unit. • Add 3-way valve at the inlet of fan coil to ensure enough water flow
Space heating load is small	Normal, no need for heating
Disinfect function is enabled but without TBH	<ul style="list-style-type: none"> • Disable disinfect function • add TBH or AHS for DHW mode
Manual turn on the FAST WATER function, after the hot water meets the requirements, the heat pump fails to switch to the air-conditioning mode in time when the air conditioner is in demand	Manual turn off the FAST WATER function
When the ambient temperature is low, the hot water is not enough and the AHS is not operated or operated late	<ul style="list-style-type: none"> • Set "T4DHWMIN", the suggested valve is ≥ -5 • Set "T4_TBH_ON", the suggested valve is ≥ 5
DHW mode priority	If there is AHS or IBH connect to the unit, when the outdoor unit failed, the hydraulic module board must run DHW mode till the water temperature reach the setting temperature before change to heating mode.

Symptom 9: DHW mode heat pump stop work but setpoint not reached, space heating require heat but unit stay in DHW mode

POSSIBLE CAUSES	CORRECTIVE ACTION
Surface of coil in the tank not large enough	The same solution for Symptom 7
TBH or AHS not available	Heat pump will stay in DHW mode until "t_DHWHP_MAX" reached or setpoint is reached. Add TBH or AHS for DHW mode, TBH and AHS should be controlled by the unit.

13.3 Operation parameters

This menu is for installer or service engineer reviewing the operation parameters.

At home page, go to "MENU">"OPERATION PARAMETER".

Press "OK". There are nine pages for the operating parameter as following. Press "▼", "▲" to scroll.

Press"▶" and "◀" to check slave units' operation parameter in cascade system. The address code in the upper right corner 00 will change from "#00" to "#01", "#02" etc. accordingly

OPERATION PARAMETER		#00
ONLINE UNITS NUMBER	1	
OPERATE MODE	COOL	
SV1 STATE	ON	
SV2 STATE	OFF	
SV3 STATE	OFF	
PUMP_I	ON	
◀ ADDRESS	1/9	▶

OPERATION PARAMETER		#00
PUMP-O	OFF	
PUMP-C	OFF	
PUMP-S	OFF	
PUMP-D	OFF	
PIPE BACKUP HEATER	OFF	
TANK BACKUP HEATER	ON	
◀ ADDRESS	2/9	▶

OPERATION PARAMETER		#00
GAS BOILER	OFF	
T1 LEAVING WATER TEMP.	35°C	
WATER FLOW	1.72m³/h	
HEAT PUMP CAPACTIY	11.52kW	
POWER CONSUM.	1000kWh	
Ta ROOM TEMP	25°C	
◀ ADDRESS	3/9	▶

OPERATION PARAMETER		#00
T5 WATER TANK TEMP.	53°C	
Tw2 CIRCUIT2 WATER TEMP.	35°C	
TIS' C1 CLI. CURVE TEMP.	35°C	
TIS2' C2 CLI. CURVE TEMP.	35°C	
TW_O PLATE W-OUTLET TEMP.	35°C	
TW_I PLATE W-OUTLET TEMP.	30°C	
◀ ADDRESS	4/9	▶

OPERATION PARAMETER		#00
Tbt1 BUFFERTANK_UP TEMP.	35°C	
Tbt2 BUFFERTANK_LOW TEMP.	35°C	
Tsolar	25°C	
IDU SOFTWARE	01-09-2019V01	
◀ ADDRESS	5/9	▶

OPERATION PARAMETER		#00
ODU MODEL	6kW	
COMP.CURRENT	12A	
COMP.FREQUENCY	24Hz	
COMP.RUN TIME	54 MIN	
COMP.TOTAL RUN TIME	1000Hrs	
EXPANSION VALVE	200P	
◀ ADDRESS	6/9	▶

OPERATION PARAMETER		#00
FAN SPEED	600R/MIN	
IDU TARGET FREQUENCY	46Hz	
FREQUENCY LIMITED TYPE	5	
SUPPLY VOLTAGE	230V	
DC GENERATRIX VOLTAGE	420V	
DC GENERATRIX CURRENT	18A	
◀ ADDRESS	7/9	▶

OPERATION PARAMETER		#00
TW_O PLATE W-OUTLET TEMP.	35°C	
TW_I PLATE W-INLET TEMP.	30°C	
T2 PLATE F-OUT TEMP.	35°C	
T2B PLATE F-IN TEMP.	35°C	
Th COMP. SUCTION TEMP.	5°C	
Tp COMP. DISCHARGE TEMP.	75°C	
◀ ADDRESS	8/9	▶

OPERATION PARAMETER		#00
T3 OUTDOOR EXCHANGE TEMP.	5°C	
T4 OUTDOOR AIR TEMP.	5°C	
TF MODULE TEMP.	55°C	
P1 COMP. PRESSURE	2300kPa	
ODU SOFTWARE	01-09-2018V01	
HMI SOFTWARE	01-09-2018V01	
◀ ADDRESS	9/9	▶

NOTE

The power consumption parameter is optional. If some parameter is not be activated in the system, the parameter will show "--".

The heat pump capacity is for reference only, not used to judge the ability of the unit. The accuracy of sensor is ±1°C The flow rates parameters are calculated according to the pump running parameters,the deviation is different at different flow rates,the maximum of deviation is 15%.The flow parameters are calculated according to the electrical parameters of the pump operation.

The operating voltage is different and the deviation is different.

The display valve is 0 when the voltage is less than 198V.

13.4 Error codes

When a safety device is activated, an error code(which doesn't include external failure) will be displayed on the user interface. A list of all errors and corrective actions can be found in the table below.

Reset the safety by turning the unit OFF and back ON.

In case this procedure for resetting the safety is not successful, contact your local dealer.

ERROR CODE	MALFUNCTION OR PROTECTION	FAILURE CAUSE AND CORRECTIVE ACTION
E 0	Water flow fault (after 3 times E8)	<ol style="list-style-type: none"> 1.The wire circuit is short connected or open. Reconnect the wire correctly. correctly. 2.Water flow rate s too low 3. Water flow switch is failed, switch is open or close continuously, change the water flow switch.
E 2	Communication fault between controller and hydraulic module	<ol style="list-style-type: none"> 1.Wire doesn't connect between wired controller and unit. connect the wire. 2.Communication wire sequence is not right. Reconnect the wire in the right sequence. 3.Whether there is a high magnetic eld or high power interfere, such as lifts, large power transformers, etc.. To add a barrier to protect the unit or to move the unit to the other place.
E 3	Final outlet water temp.sensor (T1) fault	<ol style="list-style-type: none"> 1.Check the resistance of the sensor 2.The T1 sensor connector is loosen. Reconnect it. 3.The T1 sensor connector is wet or there is water in. remove the water, make the connector dry. Add waterproof adhesive. 4.The T1 sensor failure, change a new sensor.
E 4	Water tank temp.sensor (T5) fault	<ol style="list-style-type: none"> 1.Check the resistance of the sensor 2.The T5 sensor connector is loosen. Reconnect it. 3.The T5 sensor connector is wet or there is water in. remove the water, make the connector dry. Add waterproof adhesive 4.The T5 sensor failure, change a new sensor. 5.If you want to close the domestic water heating when T5 sensor do not connected to the system, then T5 sensor can not be detected, refer to 10.5.1 "DHW MODE SETTING"
E 7	Buffer tank up temp.sensor (Tbt1) fault	<ol style="list-style-type: none"> "1.Check the resistance of the sensor. 2.The Tbt1 sensor connector is loosen,reconnect it. 3.The Tbt1 sensor connector is wet or there is water in,remove the water ,make the connector dry.Add waterproof adhesive. 4.The Tbt1 sensor failure,change a new sensor."
E 8	Water flow failure	<p>Check that all shut off valves of the water circuit are completely open.</p> <ol style="list-style-type: none"> 1. Check if the water lter needs cleaning. 2. Refer to "9.5 Filling water" 3. Make sure there is no air in the system(purge air). 4. Check the water pressure. The water pressure must be >1 bar. 5. Check that the pump speed setting is on the highest speed. 6. Make sure that the expansion vessel is not broken. 7. Check that the resistance in the water circuit is not too high for the pump (refer to "10.4 The circulation pump"). 8. If this error occurs at defrost operation (during space heating or domestic water heating), make sure that the backup heater power supply is wired correctly and that fuses are not blown. 9. Check that the pump fuse and PCB fuse are not blown.
E b	Solar temp.sensor (Tsolar) fault	<ol style="list-style-type: none"> "1.Check the resistance of the sensor. 2.The Tsolar sensor connector is loosen,reconnect it. 3.The Tsolar sensor connector is wet or there is water in,remove the water ,make the connector dry.Add waterproof adhesive. 4.The Tsolar sensor failure,change a new sensor."
E c	Buffer tank low temp.sensor (Tbt2) fault	<ol style="list-style-type: none"> "1.Check the resistance of the sensor. 2.The Tbt12 sensor connector is loosen,reconnect it. 3.The Tbt2 sensor connector is wet or there is water in,remove the water ,make the connector dry.Add waterproof adhesive. 4.The Tbt2 sensor failure,change a new sensor."
E d	Inlet water temp.sensor (Tw_in) malfunction	<ol style="list-style-type: none"> 1.Check the resistance of the sensor 2. The Tw_in sensor connector is loosen. Re connect it. 3.The Tw_in sensor connector is wet or there is water in. remove the water, make the connector dry. Add waterproof adhesive 4. The Tw_in sensor failure, change a new sensor. MODE SETTING"
E E	Hydraulic module EEPROM failure	<ol style="list-style-type: none"> 1. The EEPROM parameter is error, rewrite the EEPROM data. 2. EEPROM chip part is broken, change a new EEPROM chip part. 3. main control board of hydraulic module is broken, change a new PCB.
H 0	Communication fault between main board PCB B and main control board of hydraulic module	<ol style="list-style-type: none"> 1.wire doesn't connect between main control board PCB B and main control board of hydraulic module. connect the wire. 2.Communication wire sequence is not right. Reconnect the wire in the right sequence. 3. Whether there is a high magnetic eld or high power interfere, such as lifts, large power transformers, etc.. To add a barrier to protect the unit or to move the unit to the other place.

H 2	Refrigerant liquid temp. sensor (T2) fault	<p>Check the resistance of the sensor</p> <p>The T2 sensor connector is loosen. Reconnect it</p> <p>The T2 sensor connector is wet or there is water inside, make the connector dry. Add waterproof insulation</p> <p>The T2 sensor failure, change with a new sensor.</p>
H 3	Refrigerant gas temp. sensor (T2B) fault	<ol style="list-style-type: none"> 1. Check the resistance of the sensor 2. The T2B sensor connector is loosen. Reconnect it. 3. The T2B sensor connector is wet or there is water in. remove the water, make the connector dry. Add waterproof adhesive
H 5	Room temp.sensor (Ta) fault	<ol style="list-style-type: none"> 4. The T2B sensor failure, change a new sensor. 1. Check the resistance of the sensor. 2. The Ta sensor is in the interface. 3. The Ta sensor failure: change a new sensor or change a new interface, or reset the Ta, connect a new Ta from the hydraulic
H 9	Outlet water for zone 2 temp.sensor (Tw2) fault	<ol style="list-style-type: none"> 1. Check the resistance of the sensor. 2. The Tw2 sensor connector is loosen. Reconnect it. 3. The Tw2 sensor connector is wet or there is water in. Remove the water, make the connector dry. add waterproof adhesive. 4. The Tw2 sensor failure, change a new sensor.
H R	Outlet water temp.sensor (Tw_out) fault	<ol style="list-style-type: none"> 1. The TW_out sensor connector is loosen. Reconnect it. 2. The TW_out sensor connector is wet or there is water in. remove the water, make the connector dry. add waterproof adhesive. 3. The TW_out sensor failure, change a new sensor
H b	Three times "PP" protection and Tw_out<7°C	The same to "PP".
H d	Communication fault between hydraulic module parallel	<ol style="list-style-type: none"> 1. The signal wires of slave units and master unit are not effectively connected. After checking all signal wires are well connected, and making sure there is no strong electricity or strong magnetic interference, power on again; 2. There are two or more outdoor unit connected to the wired controller. After removing the excess wired controller and keep only the wired controller of the master unit, power on again; 3.The power-on interval between the master unit and the slave unit is longer than 2min. After ensuring that the interval between the power-on of all the master units and slave units is less than 2min, power on again; 4.The addresses of master unit and slave units are repeated: by pressing the SW2 button on main board once on slave units, the address code of the slave unit will be displayed on the digital display (normally address code, one of 1, 2, 3 ... 15 will be shown on main board), check whether there is a duplicate address. If there is a duplicate address code, after powering off the system, set the S4-1 to "ON" on master outdoor unit main board or the slave outdoor unit main board which display "Hd" error(refer to 10.1.1 FUNCTION SEETING).Power on again,all the units last for 5 minutes without "Hd" error, power off again and set the S4-1 to "OFF". The system will recover.
H E	Communication error between main board and thermostat transfer board	RT/Ta PCB is set to be valid on user interface but thermostat transfer board is not connected or the communication between thermostat transfer board and main board is not effectively connected. If thermostat transfer board is not needed, set the RT/Ta PCB to invalid. If thermostat transfer board is needed, please connect it to main board and make sure the communication wire is connected well and there is no strong electricity or strong magnetic interference.
P 5	Inlet water temp.sensor (Tw_in) malfunction	<ol style="list-style-type: none"> 1. Check that all shut off valves of the water circui are completely open. 2. Check if the water filter needs cleaning. 3. Referto" 9.5 Filling water" 4. Make sure there is no air in the system (purge air). 5. Check the water pressure. The water pressure must be >1 bar(water is cold). 6. Check that the pump speed setting is on the highest speed. 7. Make sure that the expansion vessel is not broken. 8. Check that the resistance in the water circui is not too high for the pump. (referto "10.4 The circulation pump").
P b	Anti-freeze mode	Unit will return to the normal operation automatically
P P	Tw_out - Tw_in unusual protection	<ol style="list-style-type: none"> 1. Check the resistance of the two sensor. 2. Check the two sensors locations. 3. The water inlet/outlet sensor wire connector is loosen. Reconnect it. 4. The water inlet/outlet (TW_in /TW_out) sensor is broken, Change a new sensor. 5. Four-wayvalve is blocked. Restart the unit again to let the valve change the direction. 6. Four-wayvalve is broken, change a new valve.

⚠ CAUTION In winter if the unit has E0 and Hb failure and the unit is not repaired in time, the water pump and pipeline system may be damaged by freezing, so E0 and Hb failures must be repaired in time

E 1	Phase loss or neutral wire and live wire are connected reversely (only for three phase unit)	<ol style="list-style-type: none"> 1. Check the power supply cables should be conneted stable, avoid phase loss. 2. Check whether the sequence of neutral wire and live wire are connected reversely
E 5	The condenser outlet refrigerant temperature sensor (T3) error	<ol style="list-style-type: none"> 1. The T3 sensor connector is loosen. Reconnect it. 2. The T3 sensor connector is wet or there is water in. remove the water, make the connector dry. Add waterproof adhesive. 3. The T3 sensor failure, change a new sensor
E 6	The ambient temperature sensor (T4) error	<ol style="list-style-type: none"> 1. The T4 sensor connector is loosen. Reconnect it. 2. The T4 sensor connector is wet or there is water in. remove the water, make the connector dry. Add waterproof adhesive. 3. The T4 sensor failure, change a new sensor.
E 9	Suction temperature sensor (Th) error	<ol style="list-style-type: none"> 1. The Th sensor connector is loosen. Re connect it. 2. The Th sensor connector is wet or there is water in. remove the water, make the connector dry. Add waterproof adhesive. 3. The Th sensor failure, change a new sensor.
E R	Discharge temperature sensor (Tp) error	<ol style="list-style-type: none"> 1. wire doesn't connect between main control board PCB B and main control board of hydraulic module. connect the wire. 2. Communication wire sequence is not right. Reconnect the wire in the right sequence. 3. Whether there is a high magnetic field or high power interfere, such as lifts, large power transformers, etc.. To add a barrier to protect the unit or to move the unit to the other place.
H 0	Communication fault between main board PCB B and main control board of hydraulic module	<ol style="list-style-type: none"> 1. wire doesn't connect between main control board PCB B and main control board of hydraulic module. connect the wire. 2. Communication wire sequence is not right. Reconnect the wire in the right sequence. 3. Whether there is a high magnetic field or high power interfere, such as lifts, large power transformers, etc.. To add a barrier to protect the unit or to move the unit to the other place.
H 1	Communication error between inverter module PCB A and main control board PCB B	<ol style="list-style-type: none"> 1. Whether there is power connected to the PCB and driven board. Check the inverter module PCB indicator light is on or off. If Light is off, reconnect the power supply wire. 2. if light is on, check the wire connection between inverter module PCB and main control board PCB, if the wire loosen or broken, reconnect the wire or change a new wire
H 4	Three times P6 (L0/L1) protect	The sum of the number of times L0 and L1 appear in an hour equals three. See L0 and L1 for fault handling methods
H 5	The DC fan failure	<ol style="list-style-type: none"> 1. Strong wind or typhoon below toward to the fan, to make the fan running in the opposite direction. Change the unit direction or make shelter to avoid typhoon below to the fan. 2. fan motor is broken, change a new fan motor.
H 7	Voltage protection	<ol style="list-style-type: none"> 1. Whether the power supply input is in the available range. 2. Power off and power on for several times rapidly in short time. Remain the unit power off for more than 3 minutes than power on. 3. the circuit defect part of Main control board is defective. Replace a new Main PCB.
H 8	Pressure sensor failure	<ol style="list-style-type: none"> 1. Pressure sensor connector is loosen, reconnect it. 2. Pressure sensor failure. change a new sensor.
H F	Suction temperature sensor (Th) error	<ol style="list-style-type: none"> 1. The EEprom parameter is error, rewrite the EEprom data. 2. EEprom chip part is broken, change a new EEprom chip part. 3. Inverter module board is broken, change a new PCB.
H H	H6 displayed 10 times in 2 hours Refer to H6	Refer to H6
H P	Low pressure protection in cooling $P_e < 0.6$ occurred 3 times in an hour	Refer to P0

P 0	Low pressure switch protection	<ol style="list-style-type: none"> 1. System is lack of refrigerant volume. Charge the refrigerant in right volume. 2. When at heating mode or DHW mode, the outdoor heating exchanger is dirty or something is block on the surface. Clean the outdoor heating exchanger or remove the obstruction. 3. The water flow is too low in cooling mode.increase the water flow. 4. Electrical expansion valve locked or winding connector is loosen. Tap-tap the valve body and plug in/ plug off the connector for several times to make sure the valve is working correctly. 	
P 1	High pressure switch protection	<ol style="list-style-type: none"> 1. Heating mode, DHW mode: <ol style="list-style-type: none"> 1. The water flow is low; water temp is high, whether there is air in the water system. Release the air. 2. Water pressure is lower than 0.1Mpa, charge the water to let the pressure in the range of 0.15~0.2Mpa. 3. Over charge the refrigerant volume. Recharge the refrigerant in right volume. 4. Electrical expansion valve locked or winding connector is loosen. Tap-tap the valve body and plug in/ plug off the connector for several times to make sure the valve is working correctly. And install the winding in the right location DHW mode: Water tank heat exchanger is smaller .Cooling mode: <ol style="list-style-type: none"> 1. Heat exchanger cover is not removed. Remove it. 2. Heat exchanger is dirty or something is block on the surface. Clean the heat exchanger or remove the obstruction. 	
P 3	Compressor overcurrent protection	<ol style="list-style-type: none"> 1. The same reason to P1. 2. Power supply voltage of the unit is low, increase the power voltage to the required range. 	
P 4	High discharge temperature protection	<ol style="list-style-type: none"> 1. The same reason to P1. 2. TW_out temp.sensor is loosen Reconnect it.. 3. T1 temp.sensor is loosen. Reconnect it. 4. T5 temp.sensor is loosen. Reconnect it.. 	
P d	High temperature protection of refrigerant outlet temp of condenser.	<ol style="list-style-type: none"> Heat exchanger cover is not removed. Remove it. 2. Heat exchanger is dirty or something is block on the surface. Clean the heat exchanger or remove the obstruction. 3. There is no enough space around the unit for heat exchanging. 4. Fan motor is broken, replace a new one. 	
E 7	Transducer module temperature too high protection	<ol style="list-style-type: none"> 1. Power supply voltage of the unit is low, increase the power voltage to the required range. 2. The space between the units is too narrow for heat exchange. Increase the space between the units. 3. Heat exchanger is dirty or something is block on the surface. Clean the heat exchanger or remove the obstruction. 4. Fan is not running. Fan motor or fan is broken, Change a new fan or fan motor. 5. Water flow rate is low, there is air in system, or pump head is not enough. Release the air and reselect the pump. 6. Water outlet temp.sensor is loosen or broken, reconnect it or change a new one. 	
F 1	Low DC generatrix voltage protection	<ol style="list-style-type: none"> 1. Check the power supply. 2. If the power supply is OK, check if LED light is OK, check the voltage PN, if it is 380V, the problem usually comes from the main board. And if the light is OFF, disconnect the power, check the IGBT, check those dioxides, if the voltage is not correct, the inverter board is damaged, change it. 3. And if those IGBT are OK, which means the inverter board is OK, power form rectier bridge is not correct, check the bridge. (Same method as IGBT, disconnect the power, check those dioxides are damaged or not). 4. Usually if F1 exist when compressor start, the possible reason is main board. If F1 exist when fan start, it may be because of inverter board. 	
b H	PED PCB failure.	<ol style="list-style-type: none"> 1. After 5 minutes of power-o interval, power on again and observe whether it can be recovered; 2. If it can't be restored, replace PED safety plate, power on again, and observe whether it can be restored; 3. If it can not be recovered, the IPM module board should be replaced. 	
P 6	L 0	Module protection	<ol style="list-style-type: none"> 1. Check the Heat pump system pressure. 2. Check the phase resistance of compressor. 3. Check the U-V-W power line connection sequence between the inverter board and the compressor. 4. Check the L1-L2-L3 power line connection between the inverter board and the Filter board. 5. Check the inverter board.
	L 1	DC generatrix low voltage protection	
	L 2	DC generatrix high voltage protection	
	L 4	MCE malfunction	
	L 5	Zero speed protection	
	L 8	Speed difference >15Hz protection between the front and the back clock	
L 9	Speed difference >15Hz protection between the real and the setting speed		

14 TECHNICAL SPECIFICATIONS

14.1 General

Model	1-phase 4/6 kW	1-phase 8/10 kW	1-phase 12/14/16 kW	3-phase 12/14/16 kW
Nominal capacity	Refer to the Technical Data			
Dimensions HxWxD	792×1295×429mm	945×1385×526mm	945×1385×526mm	945×1385×526mm
Weight (without backup heater)				
Net weight	98kg	121kg	144kg	160kg
Gross weight	121kg	148kg	170kg	188kg
Connections				
water inlet/outlet	G1"BSP	G5/4"BSP	G5/4"BSP	G5/4"BSP
Water drain	hose nipple			
Expansion vessel				
volume	8l			
Maximum working pressure (MWP)	8 bar			
Pump				
Type	water cooled	water cooled	water cooled	water cooled
No. of speed	Variable speed	Variable speed	Variable speed	Variable speed
Internal water volume	3.2l	3.2l	2.0l	2.0l
Minimum hydraulic circuit volume (excluding internal water volume and with zone valves closed)	40l			
Pressure relief valve water circuit	3 bar			
Operation range - water side				
heating	+12~+65°C			
cooling	+5~+25°C			
Operation range - air side				
heating	-25~35°C			
cooling	-5~43°C			
domestic hot water by heat pump	-25~43°C			

14.2 Electrical specification

Model		1-phase 4/6/8/10/12/14/16kW	3-phase 12/14/16kW
Standard unit	Power Supply	220-240V~ 50Hz	380-415V 3N~ 50Hz
	Nominal Running Current	See "9.7.4 Safety device requirement"	
Backup heater	Power Supply	See "9.7.4 Safety device requirement"	
	Nominal Running Current	See "9.7.4 Safety device requirement"	

15 INFORMATION SERVICING

1) Checks to the area

Prior to beginning work on systems containing flammable refrigerants, safety checks are necessary to ensure that the risk of ignition is minimised. For repair to the refrigerating system, the following precautions shall be complied with prior to conducting work on the system.

2) Work procedure

Works shall be undertaken under a controlled procedure so as to minimise the risk of a flammable gas or vapour being present while the work is being performed.

3) General work area

All maintenance staff and others working in the local area shall be instructed on the nature of work being carried out. Work in confined spaces shall be avoided. The area around the work space shall be sectioned off. Ensure that the conditions within the area have been made safe by control of flammable material.

4) Checking for presence of refrigerant

The area shall be checked with an appropriate refrigerant detector prior to and during work, to ensure the technician is aware of potentially flammable atmospheres. Ensure that the leak detection equipment being used is suitable for use with flammable refrigerants, i.e. no sparking, adequately sealed or intrinsically safe.

5) Presence of re extinguisher

If any hot work is to be conducted on the refrigeration equipment or any associated parts, appropriate re extinguishing equipment shall be available to hand. Have a dry power or CO₂ re extinguisher adjacent to the charging area.

6) No ignition sources

No person carrying out work in relation to a refrigeration system which involves exposing any pipe work that contains or has contained flammable refrigerant shall use any sources of ignition in such a manner that it may lead to the risk of re or explosion. All possible ignition sources, including cigarette smoking, should be kept sufficiently far away from the site of installation, repairing, removing and disposal, during which flammable refrigerant can possibly be released to the surrounding space. Prior to work taking place, the area around the equipment is to be surveyed to make sure that there are no flammable hazards or ignition risks. NO SMOKING signs shall be displayed.

7) Ventilated area

Ensure that the area is in the open or that it adequately ventilated before breaking into the system or conducting any hot work. A degree of ventilation shall continue during the period that the work is carried out. The ventilation should safely disperse any released refrigerant and preferably expel it externally into the atmosphere.

8) Checks to the refrigeration equipment

Where electrical components are being changed, they shall be fit for the purpose and to the correct specification. At all times the manufacturer's maintenance and service guidelines shall be followed. If in doubt consult the manufacturer's technical department for assistance. The following checks shall be applied to installations using flammable refrigerants.

- The charge size is in accordance with the room size within which the refrigerant containing parts are installed.
- The ventilation machinery and outlets are operating adequately and are not obstructed.
- If an indirect refrigerating circuit is being used, the secondary circuits shall be checked for the presence of refrigerant; marking to the equipment continues to be visible and legible.
- Marking and signs that are illegible shall be corrected.
- Refrigeration pipe or components are installed in a position where they are unlikely to be exposed to any substance which may corrode refrigerant containing components, unless the components are constructed of materials which are inherently resistant to being corroded or are suitably protected against being so corroded.

9) Checks to electrical devices

Repair and maintenance to electrical components shall include initial safety checks and component inspection procedures. If a fault exists that could compromise safety, then no electrical supply shall be connected to the circuit until it is satisfactorily dealt with. If the fault cannot be corrected immediately but it is necessary to continue operation, and adequate temporary solution shall be used. This shall be reported to the owner of the equipment so all parties are advised.

Initial safety checks shall include:

- That capacitors are discharged: this shall be done in a safe manner to avoid possibility of sparking.
- That there no live electrical components and wiring are exposed while charging, recovering or purging the system.
- That there is continuity of earth bonding.

10) Repairs to sealed components

a) During repairs to sealed components, all electrical supplies shall be disconnected from the equipment being worked upon prior to any removal of sealed covers, etc. If it is absolutely necessary to have an electrical supply to equipment during servicing, then a permanently operating form of leak detection shall be located at the most critical point to warn of a potentially hazardous situation.

b) Particular attention shall be paid to the following to ensure that by working on electrical components, the casing is not altered in such a way that the level of protection is affected. This shall include damage to cables, excessive number of connections, terminals not made to original specification, damage to seals, incorrect fitting of glands, etc.

- Ensure that apparatus is mounted securely.
- Ensure that seals or sealing materials have not degraded such that they no longer serve the purpose of preventing the ingress of flammable atmospheres. Replacement parts shall be in accordance with the manufacturer's specification.



NOTE

The use of silicon sealant may inhibit the effectiveness of some types of leak detection equipment. Intrinsically safe components do not have to be isolated prior to working on them.

11) Repair to intrinsically safe components

Do not apply any permanent inductive or capacitance loads to the circuit without ensuring that this will not exceed the permissible voltage and current permitted for the equipment in use. Intrinsically safe components are the only types that can be worked on while live in the presence of a flammable atmosphere. The test apparatus shall be at the correct rating. Replace components only with parts specified by the manufacturer. Other parts may result in the ignition of refrigerant in the atmosphere from a leak.

12) Cabling

Check that cabling will not be subject to wear, corrosion, excessive pressure, vibration, sharp edges or any other adverse environmental effects. The check shall also take into account the effects of aging or continual vibration from sources such as compressors or fans.

13) Detection of flammable refrigerants

Under no circumstances shall potential sources of ignition be used in the searching for or detection of refrigerant leaks. A halide torch (for any other detector using a naked flame) shall not be used.

14) Leak detection methods

The following leak detection methods are deemed acceptable for systems containing flammable refrigerants. Electronic leak detectors shall be used to detect flammable refrigerants, but the sensitivity may not be adequate, or may need re-calibration. (Detection equipment shall be calibrated in a refrigerant-free area.) Ensure that the detector is not a potential source of ignition and is suitable for the refrigerant. Leak detection equipment shall be set at a percentage of the LFL of the refrigerant and shall be calibrated to the refrigerant employed and the appropriate percentage of gas (25% maximum) is confirmed. Leak detection fluids are suitable for use with most refrigerants but the use of detergents containing chlorine shall be avoided as the chlorine may react with the refrigerant and corrode the copper pipe-work. If a leak is suspected, all naked flames shall be removed or extinguished. If a leakage of refrigerant is found which requires brazing, all of the refrigerant shall be recovered from the system, or isolated (by means of shut off valves) in a part of the system remote from the leak. Oxygen free nitrogen (OFN) shall then be purged through the system both before and during the brazing process.

15) Removal and evacuation

When breaking into the refrigerant circuit to make repairs or for any other purpose conventional procedures shall be used. However, it is important that best practice is followed since flammability is a consideration. The following procedure shall be adhered to:

- Remove refrigerant;
- Purge the circuit with inert gas;
- Evacuate;
- Purge again with inert gas;
- Open the circuit by cutting or brazing.

The refrigerant charge shall be recovered into the correct recovery cylinders. The system shall be flushed with OFN to render the unit safe. This process may need to be repeated several times.

Compressed air or oxygen shall not be used for this task.

Flushing shall be achieved by breaking the vacuum in the system with OFN and continuing to fill until the working pressure is achieved, then venting to atmosphere, and finally pulling down to a vacuum. This process shall be repeated until no refrigerant is within the system.

When the final OFN charge is used, the system shall be vented down to atmospheric pressure to enable work to take place.

This operation is absolutely vital if brazing operations on the pipe-work are to take place.

Ensure that the outlet for the vacuum pump is not closed to any ignition sources and there is ventilation available. Ensure that the outlet for the vacuum pump is not closed to any ignition sources and there is ventilation available.

16) Charging procedures

In addition to conventional charging procedures, the following requirements shall be followed:

- Ensure that contamination of different refrigerants does not occur when using charging equipment. Hoses or lines shall be as short as possible to minimize the amount of refrigerant contained in them.
- Cylinders shall be kept upright.
- Ensure that the refrigeration system is earthed prior to charging the system with refrigerant.
- Label the system when charging is complete (if not already).
- Extreme care shall be taken not to overfill the refrigeration system.
- Prior to recharging the system it shall be pressure tested with OFN. The system shall be leak tested on completion of charging but prior to commissioning. A follow up leak test shall be carried out prior to leaving the site.

17) Decommissioning

Before carrying out this procedure, it is essential that the technician is completely familiar with the equipment and all its detail. It is recommended good practice that all refrigerants are recovered safely. Prior to the task being carried out, an oil and refrigerant sample shall be taken.

In case analysis is required prior to re-use of reclaimed refrigerant. It is essential that electrical power is available before the task is commenced.

- a) Become familiar with the equipment and its operation.

- b) Isolate system electrically
- c) Before attempting the procedure ensure that:
 - Mechanical handling equipment is available, if required, for handling refrigerant cylinders.
 - All personal protective equipment is available and being used correctly.
 - The recovery process is supervised at all times by a competent person.

Recovery equipment and cylinders conform to the appropriate standards.

- d) Pump down refrigerant system, if possible.
- e) If a vacuum is not possible, make a manifold so that refrigerant can be removed from various parts of the system.
- f) Make sure that cylinder is situated on the scales before recovery takes place.
- g) Start the recovery machine and operate in accordance with manufacturer's instructions.
- h) Do not overfill cylinders. (No more than 80% volume liquid charge).
- i) Do not exceed the maximum working pressure of the cylinder, even temporarily.
- j) When the cylinders have been filled correctly and the process completed, make sure that the cylinders and the equipment are removed from site promptly and all isolation valves on the equipment are closed off.
- k) Recovered refrigerant shall not be charged into another refrigeration system unless it has been cleaned and checked.

18) Labelling

Equipment shall be labelled stating that it has been de-commissioned and emptied of refrigerant. The label shall be dated and signed. Ensure that there are labels on the equipment stating the equipment contains flammable refrigerant.

19) Recovery

When removing refrigerant from a system, either for service or decommissioning, it is recommended good practice that all refrigerants are removed safely.

When transferring refrigerant into cylinders, ensure that only appropriate refrigerant recovery cylinders are employed. Ensure that the correct numbers of cylinders for holding the total system charge are available. All cylinders to be used are designated for the recovered refrigerant and labelled for that refrigerant (i.e. special cylinders for the recovery of refrigerant). Cylinders shall be complete with pressure relief valve and associated shut-off valves in good working order.

Empty recovery cylinders are evacuated and, if possible, cooled before recovery occurs.

The recovery equipment shall be in good working order with a set of instructions concerning the equipment that is at hand and shall be suitable for the recovery of flammable refrigerants. In addition, a set of calibrated weighing scales shall be available and in good working order.

Hoses shall be complete with leak-free disconnect couplings and in good condition. Before using the recovery machine, check that it is in satisfactory working order, has been properly maintained and that any associated electrical components are sealed to prevent ignition in the event of a refrigerant release. Consult manufacturer if in doubt.

The recovered refrigerant shall be returned to the refrigerant supplier in the correct recovery cylinder, and the relevant Waste Transfer Note arranged. Do not mix refrigerants in recovery units and especially not in cylinders.

If compressors or compressor oils are to be removed, ensure that they have been evacuated to an acceptable level to make certain that flammable refrigerant does not remain within the lubricant. The evacuation process shall be carried out prior to returning the compressor to the suppliers. Only electric heating to the compressor body shall be employed to accelerate this process. When oil is drained from a system, it shall be carried out safely.

20) Transportation, marking and storage for units

Transport of equipment containing flammable refrigerants Compliance with the transport regulations.

Marking of equipment using signs Compliance with local regulations.

Disposal of equipment using flammable refrigerants Compliance with national regulations.

Storage of equipment/appliances.

The storage of equipment should be in accordance with the manufacturer's instructions.

Storage of packed (unsold) equipment .

Storage package protection should be constructed such that mechanical damage to the equipment inside the package will not cause a leak of the refrigerant charge.

The maximum number of pieces of equipment permitted to be stored together will be determined by local regulations.

ANNEX A: Refrigerant cycle

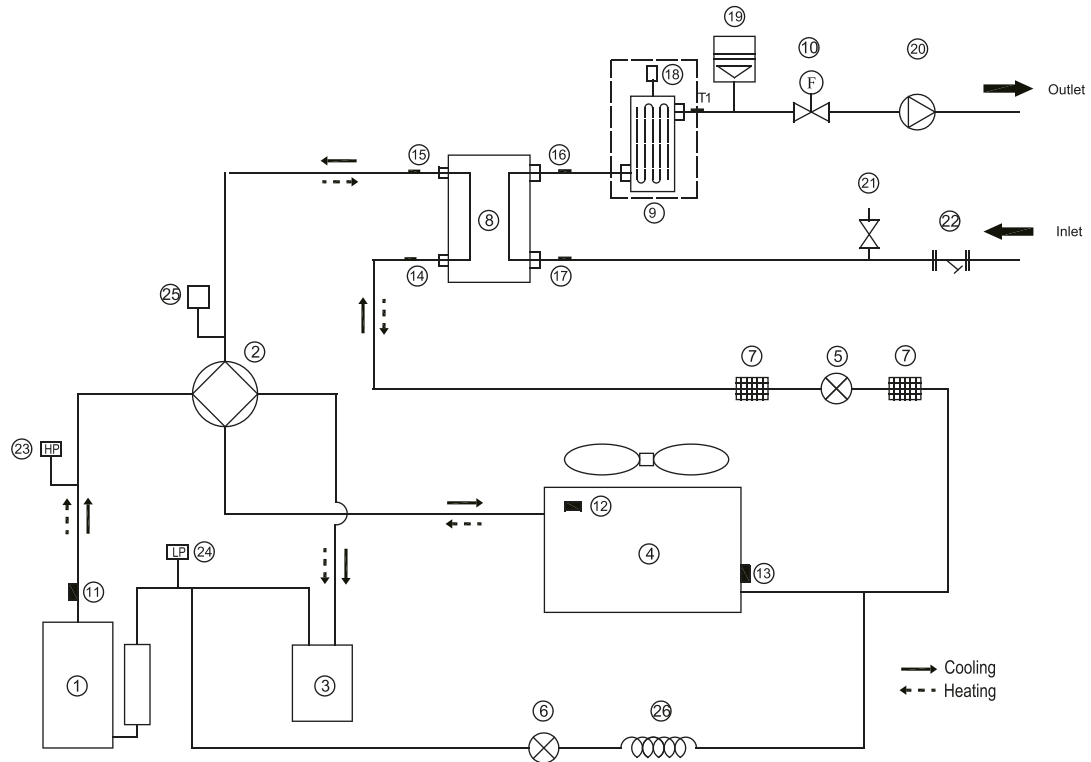

item	Description	item	Description
1	Compressor	14	Refrigerant inlet (liquid pipe) temperature sensor
2	4-Way valve	15	Refrigerant outlet (gas pipe) temperature sensor
3	Gas-liquid separator	16	Water outlet temperature sensor
4	Air side heat exchanger	17	Water Inlet temperature sensor
5	Electronic expansion valve	18	Automatic air purge valve
6	Single-way electromagnetic valve	19	Expansion vessel
7	Strainer	20	Circulating pump
8	Water Side Heat Exchanger (Plate Heat Exchange)	21	Pressure relief valve
9	Backup heater (optional)	22	Y-shape filter
10	Flow switch	23	High Pressure Switch
11	Discharge gas sensor	24	Low Pressure Switch
12	Outdoor temperature sensor	25	Pressure sensor
13	Evaporation sensor in heating (Condenser sensor in cooling)	26	Capillary

ANNEX B: Electrically controlled wiring diagram 1-phase 4/6/8/10kW

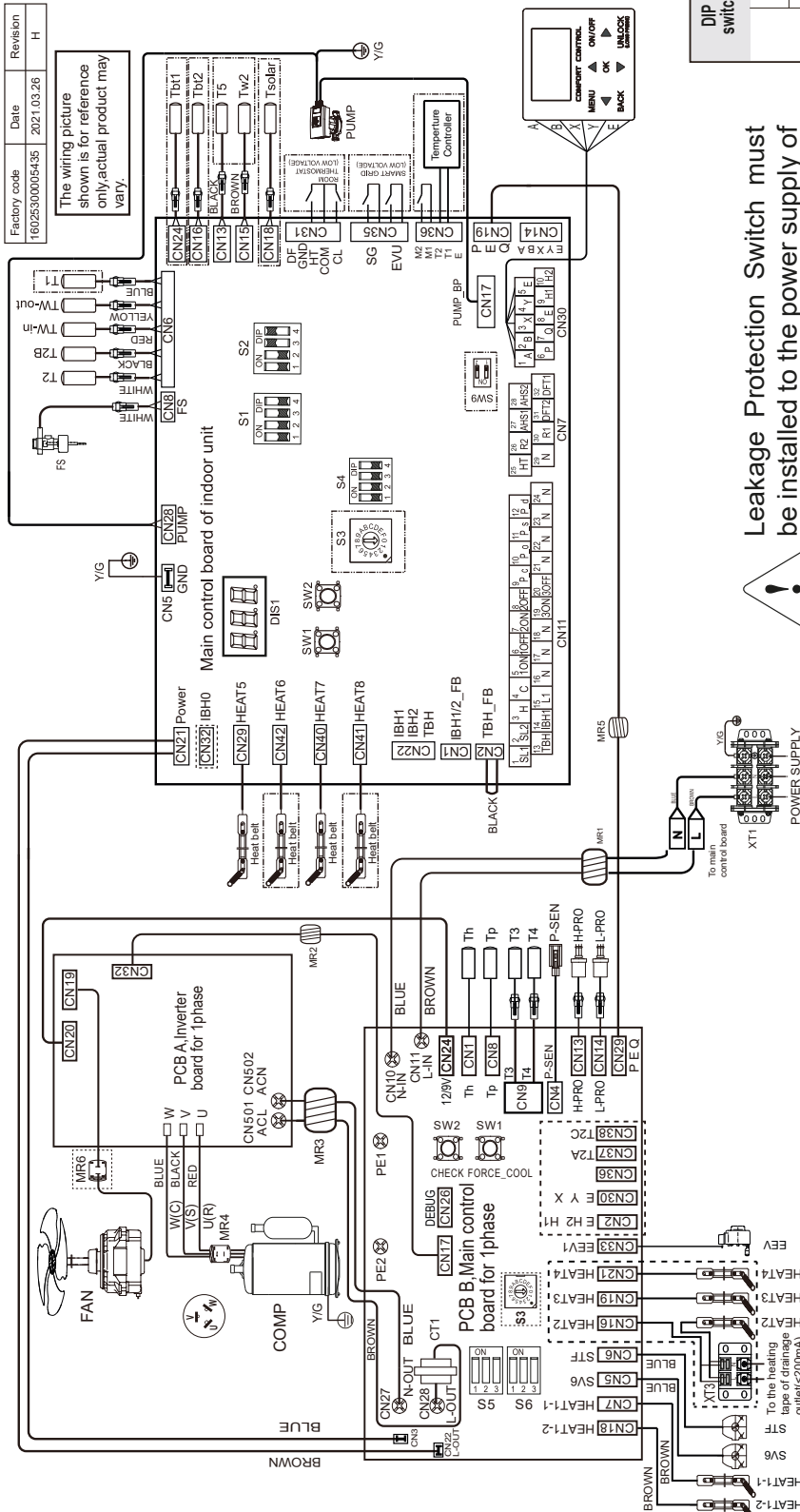

Factory code	Date	Revision
16025300006435	2021.03.26	H

The wiring picture shown is for reference only actual product may vary.

DJP switch	ON = 1	OFF = 0	Factory defaults
S1	Reserved	Reserved	OFF
	Reserved	Reserved	OFF
	0/0 = without IBH and AHS 0/1= with AHS for heat mode 1/0= with IBH 1/1= with AHS for heat mode and DHW mode		3: OFF 4: OFF
S2	Start PUMP O after six hours will be invalid	Start PUMP O after six hours will be valid	OFF
	Without TBH	With TBH	OFF
	0/0 = variable speed pump, max head 8.5m (GRUNDFOS) 0/1= constant speed pump (WILO) 1/0= variable speed pump, max head 10.5m (GRUNDFOS) 1/1= variable speed pump, max head 9.0m (WIL0)		3: ON 4: ON
S4	Reserved	Reserved	1: OFF 2: OFF
	Reserved	Reserved	3: OFF 4: OFF

Leakage Protection Switch must be installed to the power supply of the unit.
Equipment must be grounded.



- Operate the switches and push buttons with an insulated stick (such as a closed ball-point pen) to avoid touching of live parts.
- Querying external parameters and setting menu parameters are only allowed on the wire controller.



FACTORY SETTING	S6-1	S6-2	S6-3
4KW	ON 1 2 3	0	0
6KW	ON 1 2 3	1	0
8KW	ON 1 2 3	0	1
10KW	ON 1 2 3	1	0

Annex C: Electrically controlled wiring diagram 1-phase 12/14/16kW

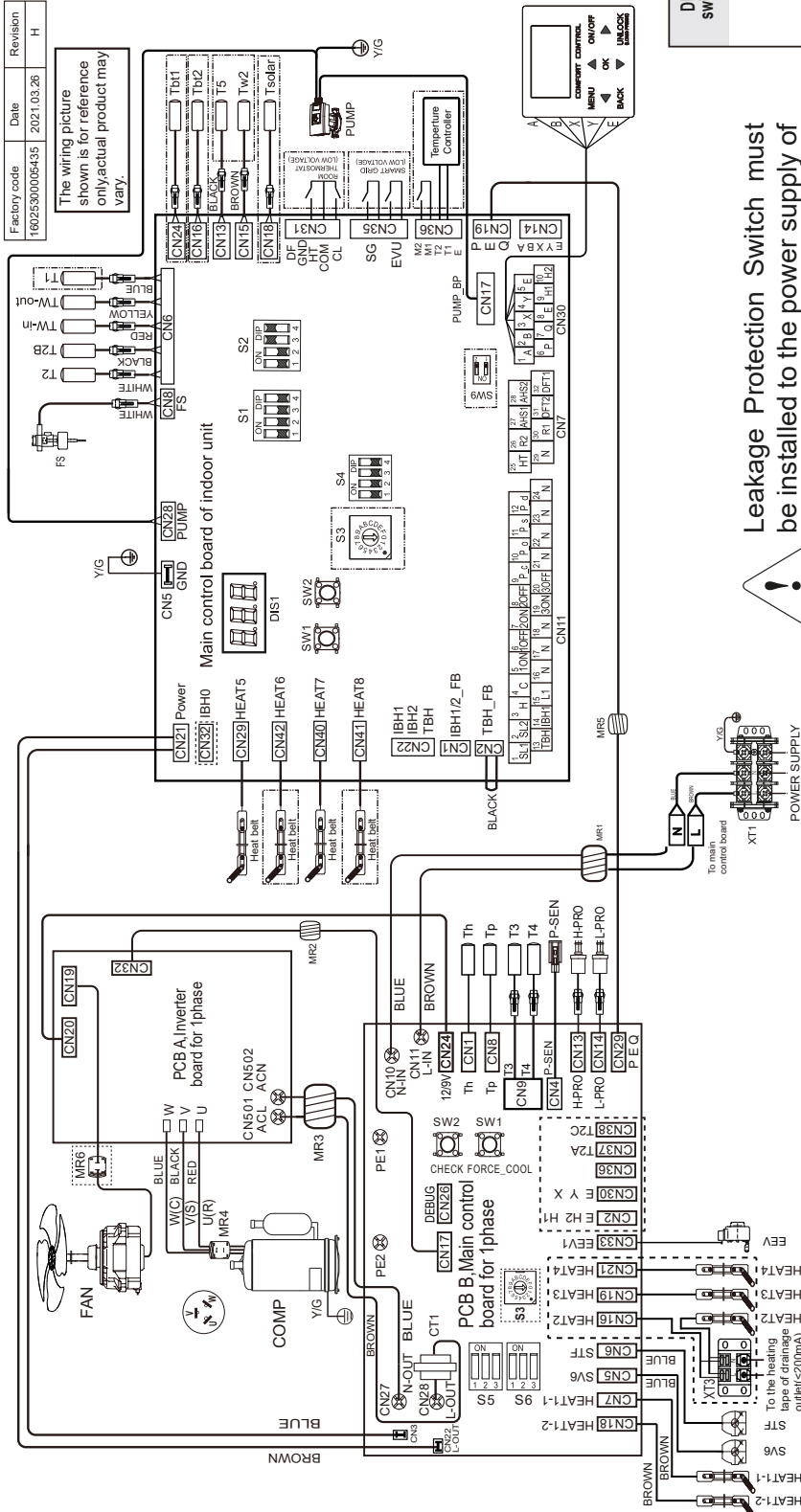

Factory code	Date	Revision
16025300005435	2021.03.26	H

The wiring picture shown is for reference only, actual product may vary.

DIP switch	ON = 1	OFF = 0	Factory defaults
S1	1	Reserved	OFF
	2	Reserved	OFF
	3/4	0/0 = without IBH and AHS 0/1 = with AHS for heat mode 1/0 = with IBH 1/1 = with AHS for heat mode and DHW mode	Reserved
S2	1	Start PUMP 0 after six hours will be invalid	OFF
	2	Without TBH	OFF
	3/4	0/0 = variable speed pump, max head 8.5m (GRUNDFOS) 0/1 = constant speed pump (WILO) 1/0 = variable speed pump, max head 10.5m (GRUNDFOS) 1/1 = variable speed pump, max head 9.0m (WILO)	Reserved
S4	1/2	Reserved	1: OFF 2: OFF
	3/4	Reserved	3: OFF 4: OFF

Leakage Protection Switch must be installed to the power supply of the unit.
Equipment must be grounded.



OUTDOOR UNIT POWER SUPPLY

- Operate the switches and push buttons with an insulated stick (such as a closed ball-point pen) to avoid touching of live parts.
- Querying external parameters and setting menu parameters are only allowed on the wire controller.



FACTORY SETTING	S6-1	S6-2	S6-3
12KW	0	0	1
14KW	1	0	1
16KW	0	1	1

Annex D: Electrically controlled wiring diagram 3-phase 12/14/16kW

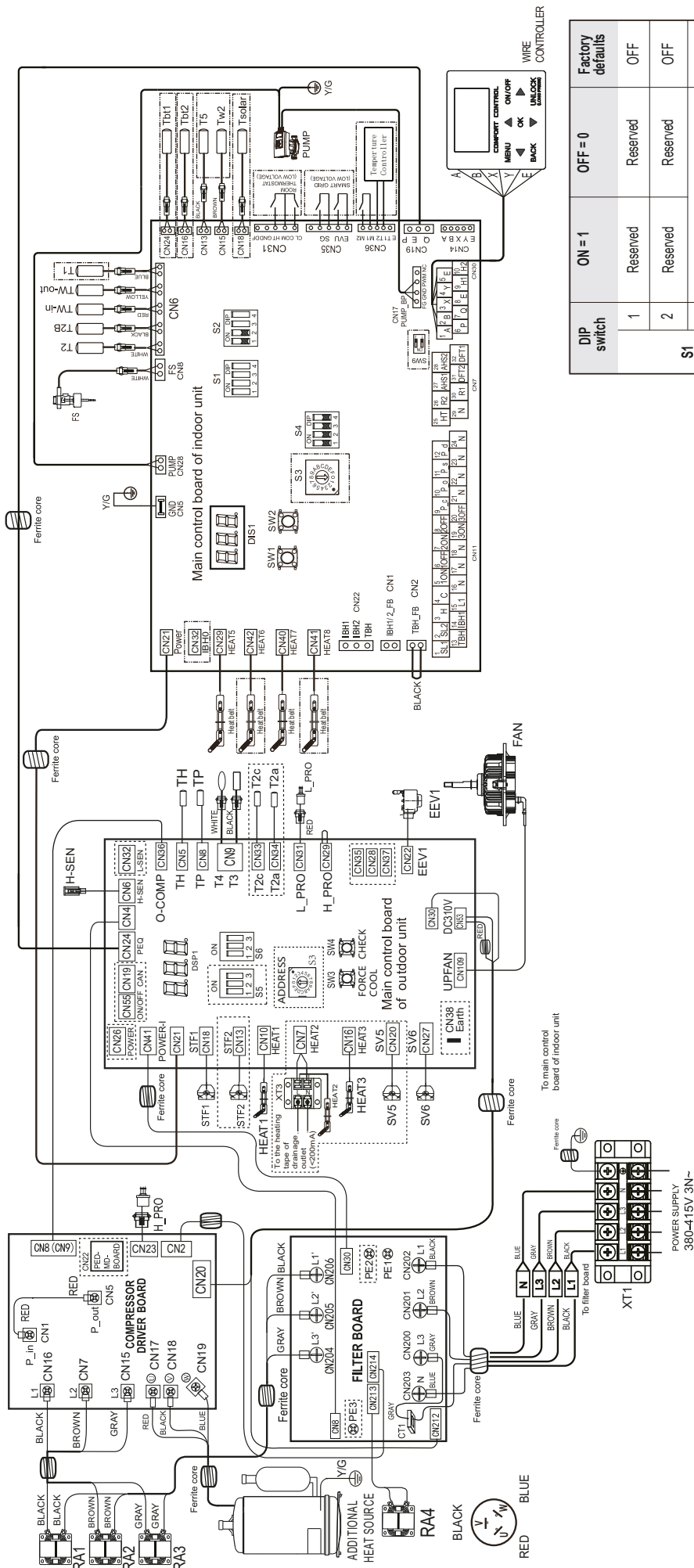

Leakage Protection Switch must be installed to the power supply of the unit.
Equipment must be grounded.



- Operate the switches and push buttons with an insulated stick (such as a closed ball-point pen) to avoid touching of live parts.
- Querying external parameters and setting menu parameters are only allowed on the wire controller.



FACTORY SETTING	S6-1	S6-2	S6-3
12KW	0	0	0
14KW	1	0	0
16KW	0	1	0

DIP switch	ON = 1	OFF = 0	Factory defaults
S1	1	Reserved	OFF
	2	Reserved	OFF
	3/4	0/0 = without IBH and AHS 0/1 = with AHS for heat mode 1/0 = with IBH 1/1 = with AHS for heat mode and DHW mode	3: OFF 4: OFF
	1	Start PUMP O after six hours will be invalid	OFF
S2	2	Without TBH	With TBH
	3/4	0/0 = variable speed pump, max head 8.5m (GRUNDFOS) 0/1 = constant speed pump (WILCO) 1/0 = variable speed pump, max head 10.5m (GRUNDFOS) 1/1 = variable speed pump, max head 9.0m (WILCO)	3: ON 4: ON
S4	1/2	Reserved	1: OFF 2: OFF
	3/4	Reserved	3: OFF 4: OFF