

## The compliant way of charging Hybrid PV Systems from Low Rate Tariffs

During the shorter winter days, there may not be enough generation from a PV system to cover the base load of a property or to add significant electrical charge into a Hybrid battery.

To combat this issue and to make the most of your investment, it would be advisable to top up the charge on these batteries with electricity purchased at a lower rate tariff. This stored energy can then be used during periods where higher tariffs are usually charged, making the best use for your system and significantly reducing the return on your investment.

### Example Additional Savings

Assuming that a PV system can only charge the batteries to full capacity during the summer months, and can be topped up by 2kW per day from lower rate tariffs between October and March:

Example energy prices:

Day 16.6p

Night 5.73p

Difference = 10.87p

Allowing for 10% losses on battery system

**180days x 1.8kW x 10.87p = £35.21 per year additional saving on users electricity bills**

### Why do I need a PVM-CC-Batt?

Until now there has not been a simple single metering solution which has allowed batteries to charge during off peak tariffs as most standard MID approved generation meters actually measure in both directions. Therefore, any electricity stored directly from the grid would actually pass back through your generation meter and would show as increased generation.

This may sound beneficial as extra revenue could be created, however, the FiT providers would be alerted to the additional generation and would potentially stop paying the FiT payments altogether.

mate have developed The PVM-CC-Batt with special algorithms to simplify the connection of a Hybrid battery PV system, whilst compliantly allowing the batteries to top up their charge via the grid from low rate tariffs, without any risk of losing out on FiT payments.

Fully amendment 3 compliant with built in double pole RCBO, MID approved generation meter and lockable AC isolator, the PVM-CC-Batt is a simple single connection point for all Hybrid Solar Systems.

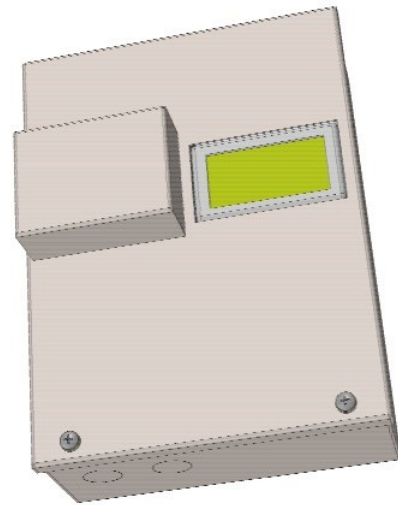

### Product Features

- Simple single connection point for PV installations
- Amendment 3 compliant metal enclosure
- Built in lockable AC isolator
- Double pole PV supply RCBO
- MID approved generation meter
- Designed and built in the UK
- Standard 5 year parts warranty

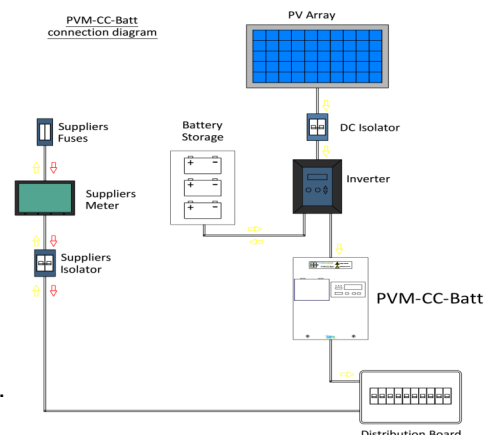

# Dimensions and Specifications

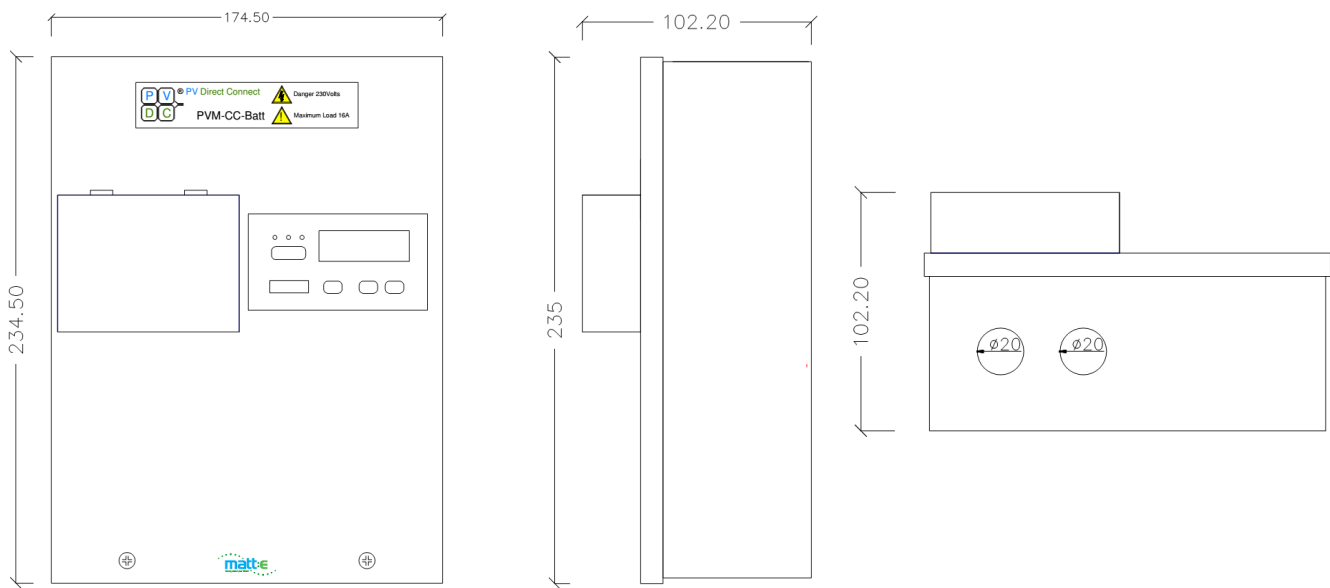

Description	PVDC PVM-CC-Batt connection centre
Input Volts	Nominal input voltage 230V 50Hz, Single Phase AC
Current (Amps)	16 amps
Weight	Approximately 3kg
Operating Temperature	-5°C to +40°C
Terminal Capacity	Incoming Live = 16.0mm <sup>2</sup> Outgoing Live = 6.0mm <sup>2</sup> Incoming Neutral = 16.0mm <sup>2</sup> Outgoing Neutral = 6.0mm <sup>2</sup>
Enclosure	Mild Steel Powder Coated
Ingress Protection	IP20
Warranty	The PVM-CC-Batt connection centre is guaranteed for a period of 5 years from the date of purchase. This warranty is limited to the replacement of faulty components only.

