

# ALPS SERIES

Installation manual



ALPS HY3.6-GL | ALPS HY6.0-GL

V2 | 26/03/24

## 1 Product description

- 1.1 Product description
- 1.2 Safety declarations
- 1.3 Safety instructions

## 2 Installation

- 2.1 Packaging list
- 2.2 Installation instructions
- 2.3 Connection

## 3 Description of LCD display

- 3.1 Basic information view
- 3.2 Parameterisation

## 4 Mode setting

- 4.1 Self-generation and self-use mode (default)
- 4.2 Charge priority mode
- 4.3 Discharge priority mode
- 4.4 AC charge function
- 4.5 Export limit function

## 5 Troubleshooting and maintenance

- 5.1 Troubleshooting based on LCD displays
- 5.2 Fan maintenance

## 6 Datasheet

## 1.1 Product description

The Polar ESS ALPS series models are mainly used for energy storage. That can be the energy stored by solar PV, or energy from the grid.

They can also be used to feed energy to the grid for profit, or as a back-up power source to provide electricity to the user when grid power is lost.

This manual provides product information and installation instructions for ALPS users.

For other detailed information, please refer to <https://polar-ess.co.uk/> or contact our customer service technicians. Note that in the event of content updates, without notice to the user, the latest release version prevails. Please contact our customer service team to obtain.

In the following manual we will refer to the product as ALPS inverter.

The Polar ESS ALPS inverter includes:

- ALPS HY3.6-GL
- ALPS HY6.0-GL

## 1.2 Safety declarations



### CAUTION

The ALPS is designed according to international safety regulations. It has been rigorously tested to ensure its safety and reliability. Please refer to the contents of this manual and the relevant safety information before any operation of the inverter, and strictly observe them during installation and use.

During installation, make sure that the installer has the relevant qualifications and that the installation and use comply with local regulations or standards. Any installation or use of the product that does not comply with the product's safety instructions or regulatory requirements may result in the following problems:

- Result in injury or death to the installer, the user, or a third-party organisation
- Damage or other irreversible effects on the ALPS inverter and other property etc. attributable to the user or third-party organisation

## 1.3 Safety instructions

During the pre-installation/installation/post-installation and subsequent use and maintenance of the inverter, there are safety issues including but not limited to the following. Installers and users are requested to read the following carefully:



### **DANGER** **Dangers of high voltages and large current**

- CAUTION PV HIGH VOLTAGE HAZARD. Avoid electric shock by disconnecting the DC switch on the inverter before and during installation
- CAUTION GRID HIGH VOLTAGE HAZARD. Avoid electric shock by disconnecting the AC switch at the grid connection before and during installation
- CAUTION BATTERY HIGH CURRENT HAZARD. Switch off the battery module before and during installation to avoid electric shock
- Do not disassemble the inverter during inverter operation to avoid electric shock or damage from system operating voltage/current
- Do not operate the inverter when the inverter is running except for the LCD and panel buttons. The rest of the inverter should only be touched when switched off or in other safety situations
- Do not plug or unplug any connection cables (including PV, battery, power grid, communication cables, etc.) during operation
- Ensure that the inverter is reliably earthed and that the operator ensures that they are well protected by reasonably reliable insulation (e.g. personal protective equipment)
- Carefully check at the installation site that the existing wiring is in good condition before installation, operation or maintenance
- Carefully check that the connections between the machine and the PV, battery and grid are in good condition during installation to avoid damage or injury due to poor contact



### **WARNING** **Avoid misoperation and inappropriate usage**

- Installation work for the inverter(system design, installation, operation, setup, configuration and maintenance) must be carried out by qualified personnel as required
- All connections must comply with the relevant local and national standards and regulations
- The inverter and its system may only be connected to the public grid if the public grid allows it
- All warning labels and nameplate cards on the inverter must be clearly visible and not allowed to be removed, obscured or covered
- Installation must be done by selecting the correct and suitable location according to the requirements of this manual, taking into account the safety of the user's subsequent operations
- Ensure that children can't touch or misuse the inverter and its associated systems
- Be aware that most areas of the inverter and its associated systems may be hot during operation. During inverter operation, only the LCD and buttons should be touched



### **NOTE**

- Please read this manual carefully before performing any work on the inverter. After the installation is complete, keep this manual in a safe place so that you can refer to it at any time
- Qualified installers should be trained in the installation and commissioning of electrical systems, and the handling of hazards, and should also have the knowledge to read and understand this manual and other relevant documents. As an installer and operator, it is important to familiarise yourself with local regulations and directives

## 2.1 Packaging list

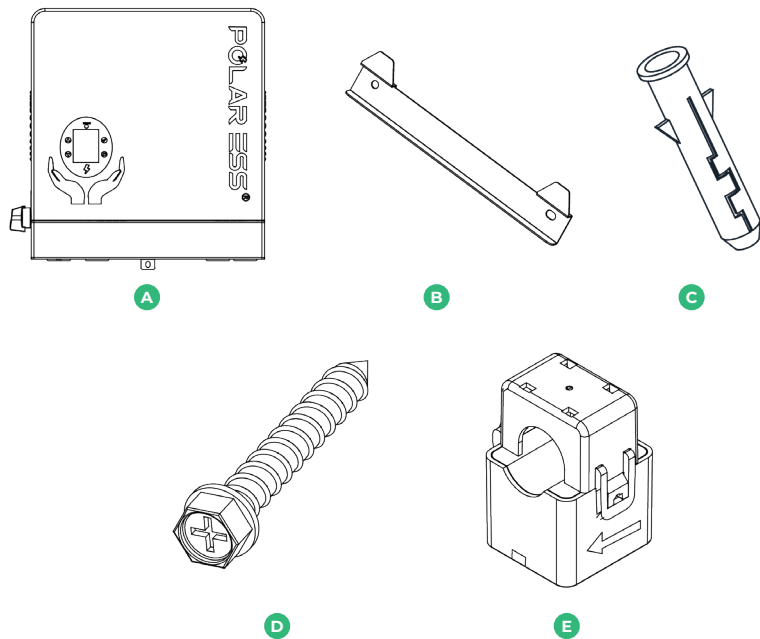

Item	Item name	Quantity
A	POLAR ESS	1
B	Mounting bracket	1
C	Wall plugs	3
D	Mounting frame fixings	3
E	CT	1

## 2.2 Installation instructions

### 2.2.1 Installation position

- Do not install in direct sunlight or near water sources; the inverter must be installed in a dry environment
- The inverter must be installed in an ambient area — the temperature should be below 40° to ensure optimal operation
- The wall where the inverter is mounted must be able to support its weight and dimensions
- Do not install on flammable construction materials
- The humidity of the installation position should be 0-95% and no condensation
- The installation position should be safe
- Do not put anything on the inverter; prevent covering the inverter
- Do not install near TV antenna or another antenna power cable
- The unit must be installed in an easily accessible location. The status display must be visible and not obstructed
- The inverter must be installed vertically with connections always positioned at the bottom; never install horizontally and avoid tilting the unit
- The inverter should ideally be installed indoors, but **must** be dry, the inverter is IP20

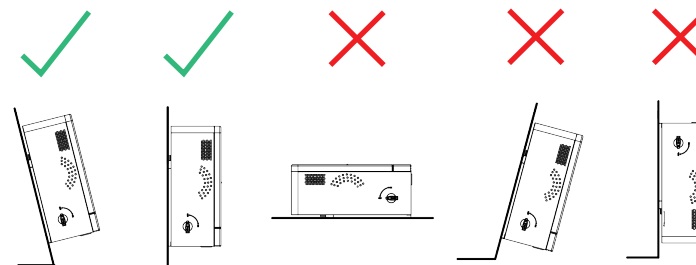

- Observe the minimum clearances to walls, other inverters or objects as shown in the diagram below in order to guarantee sufficient heat dissipation

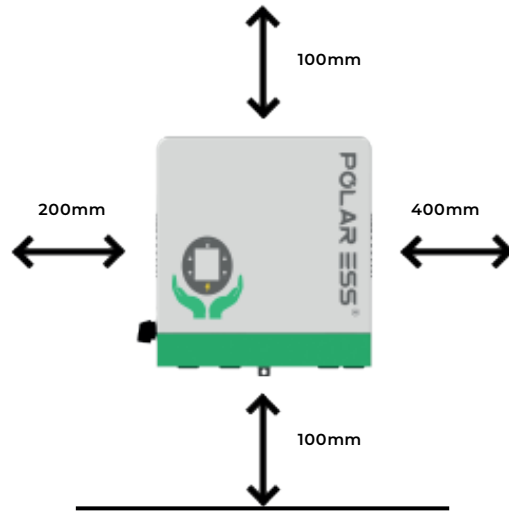

## 2.2.2 Step by step installation

1. The minimum required wall thickness for mounting the inverter is 80mm. Place the wall mounting bracket horizontally onto the wall and mark the position of the bracket holes

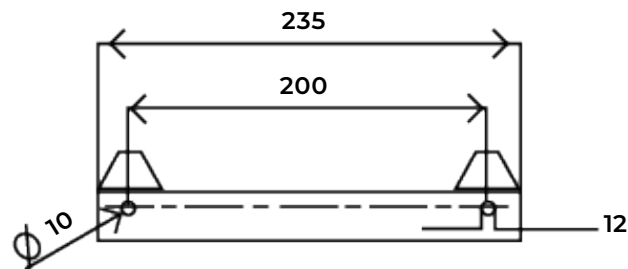

2. Drill 3 holes at the marked positions, at least 55mm deep. Fix the mounting rack to the wall using 3 wall plugs, or other suitable fixings. (E.g., grey/red fischer plugs and M8 coach screws/bolts).

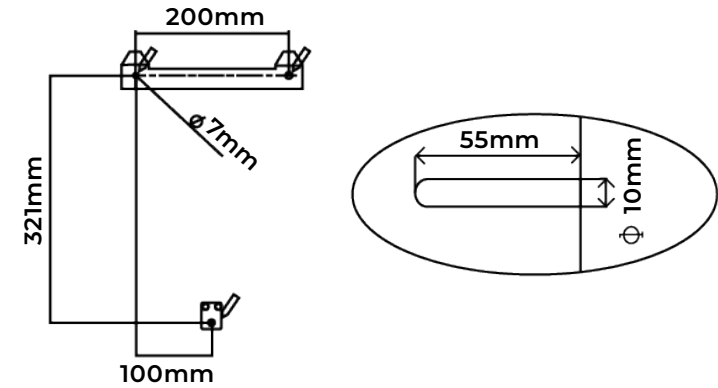

3. Install bracket using 2 fixings

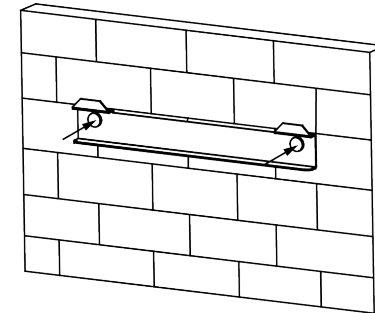

4. Mount the inverter then secure with 1 screw in the bottom bracket

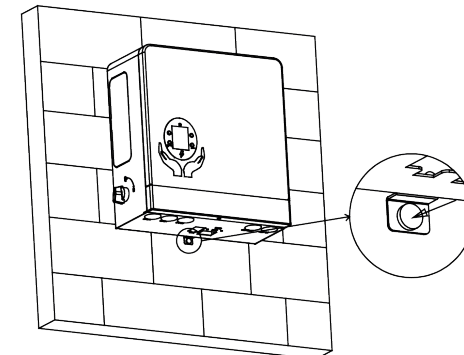

## 2.3 Connection

### 2.3.1 System wiring diagram

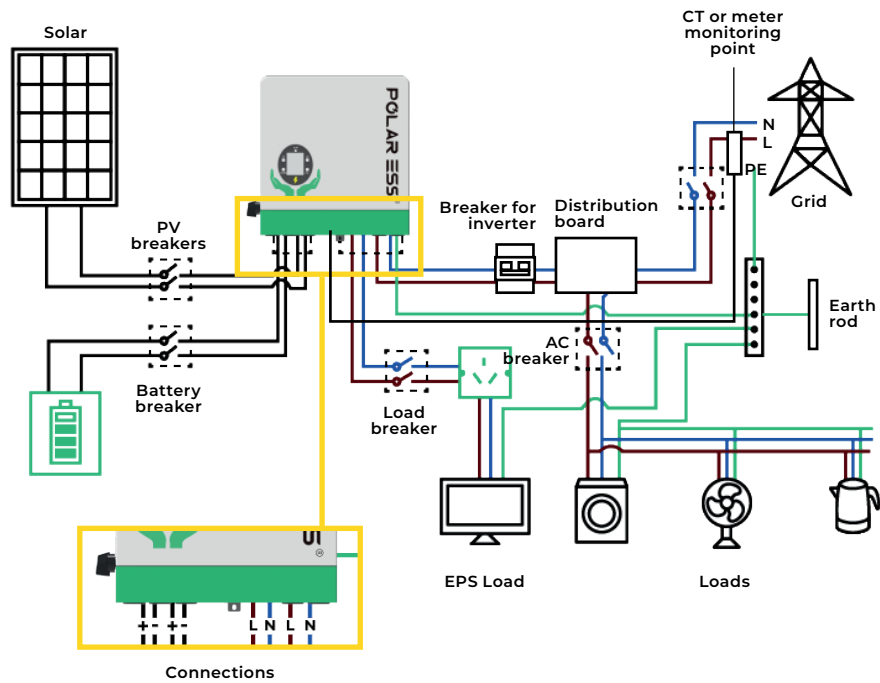

An external AC breaker is needed for on-grid connection to isolate from grid when necessary. Below are the AC breaker requirements. The inverter must be on its own bidirectional TYPEA 30mA RCD device with over-current protection as below

Inverter model	AC breaker specification
ALPS HY3.6-GL	C20
ALPS HY6.0-GL	C32

Please note: if the EPS port load is 6kw-- 9kw, the switch should be 230VAC/63A inverter overview.

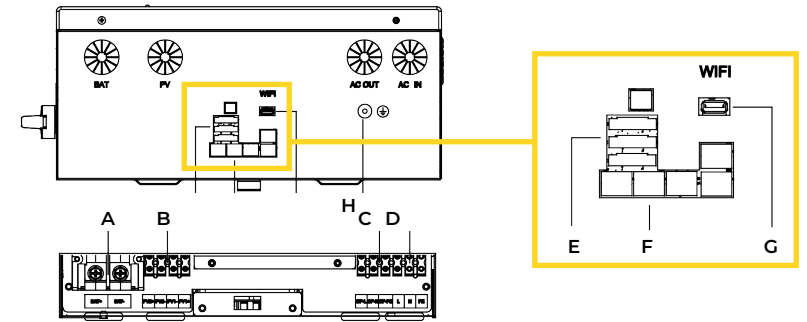

Number	Description
A	Battery terminal
B	PV terminal
C	Backup output terminal
D	AC output terminal
E	Comm port
	RS485/CANBUS
	Meter and CT
F	Digital out/Digital in
	DRM CAN/485 parallel com terminals
G	WiFi terminals
H	Ground terminals

### 2.3.2 PE connection

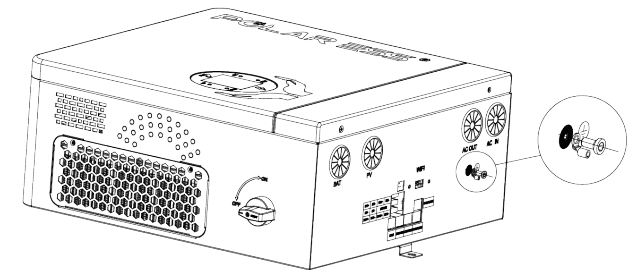

Main earth connection should be connected to the grid tied terminal block.

**Please note:** the earth bond point on the bottom of the inverter is designed for connection to the battery and additional earth bonding.

## 2.3.3 Grid and EPS connection

### 2.3.3.1 On/off-grid load connection

According to the rate power of the inverter, rationally distribute the load on the AC grid side and EPS side. The wirings are as follows:

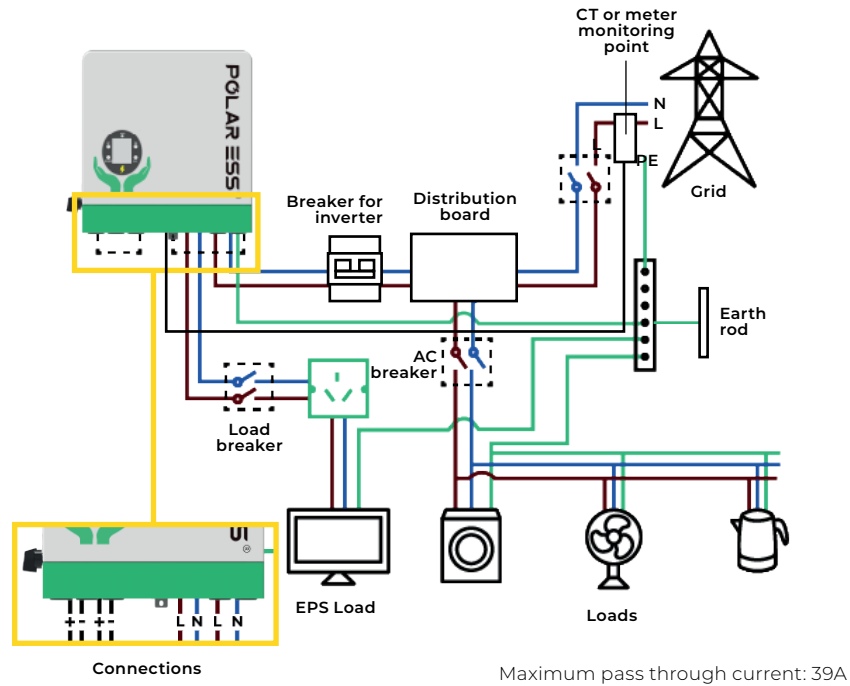

### 2.3.3.2 AC connection

Suggested cable requirement for AC wires:

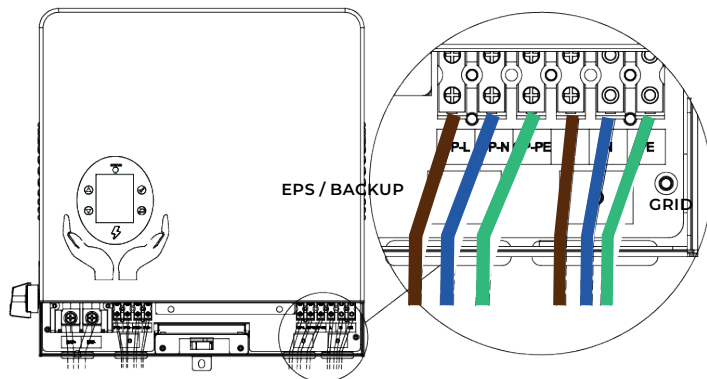

1. Strip 1/4 to 5/16 inch (6-8mm) insulation from one end of the AC/EPS wire
2. Release the screw, pull down and open the lower cover to expose the inner wiring bay, and remove the dust plug from the AC input/output port
3. Use an art knife to cut a hole, pass the AC/EPS wire through the AC input/output holes and insert it into the connecting port of the AC terminal block
4. Tighten the screws on the AC connection terminal block to ensure that the wiring is stable and not loose

### 2.3.3.3 CT/Meter connection

In order to accurately measure the power interaction between the system and the grid, it is necessary to install a CT at the total output port of the system, usually as close to the supplier's meter as possible. Ships with a standard CT.

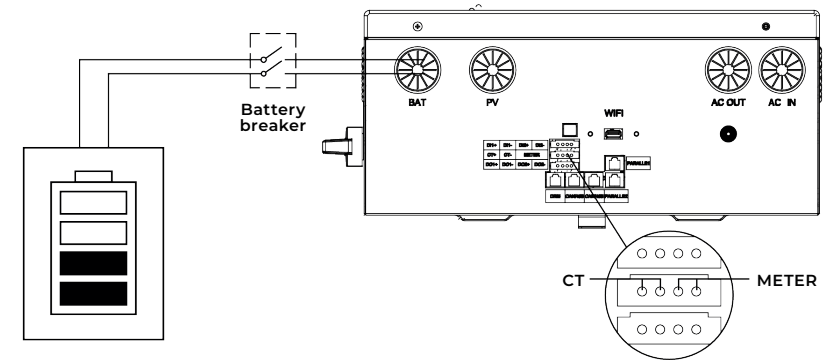

Port	1	2	3	4
CT/Meter	CT+	CT-	METER485+	METER485+

## CT installation diagram

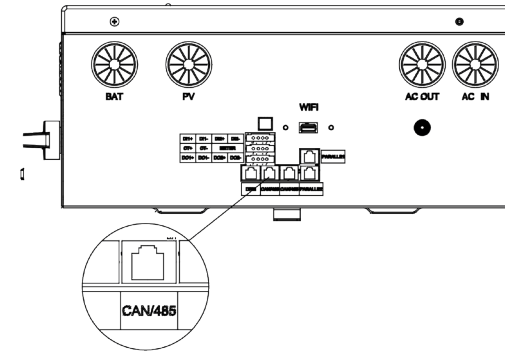
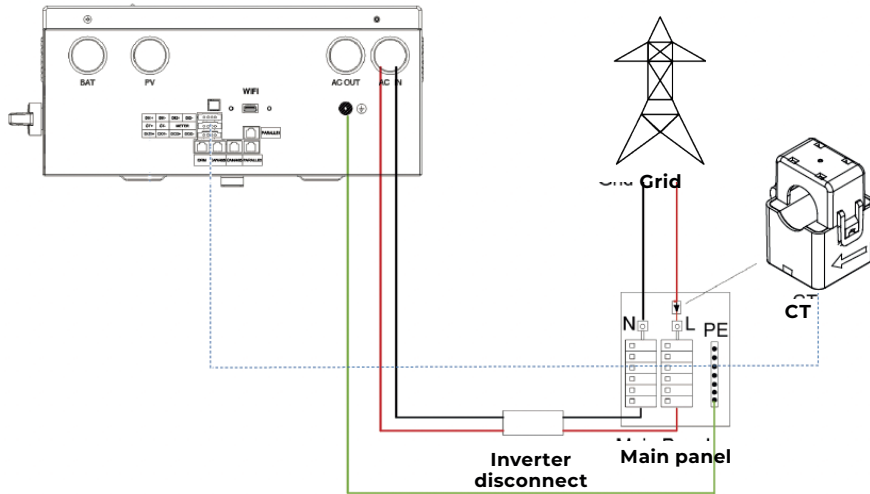

Port	Pin1 orange -white	Pin2 orange	Pin3 green -white	Pin4 blue	Pin5 blue -white	Pin6 green	Pin7 brown -white	Pin8 brown
CAN /RS485	/	/	GND	CANH	CANL	/	RS485+	RS485-

We use the connection of TS568B.

## Meter outlet pin definition:

If customers wish to use meters, they need to purchase them separately, and connect the communication cable directly to the METER port. If the customer needs to prepare the wire separately, please refer to the following definition. We recommend a shielded cable for meter comms. For the correct installation position and installation mode of CT/ electric meter, refer to the above wiring examples. The arrow on the CT must point to the inverter.

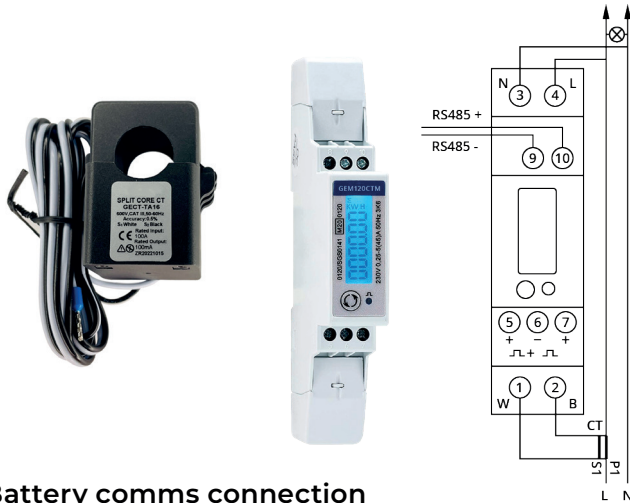

## 2.3.4 Battery comms connection

When the lithium battery is connected to the inverter, the system can run normally only when the battery communication cable is connected to the inverter. The battery communication port is an RJ45 socket, and the related pins are defined as follows. The battery product accessories shipped with the inverter already contain finished wire. If you need to make another wire, please refer to the following pin definition, models currently support CAN and 485 communication.

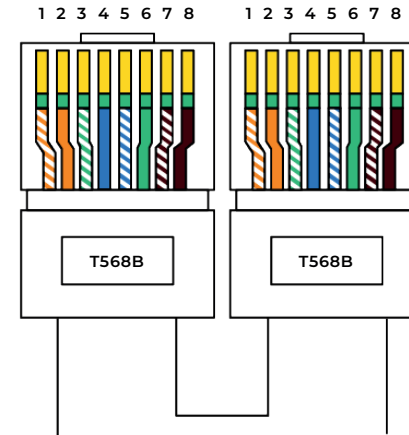

## 2.3.5 PV connection



Please check the minimum ambient temperature of the installation site. The rated Voc on the solar panel nameplate is obtained at 25 °C. Solar panel Voc will increase with the decrease of ambient temperature. Ensure that the maximum solar panel string voltage corrected at the lowest temperature does not exceed the maximum inverter input voltage.

Recommended PV cable:



## NOTE

- Inverter has two independent MPPT, there is one string input per MPPT
- When the customer has only one string, and the current is large, its output line can be connected to two MPPT interfaces, and it can also work normally
- When two PV channels are connected, this will limit the total solar input power to 9KW, and the maximum input power of single MPPT is limited to 4.5KW. When only one PV is connected, this limits the maximum MPPT input power to 6KW
- Follow the wiring annotation underneath the connector block

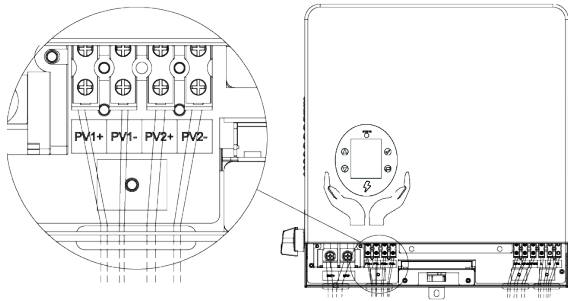

## 2.3.6 Battery connection

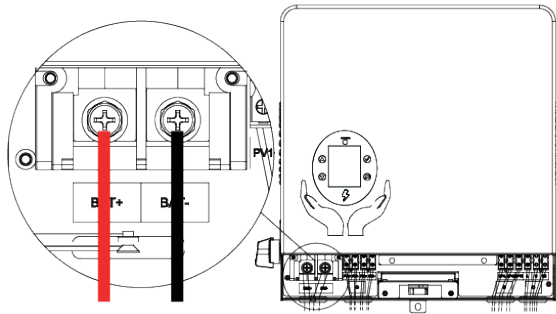

1. Open the lower cover of the inverter to expose the internal wiring bay, and remove the dust plug on the battery input port
2. Strip 1/4 to 5/16 inch (6-8mm) insulation from one end of the battery positive and negative output wires, and crimp the OT terminals (model QT25-8, wire hole 22-25mm<sup>2</sup>, screw hole 8, 4mm) to the wires (mark the OT terminal aperture)
3. Pass the battery wire through the battery input hole, and fix the OT ring on the corresponding terminal block
4. Tighten the screws on the battery connection terminal block to ensure that the wiring is stable and not loose

## 2.3.7 DRMS function

When the inverter is used in Australia, it may need to connect the DRMS device and DRMS terminal of the inverter to run. The RJ45 terminal is defined as followed:

Pin	Pin1 orange -white	Pin2 orange	Pin3 green -white	Pin4 blue	Pin5 blue -white	Pin6 green	Pin7 brown -white	Pin8 brown
DRMS	DRM1/5	DRM2/6	DRM3/7	DRM4/8	Ref/Gen	GND	/	/

### Inverter demand response modes:

MODE	RJ45 pins to be connected	Demand
DRM0	Connect Pin5 and Pin6	Stop
DRM1	Connect Pin1 and Pin5	Disallow charge
DRM2	Connect Pin2 and Pin5	Charge power should be less than 50% of the rated power
DRM3	Connect Pin3 and Pin5	Charge power should be less than 75% of the rated power
DRM4	Connect Pin4 and Pin5	Charge power should be less than 100% of the rated power
DRM5	Connect Pin1 and Pin5	Disallow discharge
DRM6	Connect Pin2 and Pin5	Discharge power should be less than 50% of the rated power
DRM7	Connect Pin3 and Pin5	Discharge power should be less than 75% of the rated power
DRM8	Connect Pin4 and Pin5	Discharge power should be less than 100% of the rated power

DRM1-4 are only effective for charging and does not limit charge power; DRM5-8 are only effective for discharging and does not limit charge power.

## 2.3.8 Data collector connection

### 2.3.8.1 WiFi/4G dongle connection

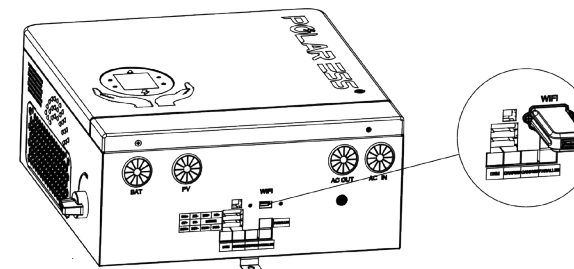

Users can use the WiFi/4G dongle to monitor the inverter, and can remotely view the monitoring data on the mobile app. To use the Polar ESS app on your mobile phone, please download it first and follow the instructions to register an account. 4G dongle connection is the same as the WiFi dongle connection, but check SIM card(s).

# DESCRIPTION OF LCD DISPLAY 3

The inverter is equipped with an LED screen, an LED indicator and 4 function buttons allowing customers to view relevant information and set some functions. The buttons and indicators are described below:

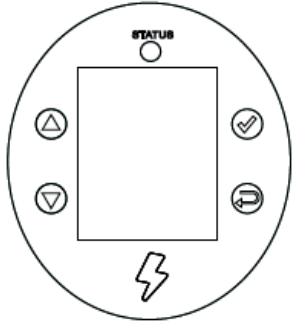

DESCRIPTIONS	CLARIFICATION	
Buttons	For operating the display and setting up the system	
Status indicator	Green light always on	Run normally
	Red light always on	Fault state
	Green light flashing	Standby or bypass state
	Red light flashing	Alarm state
	Red and green lights flash alternatively	Software updating

Containing the grid, PV battery, load power and energy flow, current operating mode and basic.

## 3.1 Basic information view

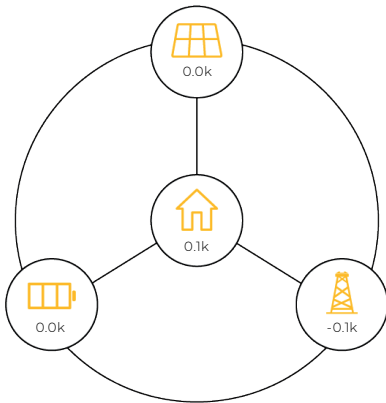

### Main interface:

If the screen is dormant, it can be woken up by pressing any button. The screen will now display the main interface, containing the grid, PV, battery, load power and energy flow, current operating mode and basic status of the inverter.

- Countdown Timer: 0S
- System Mode: Tied Grid
- Inv/Bat Status: Normal / Charge
- Normal

### Main interface:

When the screen wakes up, press the OK button to enter the system menu. You will then see the system information interface. Press the down button to turn down the page. You can view the basic parameters of the system, the current operating state, the history of power generation and other information.

**System Info**

- Model: 6.0K
- Serial Number: AB01234567
- Software version:SD1.0
- Firmware Version: 701
- BAT Serial Number: AB12345678
- BMS FW Version: 4001
- Parallel Type: Master

**Grid Info**

- Grid voltage:230V
- Grid Export Current: 10A
- Grid Frequency: 50Hz
- Grid Active Power: 2300W
- Grid Apparent Power: 2370W

**Inverter Info**

- AC Output Power: 65W
- Output Current: 0.7A
- BU5 voltage:377.1A
- HBUS Voltage:318.9A
- INV Temperature:23.5 °C
- DC Temperature: 24.0 °C

**System Status Info**

- System Status Word1: 0X0000
- System Status Word2: 0X0000
- System Status Word3: 0X0000
- System Status Word4: 0X0000
- System Status Word5: 0X0000
- System Status Word6: 0X0000
- System Status Word7: 0X0000
- System Status Word8: 0X0000
- System Status Word9:0X0000

**Load & Other Info**

- off-Grid Power:1000W
- USB Type: WiFi
- Load Power: 1000W
- Output Voltage: 230.5V
- Output Frequency: 50.00Hz

**PV Info 1**

- PV1 Inter voltage: 300V
- PV1 Inter Current 2A
- PV1 Inter Power: 600W
- PV2 Inter voltage: 300V
- PV2 Inter Current 2A
- PV2 Inter Power: 600W

**PV Info 2**

- PV1 Meter voltage: 230V
- PV1 Meter Current: 3A
- PV1 Meter Power: 690W
- PV2 Meter voltage: 230V
- PV2 Meter Current: 3A
- PV2 Meter Power: 690W

**Battery Info**

- Battery voltage: 53V
- Battery Current: 20A
- Battery Power: 1060W
- Battery Percentage: 56%

**Energy Total Info**

- PV Energy Total: 0.0KWh
- Export Energy Total: 0.0KWh
- Import Energy Total: 0.0KWh
- BTT: 0.0KWh
- Inverter Energy Out Total: 0.0KWh
- AC Charge Energy Total: 0.0KWh

**Energy Today Info**

- PV1 Energy Today: 0.0KWh
- PV2 Energy Today: 0.0KWh
- Export Energy Today: 0.0KWh
- Import Energy Today: 0.0KWh
- Charge Energy Today: 0.0KWh
- Discharge Energy Today: 0.0KWh
- Inverter Energy Out Today: 0.0KWh
- AC Charge Energy Today: 0.0KWh

## 3.2 Parameterisation

With the screen awake, press OK to enter the system menu. Press down to skip the system information screen and find the parameter setting screen.

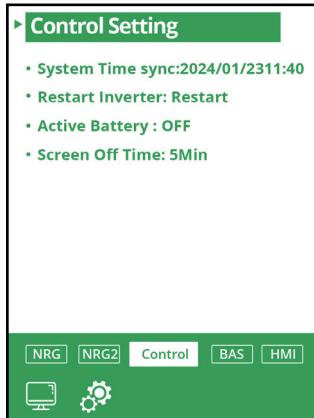

### Control setting:

**System Time Sync:** Calibrates system time, requires internet access

**Enter Restart Inverter:** Restart the inverter. Please note that the power supply may be disconnected during the restart process

**Active Battery:** When enabled, the battery will be activated by power and requires a normal grid and PV connection for using

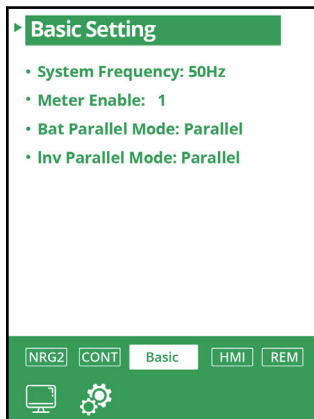

### Basic setting:

**Certification:** Safety regulations for switching ECOs

**System Frequency:** Modify the system grid frequency

**Meter Enable:** When turned on, it will allow the user to connect to a matching smart meter

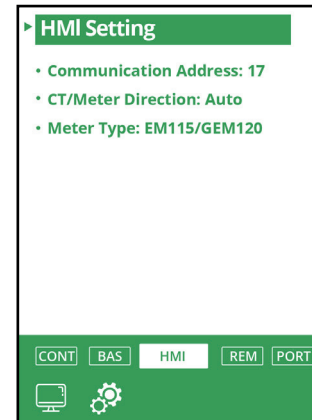

### HMI Setting

**Communication Address:** Modify the external communication address of the accumulator  
**CT/Meter Direction:** Modify the input direction of CT/ meter, used in case the direction of the CT/Meter is reversed

**Meter Type:** Switch the matching meter type

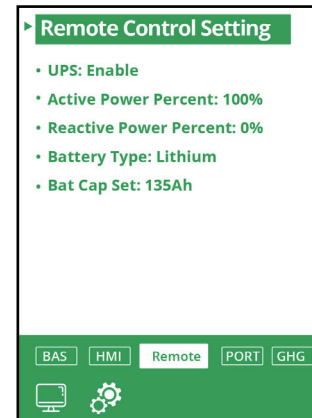

### Remote Control Setting

**UPS:** Switch on/off UPS function

**Active Power Percent:** Set the maximum active power percentage of the output

**Reactive Power Percent:** Setting the maximum output reactive power percentage

**Battery Type:** Switch access to battery types, including lead-acid and lithium batteries

**BAT Cap Set:** Set battery ampere hours, effective for lead-acid batteries

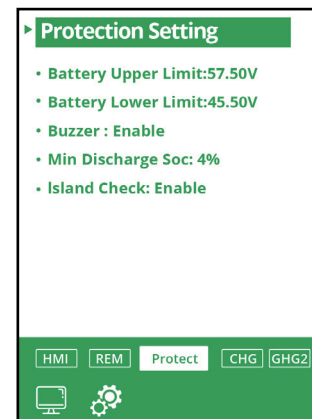

### Protection Setting

**Battery High Limit:** Setting the maximum battery voltage protection value, effective for lead-acid batteries

**Battery Lower Limit:** Setting the minimum battery voltage protection value, effective for lead-acid batteries

**Buzzer:** Switch on/off the buzzer

**Min Discharge SOC:** Set the minimum discharge SOC value of the battery island

**Check:** Enable/disable island checking function

**DC-DC Setting**

- Battery Discharge: Disable
- Battery Charge: Enable
- Self-Use/Eco Mode: Enable
- Export Limit: Enable
- Export Limit Power: 6000W

REM PORT CHG CHG2 GHG3



### DC-DC Setting

Battery Discharge: Enable/disable battery discharge.  
 Battery Charge: Enable/disable battery charge  
 Self-Use: Enable/disable self-generation and self use mode, enabled by default  
 Export Limit: Enable/disable export limit function  
 Export Limit Power: Sets the maximum export limit power value

**Remote Control Setting**

- UPS: Enable
- Active Power Percent: 100%
- Reactive Power Percent: 0%
- Battery Type: Lithium
- Bat Cap Set: 135Ah

BAS HMI Remote PORT GHG



### Power and battery settings

On this page you can set all the generator related settings according to your actual status.

**DC-DC Setting2**

- Charge Start Time 1 : 2 : 00
- charge End Time 1 : 4 :30
- charge sOC1: 100%
- Charge start Time 2: 8 : 00
- charge End Time 2: 9 : 30
- Charge sOC2: 100%
- Charge Start Time3 : 18: 00
- Charge End Time 3 : 19 : 00
- Charge soC3: 100%

PORT CHG CHG2 DCHG



### DC-DC Setting2

Set the time for the inverter to enter the charging priority mode and the charging cut-off SOC value. A total of three time periods can be set.

# MODE SETTING 4

ALPS can be set to different working modes to meet the needs of customers in different application scenarios:

Refer to the WiFi documentation for settings.

## 4.1 Self-generation and self-use mode (default)

In this mode, the priority of load response is photovoltaic > battery > power grid, and the priority of photovoltaic energy flow is load > battery > power grid. Automatic self-use is the factory default mode. This mode is used when the inverter is not in any other mode. You can also manually disable this mode. After this mode is disabled, the battery will no longer respond to the load.

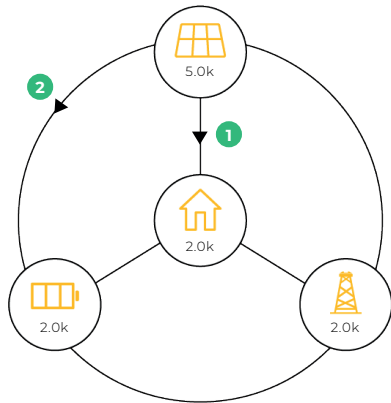

- Countdown Timer: 0S
- System Mode: Tied Grid
- Inv/Bat Status: Normal / Charge
- Normal

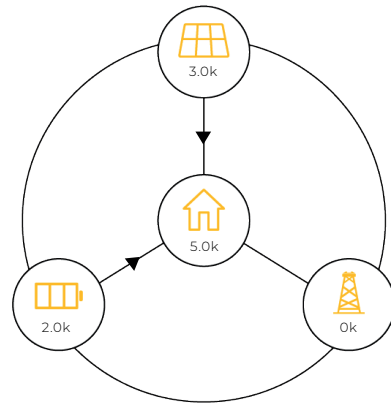

- Countdown Timer: 0S
- System Mode: Tied Grid
- Inv/Bat Status: Normal / Discharge
- Normal

## 4.2 Charge priority mode

In this mode, the energy of the photovoltaic will preferentially charge the battery. Until the power reaches the set SOC, the excess energy will be supplied to the load or fed into the grid, and the battery will not actively discharge. This mode is suitable for frequent power outages, high peak electricity prices, large demand for electricity at night and other scenarios. First store battery energy, and then discharge the load when necessary.

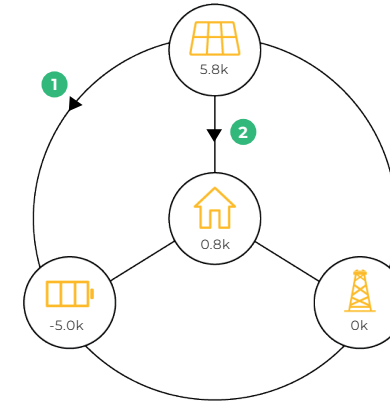

- Countdown Timer: 0S
- System Mode: Tied Grid
- Inv/Bat Status: Normal / Charge
- Normal

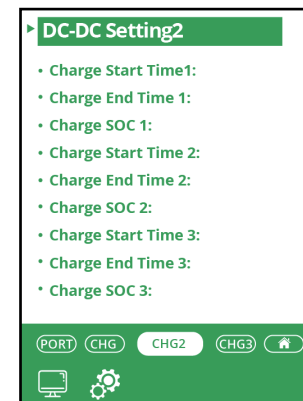

### Settings

Set the required working period and the SOC you want to stop charging, and you can enter the charging priority mode. Automatically cut in and out at the set time period.

## 4.3 Discharge priority mode

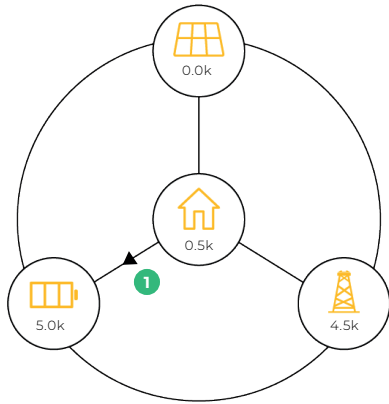

- Countdown Timer: 0S
- System Mode: Tied Grid
- Inv/Bat Status: Normal / Discharge
- Normal

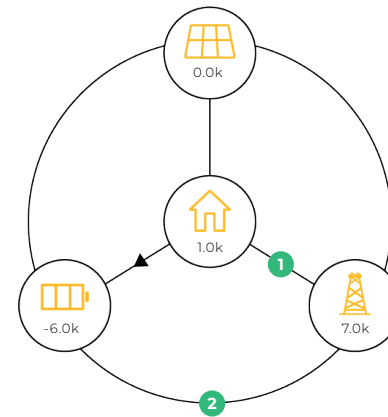
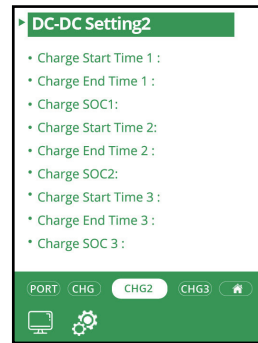
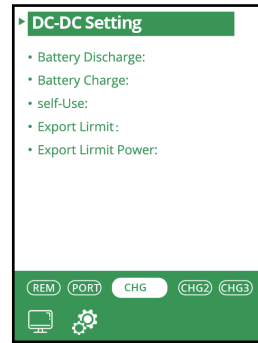

- Countdown Timer: 0S
- System Mode: Tied Grid
- Inv/Bat Status: Normal / Discharge
- Normal

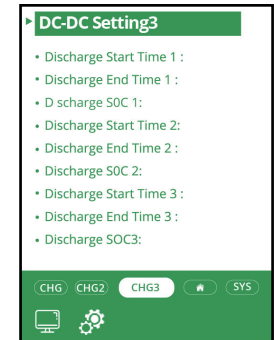
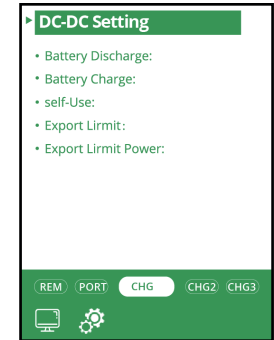

## 4.5 Export limit function

When this feature is enabled, the maximum value of power fed to the grid by the inverter will not exceed the value set by the user. It is suitable for areas where there is an upper limit of grid-connected power requirement.

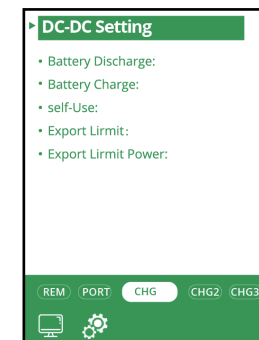

## 4.4 AC charge function

When enabled, the inverter will allow the use of energy from the grid to charge the battery. It is possible to store power for the battery for arbitrage or emergency use.

## 5.1 Troubleshooting based on LCD displays

If your system displays a fault code, please refer to the following troubleshooting guide. If the issue persists, reach out to the Polar ESS support team.

FAULT CODE	DESCRIPTION	TROUBLESHOOTING
DC high	High DC component of output current	Restart the inverter; contact Polar ESS for technical support.
PV isolation low	Low insulation resistance of photovoltaic panels	Check that the connection between the PV panel and the inverter is good. Check that the earth wire of the inverter is well connected.
NTC open	NTC open circuit fault	Switch off the inverter and contact the Polar ESS support team.
Bus voltage high	High bus voltage	Check the PV panel input voltage; whether it is within the rated input voltage range of the inverter. Restart the inverter.
PV voltage high	High PV voltage	Check the PV panel input voltage, whether it is within the rated input voltage range of the inverter.
Boost over temperature	Boost over-temperature	Check that the ambient temperature is within the specifications for use of the inverter.
BuckBoost over temperature	Buckboost over temperature	Check that the ambient temperature is within the specifications for use of the inverter.
INV over temperature	Inverter overheating	Check that the ambient temperature is within the specifications for use of the inverter.
EPS output short fault	Off-grid output short circuit	Check the EPS port loads for damage or shorts. Check the EPS port for damage or the presence of foreign objects.
Init model fault	Utilisation mode exception	Check the inverter mod number.

FAULT CODE	DESCRIPTION	TROUBLESHOOTING
Bus Voltage Unbalance	Positive and negative bus voltage imbalance	Restart the inverter; contact Polar ESS for technical support.
FW Unmatch	M3 and DSP version mismatch	Check that the connection between the PV panel and the inverter is good. Check that the earth wire of the inverter is well connected.
PV1 Short Fault	PV1 short circuit fault	Switch off the inverter and contact Polar ESS customer support.
PV2 Short Fault	PV2 short circuit fault	Check the PV panel input voltage; whether it is within the rated input voltage range of the inverter. Restart the inverter.
NE Detect Fault	Zero ground fault detection	Check the PV panel input voltage, whether it is within the rated input voltage range of the inverter.
Exter Device Faulty	Failure of external equipment	Check that the ambient temperature is within the specifications for use of the inverter.
Internal Com Fault1	Internal communication failure 1	Check that the ambient temperature is within the specifications for use of the inverter.
Internal Com Fault2	Internal communication failure 2	Check that the ambient temperature is within the specifications for use of the inverter.
GFCI High	High leakage current	Check the EPS port loads for damage or shorts; check the EPS port for damage or the presence of foreign objects.
Internal Com Fault3	Internal communication failure 3	Check the inverter mod number.
Internal Over Temp	Inner ring temperature too high	Check that the ambient temperature is within the specifications for the use of the inverter.
Fan Fault	Fan failure	Check for clogged fans; restart the inverter; replace the fan.
Hardware Unmatch	Hardware version mismatch	Restart the inverter.
Meter Comm Loss	Loss of meter communication	Check that the meter is working properly; check that the meter communication cable is connected properly.

## 5.2 Fan maintenance

Please check and clean the fans regularly. The recommended period is 6 months, but may be sooner dependent on the environment. Please check the fan following the below steps. If there is a problem with the fan, turn off the system and wait for more than 5 minutes before disassembling the machine. Isolate the system and then use a vacuum cleaner to remove any dust or debris build up. If this method doesn't clear the blockage then you can use the method below to gain better access to the the heatsink and fans.

1. Remove the fixing screws.



2. Remove the fan. Please note that there is an internal power cable connected.



3. Clean up fan dust and check whether the cable is damaged.

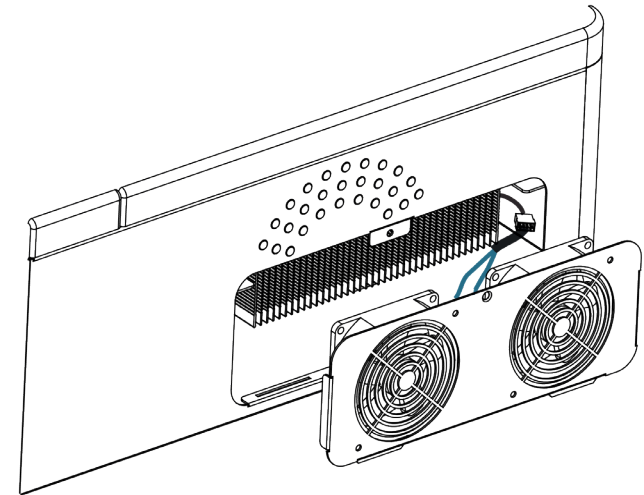

4. If the fan is damaged, remove the fan, replace it with a new one and install it as described above.



Model	ALPS HY3.6-GL	ALPS HY6.0-GL
Max. DC Input Power (W)	5400W	9000W
Start-up Voltage	98V	
Max. PV Voltage	550V	
MPPT Range	90V-500V	
Nominal Voltage	360V	
Max. Short Current	23A/23A	
Max. Input Current	16A/16A	

MPPT Tracker/No. of Strings per MMP Tracker	2/1	
---	-----	--

### Battery

Battery Type	Li-ion	
Battery Voltage Range	42 - 60V	
Nominal Voltage	48V	
Charge/Discharge Current	80A/80A	125A/125A
Max. Battery Charge/Discharge Power (W)	3600W/3600W	6000W/6000W
Communication Interface	CAN	

### Output Data

Nominal AC Output Power	3600W	6000W
Max. Apparent Power Output to Utility Grid (VA)	3600VA	6000VA
Max. Output Current	16VAC	26VAC
Nominal Voltage/Range	230VAC; 184 - 260VAC	
Frequency Range	50+5Hz	
Power Factor (Full Load)	+0.99	
Power Factor Range	0.85 lagging - 0.85 leading	
THDI (Nominal Power)	<3%	

### Backup

Nominal EPS Output Power	3600W	6000W
EPS Peak Power (10s)	5400VA	9000VA
Nominal Voltage	238VAC	
Max. Output Current	23A (peak)	39A (peak)
Nominal Frequency	50Hz	
Automatic Switch Time	<10ms	
THDv (Linear Load)	<3%	

### General

Battery Charge/Discharge Efficiency	94%/94%	
PV Max. Efficiency	97.60%	
Dimensions (W x D x H)	420 x 195 x 475 (mm), 460W (mm) inc. PV Isolator	
IP Grade	IP20	

