



PUZ-WM-VAA

Monobloc Standalone Ultra Quiet Air Source Heat Pumps



The multiple award winning range of Ultra Quiet AA chassis Ecodan monobloc air source heat pumps are designed specifically to suit the demands of the UK market and includes 6.0, 8.5 and 11.2kW sizes.

The innovative, stylish and compact single fan outdoor unit utilises advanced technologies to deliver improved efficiencies. Designed for a wide range of applications, the market leading low noise levels virtually eliminate the need for planning permission, maximises installation options and is a viable solution for all types of domestic requirements that the UK housing market demands.

Key Features

- Self-contained unit, only requiring water and electric connections
- No need for gas supply, flues or ventilation
- Low maintenance and ultra quiet operation
- Operates with outside temperatures as low as -25°C
- Optimised low ambient defrost control and operation down to -7°C
- Hybrid function, for use with conventional boilers
- Energy monitoring as standard
- Multiple unit cascade function



OUTDOOR UNIT		PUZ-WM60VAA(-BS)	PUZ-WM85VAA(-BS)	PUZ-WM112VAA(-BS)
HEAT PUMP SPACE HEATER - 55°C	ErP Rating	A++	A++	A++
	η_s	142%	139%	134%
	SCOP	3.30	3.50	3.45
HEAT PUMP SPACE HEATER - 35°C	ErP Rating	A+++	A+++	A+++
	η_s	190%	193%	191%
	SCOP	4.62	4.57	4.58
HEAT PUMP COMBINATION HEATER - Large Profile ¹	ErP Rating	A+	A+	A+
	η_{wh}	145%	145%	148%
HEATING ² (A-7/W35)	Capacity (kW)	6.0	8.5	11.2
	Power Input (kW)	1.88	3.27	3.73
	COP	3.20	2.60	3.00
OPERATING AMBIENT TEMPERATURE (°C DB)		-20 ~ +35	-20 ~ +35	-25 ~ +35
SOUND DATA ³	Pressure Level at 1m (dBA)	45	45	45
	Power Level (dBA) ⁴	58	58	60
WATER DATA	Pipework Size (mm)	22	28	28
	Flow Rate (l/min)	17	24	32
	Water Pressure Drop (kPa)	8.0	15.0	24.0
	DIMENSIONS (mm)			
WEIGHT (kg)	Width	1050	1050	1050
	Depth	480	480	480
	Height	1020	1020	1020
ELECTRICAL DATA	WEIGHT (kg)	98	98	119
	Electrical Supply	220-240v, 50Hz	220-240v, 50Hz	220-240v, 50Hz
	Phase	Single	Single	Single
	Nominal Running Current [MAX] (A) ⁵	5.68 [13]	9.1 [22]	10.9 [28]
REFRIGERANT CHARGE (kg) / CO ₂ EQUIVALENT (t)	Fuse Rating - MCB Sizes (A) ⁶	16	25	32
	R32 (GWP 675)	2.2 / 1.49	2.2 / 1.49	3.0 / 2.03

¹ Combination with E-PT20X Cylinder
² Under normal heating conditions at outdoor temp: -7°CDB / -8°CWB, outlet water temp 35°C, inlet water temp 30°C.
³ Under normal heating conditions at outdoor temp: 7°CDB / 6°CWB, outlet water temp 55°C, inlet water temp 47°C as tested to BS EN14511.
⁴ Sound power level tested to BS EN12102.
⁵ Under normal heating conditions at outdoor temp: 7°C, outlet water temp: 35°C.
⁶ MCB Sizes BS EN60898-2 & BS EN60947-2.

η_s is the seasonal space heating energy efficiency (SSHEE) η_{wh} is the water heating energy efficiency



Certificate Number: 037-0033-20 / 037-0034-20
 Product Type: Heat Pumps
 Product Reference: PUZ-WM60/85VAA(-BS) / PUZ-WM112VAA(-BS)

Front View

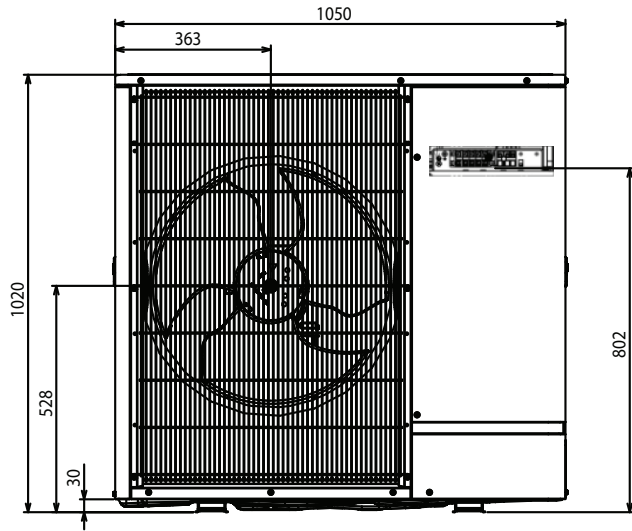

Upper View

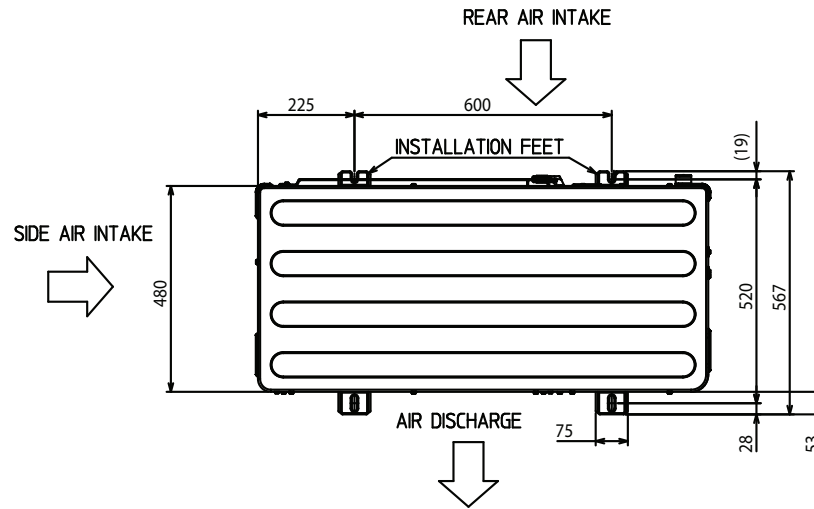

Side View

