



# Installation & Operation Manual



Download  
Manual



Growatt New Energy

**Shenzhen Growatt New Energy Co., Ltd**  
4-13/F, Building A, Sino-German (Europe) Industrial Park,  
Hangcheng Ave, Bao'an District, Shenzhen, China  
**T** +86 0755 2747 1942  
**E** service@ginverter.com  
**W** www.ginverter.com

GR-UM-298-A-00

# Contents

## 1 Information on this manual

- 1.1 Validity
- 1.2 Target Group
- 1.3 Additional information
- 1.4 Symbols in this document
- 1.5 Glossary

## 2 Safety

- 2.1 Intended Use
- 2.2 Qualification of skilled persons
- 2.3 Safety instructions
- 2.4 Assembly Warnings
- 2.5 Electrical Connection Warnings
- 2.6 Operation Warnings

## 3 Product introduction

- 3.1 TL-X2 Overview
- 3.2 Type label
- 3.3 Dimensions and weight
- 3.4 Storage of the Inverter
- 3.5 Advantages of the unit

## 4 Unpacking and inspection

## 5 Installation

- 5.1 Safety instructions
- 5.2 Selecting the installation location
- 5.3 Mounting the Inverter

## 6 Electrical connection

- 6.1 Safety
- 6.2 Wiring AC output
- 6.3 Connecting the second protective conductor
- 6.4 Connecting the PV array (DC input)
- 6.5 Connecting signal cables
- 6.6 Grounding the inverter
- 6.7 Active power control with a smart meter , CT or ripple control signal receiver
- 6.8 Inverter demand response modes (DRMS)
- 6.9 AFCI (Optional)

## 7 Commissioning

- 7.1 Starting the inverter
- 7.2 General settings
- 7.3 Advanced settings
- 7.4 Communications

## 8 Powering on/off the inverter

- 8.1 Powering on the inverter
- 8.2 Powering off the Inverter

## 9 Maintenance and Cleaning

- 9.1 Checking the heat dissipation
- 9.2 Cleaning the Inverter
- 9.3 Checking the DC disconnect

## 10 EU Declaration of Conformity

## 11 Troubleshooting

- 11.1 Error messages displayed on OLED
- 11.2 System faults
- 11.3 Inverter warnings
- 11.4 Inverter faults

## 12 Warranty

## 13 Decommissioning

- 13.1 Dismantling the inverter
- 13.2 Packing the inverter
- 13.3 Storing the inverter
- 13.4 Disposing of the inverter

## 14 Technical Data

- 14.1 Specifications
- 14.2 DC & AC connector info
- 14.3 Torque
- 14.4 Accessories

## 15 Compliance Certificates

## 16 Contact

# 1 Information on this manual

## 1.1 Validity

This manual provides instructions for assembling, installing, commissioning, and maintaining the following Growatt Inverter models:

MIC 600TL-X2  
 MIC 750TL-X2  
 MIC 800TL-X2  
 MIC 1000TL-X2  
 MIC 1500TL-X2  
 MIC 2000TL-X2  
 MIC 2500TL-X2  
 MIC 3000TL-X2  
 MIC 3300TL-X2

This manual does not cover information about the equipment connected to the MIC TL-X2, such as PV modules. You can find information about the connected equipment from the manufacturer of that particular equipment.

## 1.2 Target Group

This manual is intended for qualified personnel who have received professional training and have the necessary skills and knowledge in the construction and operation of this device. Qualified Personnel are trained to deal with the potential dangers and hazards associated with installing electric devices.



## 1.3 Additional information



Find further information on specific topics in the download area at [www.ginverter.com](http://www.ginverter.com). This manual and other related documents must be stored in an easily accessible location and ensure that they are available at all times when needed. Growatt assumes no liability for any damage caused by failure to observe these instructions. The information in this document is subject to change without notice.

## 1.4 Symbols in this document











### 1.4.1 Warnings in this document

A warning indicates a potential hazard that could cause device damage or personal injury and calls for extra attention to a specific procedure or practice. Failure to follow operating instructions can result in partial or complete destruction of the Growatt equipment and other connected equipment, as well as the risk of personal injury.

Symbol	description
 DANGER	<b>DANGER</b> indicates a hazardous situation which, if not avoided, will result in death or serious injury.
 WARNING	<b>WARNING</b> indicates a hazardous situation which, if not avoided, could result in death or serious injury.

 CAUTION	<b>CAUTION</b> indicates a hazardous situation which, if not avoided, could result in minor or moderate injury.
 NOTICE	<b>NOTICE</b> is used to address practices not related to personal injury.
 Information	<b>Information</b> that you must read and know to ensure optimal operation of the system.

### 1.4.2 Markings on this product

Symbol	Explanation
	Danger! High voltage!
	Risk of fire!
	Danger! Burn warning!
	Delayed discharge: High voltage exists after the battery is powered off. It takes 5 minutes for the battery to discharge to the safe voltage.
	Grounding: indicates the position for connecting the PE cable
	Direct Current (DC)
	Alternating Current (AC)
	Refer to the manual
	CE mark. The inverter complies with the requirements of the applicable CE guidelines.
	The inverter must not be disposed of with the household waste.

## 1.5 Glossary

**AC**  
Abbreviation for "Alternating Current"

**DC**  
Abbreviation for "Direct Current"

**Energy**  
Energy is measured in Wh (watt hours), kWh (kilowatt hours) or MWh (megawatt hours). The energy is the power calculated over time. For example, your inverter operates at a constant power of 4600 W for half an hour and then at a constant power of 2300 W for another half an hour, it has fed 3450Wh of energy into the power distribution grid within that hour.

**Power**  
Power is measured in W (watts), kW (kilowatts) or MW (megawatts). Power is an instantaneous value. It displays the power your inverter is currently feeding into the power distribution grid.

**Power rate**  
Power rate is the ratio of current power feeding into the power distribution grid and the maximum power of the inverter that can feed into the power distribution grid.

**Power factor**  
Power factor is the ratio of true power or watts to apparent power or volt amps. They are identical only when current and voltage are in phase than the power factor is 1.0. The power in an ac circuit is very seldom equal to the direct product of the volts and amperes. In order to find the power of a single phase ac circuit the product of volts and amperes must be multiplied by the power factor.

**PV**  
Abbreviation for photovoltaic.

**Wireless communication**  
The external wireless communication technology is a radio technology that allows the inverter and other communication products to communicate with each other. The external wireless communication does not require line of sight between the devices and it is selective purchasing.

## 2.1 Intended Use

The unit converts the DC power generated by the photovoltaic (PV) modules into grid-compliant AC power and feed it into the utility grid as single-phase power. All of the MIC-TLX2 series inverters, including the MIC 600TL-X2, MIC 750TL-X2, MIC800TL-X2, MIC 1000TL-X2, MIC 1500TL-X2, MIC 2000TL-X2, MIC 2500TL-X2, MIC 3000TL-X2, and MIC 3300TL-X2 models, are designed in strict adherence to all necessary safety regulations. However, improper use of the inverters may cause serious hazards for the operators and other individuals or cause device damage and property damage.

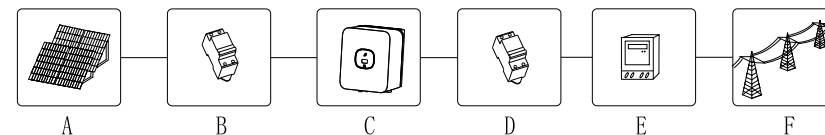

Position	Description
A	PV modules
B	DC load circuit breaker
C	Inverter
D	AC load circuit breaker
E	Energy meter
F	Utility grid

The inverter may only be operated with a permanent connection to the public power grid. The inverter is not intended for mobile use. Any use of the product other than that described in the Intended Use section does not qualify as the intended use. The manufacturer/supplier is not liable for damage caused by such unintended use, and the operator assumes all risks associated with it.

### PV modules Capacitive Discharge Currents

PV modules with large capacities relative to earth, such as thin-film PV modules with cells on a metallic substrate, may only be used if their coupling capacity does not exceed 1uF. During feed-in operation, a leakage current flows from the cells to earth, the magnitude of which depends on the installation method (e.g. foil on metal roof) and weather conditions (e.g., rain or snow). This "normal" leakage current may not exceed 50mA due to the fact that the inverter would otherwise automatically disconnect from the electricity grid as a protective measure.



## 2.2 Qualification of skilled person

The MIC TL-X2 grid-tied inverter system can only function properly when connected correctly to the AC distribution network. Before connecting the inverter to the power distribution grid, you need to obtain approval from the local utility company. Only qualified and trained technical personnel are allowed to perform the electrical connection.

## 2.3 Safety instructions

The MIC TL-X2 series inverters are designed and tested in compliance with international safety standards, including IEC62109-1, CE, VDE0126-1-1, AS4777, and others. However, it is still important to observe all the safety precautions during installation and operation of the inverter. Read through and follow all instructions, cautions, and warnings provided in this manual. If you have any questions, please contact Growatt's technical services at +86 (0)755 2747 1942.

## 2.4 Assembly Warnings



 <p><b>WARNING</b></p>	<ul style="list-style-type: none"> <li>➤ Before installing the unit, inspect it for transport or handling damage that could compromise insulation integrity or safety clearances. Failure to do so may result in safety hazards.</li> <li>➤ Assemble the inverter as per the instructions in this manual. Determine the installation position with care and adhere to specified cooling requirements.</li> <li>➤ Unauthorized removal of necessary protections, improper use, incorrect installation and operation may lead to serious safety and shock hazards and/or equipment damage.</li> <li>➤ In order to minimize the potential of a shock hazard due to hazardous voltages, cover the entire solar array with dark material prior to connecting the array to any equipment.</li> </ul>
 <p><b>CAUTION</b></p>	<ul style="list-style-type: none"> <li>➤ Grounding the PV modules: As the MIC TL-X2 is a transformerless inverter, it has no galvanic separation. Do not ground the DC circuits of the PV modules connected to the MIC TL-X2. Only ground the mounting frame of the PV modules. If you connect grounded PV modules to the MIC TL-X2, it may result in an error message indicating "PV ISO Low".</li> <li>➤ Comply with the local requirements for grounding the PV modules and the PV generator. GROWATT recommends connecting the generator frame and other electrically conductive surfaces in a way that ensures continuous conduction with ground, which helps to provide optimal protection for the system and personnel.</li> </ul>

## 2.5 Electrical Connection Warnings

 <p><b>DANGER</b></p>	<ul style="list-style-type: none"> <li>➤ The components in the inverter are energized. Touching these components can result in serious injury or death.             <ul style="list-style-type: none"> <li>• Only qualified and trained technicians can open the inverter.</li> <li>• Only qualified and trained personnel can perform installation, maintenance and replacement.</li> <li>• Do not touch damaged inverters.</li> </ul> </li> <li>➤ Caution! The high voltage of the inverter can lead to severe personal injury.             <ul style="list-style-type: none"> <li>• The system takes 20 minutes to fully discharge after it is powered off.</li> </ul> </li> <li>➤ Persons with limited physical or mental abilities may only work with the Growatt inverter following proper instruction and under constant supervision. Children are forbidden to play with the Growatt inverter. Ensure that the inverter is not accessible to Children.</li> </ul>
----------------------------------------------------------------------------------------------------------	---------------------------------------------------------------------------------------------------------------------------------------------------------------------------------------------------------------------------------------------------------------------------------------------------------------------------------------------------------------------------------------------------------------------------------------------------------------------------------------------------------------------------------------------------------------------------------------------------------------------------------------------------------------------------------------------------------------------------------------------------------------------------------------------------------------------------------------------------------------------------------------------------------------------------------------------------------------------------

 <p><b>WARNING</b></p>	<ul style="list-style-type: none"> <li>➤ All electrical connections, such as conductor termination, fuses, and PE connection, must be performed in accordance with the prevailing regulations. When performing any operations on the inverter while it is powered on, it is important to adhere to all safety regulations to minimize the risk of accidents.</li> <li>➤ Systems with inverters typically need additional control devices such as switches and disconnects, as well as protective devices like circuit breakers and fuses. The specific type of control and protective devices needed will depend on the relevant safety regulations in effect.</li> </ul>
-----------------------------------------------------------------------------------------------------------	---------------------------------------------------------------------------------------------------------------------------------------------------------------------------------------------------------------------------------------------------------------------------------------------------------------------------------------------------------------------------------------------------------------------------------------------------------------------------------------------------------------------------------------------------------------------------------------------------------------------------------------------------------------------------

## 2.6 Operation Warnings

 <p><b>WARNING</b></p>	<ul style="list-style-type: none"> <li>➤ Ensure all connectors are properly sealed and secured during operation.</li> <li>➤ Although designed to meet all safety requirements, some parts and surfaces of the inverter are extremely hot during operation. For safety reasons, avoid contact with the heat sink at the back of the PV Inverter or nearby surfaces while the inverter is operating.</li> <li>➤ Incorrect sizing of the PV plant may result in high DC voltages that could damage the inverter. In such cases, the inverter display will show the error message "PV voltage High!"</li> <li>➤ Turn the rotary switch of the DC disconnect to the Off position immediately.</li> <li>➤ Contact the installer.</li> </ul>
 <p><b>CAUTION</b></p>	<ul style="list-style-type: none"> <li>➤ All operations regarding transportation, installation, start-up and maintenance must be performed by qualified and well-trained personnel, and in compliance with all prevailing codes and regulations.</li> <li>➤ After the system powers off, take great caution as the remaining charge may still cause electrical shocks; to minimize the risk of accidents and damage, follow all safety symbols and markings on the unit and in this manual.</li> <li>➤ Although standardized emission limit values are in place to minimize interference, certain situations may still result in interference for the specified application area. This can happen when sensitive equipment is located near the setup location, or when the setup location is near radio or television receivers. In these cases, the operator is responsible for taking appropriate measures to resolve the issue.</li> <li>➤ Keep a safe distance of at least 20cm from the inverter at all times.</li> </ul>

# 3 Product description

## 3.1 MIC TL-X2 Overview

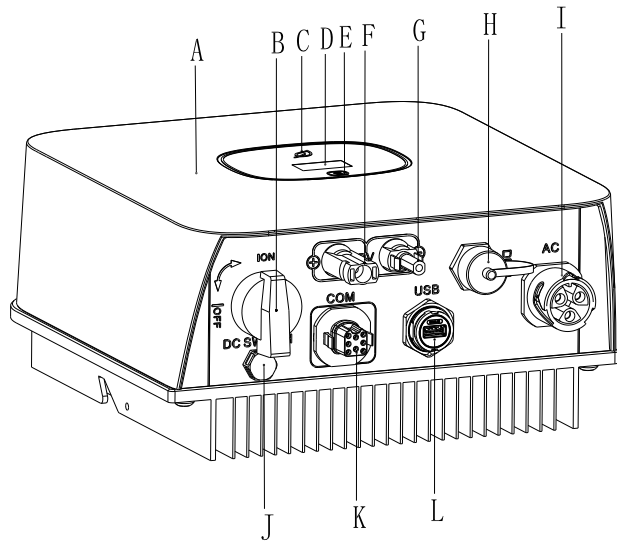

Position	Description
A	COVER
B	DC SWITCH
C	LED
D	OLED
E	TOUCH BUTTON
F	PV INPUT +
G	PV INPUT -
H	DRM PORT
I	AC OUTPUT
J	VENTILATION VALVE
K	COM PORT
L	USB PORT

### Symbol on the inverter

Symbol	Description	Explanation
	Touch symbol	Touch button. You can switch the OLED display and set parameter by touching.
	Inverter status symbol	Indicates inverter operation status: Red: Fault. Green: Normal. Red leaf flashing: Warning or DSP Programming. Green leaf flashing: M3 Programming.

### 3.2 Type label

The type labels provide a unique identification of the inverter, including the device type, device-specific characteristics, certificates and approvals). The type labels are on the left side of the enclosure.

 PV Grid Inverter	
<b>Model name</b>	MIC 3000TL-X2
<b>Max. PV voltage</b>	550 d.c.V
<b>PV voltage range</b>	50-550 d.c.V
<b>PV Isc</b>	24 d.c.A
<b>Max. input current</b>	16 d.c.A
<b>Max. output power</b>	3000 W
<b>Max. apparent power</b>	3000 VA
<b>Nominal output voltage</b>	230 a.c.V
<b>Max. output current</b>	14.3 a.c.A
<b>Nominal output frequency</b>	50/60 Hz
<b>Power factor range</b>	0.8leading~0.8lagging
<b>Safety level</b>	Class I
<b>Ingress protection</b>	IP66
<b>Operation ambient temperature</b>	-30°C - +60°C
VDE0126-1-1 	
x <span style="float: right;">Made in China</span>	

More details about the type label are shown in the chart below:

Model Name	MIC 600 TL-X2	MIC 750 TL-X2	MIC 800 TL-X2	MIC 1000 TL-X2	MIC 1500 TL-X2
Max. input voltage	500V				
Max. input current	16A				
Start voltage	50V				
MPP voltage range	50V~500V				
AC nominal voltage	230V				
AC grid frequency	50/60 Hz				
Max. apparent power	600VA	750VA	800VA	1000VA	1500VA
Max. output current	2.9A	3.6A	3.8A	4.8A	7.1A
Power factor	0.8leading...0.8lagging				
Environmental Protection Rating	IP66				
Operation Ambient temperature	-30...+60°C (-22...+ 140°F) performance de-rate may be initiated above 45°C ( 113°F)				

Model Name	MIC 2000 TL-X2	MIC 2500 TL-X2	MIC 3000 TL-X2	MIC 3300 TL-X2
Max. input voltage	500V	550V	550V	550V
Max. input current	16A			
Start voltage	50V			
MPP voltage range	50V-500V	50V-550V	50V-550V	50V-550V
AC nominal voltage	230V			
AC grid frequency	50/60 Hz			
Max. apparent power	2000VA	2500VA	3000VA	3300VA
Max. output current	9.5A	11.9A	14.3A	14.3A
Power factor	0.8leading...0.8lagging			
Environmental Protection Rating	IP66			
Operation Ambient temperature	-30...+60°C (-22...+ 140°F) performance de-rate may be initiated above 45°C ( 113°F)			

### 3.3 Dimensions and weight

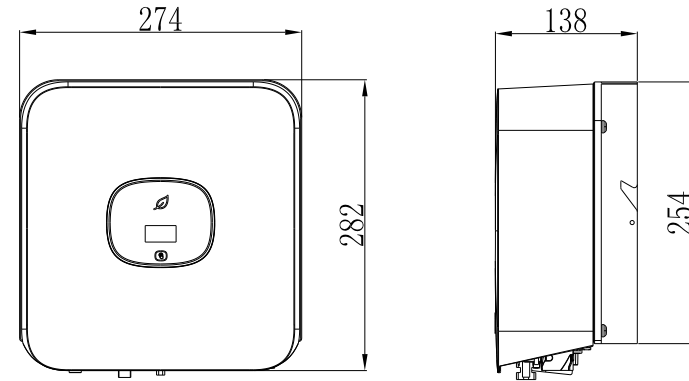

Model	Height (H)	Width (W)	Depth (D)	Weight
MIC 600-2000 TL-X2	282mm 11.1inch	274mm 10.78inch	138mm 5.4inch	6.0kg
MIC 2500-3300 TL-X2				6.2kg

### 3.4 Storage of the Inverter

If you want to store the inverter in your warehouse, you should choose an appropriate location.

- The unit must be stored in the original package with the desiccant left inside.
- Keep the storage temperature at -30°C to +60°C with a relative humidity up to 100%.
- If storing multiple inverters, ensure the carton does not exceed ten layers.
- After long-term storage, a local installer or the service department of GROWATT should perform a comprehensive test before installation.

### 3.5 Advantages of the unit

- Maximum efficiency of 97.6%
- Wide input voltage range: 50-550Vdc
- Reactive power regulation
- Integrated DC switch
- DSP controller
- Touch control
- Multi active power control mode
- Easy installation

# 4 Unpacking and inspection

Before delivery, every inverter undergoes rigorous testing and inspection to ensure proper electrical and mechanical functioning. We take great care in packaging our inverters to ensure safe transportation, but it is possible for transport damage to occur. In such cases, the responsibility falls on the shipping company. Inspect the inverter and the package thoroughly and immediately notify the responsible shipping company if any damage is found. We are available to provide assistance if needed. When transporting the inverter, it is recommended to use the original or equivalent packaging and ensure that the carton does not exceed four layers for safe transport.

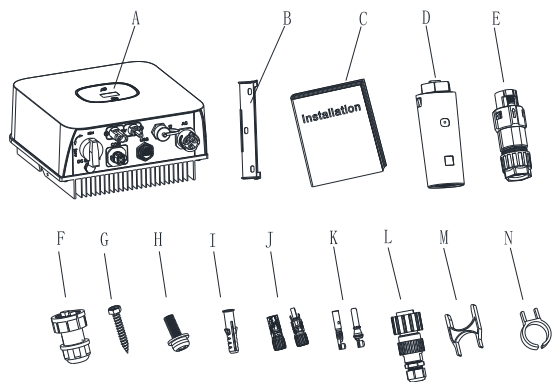

After unpacking the inverter, check that the contents are intact and complete. The package should contain the inverter and the accessories listed below. Please check all of the accessories carefully in the carton. If anything is missing, contact your dealer at once.



Object	Description	Quantity
A	Inverter	1
B	Mounting bracket	1
C	Quick Guide	1
D	Monitor(Optional)	1
E	Signal connector	1
F	DRM PORT (Australia or EU)	1
G	Self-tapping screws	3
H	Safety-lock screws	2
I	Plastic expansion pipe	3
J	PV+/PV- terminal	1/1
K	PV+/PV- metal terminal	1/1
L	AC connector	1
M	Uninstall signal and AC connector tool	1
N	Uninstall PV tool(except Australia)	1

# Installation 5

## 5.1 Safety instructions

	<p><b>Risk of fire.</b> Although electrical devices are carefully constructed, they still have the potential to cause fires. Do not install the inverter near flammable materials.</p>
	<p><b>Burn warning.</b> The running inverter generates high temperature on the shell. Mount the inverter in a way that prevents accidental contact.</p>
	<p><b>Exposure to radiation can cause damage to health.</b></p> <ul style="list-style-type: none"> <li>➤ Despite maintaining standardized emission limit values, interference may occur in certain application areas, particularly when sensitive equipment is located nearby. In such cases, operators must take proper action to address the situation.</li> <li>➤ Never install the inverter near the sensitive equipment (e.g. radios, telephones, televisions, etc.)</li> <li>➤ Keep a distance of at least 20 cm from the inverter at all time.</li> <li>➤ Growatt assumes no responsibility for compliance to EMC regulations for the entire system</li> </ul>

- All electrical installations must comply with the local and national electrical codes. Do not remove the casing of the inverter. The inverter contains no user serviceable parts. Any servicing or repairs should be referred to qualified service personnel. All wiring and electrical installation should be conducted by qualified service personnel.
- Handle the unit with care while unpacking it and check for any external damage. If any damage is found, contact your local dealer.
- Ensure that the inverters are properly grounded to protect property and personal safety.
- The inverter must only be operated with the PV generator. Do not connect any other source of energy to it.
- Disconnect the AC and DC voltage sources inside the PV inverter before performing any maintenance or servicing of the equipment.
- This unit is designed to feed power to the public power grid (utility) only. Do not connect this unit to an AC source or generator. Connecting the inverter to external devices could result in serious damage to your equipment.
- The photovoltaic panel generates DC voltage when exposed to light, which is then used to charge the DC link capacitors when connected to this equipment.
- The energy stored in the DC link capacitors of this equipment poses a risk of electric shock. High voltages may still exist inside the PV inverter even after the unit is disconnected from the grid and photovoltaic panels. For safety reasons, do not remove the casing until at least 5 minutes after disconnecting all power sources.
- Although designed to meet all safety requirements, some parts and surfaces of the inverter can become extremely hot during operation. For safety reasons, avoid contact with the heat sinks at the back of the PV-Inverter or nearby surfaces while the inverter is operating.

## 5.2 Selecting the installation location

- This section provides guidance for determining a proper installation position to avoid device damage and personal injury.
- Select an installation position that can support the weight and dimensions of the inverter.
- Install the inverter in an appropriate place for the user's ease to view and operate on the display.
- Do not install the inverter on structures constructed of inflammable or thermolabile materials.
- Install the inverter in a well-ventilated place and keep it free from dust.
- The inverter is protected to IP66 and can be installed indoors and outdoors.
- The humidity of the installation location should be between 0~100% without condensation.
- Select a position that permits easy access for later maintenance or repair.
- Install the inverter vertically or at a maximum back tilt of 15 degrees. Do not install the inverter at a front tilt, side tilt, horizontally, or upside down.

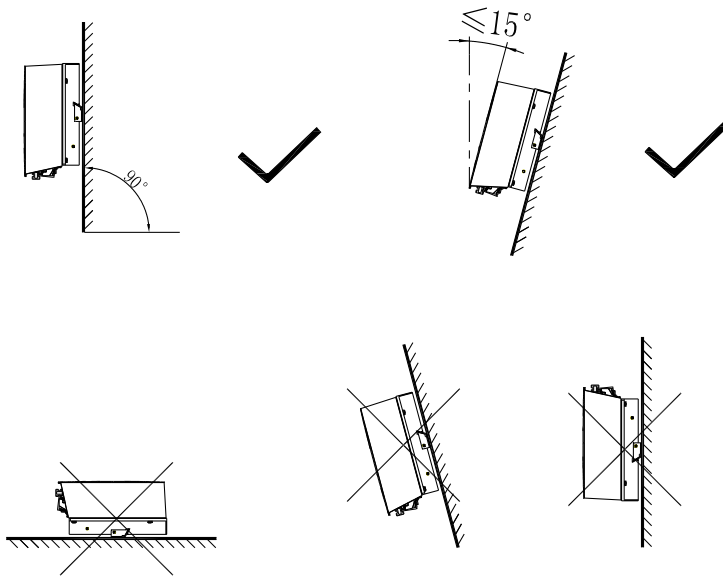

- Ensure that the inverter is not accessible to children.
- Do not put any things on the inverter. Do not cover the inverter.
- Do not install the inverter near television antenna or any other antennas and antenna cables.
- Install the inverter in a well-ventilated place to ensure heat dissipation and keep the ambient temperature below 40°C to achieve optimal performance.
- Do not expose the inverter to direct sunlight, as performance de-rate may be initiated due to additional temperature rise.
- Reserve enough clearance around the inverter as shown below:

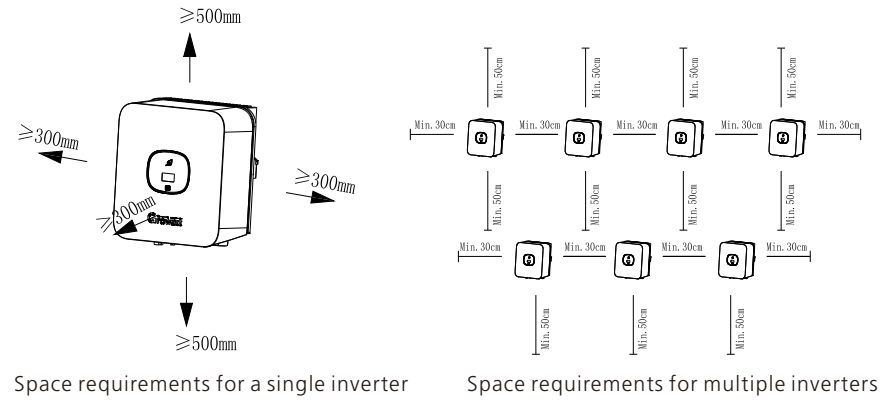

- Ensure that there is enough space between each inverter to prevent the cooling air of the neighboring inverter from being drawn in.
- If necessary, increase the clearance spaces between the inverters and ensure adequate fresh air supply to guarantee optimal cooling of the inverters.

Protect the inverter against direct sunlight, rain and snow. Install the inverter in a sheltered place or install an awning over the inverter.

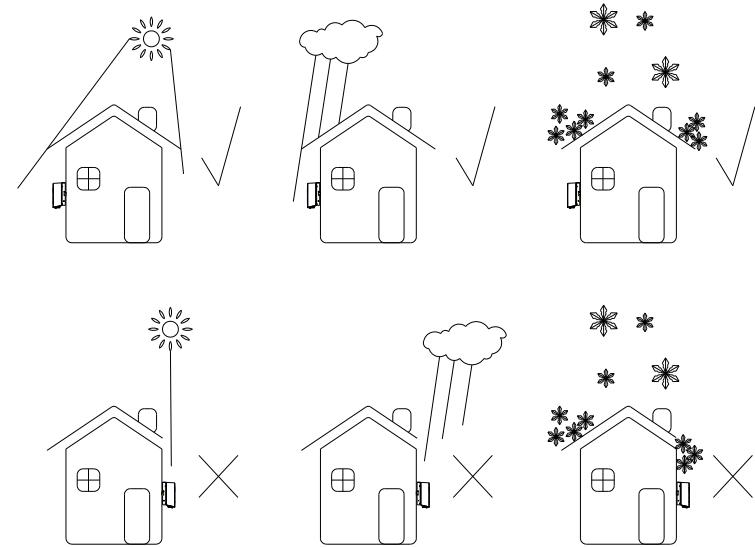

- Do not install the inverter in a sealed enclosure.

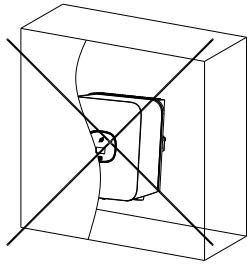

## 5.3 Mounting the Inverter

### 5.3.1 Mounting the Inverter with a bracket



**DANGER**

For safety reasons, avoid the water pipes and power cables buried in the wall when drilling holes.

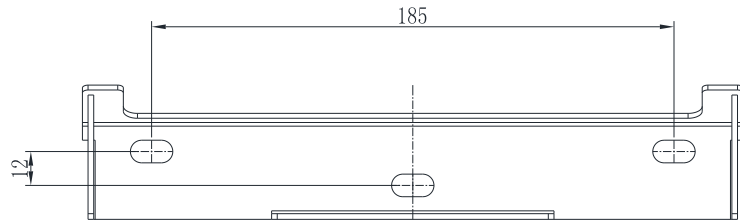

- Fix the mounting bracket as the figure shows. Do not make the screws to be flush to the wall. Instead, leave 2 to 4mm of the screw exposed.

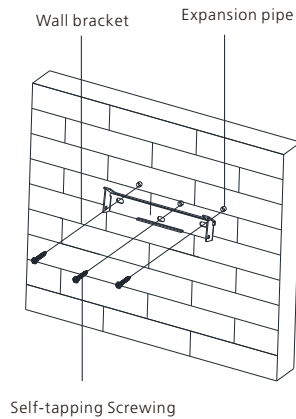

### 5.3.2 Wall-mounting the inverter



**WARNING**

To prevent personal injury caused by a falling inverter, ensure that the bracket is securely installed before mounting the inverter onto the mounting bracket.

- Lift the inverter slightly higher than the bracket. Keep balance when moving the inverter, considering the weight of it.

Fix the inverter onto the bracket using the match hooks on the bracket.

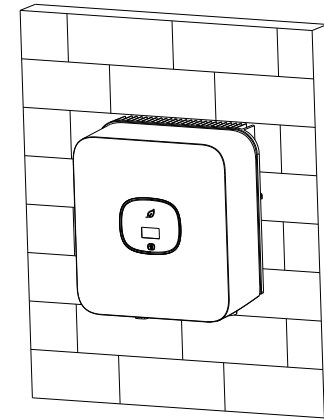

- After confirming that the inverter is securely fixed onto the bracket, firmly tighten the M4 safety locking screws.

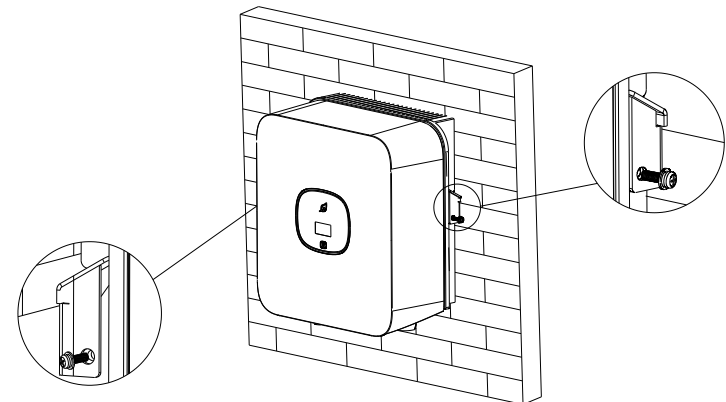



# 6 Electrical connection

Decisive Voltage Class (DVC) indicated for ports

Port	Class
AC	C
DC	C
DRM	A
RS485&USB	A

## 6.1 Safety

	<b>Danger! High Voltage!</b> High voltages may cause electric shocks result in serious injury, death or serious property damage from inverter in operation. Before performing any operations on the inverter, ensure that the AC and DC switches on the inverter are OFF.
 <b>WARNING</b>	Risk of damaging electronic components due to electrostatic discharge. Take appropriate ESD precautions when replacing and installing the inverter.

## 6.2 Wiring AC Output

 <b>WARNING</b>	<ul style="list-style-type: none"> <li>You must install a separate single-phase circuit breaker or other load disconnection unit for each inverter in order to ensure that the inverter can be safely disconnected under load.</li> </ul> <p><b>NOTE :</b> The inverter has the function of detecting residual current and protecting the inverter against residual current. If you want to install an AC breaker which supports residual current detection, ensure that the rating residual current of the AC breaker is greater than 300mA.</p>
-----------------------------------------------------------------------------------------------------	-------------------------------------------------------------------------------------------------------------------------------------------------------------------------------------------------------------------------------------------------------------------------------------------------------------------------------------------------------------------------------------------------------------------------------------------------------------------------------------------------------------------------------------------------------

For the AC breaker rating current, please refer to the table below:

MIC 600TL-X2	5A/230V
MIC 750TL-X2	5A/230V
MIC 800TL-X2	5A/230V
MIC 1000TL-X2	10A/230V
MIC 1500TL-X2	10A/230V
MIC 2000TL-X2	16A/230V
MIC 2500TL-X2	16A/230V
MIC 3000TL-X2	16A/230V
MIC 3300TL-X2	16A/230V

## The AC wiring steps:

1. Uninstall the parts of the AC connection plugs in the accessory bag.

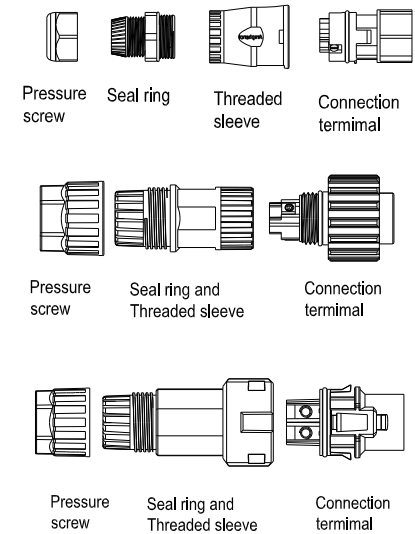

2. Route the exposed core wires through the pressure screw, seal ring and the threaded sleeve in sequence. Insert the cables into the connection terminals and ensure the correct polarity. Pull the cable back to ensure that it is securely connected.

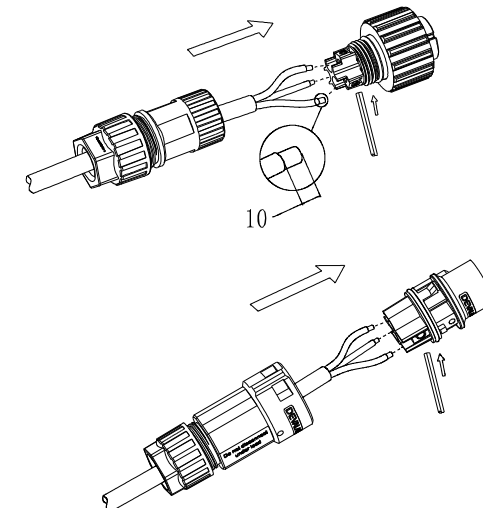

3. Push the threaded sleeve into the socket. Tighten the cap on the terminal.

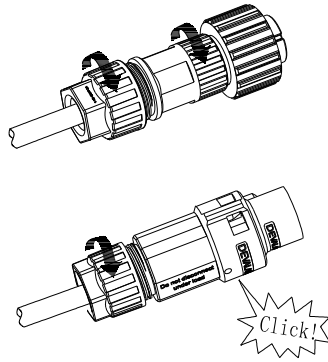

4. Finally, push or screw the threaded sleeve to the connection terminal until both are locked tightly on the inverter.

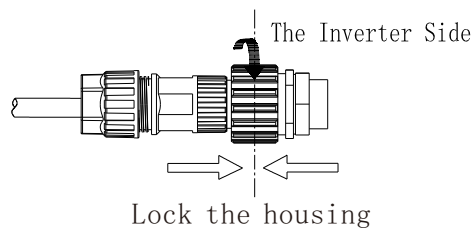
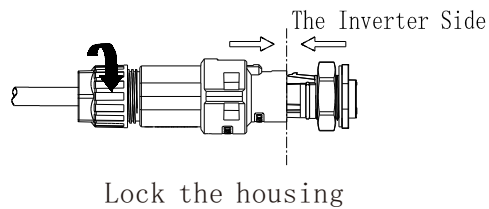
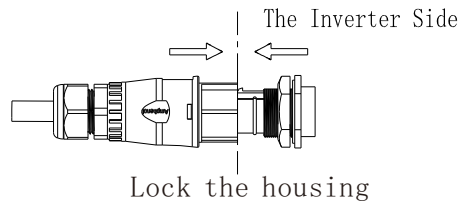

5. To remove the AC connector, press the bayonet out of the slot with a small screw driver and pull it out, or unscrew the threaded sleeve and then pull it out.

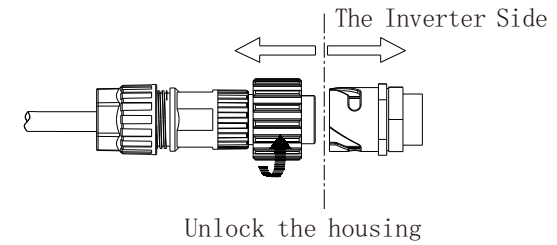
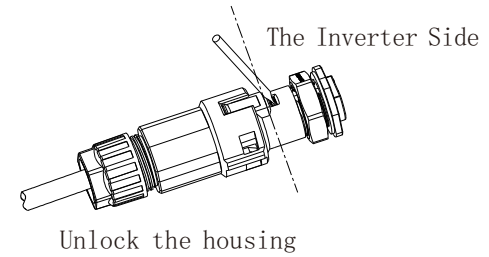

Recommended cable specifications

Conductor cross-sectional area & outer diameter	Max. cable length				
	MIC 600TL-X2	MIC 750TL-X2	MIC 800TL-X2	MIC 1000TL-X2	MIC 1500TL-X2
2 mm <sup>2</sup> 14AWG	92m	72m	68m	54m	37m
3.3 mm <sup>2</sup> 12AWG	150m	120m	113m	90m	61m
Conductor cross-sectional area & outer diameter	Max. cable length				
	MIC 2000TL-X2	MIC 2500TL-X2	MIC 3000TL-X2	MIC 3300TL-X2	
3.3 mm <sup>2</sup> 12AWG	45m	36m	30m	27m	
5.2 mm <sup>2</sup> 10AWG	73m	58m	48m	44m	

### 6.3 Connecting the second protective conductor

In some installation countries, a second protective conductor is required to prevent touch current in the event of a malfunction in the original protective conductor. For installation countries falling within the scope of validity of the IEC standard 62109, you must install the protective conductor on the AC terminal with a conductor cross-section of at least 10 mm<sup>2</sup>Cu. Alternatively, you can install a second protective conductor on the earth terminal with the same cross-section as the original protective conductor on the AC terminal. This prevents touch current in the event of a malfunction in the original protective conductor.

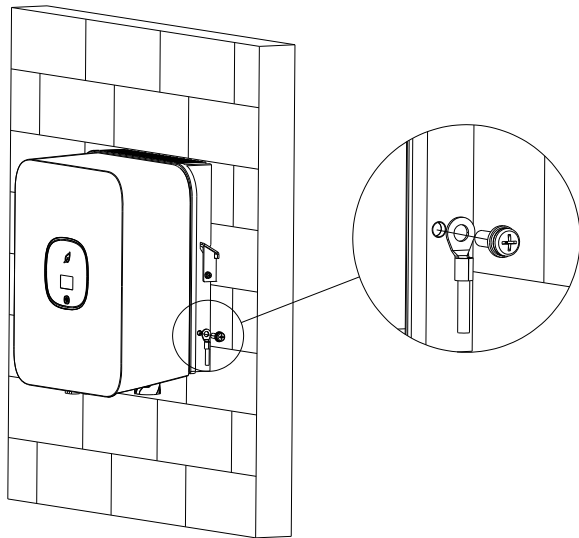

### 6.4 Connecting the PV Array (DC input)

#### 6.4.1 Conditions for DC Connection

 <b>WARNING</b>	<p>The solar modules connected to the inverter must conform to the Class A requirements of the IEC 61730 standard. Please use the same brand male and female PV connectors.</p>
--------------------	---------------------------------------------------------------------------------------------------------------------------------------------------------------------------------

The MIC TL-X2 single-phase inverter has only one independent PV input. Please note that the connectors are paired (male and female connectors). The connectors for PV arrays and inverters are VP-D4 connectors.

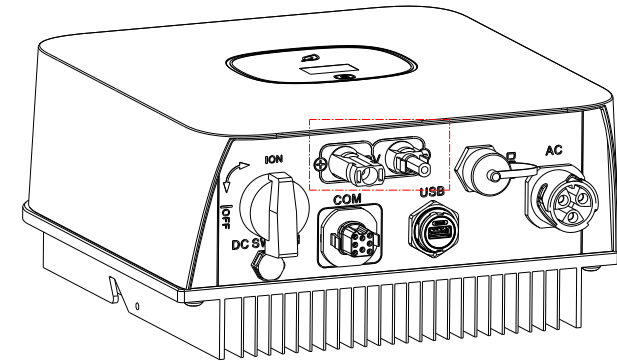

 <b>CAUTION</b>	<p>If the inverter is not equipped with a DC switch but it is mandatory in the country of installation, you must install an external DC switch. The following limit values of the DC input of the inverter must not be exceeded:</p> <table border="1"> <thead> <tr> <th>Model</th> <th>PV Max. current</th> <th>Max. voltage</th> </tr> </thead> <tbody> <tr> <td>MIC 600-2000TL-X2</td> <td>16A</td> <td>500V</td> </tr> <tr> <td>MIC 2500-3300TL-X2</td> <td>16A</td> <td>550V</td> </tr> </tbody> </table>	Model	PV Max. current	Max. voltage	MIC 600-2000TL-X2	16A	500V	MIC 2500-3300TL-X2	16A	550V
Model	PV Max. current	Max. voltage								
MIC 600-2000TL-X2	16A	500V								
MIC 2500-3300TL-X2	16A	550V								

#### 6.4.2 Connecting the PV Array (DC input)

 <b>DANGER</b>	<p><b>Danger! High voltage!</b>            Before connecting the PV array, cover the PV array with light screens to prevent exposure to light. Make sure that the DC switch and AC breaker are disconnected from the inverter. NEVER connect or disconnect the DC connectors under load. Make sure the maximum open circuit voltage (VOC) of each PV string is not greater than the maximum input voltage of the inverter. Check the design of the PV plant. The Max. open circuit voltage, which can occur at solar panels temperature of -10°C, must not exceed the Max. input voltage of the inverter.</p>
 <b>WARNING</b>	<p>Improper operation during the wiring process can cause fatal injury to operators or irreparable damage to the inverter. Only qualified personnel can perform the wiring work. Do not connect the positive or negative pole of the PV array to the ground, which would cause serious damage to the inverter. Before connecting the PV modules, check the connection cables for correct polarity and make sure that the maximum input voltage is within the specified range.</p>

### Connection of PV terminals

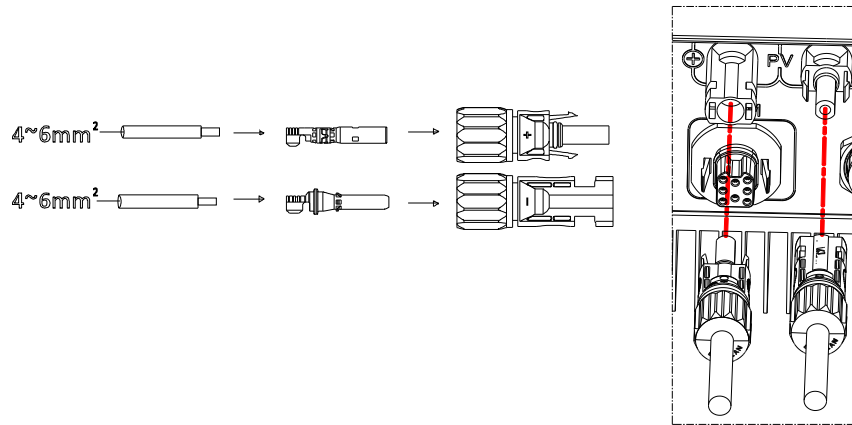

**Step 2** Push the threaded sleeve into the socket. Tighten the cap on the terminal.

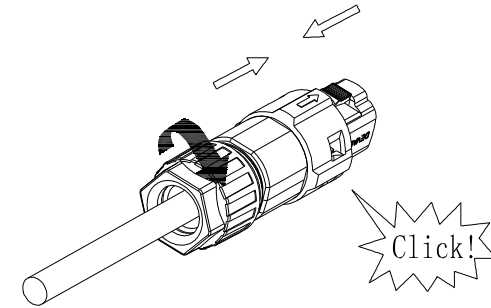

## 6.5 Connecting signal cables

This series of inverters are equipped with an 8-pin signal connector. Signal Cable Ports:

NO.	Definition	NO.	Definition	
1	N/A	5	CT-P	Signal for export limitation (Optional)
2	N/A			
3	RS485A1	7	RS485A2	Signal for Smart meter
4	RS485B1			
		8	RS485B2	

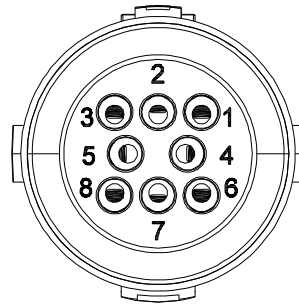

**Step 3** Push the threaded sleeve to the connection terminal until both are locked tightly on the inverter.

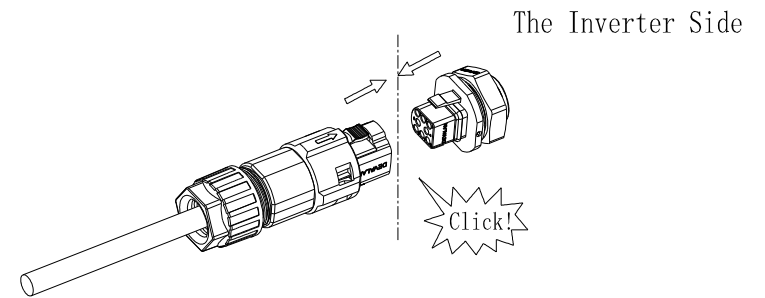

### Procedure

**Step 1** Route the exposed core wires through the pressure screw, seal ring and the threaded sleeve in sequence. Insert the cables into the connection terminals following the numbers indicated on them. Pull the cable back to ensure that it is securely connected.

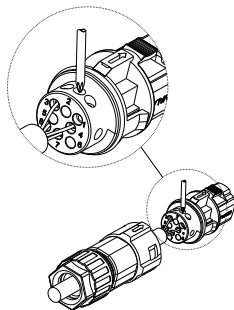

### Uninstall the signal connector

**Step 1** Press down on the fasteners and gently pull it out from the inverter.

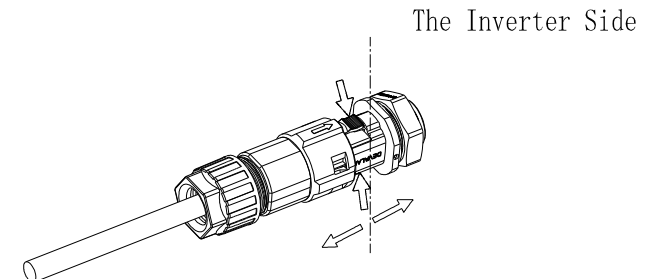

**Step 2** Insert the H type tool and pull it out from the socket.

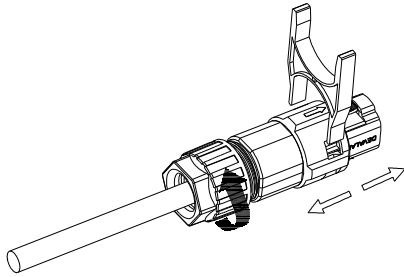

## 6.6 Grounding the inverter

The inverter must be connected to the AC grounding conductor of the power distribution grid via the ground terminal (PE).

 <b>WARNING</b>	<p>Due to the transformerless design, it is not allowed to ground the DC positive and negative poles of the PV array.</p>
--------------------	---------------------------------------------------------------------------------------------------------------------------

## 6.7 Active power control with a smart meter, CT (Optional) or ripple control signal receiver

 <b>Information</b>	<p>The export limitation CT or meter must be installed between the inverter and the load/grid.</p>
------------------------	----------------------------------------------------------------------------------------------------

The inverter of this series has an integrated export limitation function. To enable this function, you can connect a smart meter or a CT (optional). The recommended smart meter model is Eastron SDM230-Modbus. The recommended CT model is TOP 90-S10/SP4 (LEM). The primary aperture is 10mm and the recommended output cable length is 5m. When installing the CT, ensure that the arrow on the CT is pointing towards the inverter.

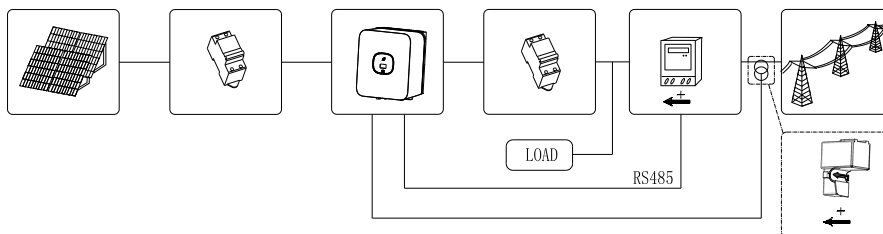

Active power control with a Radio Ripple Control Receiver (RRCR).

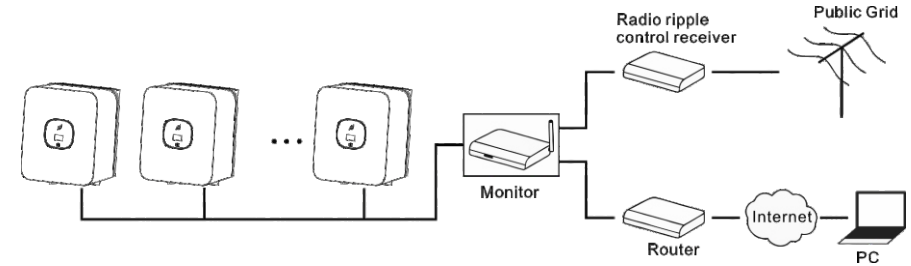

## 6.8 Inverter demand response modes (DRMS)

The inverter of this series features demand response modes, and the RJ45 terminal is used for DRED connection.

 <b>Information</b>	<p>DRMS application description</p> <ul style="list-style-type: none"> <li>➤ Applicable to AS/NZS4777.2:2015 or Commission Regulation (EU) 2016/631.</li> <li>➤ DRM0, DRM5, DRM6, DRM7, DRM8 are available.</li> </ul>
 <b>CAUTION</b>	<p>Damage to the inverter due to moisture and dust penetration</p> <ul style="list-style-type: none"> <li>➤ Make sure the cable gland has been tightened firmly.</li> <li>➤ The cable gland should be mounted properly to avoid any damage caused by moisture or dust, which is not covered by any warranty.</li> </ul>
 <b>WARNING</b>	<p>Excessive voltage can cause damage to the inverter. Ensure that the external voltage of the DRM port does not exceed +5V.</p>

### 6.8.1 RJ45 terminal pin assignment

Pin No.	Assignment for inverters capable of both charging and discharging	Pin assignments front view
1	DRM 5	
2	DRM 6	
3	DRM 7	
4	DRM 8	
5	RefGen	
6	Com/DRM0	
7	NC	
8	NC	

### 6.8.2 Method of asserting demand response modes

Mode	Socket Asserted by shorting pins		Function
DRM 0	5	6	The inverters shut down.
DRM 5	1	5	The inverters do not output active power.
DRM 6	2	5	The output active power of the inverters does not exceed 50% of the rated power.
DRM 7	3	5	The output active power of the inverters does not exceed 75% of the rated power.
DRM 8	4	5	The output active power of inverters recovers.

### 6.8.3 Using the Power Control Interface for EU

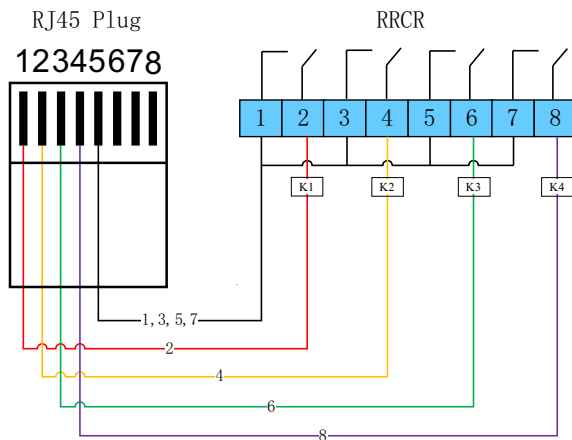

#### 6.8.3.1 The following table describes the connector pin assignment and function:

DRM Socket Pin NO.	Description	Connect to RRCR
1	Relay contact 1 input	K1 – Relay 1 output
2	Relay contact 2 input	K2 – Relay 2 output
3	Relay contact 3 input	K3 – Relay 3 output
4	Relay contact 4 input	K4 – Relay 4 output
5	GND	Relays common node
6	Not connected	Not connected
7	Not connected	Not connected
8	Not connected	Not connected

#### 6.8.3.2 The inverter is preconfigured to the following RRCR power levels:

DRMs Connector Pin1	DRMs Connector Pin2	DRMs Connector Pin3	DRMs Connector Pin4	Active power	Cos( $\varphi$ )
Short circuit with Pin5				0%	1
	Short circuit with Pin5			30%	1
		Short circuit with Pin5		60%	1
			Short circuit with Pin5	100%	1

Active power control and reactive power control are enabled separately.

## 6.9 AFCI (Optional)

### 6.9.1 Arc-Fault Circuit Interrupter (AFCI)

In accordance with Article 690.11 of the National Electrical Code R, the inverter is equipped with a system that can detect and interrupt electric arcs. The AFCI function is designed to interrupt any electric arc with a power of 300W or greater within a specified time outlined by UL 1699B. If the AFCI is tripped, it can only be reset manually. If you do not require the AFCI function, you can disable it via a communication product in "Installer" mode. Additionally, the 2011 edition of the National Electrical Code R, Section 690.11 mandates that newly installed PV systems attached to a building must have a means of detecting and disconnecting serial electric arcs (AFCI) on the PV side.

### 6.9.2 Danger information



Danger of fire from electric arc  
Only test the AFCI for false tripping in the order described below.  
Do not deactivate the AFCI permanently.

When an "Error 200" message is displayed and the buzzer alarms, it indicates that an electric arc has occurred in the PV system. As a safety measure, the AFCI has tripped and the inverter is in permanent shutdown mode.

Be aware of the large electrical potential differences between the conductors, which can cause the risk of arc flashes through the air when high-voltage current flows. Do not work on the product during operation. If the inverter displays an "Error 200" message, perform the following steps:

### 6.9.3 Operating steps

6.9.3.1 Turn the DC & AC Disconnect to the position "OFF".

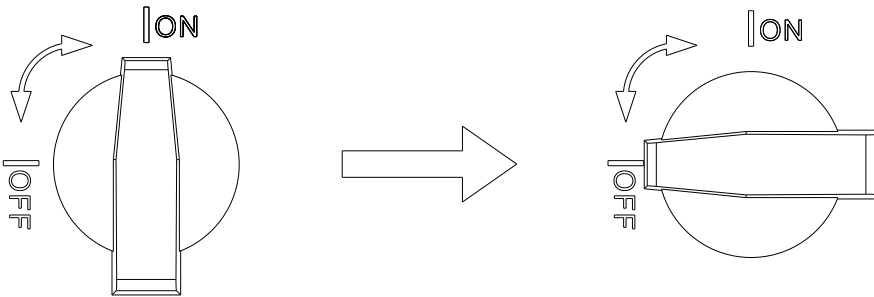

Wait until the display turns off.



6.9.3.2 Perform troubleshooting on the PV system:

Check the open circuit voltage of all PV strings.

6.9.3.3 After the fault is rectified, restart the inverter:

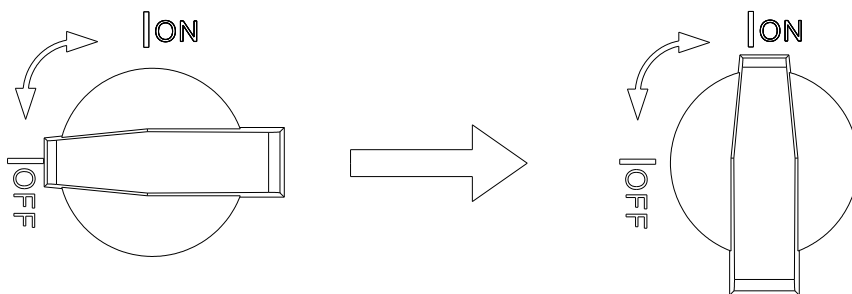
Turn the DC & AC Disconnect to the position "ON".



 <b>DANGER</b>	Do not disconnect the DC connectors under load.
 <b>WARNING</b>	Improper operation during the wiring process can cause fatal injury to operators or unrecoverable damage to the inverter. Only qualified personnel are allowed to perform the wiring work.
 <b>CAUTION</b>	Damage to the inverter due to moisture and dust penetration <ul style="list-style-type: none"> <li>➤ Make sure the cable gland has been tightened firmly.</li> <li>➤ The cable gland should be mounted properly to avoid any damage caused by moisture or dust, which is beyond the warranty scope.</li> </ul>

Requirements:

- ✓ The AC cable is correctly connected.
- ✓ The DC cable is correctly connected.
- ✓ The country settings on the inverter should be set correctly.

## 7.1 Starting the inverter

### 7.1.1 Touch control

Touch	Description
Single touch	Switch the display or increase the number shown by one
Double touch	Enter or confirm
Triple touch	Previous menu
Hold the key for 5s	Confirm the country setting or recover the number to its default value

### 7.1.2 Country setting

 <b>Information</b>	<b>Country setting</b> When the inverter is powered on, you need to select the correct country. If no country is selected, the inverter will default to AS/NZS4777.2 for Australia, or VDE0126-1-1 for other regions after 30 seconds.
-------------------------------------------------------------------------------------------------------------	-------------------------------------------------------------------------------------------------------------------------------------------------------------------------------------------------------------------------------------------

When inverter is powered on, the OLED screen will light up automatically. Once there is sufficient PV power, the OLED screen displays the following:

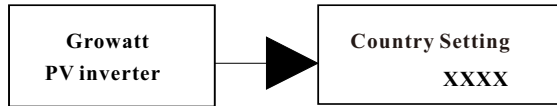

If we touch the touch button to scroll through the different countries, the screen will constantly change. For example, if you want to choose New Zealand, touch the touch button until the OLED panel shows "New Zealand" as below:



Press and hold the touch button for 5s, the OLED will indicate that the country setting is completed.

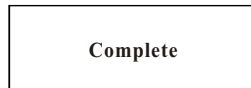

## 7.2 General settings

### 7.2.1 Set the display language

The inverter of this series offers multiple language options. Single touch to switch to a different language. Double touch to confirm you setting. Set the language as described below:

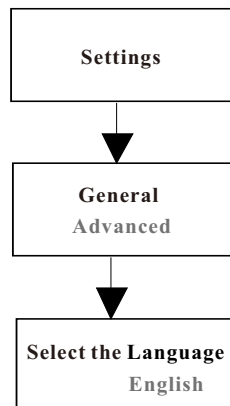

### 7.2.2 Set the COM address

By default, the COM address is set to 1. To change the COM address: Single touch to switch the display or increase the number by 1. Hold for 5 seconds to set the COM address to 001. Double touch to confirm your setting.

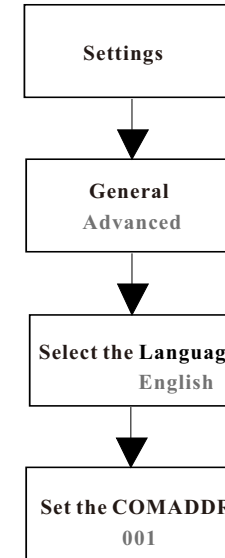

### 7.2.3 Set the date & time

Single touch to increase the number by 1. Double touch to confirm you setting. Hold for 5s to recover the number to the default value.

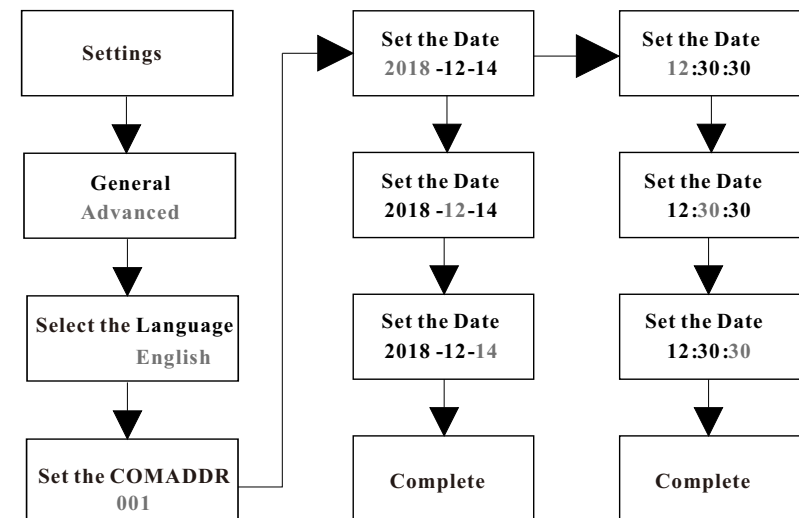

## 7.3 Advanced settings

### 7.3.1 Reset the country

Single touch to switch the display or increase the number by one.  
Double touch to confirm your setting.  
The password for accessing advanced settings is 123.

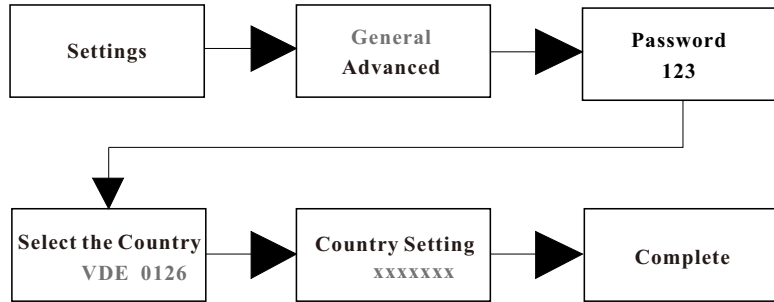

### 7.3.2 Export limitation settings

Single touch to switch the display or increase the number by one.  
Double touch to confirm your setting.

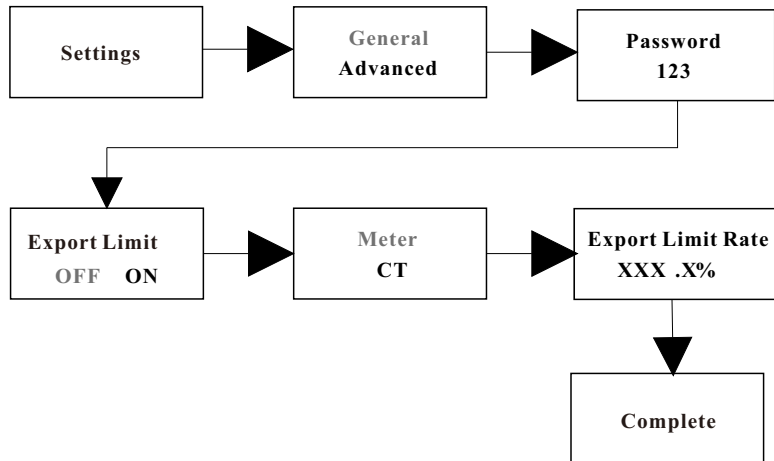

### 7.3.3 Restoring factory settings



**Information**

Take caution because after this operation, all parameters excluding the current date and time, will restore to the default factory settings.

Single touch to switch the display or increase the number by one. Double touch to confirm you setting.

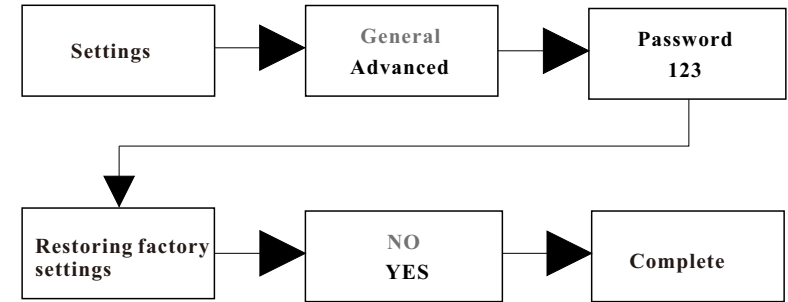

## 7.4 Communications

### 7.4.1 RS485

The inverter of this series provides two RS485 ports. One RS485 port can be used to monitor one or multiple inverters, while the other port is designated for use with a smart meter for export limitation functionality.

No.	Definition	No.	Definition	
1	N/A	5	CT-P	Signal for export Limitation (Optional)
2	N/A			
3	RS 485A1	7	RS 485A2	Signal for Smart meter
4	RS 485B1			
		8	RS 485B2	

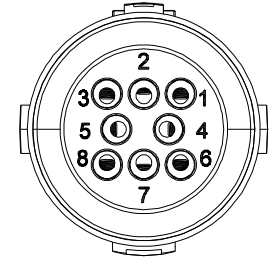

### 7.4.2 USB-A

The USB-A port is mainly used for monitoring and upgrading firmware. Remote monitoring can be enabled by connecting the devices, including Shine WIFI-X, Shine 4G-X, Shine LAN-X to the USB-A port. You can also update the firmware using a USB flash drive. Make sure the  $\Delta$  is facing forward when inserting the device to the USB port and fasten the screw.

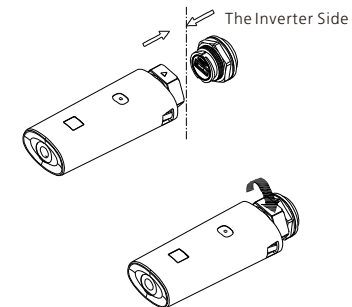

# 8 Powering on/off the Inverter

## 8.1 Powering on the inverter

1. Turn on the AC breaker between the inverter and the grid.
2. Turn on the DC switch, and the inverter will start automatically when the input voltage is higher than 70 V.

## 8.2 Powering off the inverter

 <p>DANGER</p>	Do not disconnect the DC connectors under load.
-------------------------------------------------------------------------------------------------	-------------------------------------------------

Steps to power off the inverter:

1. Disconnect the inverter from the single-phase grid by turning off the AC breaker and prevent it from being reactivated.
2. Turn off the DC switch.
3. Check the inverter operating status.
4. Wait a few minutes until the LED and OLED turn off to confirm that the inverter has been completely powered off.

# Maintenance and Cleaning 9

## 9.1 Checking the heat dissipation

For reduction in power output due to high temperature, you are advised to clean the heat sink to improve heat dissipation.

## 9.2 Cleaning the Inverter

Before cleaning an inverter, turn off the AC breaker and the DC switch and wait until the inverter completely shuts down. Clean the enclosure lid, the display and the LED indicators with a cloth moistened with clear water. Do not use any cleaning agents, such as solvents and abrasives, which may cause damage to the equipment and its components.

## 9.3 Checking the DC disconnect

To ensure safe operation of the system, it is recommended to periodically check the DC disconnect and cables for any visible damage or discoloration. If you notice any damage or discoloration, please contact your installer immediately.

- To extend the lifespan of the DC disconnect, it is recommended to turn the rotary switch from the On position to the Off position 5 times in a row once a year. This move will clean the contacts of the switch and ensure optimal performance.

# EU Declaration of Conformity 10

Comply with the following EU directives:

- 2014/35/EU Low Voltage Directive (LVD)
- 2014/30/EU Electromagnetic Compatibility Directive (EMC)
- 2011/65/EU RoHS Directive and its amendment (EU) 2015/863

Shenzhen Growatt New Energy Technology Co. Ltd confirms that the Growatt inverters and accessories described in this document are in compliance with the EU directives listed above. The complete EU Declaration of Conformity can be found at [www.ginverter.com](http://www.ginverter.com).

# 11 Troubleshooting

Growatt has a rigorous quality control program in place to ensure that each inverter is manufactured to precise specifications and is thoroughly tested before shipment. In case you encounter any difficulties with the operation of your inverter, we suggest that you review the following information to troubleshoot the problem.

## 11.1 Error Messages displayed on OLED

An error message will be displayed on the OLED screen when a fault occurs, indicating a system fault or an inverter fault. In some situations, you may need to contact Growatt for assistance. To provide you with the necessary support, we will need the following information from you:

- Serial number
- Model number
- Error message on the OLED display
- Brief description of the problem
- Grid voltage
- DC input voltage
- Can you reproduce the failure?
- Has this problem occurred in the past?
- What were the ambient conditions like when the problem occurred?

Information concerning the PV panels:

- Manufacturer name and model number of the PV panel
- Output power of the panel
- Voc of the panel
- Vmp of the panel
- Imp of the panel
- Number of panels in each string

If it is necessary to replace the unit, please ship it in the original box.

## 11.2 System faults

System faults (system faults are mainly caused by issues within the system instead of a fault with the inverter, please check the items as instructed below before replacing the inverter).

Error message	Description	Suggestion
Residual I High Error: 201	Leakage current too high	1. Restart the invert. 2. If the error message persists, contact Growatt.
PV Voltage High Error: 202	The DC input voltage exceeds the upper threshold	1. Disconnect the DC switch immediately. 2. Check the voltage of each PV string with a multimeter. 3. If the voltage of the PV string is lower than 550V, contact Growatt.

Error message	Description	Suggestion
PV Isolation Low Error: 203	A low level of isolation between the PV array and the ground	1. Check if the panel enclosure is grounded properly. 2. Check if the inverter is grounded properly. 3. Check if the DC breaker gets wet. 4. Check the impedance between the PV (+) & PV (-) terminals and the ground, which must be greater than 25 K $\Omega$ or 500 K $\Omega$ (according to VDE 0126 standards). If the error message persists, contact Growatt.
AC V Outrange Error: 300	The grid voltage is beyond the acceptable range	1. Switch off the DC switch. Check the AC wiring, paying extra attention to the neutral and ground wires. 2. Check if the grid voltage complies with local grid standards. Restart the inverter, if the problem persists, Contact Growatt.
No AC connection Error: 302	No AC connection	1. Check the AC wiring. 2. Check the status of the AC breaker.
PE abnormal Error: 303	Voltage of the Neutral and PE cables are above 30V	1. Check the voltage of the Neutral and PE cables. 2. Check the AC wiring. 3. Restart the inverter, if the error message persists, contact the manufacturer.
AC F Outrange Error: 304	The frequency of the utility grid is outside the acceptable range	1. Switch off the DC switch. 2. Check the AC wiring, paying extra attention to the neutral and ground wires. 3. Check if the grid frequency complies with local grid standards. Restart the inverter, if the problem persists, Contact Growatt.
Auto Test Failed Error: 407	Self-test fails	1. Restart the inverter, repeat the Auto Test. 2. Restart the inverter. If the problem persists, contact Growatt.

### 11.3 Inverter warning

Warning code	Meanings	Suggestion
Warning202	DC SPD function abnormal	1. After shutdown, check the DC SPD. 2. If the error message persists, contact the manufacturer.
Warning 203	A short circuit in the PV1 or PV2 circuit	1. Check the PV panel polarity. 2. Restart the inverter. If the warning persists, please contact Growatt customer service to replace the POWER board.
Warning 204	Dry connect function abnormal	1. After shutdown, check the dry connect wiring. 2. If the error message persists, contact the manufacturer.
Warning 205	PV1 or PV2 boost failure	Restart the inverter. If the warning persists, please contact Growatt customer service to replace the power board.
Warning 207	USB over-current	1. Unplug the U disk or the monitor. 2. Re-access the U disk or the monitor after shutdown. 3. If the error message persists, contact the manufacturer.
Warning 401	Abnormal communication between the inverter and the meter	1. Check if the meter is on. 2. Check the connection between the inverter and the meter.
Warning 404	EEPROM abnormal	Restart the inverter. If the warning persists, please contact Growatt customer service to replace the M3 board.
Warning 405	Inconsistent firmware version	Update the firmware to the correct version.

### 11.4 Inverter faults

Error code	Meanings	Suggestion
Error 200	AFCI fault	1. After shutdown, check the PV panel terminals. 2. Restart the inverter. 3. If the error message persists, contact Growatt.
Error 402	Output High DCI	Restart the inverter. If the problem persists, contact Growatt.
Error 404	Bus sample fault	Restart the inverter. If the problem persists, contact Growatt.
Error 405	Relay fault	Restart the inverter. If the problem persists, contact Growatt.
Error 408	Over Temperature	Wait until the ambient temperature of the inverter is lower than 60°C and restart the inverter. If the problem persists, contact Growatt.
Error 409	Bus over voltage	Restart the inverter. If the problem persists, contact Growatt.
Error 411	DSP communicates with M3 abnormal	Restart the inverter. If the problem persists, contact Growatt.
Error 414	EEPROM fault	Restart the inverter. If the problem persists, contact Growatt.
Error 417	Inconsistency between data collected by the DSP and the redundant M3	Restart the inverter. If the problem persists, contact Growatt.
Error 420	GFCI fault	Restart the inverter. If the problem persists, contact Growatt.
Error 425	AFCI self-test fault	Restart the inverter. If the problem persists, contact Growatt.

# 12 Warranty

Please refer to the warranty card.

# 13 Decommissioning

## 13.1 Dismantling the Inverter

1. Disconnect the inverter as described in Section 8.
2. Remove all cables connected to the inverter.



Burn warning. After the system powers off, the remaining heat may still cause body burns. Therefore, wait for 20 minutes before disassembling until the chassis cools down.

3. Unscrew all projecting cable glands.
4. Lift the inverter off the bracket and unscrew the bracket screws.

## 13.2 Packing the Inverter

If possible, use the original carton that the inverter came in. If the original carton is not available, use an equivalent carton that can accommodate the dimensions and weight of the inverter.

## 13.3 Storing the Inverter

Store the inverter in a dry place and keep the ambient temperature at -30°C to +60°C.

## 13.4 Disposing of the Inverter



Do not dispose of faulty inverters or accessories together with household waste. Make sure to follow the electronic waste disposal regulations that are in effect at the installation site. Ensure that the old unit and, where applicable, any accessories are disposed of in a proper manner.

# Technical Data 14

## 14.1 Specifications

Model	MIC 600TL-X2	MIC 750TL-X2	MIC 800TL-X2	MIC 1000TL-X2	MIC 1500TL-X2
<b>Specifications</b>					
Input data (DC)					
Max. recommended PV power (for module STC)	900W	1120W	1200W	1500W	2250W
Max. DC voltage	500V				
Start voltage	50V				
Nominal voltage	360V				
MPP voltage range	50V-500V				
MPP voltage range at Full Power	50V-450V	50V-450V	53V-450V	65V-450V	100V-450V
No. of MPP trackers	1				
No. of PV strings per MPP trackers	1				
Max. input current per MPP trackers	16A				
Max. short-circuit current per MPP trackers	24A				
DC overvoltage category	Category II				
Output data (AC)					
AC nominal power	600W	750W	800W	1000W	1500W
Max. AC apparent power	600VA	750VA	800VA	1000VA	1500VA
Nominal AC voltage/range*	230V/180~280V				
AC grid frequency/range	50-60Hz/44-55Hz;54-65Hz				
Max. output current	2.9A	3.6A	3.8A	4.8A	7.1A
Inrush current	<10A				
Max output fault current	66A				
Max output overload protection	10A	10A	10A	10A	10A
Backfeed current	0A				
Power factor (@nominal power)	>0.99				
Adjustable power factor	0.8leading... 0.8lagging				
THDi	<3%				
AC grid connection type	Single phase				
AC overvoltage category	Category III				

Model Specifications	MIC 600TL-X2	MIC 750TL-X2	MIC 800TL-X2	MIC 1000TL-X2	MIC 1500TL-X2
Efficiency					
Max. efficiency	96.5%	97.4%	97.4%	97.4%	97.4%
Euro-eta	95.5%	96.5%	96.5%	96.5%	97.0%
Protection devices					
DC reverse-polarity protection	Integrated				
DC switch	Integrated				
DC Surge protection	Type III				
Insulation resistance monitoring	Integrated				
AC surge protection	Type III				
AC short-circuit protection	Integrated				
Ground fault monitoring	Integrated				
Grid monitoring	Integrated				
Anti-islanding protection	Integrated				
Residual-current monitoring unit	Integrated				
General data					
Dimensions (W / H / D) in mm	274*254*138				
Weight	6.0 kg				
Operating temperature range	- 30 °C to +60 °C				
Noise emission (typical)	≤ 25 dB(A)				
Altitude	4000m				
Internal consumption at night	<0.5W				
Topology	transformerless				
Cooling	Natural convection				
Protection degree	IP66				
Relative humidity	0~100%				
DC connection	VP-D4/MC4(Optional)				
AC connection	AC connector				

Model Specifications	MIC 600TL-X2	MIC 750TL-X2	MIC 800TL-X2	MIC 1000TL-X2	MIC 1500TL-X2
Interfaces					
Display	OLED+LED				
RS485/USB	Integrated				
WIFI/GPRS/4G/LAN/ RF	Optional				
Warranty:5/10 years	Yes/ Optional				

Model	MIC 2000TL-X2	MIC 2500TL-X2	MIC 3000TL-X2	MIC 3300TL-X2
<b>Specifications</b>				
Input data (DC)				
Max. recommended PV power (for module STC)	3000W	3750W	4500W	4950W
Max. DC voltage	500V	550V	550V	550V
Start voltage	50V			
Nominal voltage	360V			
MPP voltage range	50V-500V	50V-550V	50V-550V	50V-550V
MPP voltage range at Full Power	130V-450V	160V-500V	195V-500V	215V-500V
No. of MPP trackers	1			
No. of PV strings per MPP trackers	1			
Max. input current per MPP trackers	16A			
Max. short-circuit current per MPP trackers	24A			
DC overvoltage category	Category II			
Output data (AC)				
AC nominal power	2000W	2500W	3000W	3300W
Max. AC apparent power	2000VA	2500VA	3000VA	3300VA
Nominal AC voltage/range*	230V/180~280V			
AC grid frequency/range	50-60Hz/44-55Hz;54-65Hz			
Max. output current	9.5A	11.9A	14.3A	14.3A
Inrush current	<10A			
Max output fault current	66A			
Max output overload protection	16A	16A	16A	16A
Backfeed current	0A			
Power factor (@nominal power)	>0.99			
Adjustable power factor	0.8leading... 0.8lagging			
THDi	<3%			
AC grid connection type	Single phase			
AC overvoltage category	Category III			

Model	MIC 2000TL-X2	MIC 2500TL-X2	MIC 3000TL-X2	MIC 3300TL-X2
<b>Specifications</b>				
Efficiency				
Max. efficiency	97.4%	97.6%	97.6%	97.6%
Euro-eta	97.0%	97.0%	97.1%	97.1%
Protection devices				
DC reverse-polarity protection	Integrated			
DC switch	Integrated			
DC Surge protection	Type III			
Insulation resistance monitoring	Integrated			
AC surge protection	Type III			
AC short-circuit protection	Integrated			
Ground fault monitoring	Integrated			
Grid monitoring	Integrated			
Anti-islanding protection	Integrated			
Residual-current monitoring unit	Integrated			
General data				
Dimensions (W / H / D) in mm	274*254*138			
Weight	6.0 kg		6.2 kg	
Operating temperature range	- 30 °C to +60 °C			
Noise emission (typical)	≤ 25 dB(A)			
Altitude	4000m			
Internal consumption at night	<0.5W			
Topology	transformerless			
Cooling	Natural convection			
Protection degree	IP66			
Relative humidity	0~100%			
DC connection	VP-D4/MC4(Optional)			
AC connection	AC connector			

# Compliance Certificates 15

## Certificates

With the appropriate settings, the unit will comply with the requirements specified in the following standards and directives (dated: April/2020):

Model	Certificates
MIC 600-3300TL-X2	CE , IEC 62109,IEC62116/61727,IEC60068/61683, VDE0126-1-1,EN 50549,C10/11,Inmetro

Model	MIC 2000TL-X2	MIC 2500TL-X2	MIC 3000TL-X2	MIC 3300TL-X2
<b>Specifications</b>				
<b>Interfaces</b>				
Display	OLED+LED			
RS485/USB	Integrated			
WIFI/GPRS/4G/LAN/ RF	Optional			
Warranty:5/10 years	Yes/ Optional			

\* The AC Voltage Range may vary depending on the grid standard of each country. All specifications are subject to change without notice. The MIC 600TL-X2 model is only available in Germany.

## 14.2 DC & AC connector info

DC connector	VP-D4/ MC4(opt)
AC connector	EN030-2028-1001 VPAC06EP-3S(SC) VPAC06EW-3P(SC4)

## 14.3 Torque

Enclosure lid screws	12kgf.cm
AC terminal	6kgf.cm
Signal terminal	4kgf.cm
Safety screw	12kgf.cm
Additional ground screws	12kgf.cm

## 14.4 Accessories

The table below lists the optional accessories available for your product. You can purchase them from GROWATT NEW ENERGY TECHNOLOGY CO., LTD or your dealer.

Name	Brief description
Shine WIFI-X	WIFI monitor with USB interface
Shine 4G-X	4G monitor with USB interface
Shine Link-X	RF monitor with USB interface
Shine LAN-X	LAN monitor with USB interface

If your product becomes defective, you have the option to send it to a Growatt service center for repair, or have it fixed on-site, or replace it with an equivalent device based on its model and age. Please note that the warranty does not cover transportation expenses associated with returning faulty modules. Furthermore, the cost of installing or reinstalling the modules and any other logistics or process-related costs incurred by any party regarding this warranty claim are explicitly not covered.

# 16 Contact

If you experience any technical issues with our products, please contact the GROWATT service line for assistance. To provide you with the necessary support, we will need the following information from you:

- Inverter model
- Serial number of the inverter
- Error code or message displayed on the inverter
- Type and number of PV modules connected
- Optional equipment

## **Shenzhen Growatt New Energy Co., Ltd**

4-13/F, Building A, Sino-German (Europe) Industrial Park,  
Hangcheng Ave, Bao'an District, Shenzhen, China

**T** +86 0755 2747 1942

**E** [service@ginverter.com](mailto:service@ginverter.com)

**W** [www.ginverter.com](http://www.ginverter.com)