

Energy Storage Inverter ME3000SP

User Manual



2019-5-20

V1.7 (For ME3000SP firmware V1.7 or newer)

Contents

1.	ME3000SP Introduction	1
2.	Safety Notes	2
2.1	Safety Notes	2
2.2	Installation and Maintenance Notes	2
3.	Installation	4
3.1	Product Overview	4
3.2	Packing List	5
3.3	Installation Environment	6
3.4	Installation Tools	6
3.5	Installation Position	8
3.6	Mount ME3000SP	8
4.	Electrical Connection	10
4.1	Battery Connection	11
4.2	Inverter Logic Interface connection	12
4.3	CT / RS485 / NTC connection	16
4.4	Grid Connection	19
4.5	Critical Load Connection (EPS function)	20
4.6	WIFI/GPRS module installation procedure:	21
5.	Buttons and indicator lights	22
5.1	Buttons:	22
5.2	Indicator lights:	22
5.3	Status of ME3000SP	23
6.	Operation	24
6.1	Double Check	24

6.2	First Time Setup (IMPORTANT!)	24
6.3	Commissioning	28
6.4	Menu	29
6.4.1	Enter setting:	29
6.4.2	Event List	39
6.4.3	System information interface	39
6.4.4	Software upgrade	40
6.4.5	Energy Statistic:	41
7.	Technical Data	43
8.	Troubleshooting	45
9.	Quality Assurance	50

1. ME3000SP Introduction

ME3000SP is an AC coupled bi-directional battery converter. Customers can purchase batteries & ME3000SP as an energy storage add-on to his/her existing renewable energy system. ME3000SP helps to achieve optimal usage of renewable energy. ME3000SP controls bi-directional flow of electric power, work under auto or time-of-use (TOU) modes, charge / discharge the battery when needed.

In auto mode, ME3000SP will charge surplus renewable energy into the battery & discharge battery to supply power to local load when renewable energy is not enough.

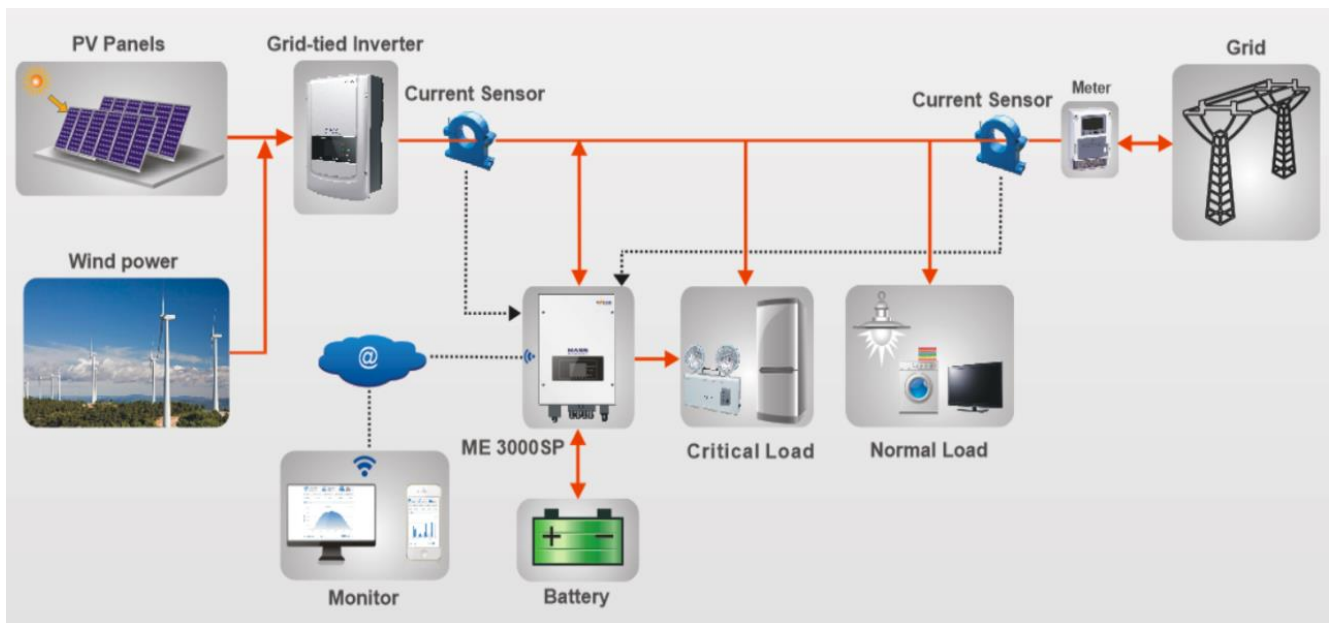

Fig. 1 ME3000SP schematic diagram

2. Safety Notes

Before installation, please make sure you read & understand this manual. ME3000SP strictly comply with safety rules of design and testing. During the installation, operation and maintenance, operators should abide by local safety regulations. Improper operation may cause an electric shock or damage the equipment and properties.

2.1 Safety Notes

- ✧ Electrical installation and maintenance must be carried out by competent electricians according to local regulations.
- ✧ ME3000SP can only be installed by qualified electrician, and only those who have appropriate accreditation, as required by local authority.
- ✧ Do NOT put explosives or flammable materials, e.g. gasoline, kerosene, oil, wood slab, cotton, or rag close to batteries / ME3000SP.
- ✧ Disconnect DC (battery) & AC (grid & load) first, then wait at least 5 minutes (discharge capacitors) before maintenance to prevent electric shock.
- ✧ ME3000SP shall be disconnected completely (DC & AC) while being maintained.
- ✧ ME3000SP can be very hot while working. Switch off ME3000SP & wait ME3000SP to cool down before maintenance.
- ✧ Keep children away from batteries & ME3000SP.
- ✧ It's not allowed to open the front cover of ME3000SP. This will void the product warranty.
- ✧ ME3000SP damaged by improper installation/operation is not covered by the product warranty.

2.2 Installation and Maintenance Notes

- ✧ The battery has been ~ 60% charged before being delivered and shall be prevented from short circuit during transportation and installation.
- ✧ ME3000SP/batteries shall be placed in a well-ventilated place. Do not put the ME3000SP/batteries in an airtight or badly ventilated place or cabinet. This can be very harmful to system performance & system service life.

- ✧ Keep ME3000SP/batteries away from direct sunshine. Don't put ME3000SP/batteries close to a furnace or fire. The can lead battery to leak even explode.
- ✧ The current capacity of DC power cables (from battery to inverter) should be at least 90A. Use short power cables to avoid high voltage drop & power loss.
- ✧ Use a multimeter to check the batter voltage & polarity before switching ON batteries. Make sure connections are correct according to this manual.
- ✧ If you want to store the batteries without using them, they should be disconnected from ME3000SP, and be kept in a cool, dry, and ventilated environment.
- ✧ Battery maintenance operators shall have the knowledge and technical skill for battery maintenance;
- ✧ All batteries connected in parallel should be of the same model, and have same firmware version. This is a design issue needs to be considered by designer/installer, particularly when replacing batteries or modifying an existing energy storage system.
- ✧ Warning: Do not disassemble or break the battery. Its electrolyte can be toxic and damage your skin and eyes.
- ✧ Warning: follow the following rules during battery installation/maintenance.
 - a) Take off your watch, ring, and other metal objects.
 - b) Only use tools with insulated handles.
 - c) Wear rubber gloves and shoes.
 - d) Do not put tools or metals above the battery.
 - e) Switch off ME3000SP & batteries before connecting / disconnecting battery terminals.
 - f) Battery positive / negative poles should be isolated from ground.

3. Installation

3.1 Product Overview

ME3000SP is 100% strictly inspected before package and delivery. It is forbidden to put ME3000SP upside down during delivery.

Please check the product package and fittings carefully before installation.

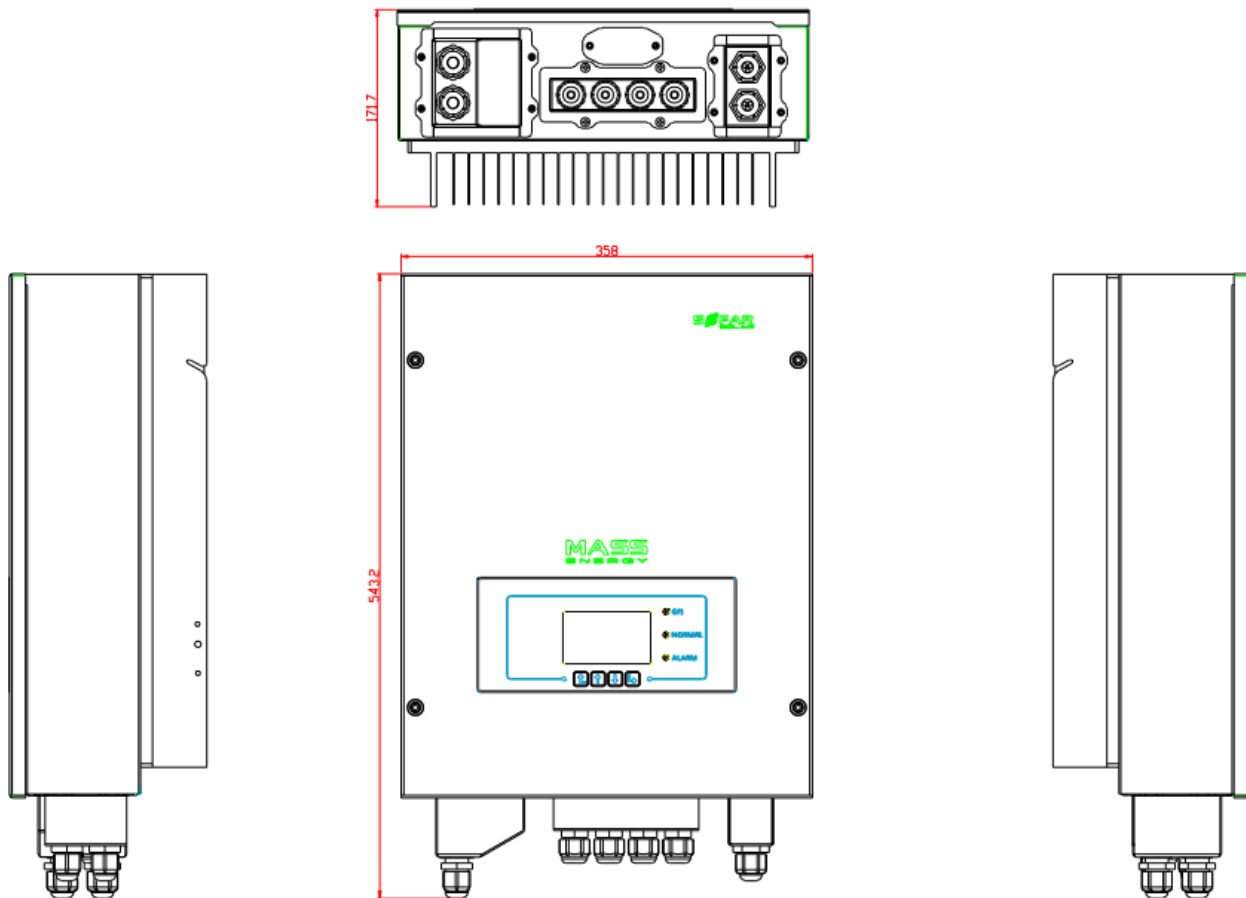

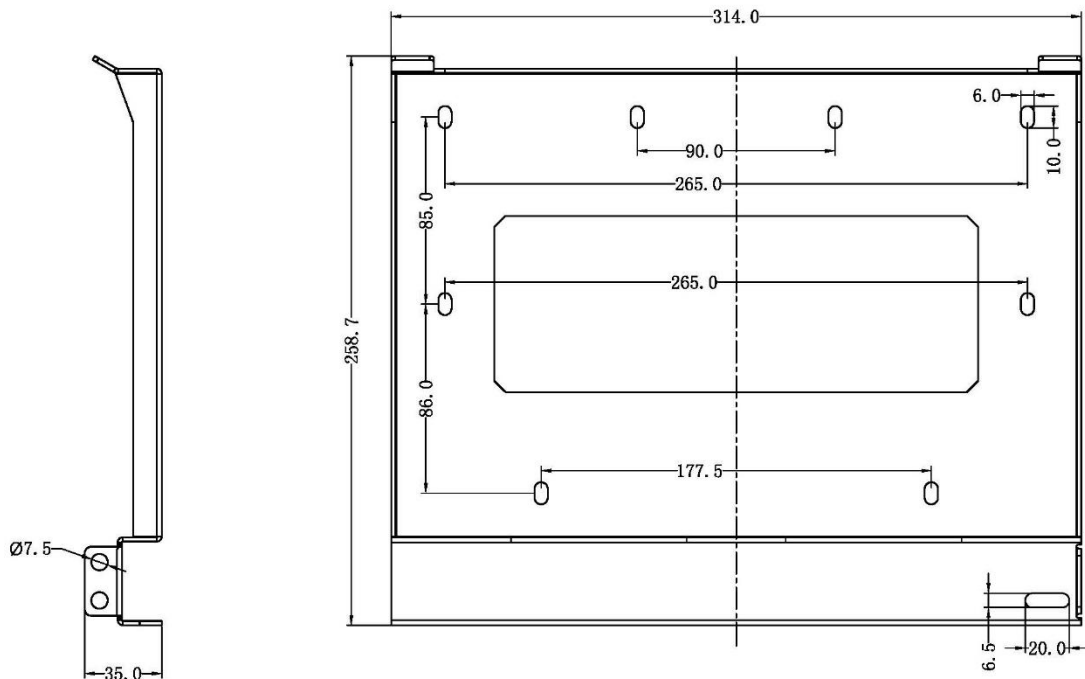
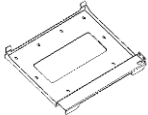

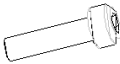

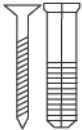

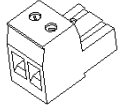

Fig. 2 ME3000SP & mounting bracket

3.2 Packing List

Inspect the package and fittings carefully before installation. You should have the following fittings:

 Mounting Bracket × 1	 AC terminal × 6	 M5 screw × 2	 Battery terminal × 2
 M6 flat washer × 8	 Expansion Bolts × 8	 Terminal cap × 4	 CT terminal × 2





 Current Transformer × 2	 User Manual × 1	 Warranty card × 1	 Quality Certificate × 1
 Communication cable × 1			

Fig. 3 Accessories of ME3000SP



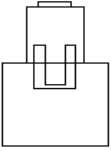

3.3 Installation Environment

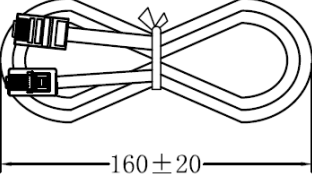
- Choose a dry, clean, and tidy place, convenient for installation
- Ambient temperature range: -25C ~ 60C
- Relative humidity: 0 ~ 100% (non-condensed)
- ME3000SP shall be installed in a well-ventilated place
- No flammable or explosive materials close to ME3000SP
- ME3000SP shall be connected to the electrical grid with an overvoltage category III or category II
- Maximum altitude: 2000m

3.4 Installation Tools

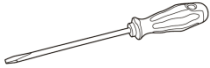
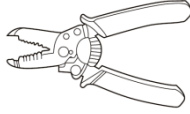
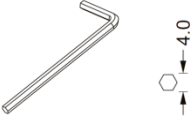
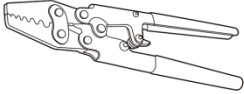
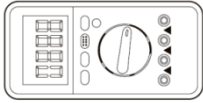
The following tools shall be prepared before installation:

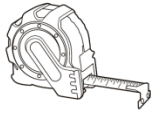
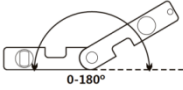
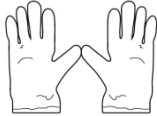
No.	Tool	Model	Function
1		Hammer drill Recommend drill dia.6mm	Used to drill holes on the wall

2		Screwdriver	wiring
3		Wire stripper	Strip wire
4		4mm Allen Key	Turn the screw to connect rear panel with inverter
5		Crimping tools	Used to crimp power cables
6		Multi-meter	Used to check grounding
7		Marker pen	Used to mark signs
8		Measuring tape	Used to measure distances
9		Level	Used to ensure that the rear panel is properly installed
10		ESD gloves	Operators wear
11		Safety goggles	Operators wear
12		Anti-dust respirator	Operators wear

3.5 Installation Position

ME3000SP should be vertically mounted (to ensure fast heat dissipation), please choose a position without direct sunlight / snow accumulation to install ME3000SP.

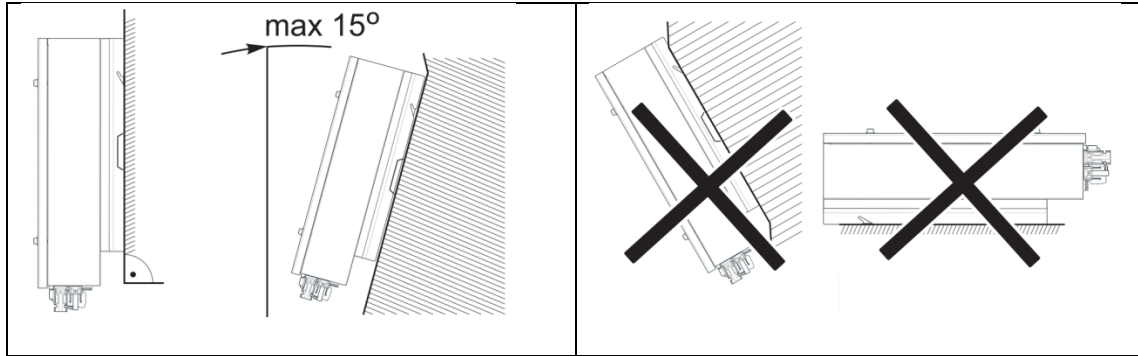

Fig. 4 Installation Position of ME3000SP

3.6 Mount ME3000SP

Step 1: Put the mounting bracket properly on the wall, mark these 8 drill holes using a marker pen. Drill 8 holes (drill bit 6mm) on the wall.

Step 2: Insert the expansion screw vertically into the hole, note the insertion depth. (not too shallow or too deep)

Step 3: Fix the mounting bracket on the wall using bolts & flat washers.

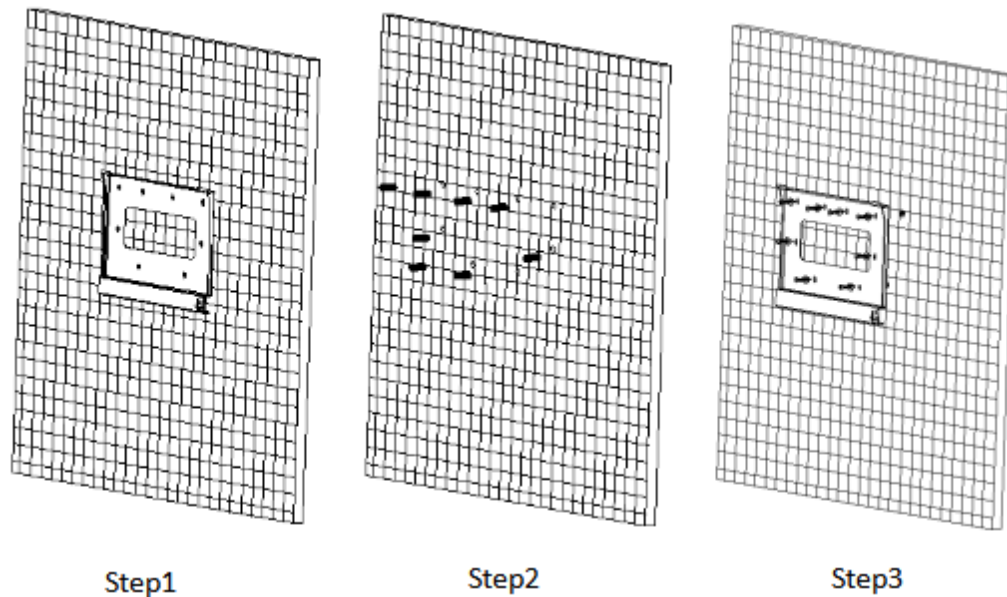

Step 4: Put ME3000SP on the mounting bracket.

Step 5: Earth ME3000SP using the grounding hole on the heat sink.

Step 6: OPTIONAL: you can lock ME 3000SP to the mounting bracket.

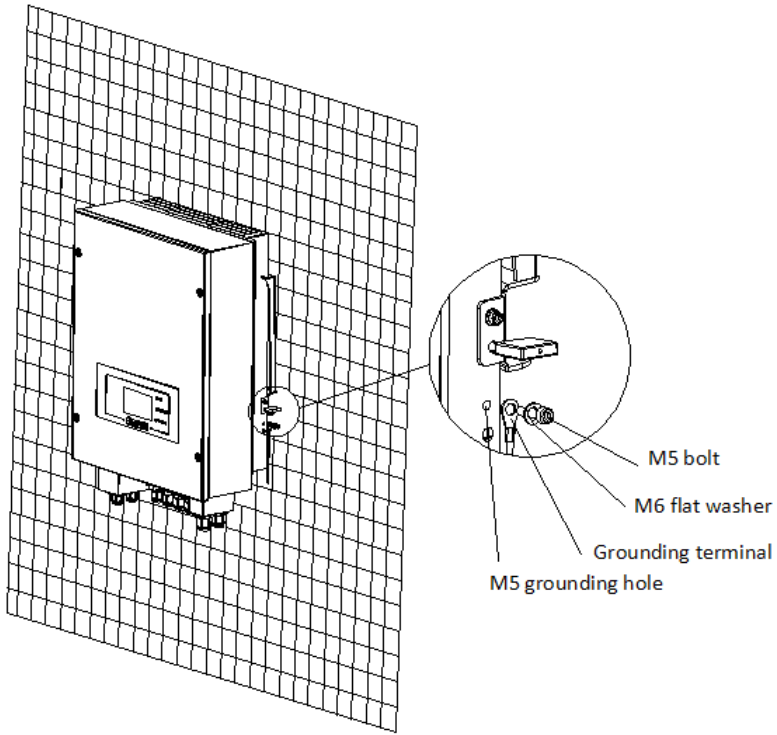

Step 5

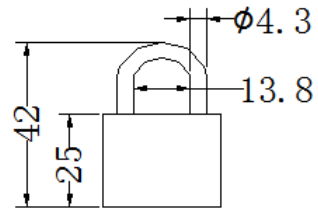

Step 6

4. Electrical Connection



Warning

- Be aware of electric shock and chemical hazards!
- Use a multi-meter to check the DC polarity before connecting the DC power cable between battery & ME3000SP.
- It's recommended to install a rotary DC isolator (100A) between ME3000SP and batteries. Thus, ME3000SP can be securely disconnected during installation/maintenance.
- It's necessary to install a AC circuit breaker (25A) between ME3000SP and electrical grid.
- It is very important for system safety and efficient operation to use appropriate cable for electrical connection.
 - Battery connection: AWG8 or AWG6 cable.
 - Grid & Load connection: AWG12 cable.
- Make sure N wire is connected to PE wire while EPS (Emergency Power Supply) mode is enabled.

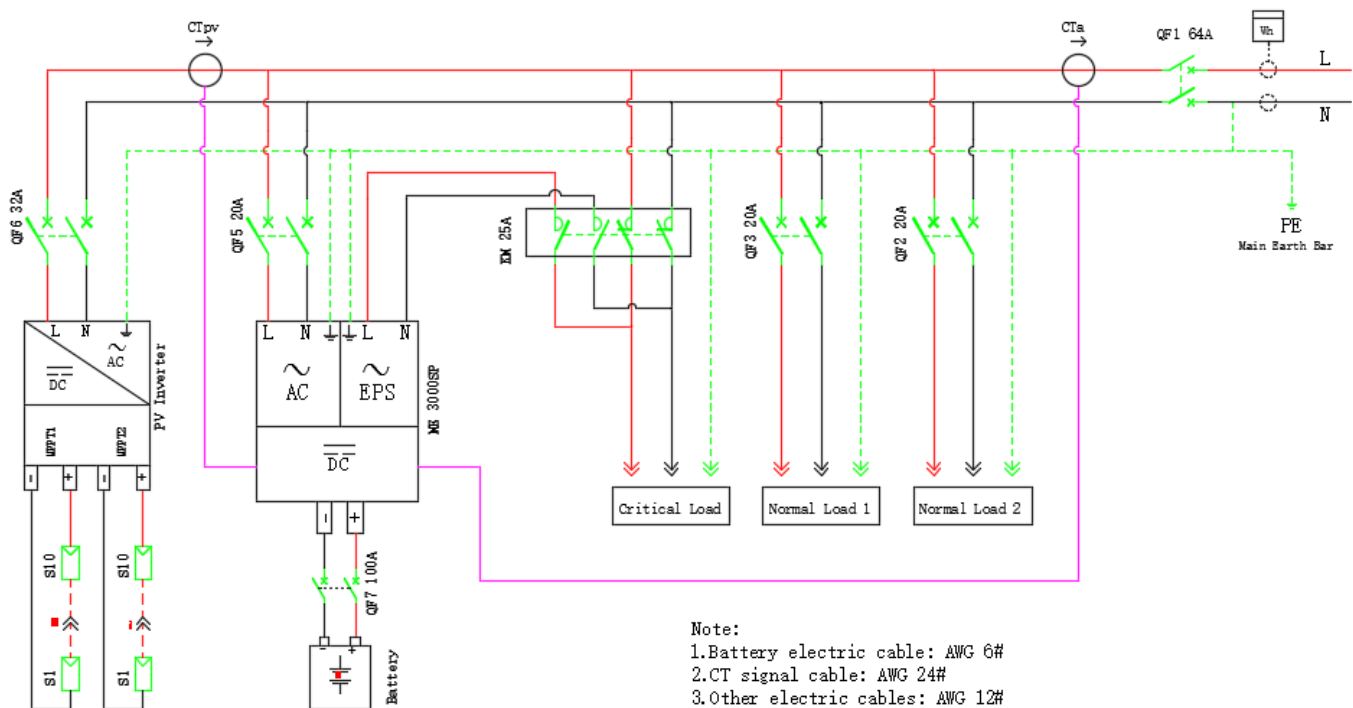

Fig. 5 Wiring Schematic of Single Phase System

4.1 Battery Connection

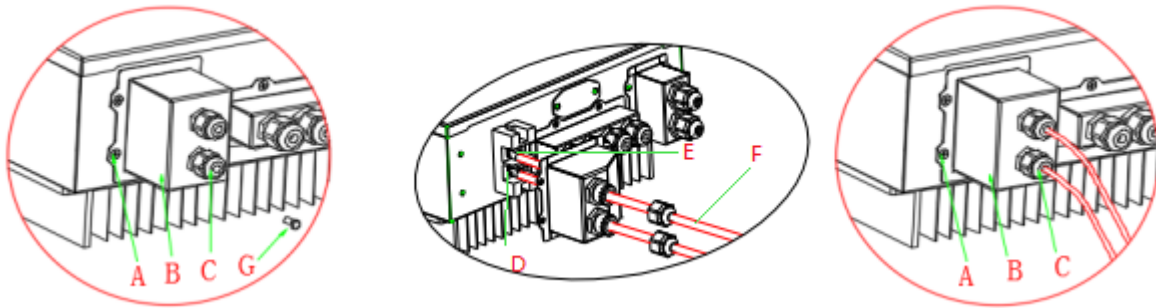

Fig. 6 Battery connection (Test battery wires polarity before connection)

Step 1: Loosen 4 screws (A) using a screwdriver (fig. 6);

Step 2: Remove the waterproof cover (B), loosen the cable gland (C), and then remove the stopper (G);

Step 3: Route the battery wires (F) through the cable gland, then connect battery wires using OT terminal (E);

Step 4: Fasten the waterproof cover using 4 screws.

4.2 Inverter logic interface connection

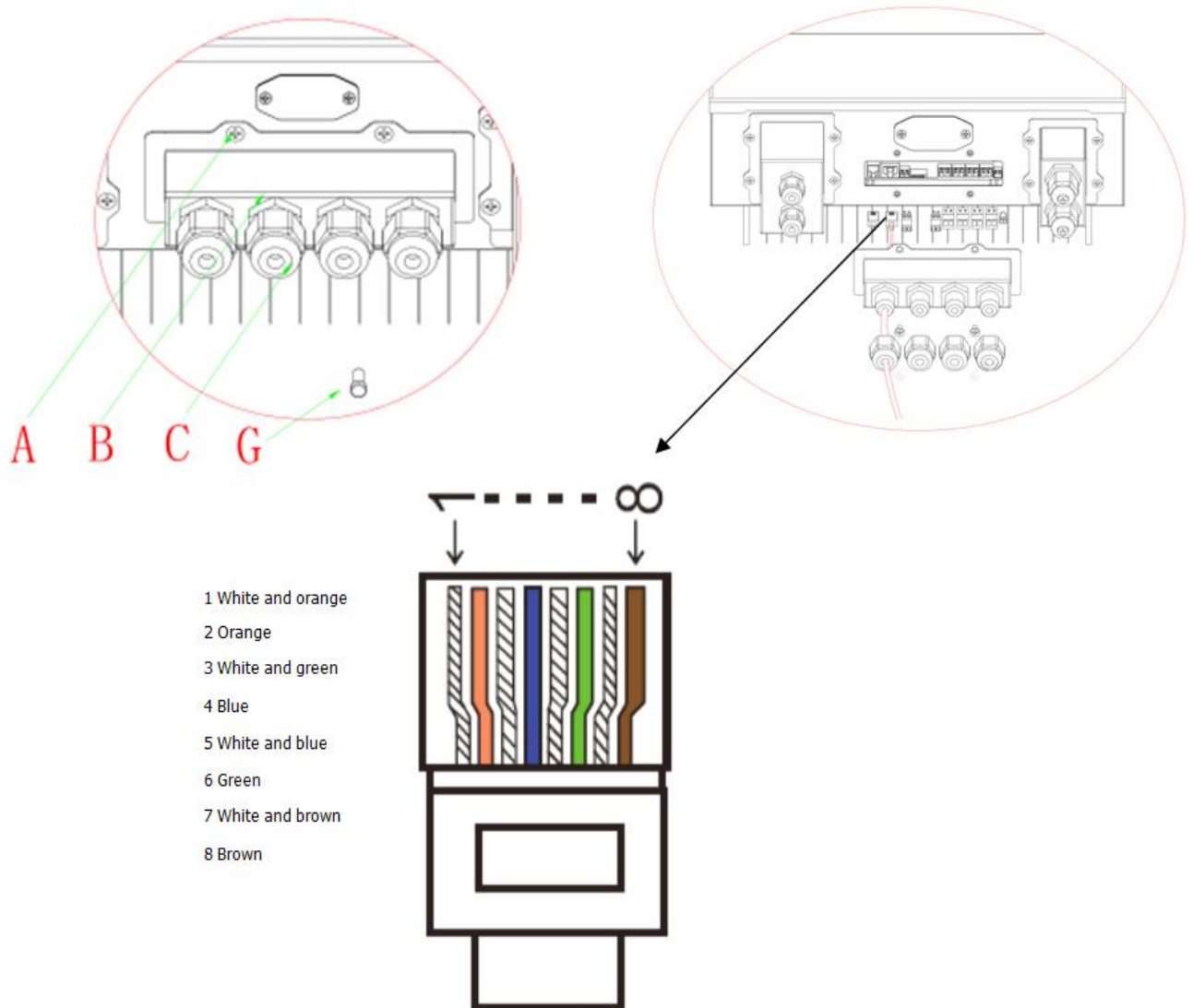

Fig. 7 Inverter logic interface connection

Step 1: Loosen 4 screws (A) using a screwdriver (fig. 7);

Step 2: Remove the waterproof cover (B), Loosen the cable gland (C), and then remove the stopper (G);

Step 3: Press the wire terminals in color sequence;

Step 4: Route Cable terminal through the cable gland, Insert the communication cable into the RJ45 connector;

Step 5: Fasten the waterproof cover using 4 screws.

The logic interface pin definitions and circuit connections are as follows:

Logic interface pin are defined according to different standard requirements

(a) Logic interface for AS/NZS 4777.2:2015, also known as inverter demand response modes (DRMs).

The inverter will detect and initiate a response to all supported demand response commands within 2 s. The inverter will continue to respond while the mode remains asserted.

Table 4-1 Function description of the DRMs terminal

Pin NO.	Color	Function
1	White and orange	DRM1/5
2	Orange	DRM2/6
3	White and green	DRM3/7
4	Blue	DRM4/8
5	White and blue	DRM0
6	Green	RefGen
7	White and brown	Pin7&Pin8 short internal
8	Brown	

- (b) Logic interface for VDE-AR-N 4105:2018-11, is in order to control and/or limit the inverter's output power. The inverter can be connected to a RRCR (Radio Ripple Control Receiver) in order to dynamically limit the output power of all the inverters in the installation.

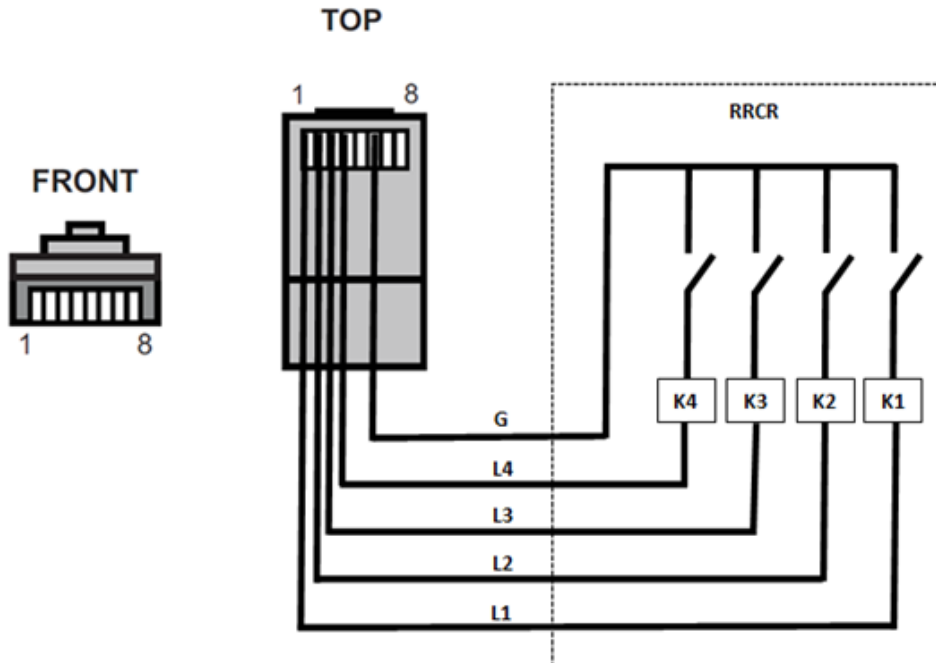

Fig.8 Inverter – RRCR Connection

Table 4-2 Function description of the terminal

Pin NO.	Pin name	Description	Connected to (RRCR)
1	L1	Relay contact 1 input	K1 - Relay 1 output
2	L2	Relay contact 2 input	K2 - Relay 2 output
3	L3	Relay contact 3 input	K3 - Relay 3 output
4	L4	Relay contact 4 input	K4 - Relay 4 output
5	NC	Not Connected	Not Connected
6	G	GND	Relays common node
7	NC	Not Connected	Not Connected
8	NC	Not Connected	Not Connected

Table 4-3 The inverter is preconfigured to the following RRCR power levels

Relay status: close is 1, open is 0

L1	L2	L3	L4	Active Power	Cos(ϕ)
1	0	0	0	0%	1
0	1	0	0	30%	1
0	0	1	0	60%	1
0	0	0	1	100%	1

- (c) Logic interface for EN50549-1:2019, is in order to cease active power output within five seconds following an instruction being received at the input interface.

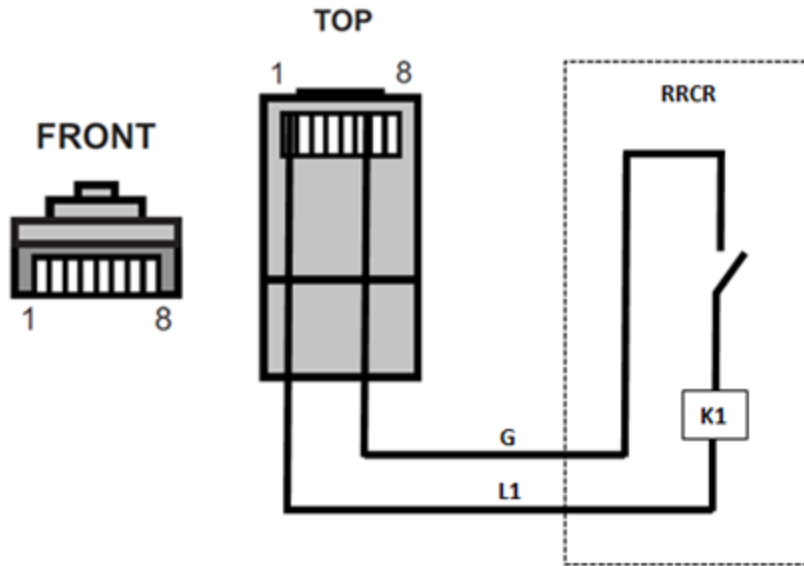

Fig.9 Inverter – RRCR Connection

Table 4-4 Function description of the terminal

Pin NO.	Pin name	Description	Connected to (RRCR)
1	L1	Relay contact 1 input	K1 - Relay 1 output
2	NC	Not Connected	Not Connected
3	NC	Not Connected	Not Connected
4	NC	Not Connected	Not Connected
5	NC	Not Connected	Not Connected
6	G	GND	K1 - Relay 1 output
7	NC	Not Connected	Not Connected
8	NC	Not Connected	Not Connected

Table 4-5 The inverter is preconfigured to the following RRCR power levels

Relay status: close is 1, open is 0

L1	Active Power	Power drop rate	Cos(ϕ)
1	0%	< 5 seconds	1
0	100%	/	1

4.3 CT / RS485 / NTC connection

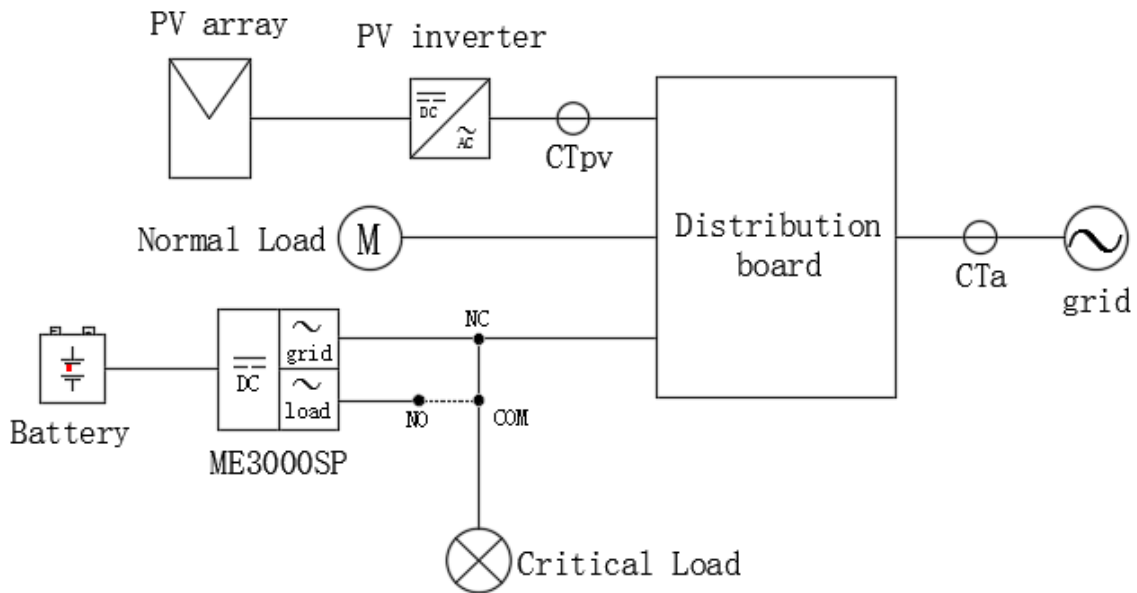
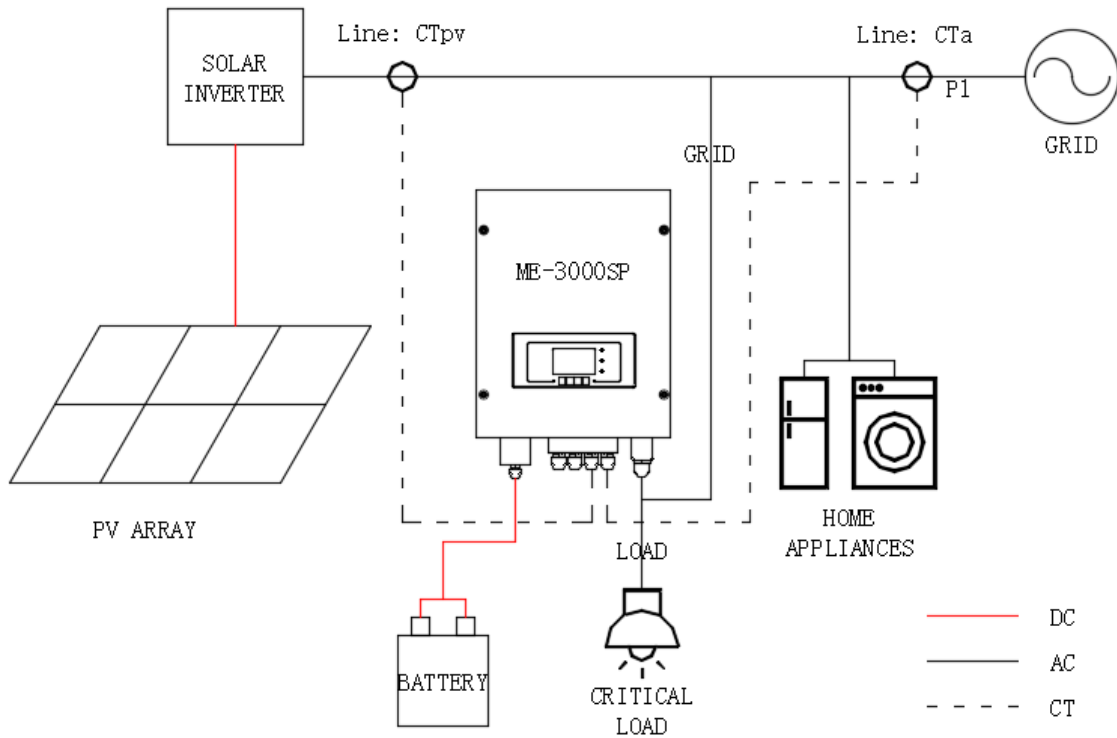

Fig. 10 Schematic Diagram (ME 3000SP: energy storage add-on to existing renewable system)

Step 1: Location of CTa: L wire of incoming mains. Location of CTpv: L wire of PV inverter's output.

Step 2: Use network cable & terminal caps to extend CT wires.

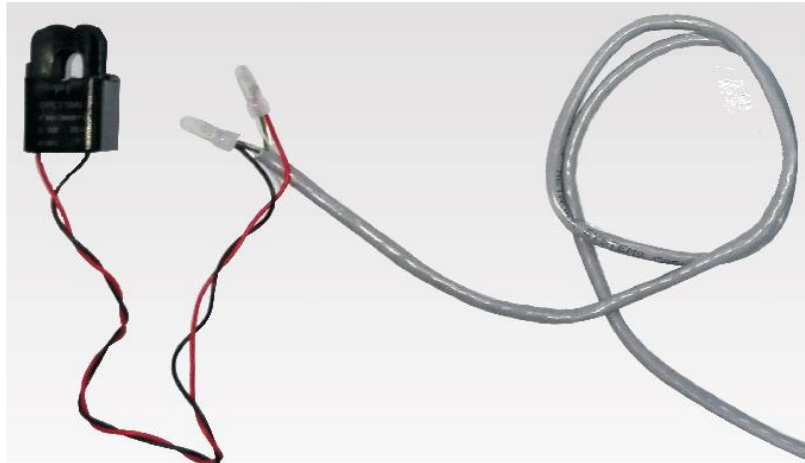

Fig. 11 CT wire extension

CT wire	Extension cable (network cable)	ME 3000SP
Red	Orange / white orange / brown / white brown	CT+
Black	Green / white green / blue / white blue	CT-

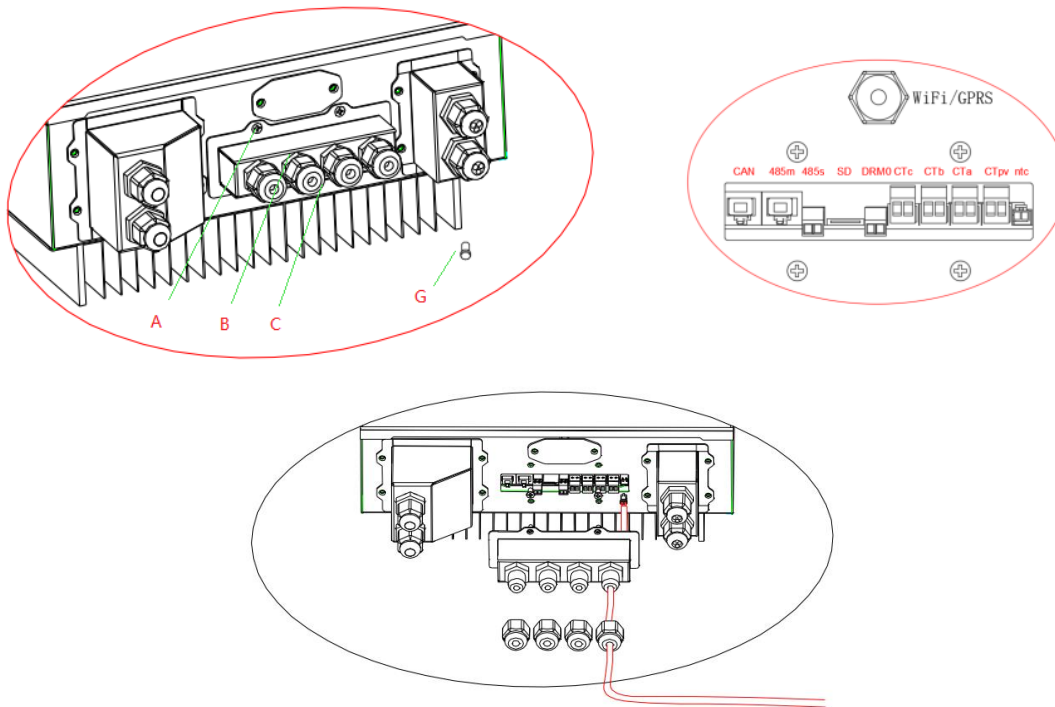

Fig. 12 CT / RS485 / NTC connection



Step 3: Loosen 4 screws (part A) using a screwdriver (fig. 13)

Step 4: Remove the waterproof cover (part B), loosen the cable gland (part C), then remove the stopper (part G)

Step 5: Route CT cable through the cable gland, connect CT cable to CT terminal, then insert CT terminal into corresponding ports.

Step 6: One communication cable is provided in the ME3000SP accessory bag. One inverter end, one BAT end.

Route the communication cable (inverter end) through the cable gland, insert the 4P4C connector to ME3000SP CAN port. Insert the 8P8C connector (BAT end) to PYLONTECH battery CAN port.

Communication cable between battery & ME3000SP	CAN communication
	<p>ME3000SP CAN port</p>
	<p>PYLONTECH US2000 PLUS / US2000B CAN port</p> <p>Note: Please confirm with representative of PYLONTECH that your battery is compatible with ME3000SP</p>

Step 7: Connect NTC for lead acid batteries only:

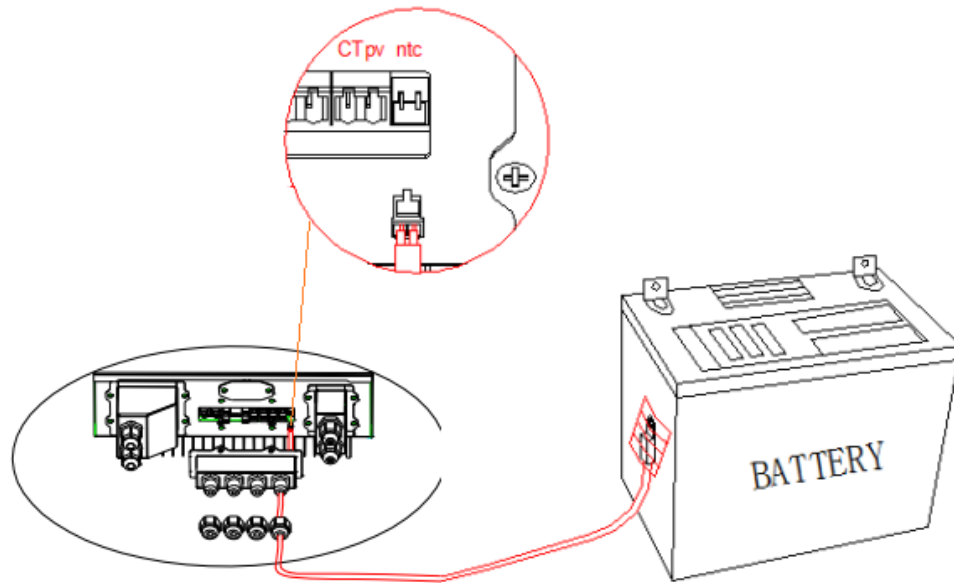

Fig. 13 NTC connection

Step 7: Fasten the waterproof cover using 4 screws.

4.4 Grid Connection

For most customers, please ONLY connect GRID port & leave LOAD port unconnected.

Unless you need the EPS (Emergency Power Supply) function.

Step 1: Loosen 4 screws (part A) using a screwdriver (fig. 14)

Step 2: Remove the waterproof cover (part B), loosen the cable gland (part C), then remove the stopper (part G)

Step 3: Route a 3-core cable through GRID cable gland, then connect 3 wires to corresponding terminal blocks. (BROWN – L, BLUE – N, YELLOW/GREEN – PE)

Step 4: Fasten the waterproof cover using 4 screws.

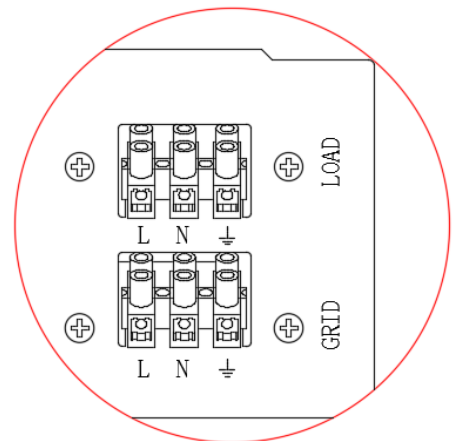

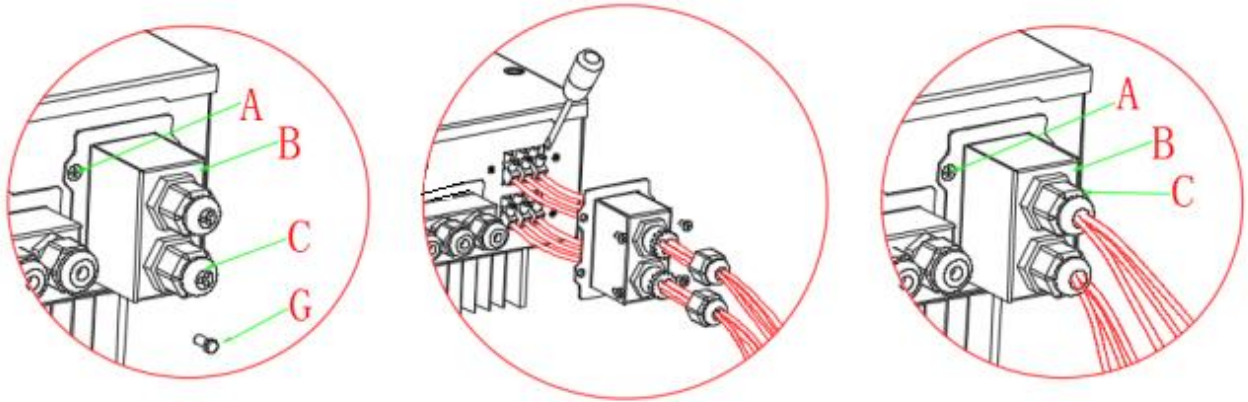

Fig. 14 Grid & Load connection

4.5 Critical Load Connection (EPS function)

Critical load: in case of grid outage, if EPS function is enabled, ME 3000SP will work in EPS (Emergency Power Supply) mode, discharge the battery & supply power to critical load via LOAD port.

LOAD port is only for critical load connection. Please make sure you've purchased the AC contactor from Shenzhen SOFARSOLAR Co., Ltd.

The connection procedure of LOAD port is the same as grid connection (Fig. 15).

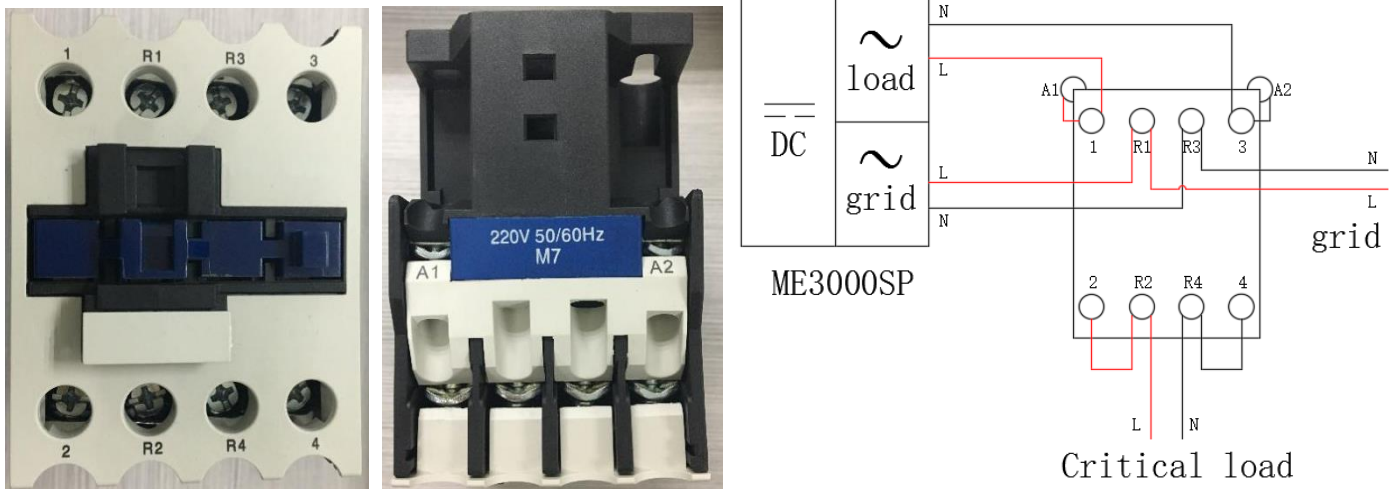

Fig. 15 AC contactor front view, top view, and connection

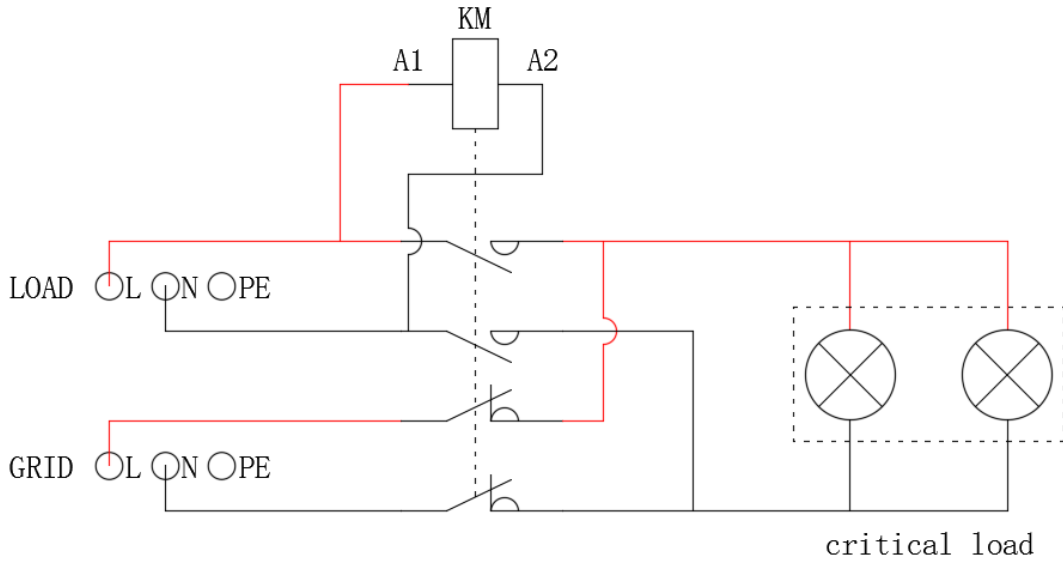

Fig. 16 Critical load connection (AC contactor: 2 NC, 2 NO)

4.6 WIFI/GPRS module installation procedure:

Step 1: Remove WIFI/GPRS waterproof cover using screw driver.

Step 2: Install WIFI/GPRS module.

Step 3: Fasten WIFI/GPRS module using screws.

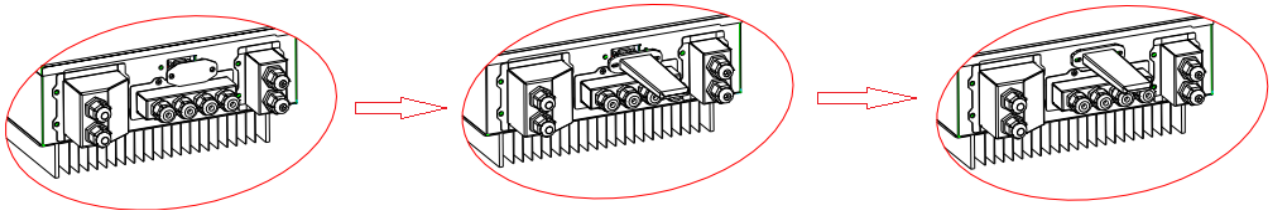

5. Buttons and indicator lights

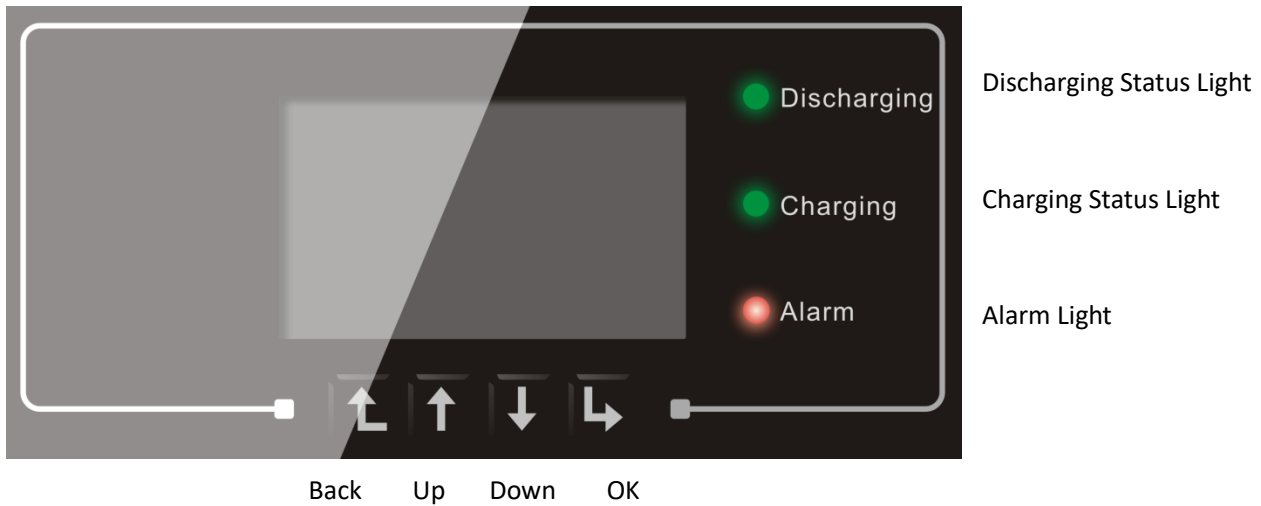

Fig 17. Buttons and indicator lights

5.1 Buttons:

- press “Back” to the previous screen or enter the main interface;
- press “Up” to the upper menu option or value plus 1;
- press “Down” to the lower menu option or value minus 1;
- Press “OK” to select the current menu option or switch to the next digit.

5.2 Indicator lights:

- Discharging status Light (Green)
 - Discharging light ON: discharging the battery
- Charging status Light (Green)
 - Charging light ON: charging the battery
- Alarm light (Red)

Alarm light ON: there’re some events in current event list.

5.3 Status of ME3000SP

Status of ME3000SP	Discharging Green light	Charging Green light	Alarm Red light
Discharge	ON		
Check discharge	Flashing		
Charge		ON	
Check charge		Flashing	
Standby	Flashing	Flashing	
EPS state	ON	ON	
Some events in current event list			ON

6. Operation

6.1 Double Check

Please double check the following before operation.

1. ME3000SP is firmly fastened to the mounting bracket on the wall;
2. The polarity of battery wires is correct, battery wires are firmly connected;
3. DC isolator is correctly connected between battery & ME3000SP, DC isolator: OFF;
4. GRID / LOAD cables are firmly / correctly connected;
5. AC circuit breaker is correctly connected between ME3000SP GRID port & GRID, AC circuit breaker: OFF;
6. AC contactor (if present) is correctly connected (fig. 12);
7. For lithium battery, please ensure that the communication cable has been correctly connected;
8. For the lead-acid battery, please ensure that the NTC wire has been correctly connected.

6.2 First Time Setup (IMPORTANT!)

IMPORTANT: PLEASE FOLLOW THE FOLLOWING PROCEDURE to switch ON ME3000SP

1. Make sure there's no power generation in ME3000SP's phase. (Turn OFF PV inverter.)
2. Switch on the battery. Turn ON DC isolator between battery & ME3000SP.
3. Turn ON AC circuit breaker between ME3000SP GRID port & GRID.
4. ME3000SP should start to operate now.

You need to set the following parameters before ME3000SP start to operate.

1)Set system time	8)*Set min discharge voltage
2)Set country	9)*Set max discharge current
3)Select battery type	10)*Set min protect voltage
4)*Set battery capacity	11)*Set discharge depth
5)*Set max charge voltage	12)*Set empty discharge voltage
6)*Set max charge current	13)*Set full charge voltage
7)*Set max protect voltage	

Note: 4) * to 13) * settings are only for DEFAULT battery type.

1)Set system time

System time format is “20YY-MM-DD-HH-MM-SS”, press “Up” or “Down” to change the 1st digit, press “OK” to switch to next digit, press “Ok” to complete setting. When system time setting is complete, “Set country” will pop up.

2)Set country

Press “Up” or “Down” to select a country, press “Ok” to complete the country setting. When country setting is complete, “Set battery type” will pop up.

Code	Country	Code	Country	Code	Country
00	Germany VDE4105	14	Germany VDE0126	28	Brazil
01	CEI-021 Internal	15	CEI-016 Italia	29	Slovakia VSD
02	Australia	16	UK G98	30	Slovakia SSE
03	SpainRD1699	17	Greece island	31	Slovakia ZSD
04	Turkey	18	EU EN50438	32	CEI0-21 In Areti
05	Denmark	19	IEC EN61727	33	Ukraine
06	Greece Continent	20	Korea	34	Brazil LV
07	Netherland	21	Sweden	35	Mexio LV
08	Belgium	22	Europe General	36	FAR Arrete32
09	UK G99	23	CEI-021 External	37	Denmark TR322
10	China	24	Cyprus	38	Wide-Range-60HZ
11	France	25	India	39	Ireland EN50438
12	Poland	26	Philippines		
13	Germany BDEW	27	New Zealand		

Note: different distribution network operators in different countries have different requirements regarding grid connections of battery storage inverters.

Therefore, it’s very important to make sure that you have selected the correct country code according to requirements of local authority.

Please consult qualified electrical engineer or personnel from electrical safety authorities about this.

Shenzhen SOFARSOLAR Co., Ltd. is not responsible for any consequences arising out of incorrect country code selection.

3)Select battery type

Press “Up” or “Down” to select your battery type, then press “Ok” to complete the battery type setting.

If you're using "1. PYLON", "2. DARFON", "4. General Lithium", "5. Alpha. ESS" & "6. SOLTARO" battery types, congratulations, ME3000SP's first time setup is complete. Please press "OK" to enter the main interface.

But if you're using "3. DEFAULT" battery type. We need more information regarding your battery.

MENU	Compatible Batteries
1.PYLON	PYLONTECH US2000 PLUS / US2000B Note: Please confirm with representative of PYLONTECH that your battery is compatible with ME3000SP
2. DARFON	DARFON 14S31P ESS
3.DEFAULT	LEAD ACID / LEAD CRYSTAL / AQUION battery
4. General Lithium	All batteries that comply with SOFAR'S BMS CAN communication protocol.
5. Alpha. ESS	M48112-P / SMILE-BAT
6. SOLTARO	SL-3KWH / SL-1KWH

4)*Set battery capacity (only for DEFAULT battery type)

Press "Up" or "Down" to change the 1st digit, press "OK" to switch to next digit. After changing the battery capacity per your battery specification, press "Ok", then "Set max charge voltage" will pop up.

5)*Set max charge voltage (only for DEFAULT battery type)

Press "Up" or "Down" to change the 1st digit, press "OK" to switch to next digit. After changing max charge voltage per your battery specification, press "Ok", then "Set max charge current" will pop up.

6)*Set max Charge current (only for DEFAULT battery type)

Press "Up" or "Down" to change the 1st digit, press "OK" to switch to next digit. After changing the max charge current per your battery specification, press "Ok", then "Set max protect voltage" will pop up.

7)*Set max protect voltage (only for DEFAULT battery type)

Press "Up" or "Down" to change the 1st digit, press "OK" to switch to next digit. After changing the max protect voltage per your battery specification, press "Ok", then "Set min discharge voltage" will pop up.

8)*Set min discharge voltage (only for DEFAULT battery type)

Press “Up” or “Down” to change the 1st digit, press “OK” to switch to next digit. After changing the min discharge voltage per your battery specification, press “Ok”, then “Set max discharge current” will pop up.

9)*Set max discharge current (only for DEFAULT battery type)

Press “Up” or “Down” to change the 1st digit, press “OK” to switch to next digit. After changing the max discharge current per your battery specification, press “Ok”, then “Set min protect voltage” will pop up.

10)*Set min protect voltage (only for DEFAULT battery type)

Press “Up” or “Down” to change the 1st digit, press “OK” to switch to next digit. After changing the min protect voltage per your battery specification, press “Ok”, then “Set discharge depth” will pop up.

11)*Set discharge depth (only for DEFAULT battery type)

Press “Up” or “Down” to change the 1st digit, press “OK” to switch to next digit. After changing the discharge depth per your battery specification, press “Ok”, then “Set empty discharge voltage” will pop up.

12)*Set empty discharge voltage (only for DEFAULT battery type)

Press “Up” or “Down” to change the 1st digit, press “OK” to switch to next digit. After changing the empty discharge voltage per your battery specification, press “Ok”, then “Set full charge voltage” will pop up.

13)*Set full charge voltage (only for DEFAULT battery type)

Press “Up” or “Down” to change the 1st digit, press “OK” to switch to next digit. After changing the full charge voltage per your battery specification, press “Ok”.

Congratulations, ME3000SP’s first time setup is complete. Please press “OK” to enter the main interface.

- 1) Turn ON some home appliances.
- 2) Make sure the electricity consumption in ME3000SP’s phase is greater than 200W. “Grid import power” shall equal “Home Consumption” now. (fig 15)
- 3) Turn ON PV inverter. “PV Production” shown on ME3000SP shall equal total power generation in ME3000SP’s phase now. (fig 15)

6.3 Commissioning

The main interface:

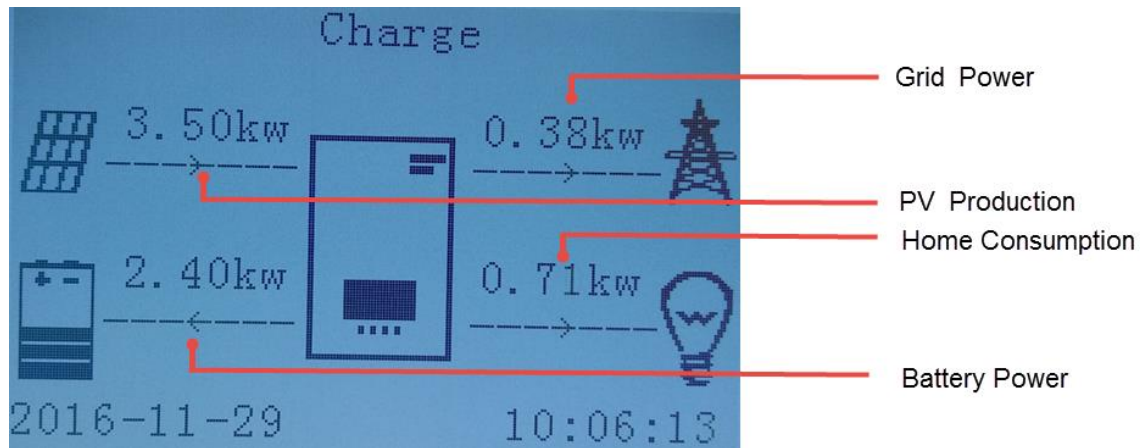

Fig 15. Screen of ME3000SP

If you didn't change the work mode of ME3000SP, which means ME3000SP is working in "Auto Mode":

While "PV Production" > "Home Consumption" (fig 15)

If the battery is not full. ME3000SP will charge the battery.

While "PV Production" < "Home Consumption" (fig 15)

If the battery is not flat. ME3000SP will discharge the battery.

Every time you change the CT connection, you need to restart ME3000SP. Please follow the following procedure:

1. Turn OFF PV inverter. Turn ON some home appliances.
2. Turn OFF AC circuit breaker (grid) / DC isolator (battery). Wait 5 minutes.
3. Turn ON DC isolator (battery), then turn ON AC circuit breaker (grid). Wait 1 minute.
4. Turn ON PV inverter.

6.4 Menu

In the main interface, press “back” button to enter main menu. The main menu has the following five options:

Main Interface	Press “Back”
“Up” ↑	1.Enter Setting
	2.Event List
	3.System Information
“Down” ↓	4.Software Update
	5.Energy Statistic

6.4.1 Enter setting:

1.Enter Setting	Press “OK”	
“Up” ↑	1.Battery Parameter	9.Set EPS Mode
	2.Clear Energy Data	10. DRMs0 Control
	3.Clear Events	11. Auto Test (For Italian Market Only)
“Down” ↓	4.Set Country	12. Work Mode Set
	5.Set Communication	13. CTpv Scale Facto
	6.Function to Set Country	14.CT Direction
	7.Set Language	15. Safety Param. Settings
	8.Set Time	16.CT Calibration

1. Battery Parameter

1.Battery Parameter		
“Up” ↑	1.Battery Type	7.Max. Discharge (A)
	2*. Battery Capacity	8*. Low (V) Protection
	3.Discharge Depth	9.Min. Discharge (V)
“Down” ↓	4.Max. Charge (A)	10*. Empty Discharged (V)
	5.Over (V) Protection	11*. Full Charged (V)

6.Max Charge (V)	12.Save
------------------	---------

Note: 2*/8*/10*/11* settings are only for DEFAULT battery type.

Select “1. Battery Parameter” and press “OK”, “input password” is shown. Input the password (normal “0001”, advanced “0715”), press “Up” or “Down” to change the 1st digit, press “OK” to switch to next digit, when “0001 / 0715” is shown on the screen, press “OK” to enter “Battery Parameter” interface. If “Incorrect, Try Again!” is shown on the screen, press “Back” and input the password again.

1) Battery Type (refer to [Set battery type](#))

Select “1. Battery Type” and press “OK”. Press “up” or “down” to select the battery type. Press “OK”.

2) * Battery Capacity (only for DEFAULT battery type)

Select “2. Battery Capacity” and press “OK”. Press “up” or “down” to change the 1st digit, press “ok” to switch to next digit. Input the value of battery capacity. Press “OK”.

3) Discharge Depth

Select “3. Discharge Depth” and press “OK” to enter discharge depth interface.

Discharge Depth	50%
EPS Discharge Depth	80%

Press “up” or “down” to change the 1st digit, press “ok” to switch to next digit. Input the value of Discharge Depth & EPS Discharge Depth per battery specification. Press “OK”.

For example: if Discharge Depth = 50% & EPS Discharge Depth = 80%.

While electric grid is connected: ME3000SP won’t discharge the battery when its SOC is less than 50%.

In case of blackout: ME3000SP will work in EPS mode (if EPS mode is enabled) & keep discharging the battery till battery SOC is less than 20%.

4) Max. Charge (A)

Select “4. Max. Charge (A)” and press “OK”. Press “up” or “down” to change the 1st digit, press “ok” to switch to next digit. Input the value of Max. Charge (A) per battery specification. Press “OK”.

5) Over (V) Protection

Select “5. Over (V) Protection” and press “OK. Press “up” or “down” to change the 1st digit, press “ok” to switch to next digit. Input the value of Over (V) Protection per battery specification. Press “OK”.

6) Max. Charge (V)

Select “6. Max. Charge (V)” and press “OK”. Press “up” or “down” to change the 1st digit, press “ok” to switch to next digit. Input the value of Max. Charge (V) per battery specification. Press “OK”.

7) Max. Discharge (A)

Select “7. Max. Discharge (A)” and press “OK”. Press “up” or “down” to change the 1st digit, press “ok” to switch to next digit. Input the value of Max. Discharge (A) per battery specification. Press “OK”.

8) * Low (V) Protection (only for DEFAULT battery type)

Select “8. Low (V) Protection” and press “OK”. Press “up” or “down” to change the 1st digit, press “ok” to switch to next digit. Input the value of Low (V) Protection per battery specification. Press “OK”.

9) Min. Discharge (V)

Select “6. Min. Discharge (V)” and press “OK”. Press “up” or “down” to change the 1st digit, press “ok” to switch to next digit. Input the value of Min. Discharge (V) per battery specification. Press “OK”.

10) * Empty Discharged (V) (only for DEFAULT battery type)

Select “10. Empty Discharged (V)” and press “OK”. Press “up” or “down” to change the 1st digit, press “ok” to switch to next digit. Input the value of Empty Discharged Voltage per battery specification. Press “OK”.

11) * Full Charged (V) (only for DEFAULT battery type)

Select “11. Full Charged (V)” and press “OK”. Press “up” or “down” to change the 1st digit, press “ok” to switch to next digit. Input the value of Full Charged Voltage per battery specification. Press “OK”.

12) Save

Select “12. Save” and press “OK” to save all battery parameters.

2. Clear Energy Data

Select “2. Clear Energy” and press “OK”, “input password” is shown. Input the password “0001”, press “Up” or “Down” to change the 1st digit, press “OK” to switch to next digit, when “0001” is shown on the screen, press “OK”. If “Incorrect, Try Again!” is shown on the screen, press “Back” and input the password again.

3. Clear Events

Select “3. Clear Events”, press “OK” button twice to clear all the events.

4. Set Country (refer to [Set country](#))

Select “4. Set Country”, press “OK”, current country setting is shown, input new country code & press “OK”

If “Set Disable” is shown, you need to go to “6. Function to Set Country” to enable country setting first.

5. Set Communication

Select “5.Set Communication”, press “OK” to enter autotest interface.

5.Set Communication	Press “Back”
	1.Communication Addr.
“Up” ↑	2.Baudrate
	3.Databits
“Down” ↓	4.Parity
	5.Stopbits

1) Communication Addr.

Select “1. Communication Addr.”, then press “OK” to Set Communication Addr. , press “Up” or “Down” to change

the 1st digit, press “OK” to switch to next digit, and press “OK”.

2) Baudrate

Select “2. Baudrate”, then press “OK” to Set Baudrate, press “Up” or “Down” to change Baudrate and press “OK”.

3) Databits

Select “3. Databits”, then press “OK” to set Databits, press “Up” or “Down” to change Databits and press “OK”.

4) Parity

Select “4. Parity”, then press “OK” to set Parity, press “Up” or “Down” to select EVEN、ODD or NONE, and press “OK”.

5) Stopbits

Select “5. Stopbits”, then press “OK” to set Stopbits, press “Up” or “Down” to change Stopbits and press “OK”.

6. Function to Set Country

Select “6. Function to Set Country”, press “OK”, “input password” is shown. Input the password “0001”, press “Up” or “Down” to change the 1st digit, press “OK” to switch to next digit, when “0001” is shown on the screen, press “OK”. If “Incorrect, Try Again!” is shown on the screen, press “Back” and input the password again.

7. Set Language

Select “7. Set Language”, press “OK”. Press “up” or “down” to select the language and press “OK”.

Easier Way: press “Back” & “OK” at the same time to change system language.

8. Set Time

Select “8. Set Time”, press “OK” to enter time setting interface, system time format is 20YY-MM-DD HH:MM:SS. Press “Up” or “Down” to change the 1st digit, press “OK” to switch to next digit, after inputting the current time, press “OK”.

9. Set EPS (Emergency Power Supply) Mode

10. Set EPS Mode	1. EPS Mode Control	1. Enable EPS Mode
		2. Disable EPS Mode
	2. Set EPS Changeover Time	***S

10. Logic interface

Select “10. Logic interface”, press “OK”, “input password” is shown. Input the password “0001”, press “Up” or “Down” to change the 1st digit, press “OK” to switch to next digit, when “0001” is shown on the screen, press “OK”. Then press “up” or “down” to select “1. Enable” or “2. Disable”, press “OK”.

11. Auto Test (ONLY for Italian Market)

Select "11. Auto Test", press "OK" to enter autotest interface.

11.Auto Test	1.Autotest Fast
"Up" ↑	2.Autotest STD
	3.QF Time Setting
"Down" ↓	4.QV Time Setting
	5.Control 81.S1

1) Autotest Fast

Select "1. Autotest Fast", then press "OK" to start Auto test Fast.

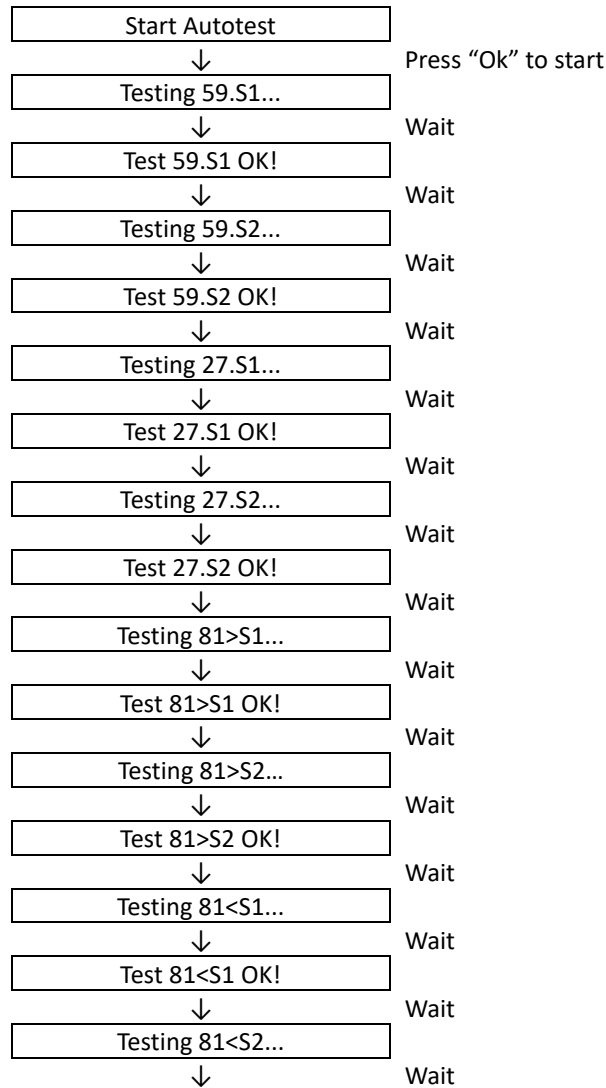

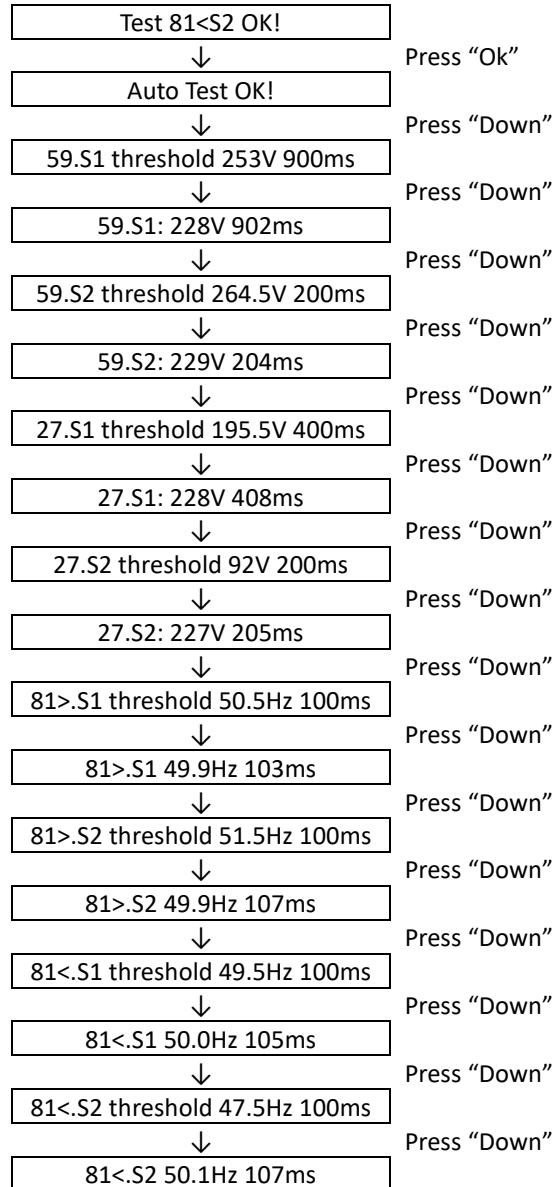

2) Autotest STD

Select "2. Autotest STD", then press "OK" to start Auto test STD.

The test procedure is same as Autotest Fast, but it's much more time consuming.

3) PF Time Setting

Select "3. PF Time Setting", then press "OK". The following will be shown on the display:

Set: *. *** s

Press "Up" or "Down" to change the 1st digit, press "OK" to switch to next digit. After changing all digits, press

“OK”.

4) QV Time Setting

Select “4. QV Time Setting”, then press “OK”. The following will be shown on the display:

Set: ** s

Press “Up” or “Down” to change the 1st digit, press “OK” to switch to next digit. After changing all digits, press “OK”.

5) Control 81.S1

Select “5.Control 81.S1”. then press “OK”. Press “up” or “down” to select “1. Enable 81.S1” or “2. Disable 81.S1”, press “OK”.

12. Work Mode Set

Select “12. Work Mode Set”, press “OK” to enter work mode setting interface.

12.Work Mode Set	
“Up” ↑	1.Set Auto Mode
	2.Set Time-of-use Mode
“Down” ↓	3.Set Timing Mode
	4.Set Passive Mode
	5. Peak Shaving Mode

1) Set Auto Mode

Select “1. Set Auto Mode”, then press “OK”.

In auto mode, ME3000SP will automatically charge & discharge the battery.

1) PV generation \approx LOAD consumption ($\Delta P < 100W$), ME3000SP will stay in Standby state.	2) PV generation $>$ LOAD consumption, the surplus power will be stored in the battery.
---	---

<p>3) When the battery is full(or already at Max Charge Power), excess power will be exported to the grid.</p>	<p>4) PV generation < LOAD consumption, ME3000SP will discharge the battery to supply power to load,</p>
<p>5) If PV generation + Battery < LOAD consumption, ME3000SP will import power from the grid.</p>	<p>6) Press “DOWN” button to check current detailed information, press “UP” to get back to main interface.</p>
	<pre> Vgrid:..... 230.2V Igrid:..... 7.85A Frequency:..... 50.01Hz Bat Voltage:..... 48.2V Bat CurCHRG:..... 0.00A Bat CurDisC:..... 39.86A Bat Capacity:..... 52% Bat Cycles:..... 0000T Bat Temp:..... 25°C </pre>

2) Set Time-of-use Mode

Select “2. Set Time-of-use Mode”, and then press “OK” to enter Set Time-of-use mode interface.

Set Time-of-use Mode			
Rules. 0: Enabled			
From	To	SOC	Charge
02h00m	- 04h00m	070%	1000W
Effective date			
Dec. 22 - Mar. 21			
Weekday select			
Mon. Tue. Wed. Thu. Fri. Sat. Sun.			

If electricity is more expensive in high demand time (peak rate) & electricity is much cheaper in low demand time (off-peak rate).

You can select an off-peak period to charge your battery. Outside the off-peak charge period, ME3000SP is working in Auto Mode.

If your family normally go to work/school on weekdays & stay at home on weekends, which means the home electricity consumption is much higher on weekends. Thus, you need to store some cheap electricity on weekends only. This is possible using our Time-of-use mode.

In summer, if your PV system can produce more electricity than your home electricity consumption. Then you don't need to set an off-peak charge period to charge your battery in summer at all. You can select an effective date (normally winter) for Time-of-use mode in this case. Outside the effective date, ME3000SP is working in Auto Mode.

You can set multiple Time-of-use rules to meet your more complex requirement. Right now we support 4 rules maximum (rule 0/1/2/3).

3) Set Timing Mode

Select "3. Set Timing Mode", and then press "OK" to enter Set Timing mode interface. The interface of Set Timing Mode is shown as below. You can select a charge time/power & discharge time/power in this mode.

Note: normally this mode is used to test whether ME3000SP can charge & discharge correctly or not. So basically, this mode is used for testing purposes only.

Charge Start	22 h 00 m
Charge End	05 h 00 m
Charge Power	2000 W
DisCharge Start	14 h 00m
DisCharge End	16 h 00m
DisCharge Power	2500 W

4) Set Passive Mode

Select “4. Set Passive Mode”, and then press “OK”.

For more detailed information, please ask representative of SOFAR to get a copy of passive mode communication protocol.

5) Peak Shaving Mode

Select “5. Peak Shaving Mode”, then press “OK” to enter Peak Shaving Mode.

Peak Shaving Mode
Charge Threshold
0100W
Discharge Threshold
0100W

In this interface, we can set charge and discharge threshold power and the threshold power range is 100W to 2500W. If PV generation is greater than the sum of load consumption and the charge threshold power, the inverter will keep the grid power that is equal to the charge threshold power. The surplus power will be stored in the battery. If PV generation is greater than the sum of load consumption and the charge threshold power and the battery charging power, the surplus power will feed back into the grid. If load consumption is greater than the sum of PV generation and the discharge threshold power, the inverter will keep the grid power that is equal to the discharge threshold power and the battery will supply the insufficient energy. If load consumption is greater than the sum of PV generation and the charge threshold power and the battery discharging power, the grid will supply the insufficient energy.

13. CTpv Scale Factor

Select “13. CTpv Scale Factor”, press “OK”, “input password” is shown. Input the password “0001”, press “Up” or “Down” to change the 1st digit, press “OK” to switch to next digit, when “0001” is shown on the screen, press “OK”. According to the PV actual quantity, press “Up” or “Down” to select the correct value and press “OK”.

14. CT Direction

Select “13. CTpv Scale Factor”, press “OK”, “input password” is shown. Input the password “0001”, press “Up” or “Down” to change the 1st digit, press “OK” to switch to next digit, when “0001” is shown on the screen, press “OK”. In this interface, press “Up” or “Down” to select FREEZE or UNFREEZE. If you select FREEZE, CT directioning will be frozen. When you restart the inverter, CT directioning will stay the same. If you select UNFREEZE, CT directioning won't be frozen. When you restart the inverter, CT directioning will be recalibrated again.

15. Safety Param. Settings

Select “13. Safety Param. Settings”, press “OK”, “input password” is shown. Input the password “0001”, press “Up” or “Down” to change the 1st digit, press “OK” to switch to next digit, when “0001” is shown on the screen, press “OK”.

Copy the TXT file to the root directory of SD card, Press “up” or “down” to select “1. Set START Parameters”, “2. Set Safety Voltage” or “3. Set Safety Frequency”, press “OK”. Please contact SOFAR technical support for more information.

16.CT Calibration

Its function is to calibrate grid-connected power.

Select “10. CT Calibrate ”, press “OK”, “input password” is shown. Input the password “0001”, press “Up” or “Down” to change the 1st digit, press “OK” to switch to next digit, when “0001” is shown on the screen, press “OK”.Then input the actual power minus the difference of LCD display grid-connected power.

6.4.2 Event List

2.Event List	
“Up” ↑	1.Current Event List
“Down” ↓	2.History Event List

Event list of ME 3000SP, including current event list and history event list.

1) Current Event List

Select “1. Current Event List”, press “OK” to check the current events.

2) History Event List

Select “2. History Event List”, press “OK” to check the history events. Press “up” or “down” to check all history events if there’re more than 1 page of events.

6.4.3 System information interface

The following information will be shown in 3. System Information

3.System Information	
	System Information (1)
	Product SN
	Software Version
	Hardware Version
	RS485 Address

System Information (2)	Country
	EPS Mode
	Work Mode
System Information (3)	DRMs0 Control
	PF Time Setting
	QV Time Setting
	Power Factor
System Information (4)	CTpv Scale Factor
	CT Direction
Battery Parameter (1)	Battery Type
	Battery Capacity
	Discharge Depth
	Max Charge (A)
Battery Parameter (2)	Over (V) Protection
	Max Charge (V)
	Max Discharge (A)
	Min Discharge (V)

6.4.4 Software upgrade

Copy the upgrade firmware to the root directory of SD card.

(Note: Ask SOFAR technical support for upgrade firmware & instruction.)

Select "4. Software Update", press "OK", "input password" is shown. Input the password ("0715"), press "Up" or "Down" to change the 1st digit, press "OK" to switch to next digit, when "0715" is shown on the screen, press "OK". ME 3000SP will start to upgrade the software automatically.

Detailed Firmware Upgrade Procedure:

Step 1 Turn off AC circuit breaker (grid) and DC isolator (battery), then remove communication waterproof cover. If communication cables (RS485/NTC/CT) have been connected, loosen their cable glands before removing cover.

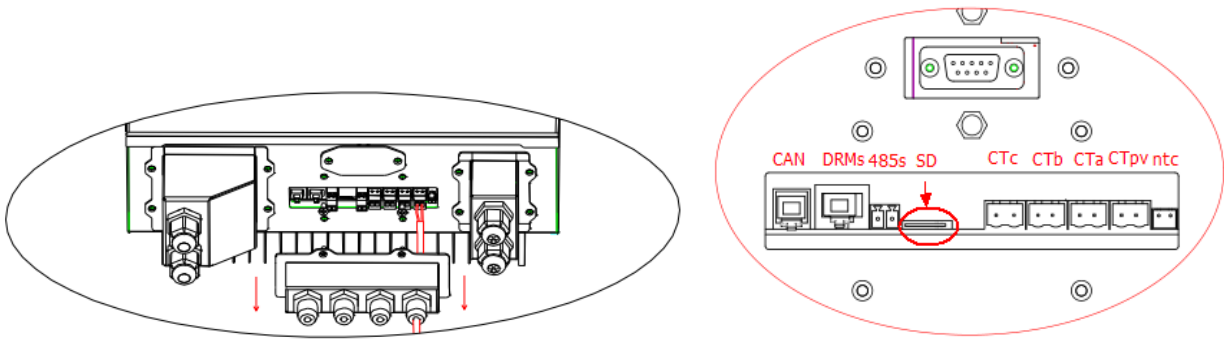

Step 2 Press the SD card and take it out. Insert the SD card into a micro-SD card reader, then insert micro-SD card reader into a PC; (NOTE: micro-SD card reader & PC are not provided by SOFARSOLAR).

Step 3 Format the SD card. Copy the “ES3000firmware” folder to the SD card.

Step 4 Insert the SD card back to the SD card slot.

Step 5 Then turn on DC isolator (battery), wait 5 seconds, turn on AC circuit breaker (grid), press “Back” to enter main menu. Press “Down” to select “4. Software Update”, then press “Ok”.

Step 6 “Input password” is shown. Input the password (“0715”), press “Up” or “Down” to change the 1st digit, press “OK” to switch to next digit, when “0715” is shown on the screen, press “Ok” to start firmware update.

Step 7 After finishing firmware upgrade, turn off AC circuit breaker (grid) and DC isolator (battery), lock the communication waterproof cover with four screws, then turn on DC isolator (battery), wait 5 seconds, turn on AC circuit breaker (grid), ME 3000SP will start to operate automatically.

NOTE: If “DSP communicate fail”, “Update DSP1 Fail” or “Update DSP2 Fail” is shown on the screen, which means the firmware upgrade is unsuccessful, please turn off AC circuit breaker (grid) and DC isolator (battery), wait 5 minutes, then start again from “Step 5”.

6.4.5 Energy Statistic:

5. Energy Statistics		
	Today	
Renewable	100.00KWh	
Self-Use	80.00KWh	80%
Export	20.00KWh	20%
Load	100.00KWh	
Self-Use	80.00KWh	80%
Import	20.00KWh	20%

Select “5. Energy Statistic”, press “OK” to enter Energy Statistic interface, it shows the energy generation and

consumption within a certain range of time. Press “Up” or “Down” to check the daily / weekly / monthly / yearly / lifetime energy statistics.

7. Technical Data

Model	ME3000SP
Battery Parameters	
Battery Type	Lead-acid, Lithium-ion
Nominal battery voltage	48V
Battery voltage range	42 - 58V
Recommended battery capacity	200Ah (100 – 500 Ah optional)
Recommended storage capacity	9.6 kWh
Max charge current	60A
Charge current range	0 – 60A programmable
Charge curve	3 - stage adaptive with maintenance
Max discharge current	65A
Battery protection	Over voltage protection / Over current protection / Over temperature protection
Short circuit protection	100A fuse
Depth of discharge	Lithium: 0 – 85% DOD adjustable
	Lead acid: 0 –90% DOD adjustable
AC parameters	
Max output power	3KVA single phase
Max output current	13A
Nominal grid voltage & frequency	230V, 47 – 53Hz or 57 – 63Hz
AC voltage range	150 – 275V (according to local authority requirements)
THDi	<3%
Power factor	1 (+ / - 0.8 adjustable)
Inrush current	0.8A / 1us
Max output fault current	100A / 1us
System parameters	
Max efficiency	Charge: 94.1% / discharge 94.3%
Standby losses	< 5W
Topology	High frequency transformer isolated
Ingress protection ratings	IP 65
Safety protection	Anti-islanding, RCMU, ground fault monitoring
Communication	Wi-Fi, RS485

Environmental data	
Ambient temperature range	-25C to +60C (derating above +45C)
Relative humidity range	0% - 100% (no condensing)
Protective class	Class I
Max operating altitude	2000m
Current transformer connection	Hard wired
General data	
Noise	<25dB
Weight	16kg
Cooling	Natural convection
Dimensions (W*H*D)	532 x 360 x 173 mm
Display	LCD display
Warranty	5 years
EPS (Emergency Power Supply) data	
EPS rated power	3000VA
EPS nominal voltage/frequency	230V, 50/60Hz
EPS rated current	13A
THDi	<3%
Switch time	< 3s

8. Troubleshooting

Code	Name	description	solution
ID01	GridOVP	The power grid voltage is too high	<p>If the alarm occurs occasionally, the possible cause is that the electric grid is abnormal occasionally. ME3000SP automatically returns to normal operating status when the electric grid's back to normal.</p> <p>If the alarm occurs frequently, check whether the grid voltage/frequency is within the acceptable range. If no, contact SOFAR technical support. If yes, check the AC circuit breaker and AC wiring of the ME3000SP.</p> <p>If the grid voltage/frequency is within the acceptable range and AC wiring is correct, while the alarm occurs repeatedly, contact SOFAR technical support to change the grid over-voltage, under-voltage, over-frequency, under-frequency protection points after obtaining approval from the local electrical grid operator.</p> <p>If you confirm that AC wiring is correct & grid voltage/frequency is within acceptable range, the alarm still occurs repeatedly, try to <u>change country code</u> to 22. Then <u>restart</u> ME3000SP to see if problem is solved.</p>
ID02	GridUVP	The power grid voltage is too low	
ID03	GridOFP	The power grid frequency is too high	
ID04	GridUFP	The power grid frequency is too low	
ID05	BatOVP	The battery voltage is too high	<p>If the alarm occurs occasionally, the possible cause is during the process of charging.</p> <p>If the alarm occurs occasionally, check whether the overvoltage setting of the battery consistent with the parameter of battery manufacturer and contact SOFAR technical support.</p>
ID09	HW_LLCCBus_OVP	LLCCBus voltage is too high and has triggered hardware protection	<p>ID09- ID26 are internal faults of ME3000SP, turn OFF the DC isolator & AC circuit breaker, wait for 5 minutes, then turn ON the DC isolator and turn ON the AC circuit breaker. Check whether the problem is solved. If no, please contact SOFAR technical support.</p>
ID10	HW_Boost_OVP	Boost voltage is too high and has triggered hardware protection	

ID11	HwBuckBoostOCP	BuckBoost current is too high and has triggered hardware protection		
ID12	HwBatOCP	The battery current is too high and has triggered hardware protection		
ID15	HwAcOCP	The grid current is too high and has triggered hardware protection		
ID17	HwADFaultIGrid	The grid current sampling error		
ID18	HwADFaultDCI	The DCI sampling error		
ID19	HwADFaultVGrid	The grid voltage sampling error		
ID21	MChip_Fault	The master chip fault		
ID22	HwAuxPowerFault	The auxiliary voltage error		
ID25	LLCBusOVP	LLCBus voltage is too high		
ID26	SwBusOVP	Bus voltage is too high and has triggered software protection		
ID27	BatOCP	Battery current is too high		If the fault occurs frequently, please contact SOFAR technical support.
ID28	DciOCP	The DCI is too high		ID28-ID51 are internal faults of ME3000SP, turn OFF the DC isolator & AC circuit breaker, wait for 5 minutes, then turn ON the DC isolator and turn ON the AC circuit breaker. Check whether the problem is solved. If no, please contact SOFAR technical support.
ID29	SwOCPInstant	The grid current is too high		
ID30	BuckOCP	Buck current is too high		
ID31	AcRmsOCP	The output current is too high		
ID49	ConsistentFault_VGrid	The grid voltage sampling value between the master DSP and slave DSP is not consistent		
ID50	ConsistentFault_FGrid	The grid frequency sampling value between the master DSP and slave DSP is not consistent		
ID51	ConsistentFault_DCI	The Dci sampling value between the master DSP and slave DSP is not consistent		
ID52	BatCommunicationFlag	Battery communication fault	ME3000SP can't communicate with Lithium battery BMS correctly.	

			<p>Make sure the battery you're using is compatible with ME3000SP.</p> <p>Make sure you've selected the correct battery type. Check the communication cable between battery & ME3000SP.</p> <p>It's recommended to use CAN communication.</p> <p>For PYLONTECH US2000 PLUS battery, and you're using RS485 communication, the ADD DIP switch should be all down.</p>
ID53	SpiCommLose	SPI communication is fault	<p>ID53-ID77 are internal faults of ME3000SP, turn OFF the DC isolator & AC circuit breaker, wait for 5 minutes, then turn ON the DC isolator and turn ON the AC circuit breaker. Check whether the problem is solved. If no, please contact SOFAR technical support.</p>
ID54	SciCommLose	SCI communication is fault	
ID55	RecoverRelayFail	The relays fault	
ID57	OverTempFault_BAT	The battery temp is too high	
ID58	OverTempFault_HeatSink	The temperature of heat sink is too high	
ID59	OverTempFault_Env	The environment temp is too high	
ID65	unrecoverHwAcOCP	The grid current is too high and has cause unrecoverable hardware fault	
ID66	unrecoverBusOVP	The bus voltage is too high and has cause unrecoverable fault	
ID67	BitEPSunrecoverBatOcP	Unrecoverable fault of battery overcurrent in EPS mode	
ID70	unrecoverOCPIinstant	The grid current is too high, and has cause unrecoverable fault	
ID75	unrecoverEEPROM_W	The EEPROM is unrecoverable	
ID76	unrecoverEEPROM_R	The EEPROM is unrecoverable	
ID77	unrecoverRelayFail	Relay has happen permanent fault	
ID81	Over temperature	Internal temperature is too high.	

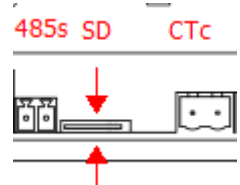
			3. Please make sure the inverter is vertically installed & the ambient temperature is less than the temperature upper limit of ME3000SP
ID82	Over frequency	AC frequency is too high	
ID83	Long dist Load Shedding	Long distance Load Shedding	ME3000SP receives a remote signal to decrease its power.
ID84	Long dist OFF	Switch OFF ME3000SP remotely	ME3000SP receives a remote signal to switch OFF.
ID85	SOC <= 1 -DOD or Battery voltage is low		For example, if you set DOD to 30%, when SOC is less than 70%, you will see ID85 in the event list. ME3000SP won't discharge the battery when ID85 is present. Or This is an indication of low battery voltage. ME3000SP won't discharge battery in this case to ensure long battery cycle life.
ID86	Bat Voltage Low Shut	Battery voltage is too low & cause ME3000SP to switch OFF	ME3000SP will switch OFF when battery voltage is too low. This is a protection for battery.
ID94	Software version is not consistent		Contact SOFAR technical support to upgrade software.
ID95	CommEEPROMFault	The Communication board EEPROM is fault	ID95-ID96 are internal faults of ME3000SP, turn OFF the DC isolator & AC circuit breaker, wait for 5 minutes, then turn ON the DC isolator and turn ON the AC circuit breaker. Check whether the problem is solved. If no, please contact SOFAR technical support.
ID96	RTCFault	RTC clock chip is fault	
ID98	SDfault	The SD card is fault	Normally ID98 is caused by loose SD card holder. Click & take out SD card, press SD card holder then insert SD card back can normally solve this problem. 

ID100	BatOCD	Battery over current discharging protect	ID100-ID103 is battery fault. If this fault occurs occasionally, wait few minutes to see whether the problem is solved. If this fault occurs frequently, please contact SOFAR technical support.
ID101	BatSCD	Discharging short circuit protect	
ID102	BatOV	Battery high voltage protect	
ID103	BatUV	Battery low voltage protect	
ID104	BatOTD	Battery high temperature protect while discharging	Make sure battery is in a well-ventilated place. Try to decrease the max discharge (A) or/and max charge (A) to see if the problem is solved.
ID105	BatOTC	Battery high temperature protect while charging	
ID106	BatUTD	Battery low temperature protect while discharging	Try to increase the ambient temperature of the battery.
ID107	BatUTC	Battery low temperature protect while charging	

9. Quality Assurance

The standard warranty period for SOFARSOLAR Inverter is 3/5/7/10 years which depends on the purchase agreement. Up to 12 months following the installation date or 18 months from the date of shipment (whichever date comes first) from SOFARSOLAR factory, the purchaser may apply for a warranty extension by providing the serial number of the unit. SOFARSOLAR may reject the application received which does not meet the date requirement. Extension warranty can be purchased for extra 5, 7, 10 or 12 years. For more details please check with SOFARSOLAR service team. Monitoring devices (WiFi card, Ethernet card, GPRS card, GPRS kit) are not included in the on-site service range, but SOFARSOLAR could provide remotely service and replacing service.

Disclaimer:

During the warranty period, SOFARSOLAR guarantees normal operation of the inverter. If during the warranty period, the inverter develops fault, please contact your installation contractor or supplier. In case of faults falling within manufacturers' responsibility, SOFARSOLAR will be responsible for maintenance or replacement. Any defect caused by the following circumstances will not be covered by the manufacturer's warranty (the Dealers or Distributors are responsible and authorized by SOFARSOLAR for the following investigation):

- Product modified, design changed or parts replaced not approved by SOFARSOLAR;
- Changes, or attempted repairs and erasing of series number or seals by non SOFARSOLAR technician;
- Incorrect installation, design or commissioning;
- Failure to comply with the local safety regulations (in Germany VDE standards for example.);
- The Product has been improperly stored and damaged while being stored by the Dealer or the end user;
- Transport damage (including painting scratch caused by movement inside packaging during shipping). A claim should be made directly to shipping company/ insurance company as soon as the container/ packaging is unloaded and such damage is identified;
- Failure to follow any/all of the user manual, the installation guide and the maintenance regulations;
- Improper use or misuse of the device;
- Insufficient ventilation of the device;
- The maintenance procedures relating to the product have not been followed to an acceptable standard;
- Damage because of external factors or Force majeure (violent or stormy weather, lightning, overvoltage, fire etc.).