

USE AND INSTALLATION MANUAL

# LANDBLOCK<sup>®</sup>

**SUPPORTS WITH WATER BALLAST**

FOR SOLAR SYSTEMS ON ROOFTOPS  
OR PASSABLE FLAT SURFACES

[landatusolar.com](http://landatusolar.com)

# Table of contents

<b>PRESENTATION</b>	<b>3</b>
<b>INTENDED USE</b>	<b>4</b>
<b>LANDBLOCK® MATERIALS</b>	<b>4</b>
<b>INSTALLATION IN JUST 4 STEPS</b>	<b>5</b>
Landblock® positioning	6
Installing connectors and panels	7
<b>USE WATER FOR BALLAST</b>	<b>11</b>
Fit the cover	11
<b>ANNEXE. SPECIFICATIONS FOR MIDDLE AND Z CONNECTORS</b>	<b>12</b>
<b>BASIC SAFETY AND MAINTENANCE</b>	<b>13</b>



Fast  
installation



Without  
perforating  
the rooftop



Without heavy  
machinery

 This use and installation manual must be followed for LANDBLOCK® installation.

# LANDBLOCK®

## SUPPORTS WITH WATER BALLAST THE BEST SOLUTION FOR SOLAR SYSTEMS!

LANDBLOCK® is a support with water ballast that is perfect for installing solar systems on any flat surface (rooftop, ground, etc.).

**Simplify solar panel installation with LANDBLOCK® and forget concrete supports.**

### Technical Information

Composition	HDPE
Support tilt angle	15°
Weight (without ballast)	3 kg
Dimensions	380 × 1150 × 480 mm
Units/pallet	100 units
Ballast capacity	56 L (water), more than 100 kg (gravel, sand, concrete...)

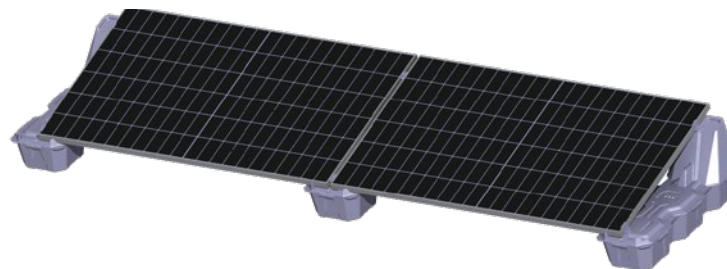
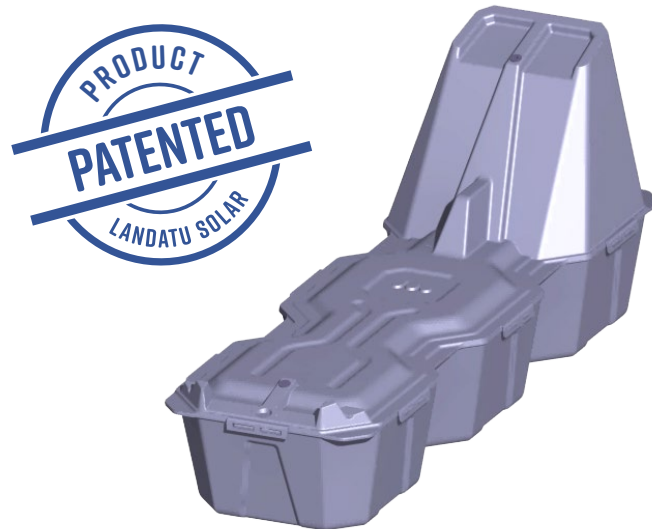

### Advantages

- ✓ Minimise costs and shorten installation time.
- ✓ Simplify everything:
  - ✗ No perforations
  - ✗ No foundation
  - ✗ No metal structures
  - ✗ No concrete
  - ✗ No heavy machinery
- ✓ Lightweight and stackable Get rid of heavy supports and lower transport and storage costs.
- ✓ LANDBLOCK® lets you adjust the ballast weight depending on the rooftop.
- ✓ Evaporation tests have been done that show the water doesn't evaporate.

# INTENDED USE







## Intended use

- ✓ LANDBLOCK® is designed exclusively for use on rooftops or flat surfaces (max. 5°).
- ✓ Different ballast materials, like water or gravel, can be used with the support depending on the project requirements.
- ✓ The solar panels are installed **horizontally** directly on the support using the connectors without having to assemble a metal or concrete structure.
- ✓ The complete support has a mass of 3 kg, so you DON'T need to use a forklift or other lifting device.
- ✓ The lugs on the LANDBLOCK® can be used to channel the electrical wiring in a safe organised way.

# LANDBLOCK® MATERIALS

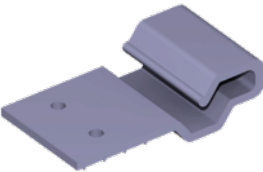
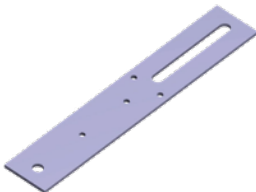
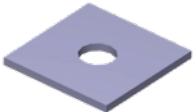

Included		Not included
 Cover	 Base	<ul style="list-style-type: none"><li>• ø4.5 mm screws (or ø4.8 mm pop rivets)</li></ul>
 Brackets	 Bar	<p><b>Provided on order</b></p> <ul style="list-style-type: none"><li>• Middle clamps + M8 bolt</li><li>• End clamps + M8 bolt</li></ul>
 Square washers	 Cover	<p><b>Tools required</b></p> <ul style="list-style-type: none"><li>• M8 allen key</li><li>• M8 spanner</li><li>• Electric screwdriver (riveter)</li></ul>
		 Cover for M8 nut

# INSTALLATION IN JUST 4 STEPS



POSITION THE SUPPORTS

ATTACH THE PANELS TO THE LANDBLOCK®

USE WATER FOR BALLAST

PUT THE COVER ON

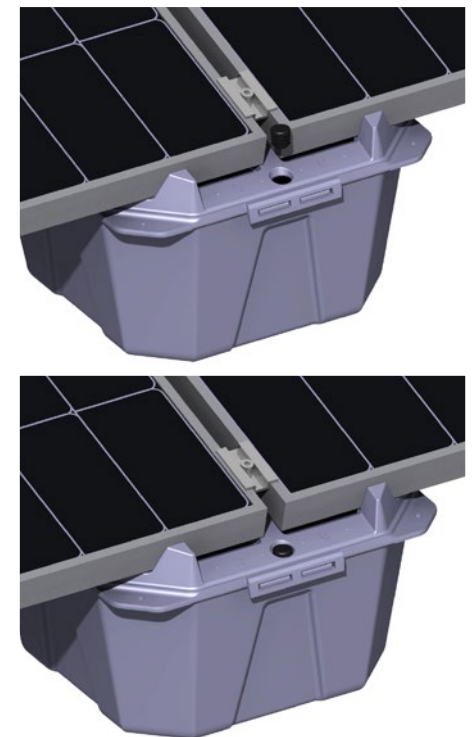
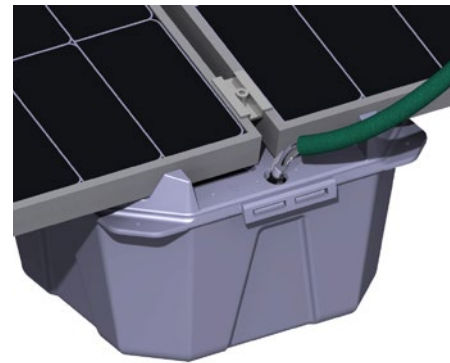
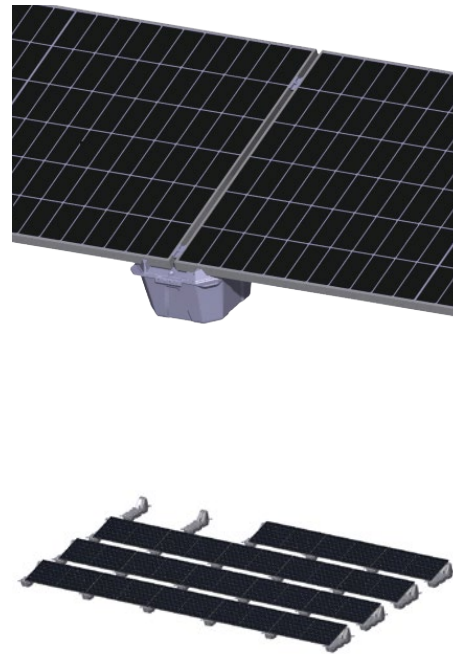
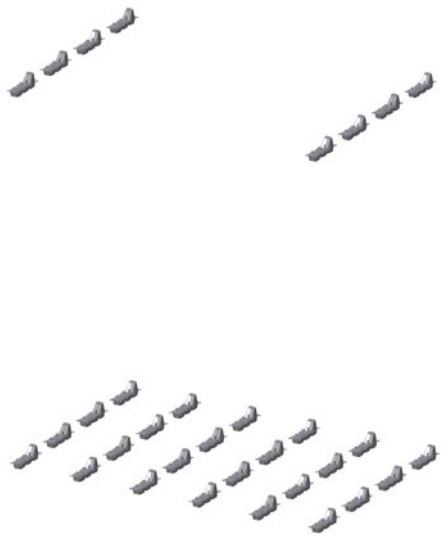



# 1

## LANDBLOCK® positioning

### Step 1 A

To assemble the LANDBLOCK® put a cover on each base and push the 'click' closure (without tools).

**Important:** Fit the cover on the base properly so it closes properly and the water doesn't evaporate.

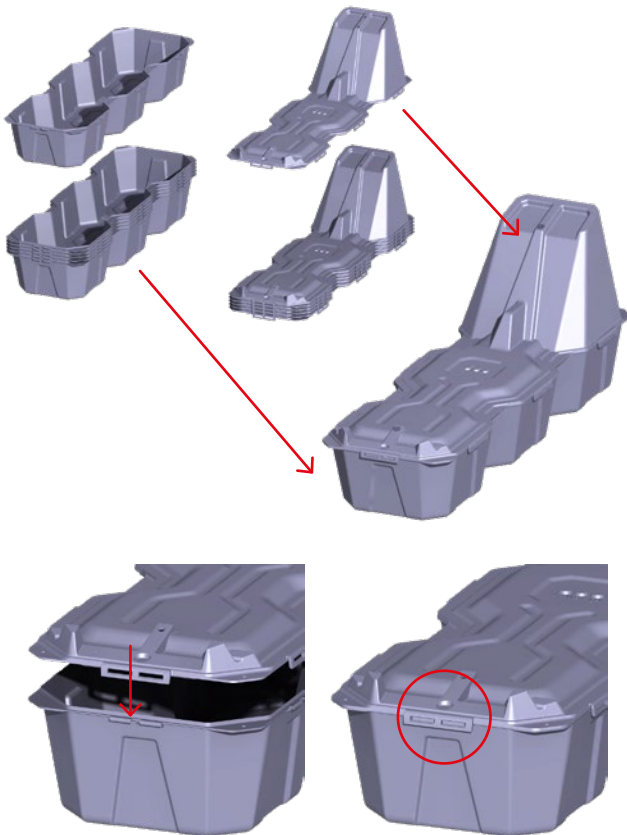

### Step 1 B

Lay out the LANDBLOCKS® in the required configuration depending on the size of the module you're using. You should pay attention to the distance between the panels (e.g. 2 cm).



**Recommendation:** Put the first and last LANDBLOCK® on every row in the area and run a line from the first lug to the last one to use as a guide for levelling and lining up the rest of the LANDBLOCK®.

LANDBLOCK®



### NEW

The anchor areas of the LANDBLOCK® have been reinforced to improve panel attachment.

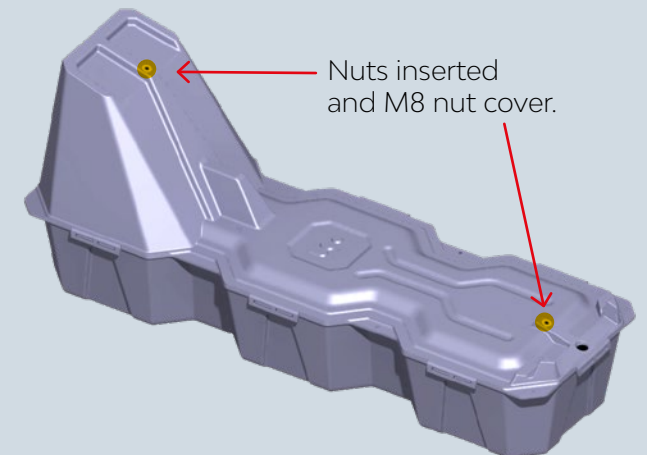
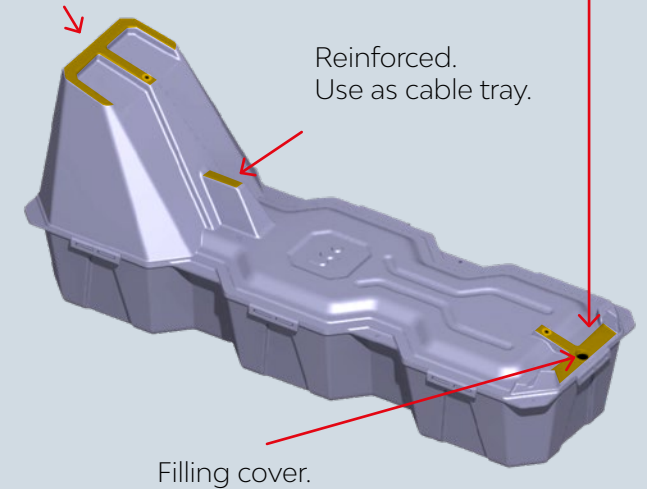

# 2

## Installing connectors and panels

### 2.1 Installation N+1

N+1 configuration with middle and End clampss



Valid configuration for all kinds of panels wider than 990 mm

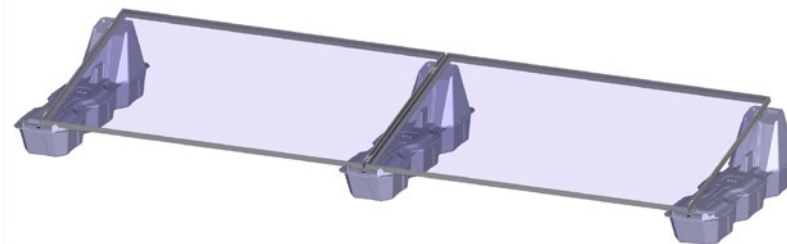

#### Step 2.1A

Put the washers with the middle clampss on the middle supports and the ones with End clampss on the end supports.

**Note:** See page 12 of the specifications annexe for the middle and End clampss.

#### Step 2.1B

Support the solar panel horizontally on the LANDBLOCK® supports.

**Recommendation:** First support the panel on the lower plane of the support.

**Important:** Make sure the panel is sitting on the square washers properly before tightening down the middle and End clampss.

#### Step 2.1C

Tighten down the middle and End clampss using M8 tools to attach the panel onto the support.

#### LANDBLOCK® Material

- ✓ LANDBLOCK® Base
- ✓ LANDBLOCK® Cover
- ✓ Cover 1 × LANDBLOCK®
- ✓ Square washers

#### Provided on order

- Middle clampss
- End clampss

#### Required profiles

End clampss:  
4 × number of rows

Middle clampss:  
(2 × no. panels - 2) × no. rows

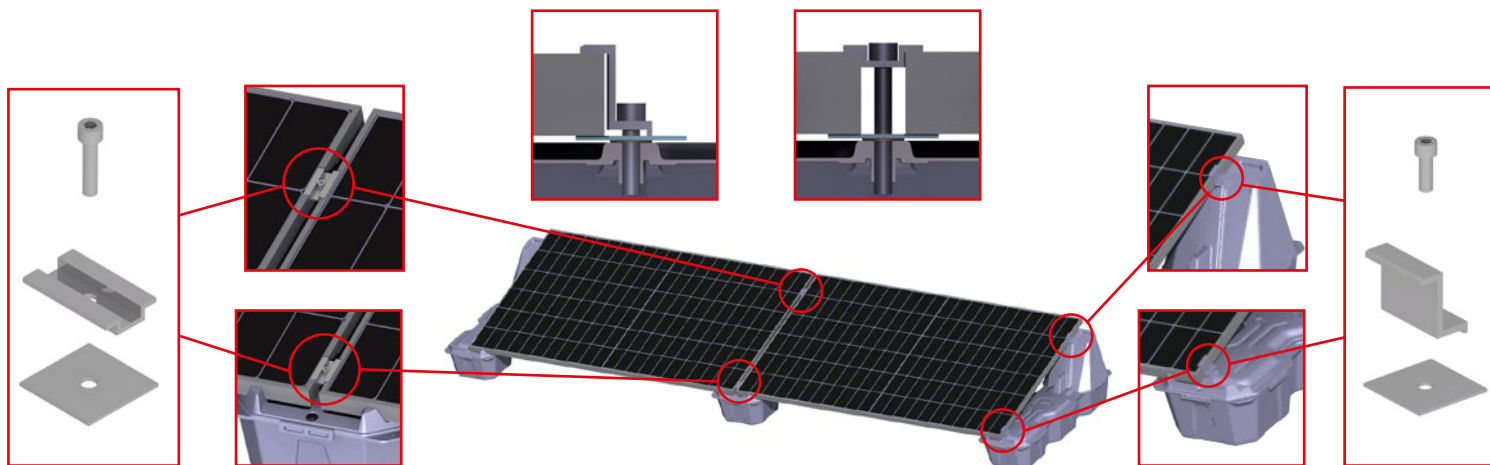

## 2.2 Installation 2N+1

### 2N+1 Configuration with middle and End clamps

#### Step 2.2A

Fit the bracket into the required anchor point. Avoid having the bracket be on top of the filling cover.

Use a rubber mallet to fit the bracket if necessary.

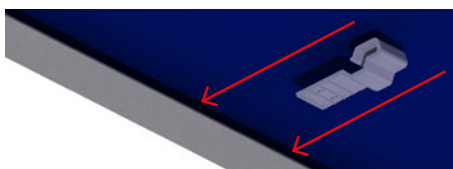

#### Step 2.2B

For the LANDBLOCK® CENTRAL: Screw the bar on the top with an M8 bolt. Use the small holes to attach the bar using pop rivets (or screws) depending on the width of the panel.

**Note:** See the position of the bar for different panel widths on page 9.

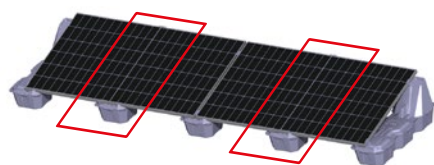

Put the End clamps on the elongated hole of the bar.

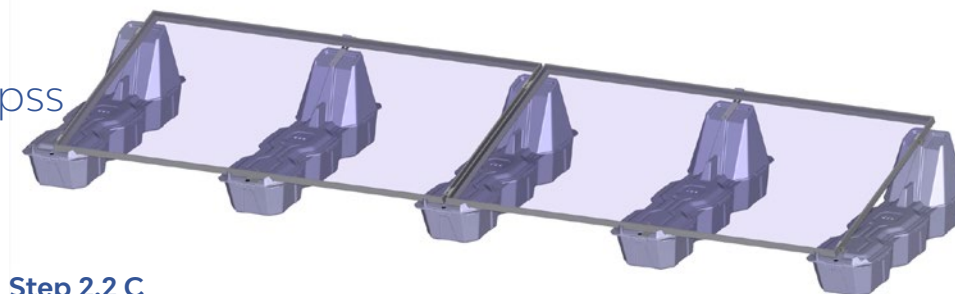
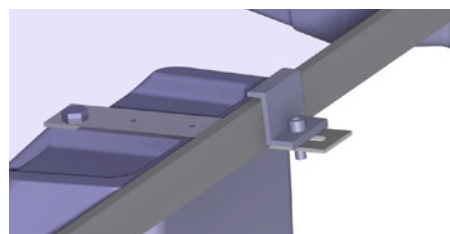

#### Step 2.2 C

Put an M8 cover in the hole for the front nut whenever a bracket is used.



Do steps 2.1A, 2.1B and 2.1C to install the middle and End clamps as shown in the previous step N+1.

Attach the front bracket (previously installed in 2.2A) to the bottom of the LANDBLOCK® using screws or pop rivets.

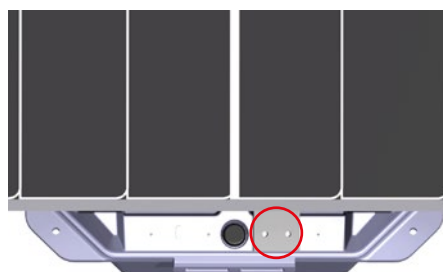

#### LANDBLOCK® Material

- ✓ LANDBLOCK® Base
- ✓ LANDBLOCK® Cover
- ✓ Cover for M8 nut  
1 × no. panels
- ✓ Bar 1 × no. panels
- ✓ Bracket 1 × no. panels
- ✓ Square washers  
Filling cover

#### Provided on order

- Middle clamps
- End clamps

#### Required profiles

End clamps:  
(4 × number of rows)  
+ (1 × number of panels)

Required middle clamps:  
(2 × no. panels - 2) × no. rows



# 2

## Installing connectors and panels

2N+1 configuration for panels between 1080 and 1140 mm wide

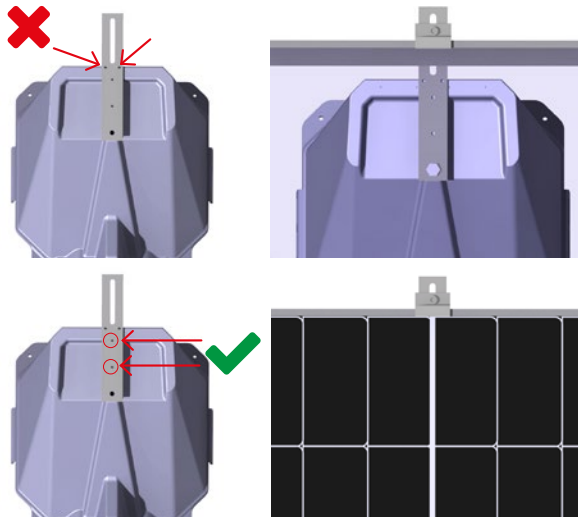

2N+1 configuration for panels between 1038 and 1052 mm wide

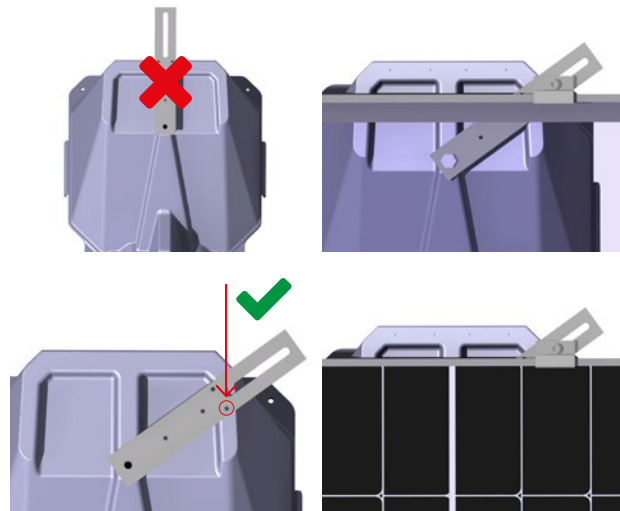

2N+1 configuration for panels between 992 and 1000 mm wide

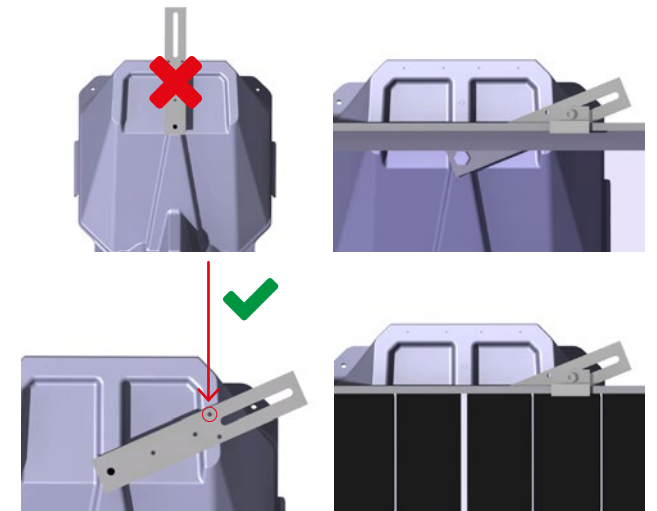

## 2.3 Installation 2N

### 2N Configuration with End clamps and brackets

#### Step 2.3A

Fit the bracket into the required anchor point. Avoid having the bracket be on top of the filling cover.



For two LANDBLOCK®:  
Screw the bar onto the top with an M8 bolt. Use the small holes (as shown on the previous page)\* to attach it using pop rivets (or screws) depending on the width of the panel.

**Note:** See the position of the bar for different panel widths on page 9.



#### Step 2.3B

Put the End clamps on the bar of the LANDBLOCK®.

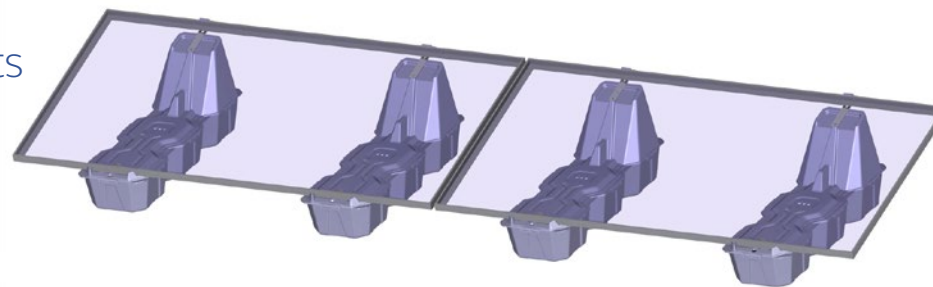
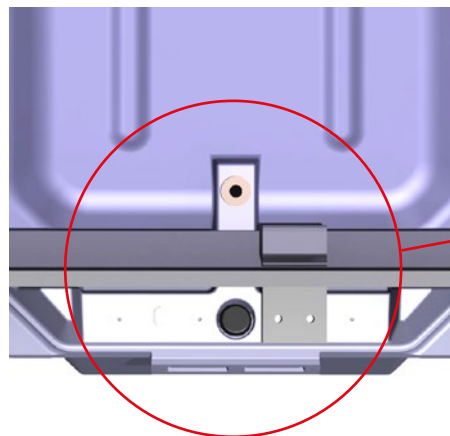
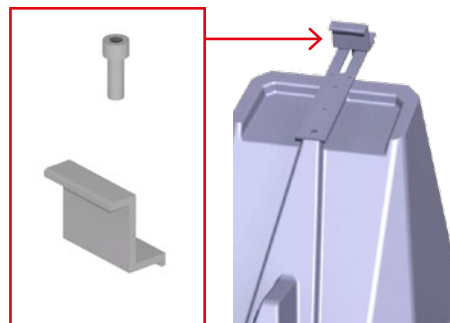

#### Step 2.3C

Put an M8 cover in the hole for the front nut whenever a bracket is used.

Support the panel on the LANDBLOCK® horizontally and attach the front bracket (previously installed in 2.3A) to the bottom of the LANDBLOCK® using screws or pop rivets.

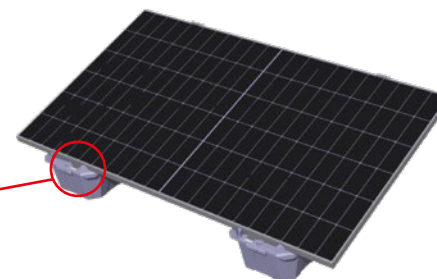

#### LANDBLOCK® material

- ✓ LANDBLOCK® Base
- ✓ LANDBLOCK® Cover
- ✓ Cover for M8 nut  
1 × no. panels
- ✓ Bar 1 × no. panels
- ✓ Bracket 1 × no. panels
- ✓ Filling cover

#### Provided on order

- End clamps

#### Required profiles

End clamps:  
2 × number of panels

# 3

## USE WATER FOR BALLAST

### Step 3

After completing **Step 2**, and with the LANDBLOCK® and the panels installed in the appropriate position, fill the support with water using the hole.

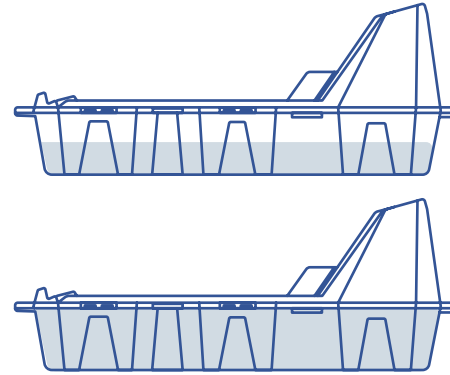
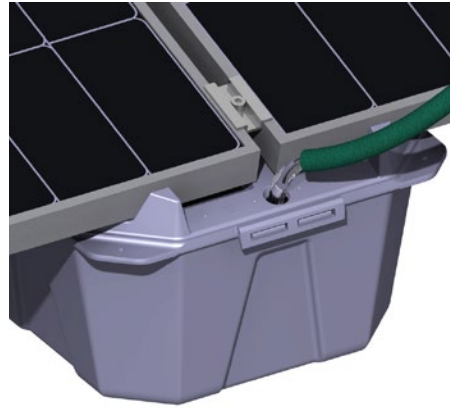

# 4

## Fit the cover

### Step 4

Close the hole with the cover after you've finished filling the LANDBLOCK®.



**Your system  
is ready!**

# ANNEXE

## Specifications for middle and Z connectors

### End clamps

For correct End clamps installation you must make sure that the photovoltaic module or modules support on the square washer at least **8 mm**.

That means that the Z bracket must not be more than **17 mm** from the bolt shaft and the vertical support plane of it.

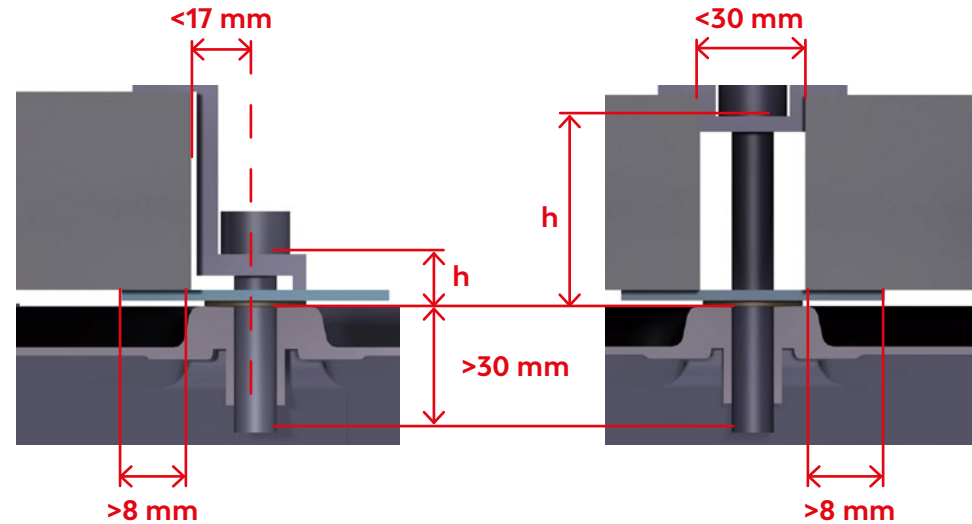

### Middle bracket

Likewise, to make sure the modules support a minimum of **8 mm** over the washers the distance between the support plane of the middle clamps and the panel should not exceed **30 mm**.

### Required bolt length

The length will depend on the thickness of the panel and the design of the connectors (Middle and End clamps). The installer will be responsible for checking and installing a bolt that is inserted and threaded into the M8 nuts of the support is at least **30 mm**. (panel support plane or square washer support plane)

Likewise, the required bolt length must be greater than the sum of the distance of the horizontal plane (**h**) + the **30 mm** length of the threads.

Length required = **>h+ 30mm**

**⚠** The installer is responsible for using connectors that meet those conditions. Landatu Solar can provide suppliers of connectors that meet the specifications on request.



## Factors to be taken into account depending on the type of rooftop, surface, wind load and evaporation

- ✓ LANDBLOCK® should only be used as a ballasted support for solar panel systems. Using the support for any other purpose is outside the scope of the intended use and is not allowed.
- ✓ The design of the system is the responsibility of the installer. You must make sure that the solar system meets the requirements set forth in the building code.
- ✓ It is important to be aware of the meteorological conditions of the country /region where the system is being installed to calculate the ballast and adjust the supports. Landatu Solar S.L. can provide a spreadsheet for calculating the ballast needed for a system on request.
- ✓ For greater safety in the most exposed areas, you could choose:
  - The **2N+1 configuration** described in the manual Combining both configurations in a single project may be interesting: a **2N+1 configuration** for areas around the edges and an **N+1 configuration** for inner areas.
  - Other materials can be used as ballast in the base, like gravel, sand, fine gravel or concrete (close the LANDBLOCK® before the concrete sets).
  - Guylines can be used. The lugs of the LANDBLOCK® can be anchored with metal cables to perimeter walls or other attachment points.
  - Using or choosing these additional safety measures is the responsibility of the installer or project planner.
  - Wind deflectors can be added on the sides and back to reduce wind loads. They can be ordered from Landatu Solar.
- ✓ To improve the friction coefficient you can:
  - Use an adhesive between the support and the ground.
- ✓ LANDBLOCK® has been tested to show the ballast water doesn't evaporate.



## Basic maintenance

LANDBLOCK® maintenance is simple and economical.

Suitable PPE (personal protective equipment) for the job you will be doing must be used.

Recommended at least once a year

- ✓ Check that the supports are in good condition and there are no water leaks
- ✓ Confirm that the weight of the ballast matches the weight it was designed for.
- ✓ Check the condition of the bolts and whether they are tightened correctly
- ✓ Check the rest of the parts of the structure, if there are any (non-slip mats, adhesives, guylines).

The entire photovoltaic system should be checked at least once a year (module cleanliness, connections, protective devices, etc.). If you need to open a LANDBLOCK® for any reason you should use pliers and pry from the centre of the closure..





**We optimise the use of surfaces  
to generate clean and sustainable  
energy**



**LANDATU**

S O L A R

[info@landatusolar.com](mailto:info@landatusolar.com)  
[www.landatusolar.com](http://www.landatusolar.com)