

BEDIENUNG UND INSTALLATION
OPERATION AND INSTALLATION
UTILISATION ET INSTALLATION
BEDIENING EN INSTALLATIE
USO E INSTALLAZIONE
OBSLUHA A INSTALACE
OBSŁUGA I INSTALACJA
KÄYTTÖ JA ASENNUS
OPERACIÓN E INSTALACIÓN

Internet Service Gateway

» ISG web

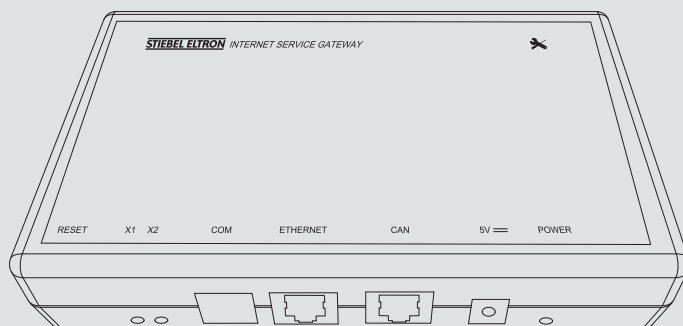

STIEBEL ELTRON

OPERATION

1. General information	15
1.1 Relevant documents	15
1.2 Safety instructions	15
1.3 Other symbols in this documentation	16
1.4 Units of measurement	16
2. Safety	16
2.1 Intended use	16
2.2 Appliance compatibility	16
2.3 General safety instructions	16
2.4 Data security	16
2.5 Instructions, standards and regulations	16
2.6 Test symbols	17
3. Appliance description	17
3.1 SERVICEWELT	17
3.2 SERVICEWELT portal	17
3.3 Standard delivery	17
3.4 System requirements	17
4. Operation	17
4.1 Accessing SERVICEWELT	17
4.2 Start page	18
5. Troubleshooting	19

INSTALLATION

6. Installation	19
6.1 Installation site	19
6.2 Wall mounting	19
6.3 Power supply	20
7. Commissioning	20
7.1 Checks before commissioning	20
7.2 Registering on the home network	21
7.3 Network configuration in the SERVICEWELT	21
7.4 Restoring factory settings	22
7.5 Enabling data access from the SERVICEWELT portal	23
8. Specification	24

GUARANTEE

ENVIRONMENT AND RECYCLING

OPERATION



1. General information

The chapter "Operation" is intended for appliance users and qualified contractors. The chapter "Installation" is intended for qualified contractors.



Note
Read these instructions carefully before using the appliance and retain them for future reference.
Pass on the instructions to a new user if required.

1.1 Relevant documents

-  Operating and installation instructions for the connected heat pump/integral ventilation unit
-  Operating and installation instructions for the heat pump manager (WPM)
-  Software documentation for the integral Modbus TCP/IP software interface

1.2 Safety instructions

1.2.1 Structure of safety instructions



KEYWORD Type of risk
Here, possible consequences are listed that may result from failure to observe the safety instructions.
► Steps to prevent the risk are listed.

1.2.2 Symbols, type of risk

Symbol	Type of risk
	Injury

1.2.3 Keywords



KEYWORD	Meaning
DANGER	Failure to observe this information will result in serious injury or death.
WARNING	Failure to observe this information may result in serious injury or death.
CAUTION	Failure to observe this information may result in non-serious or minor injury.

OPERATION

Safety

1.3 Other symbols in this documentation

 **Note**
General information is identified by the adjacent symbol.
▶ Read these texts carefully.

Symbol	Meaning
	Material losses (appliance damage, consequential losses and environmental pollution)
	Appliance disposal

▶ This symbol indicates that you have to do something. The action you need to take is described step by step.

1.4 Units of measurement

 **Note**
All measurements are given in mm unless stated otherwise.

2. Safety

2.1 Intended use

The Internet Service Gateway (ISG) is an information and communication interface between your heat pump/integral ventilation unit and your home network.

This appliance is intended for domestic use. It can be used safely by untrained persons. The appliance can also be used in a non-domestic environment, e.g. in a small business, as long as it is used in the same way.

Any other use beyond that described shall be deemed inappropriate. Observation of these instructions and of instructions for any accessories used is also part of the correct use of this appliance.

2.2 Appliance compatibility

 **Note**
Your system's date of manufacture must meet the minimum requirements. Otherwise, your system is not designed for operation with the ISG.
▶ Note the manufacturing date of your system.

 **Note**
The ISG is only compatible with systems whose heat pump manager (WPM) is equipped with the minimum software versions.
▶ If in doubt, consult our service department.

 **Note**
The Modbus TCP/IP software is installed on the ISG at the factory and can be used with compatible devices.

 **Note**
Any FEK remote control installed must have at least software version 9506 or higher.

 **Note**
Do not operate the ISG with a DCO active GSM on the same CAN BUS. This can impair communication with the WPM.

You can find an overview of compatible heat pumps / integral ventilation units on our website.

<https://www.stiebel-eltron.de/de/home/service/smart-home/kompatibilitaetslisten.html>

2.3 General safety instructions

 **WARNING Injury**
The appliance may be used by children aged 8 and up and persons with reduced physical, sensory or mental capabilities or a lack of experience and know-how, provided that they are supervised or they have been instructed on how to use the appliance safely and have understood the resulting risks. Children must never play with the appliance. Children must never clean the appliance or perform user maintenance unless they are supervised.

We guarantee trouble-free function and operational reliability only if original accessories and spare parts intended for the appliance are used.

2.4 Data security

 **Note**
Security of your home network is your responsibility.

 **Note**
The router in your home network represents a potential vulnerability to internet attacks.
It is therefore important to observe the following advice when configuring your router:

- Activate the internal firewall of the router.
- Change the default login details for the router's internal website.
- Use a secure WiFi password with WPA2 encoding (not WEP!).
- Disable any remote maintenance options for your router.
- Only enable required standard ports (e.g. port 80).
- Regularly update your router firmware.

To protect your personal and product-related data, we comply with the provisions of the German Federal Data Protection Act.

2.5 Instructions, standards and regulations

 **Note**
Observe all applicable national and regional regulations and instructions.

2.6 Test symbols

See type plate on the appliance.

3. Appliance description

The ISG is an information and communication interface between your heat pump/integral ventilation unit and your home network. To do this, the ISG provides the local SERVICEWELT website.

3.1 SERVICEWELT



Note

SERVICEWELT is a local website that requires no internet connection.

When you connect the ISG to your heat pump/integral ventilation unit and your home network, your system data is prepared for the SERVICEWELT.

You can retrieve your system data and make system settings in the SERVICEWELT.

3.2 SERVICEWELT portal

Once you allow the SERVICEWELT portal to access your data, you can add additional service packs, subject to service agreement.

- ▶ You need to connect your ISG to the STIEBEL ELTRON server to enable data access.

3.2.1 Function with data access enabled

Once data access from the SERVICEWELT portal is enabled, in the event of a change, your system data is transmitted every 1-5 minutes to the SERVICEWELT portal and saved on the STIEBEL ELTRON server.



Note

For more detailed information on appliance functions and service packages, visit our website.

3.3 Standard delivery

The following are delivered with the appliance:

- Power supply unit
- Wall mounting bracket
- CAN BUS cable (5.0 m long)
- Crossover cable RJ45 grey CAT5E (3.0 m long)

3.4 System requirements



Note

Display problems can occur with certain web browsers. We recommend using Mozilla Firefox.

Computer

- Javascript-enabled web browser (Mozilla Firefox 3.0 or higher, Internet Explorer 7.0 or higher, Safari 4.0 or higher).
- Network connection (standard Ethernet 10/100 Base-T)
- Broadband internet access via ADSL, UMTS or LTE with data flat rate

Router

- DHCP active
- Free Ethernet interface



Note

Disable the energy saving function of your router's Ethernet interface allocated to the ISG.

4. Operation

4.1 Accessing SERVICEWELT

Windows 7

The ISG is displayed in "Windows Explorer" under "Network".

- ▶ Double click on "Internet Service Gateway" to access SERVICEWELT.



Note

With other operating systems, you will need to access Servicewelt via the web browser.

Calling up the SERVICEWELT in your web browser

- ▶ Enter "http://servicewelt" or "192.168.0.126" or the IP address assigned during commissioning in your web browser address bar. Press Enter.

SERVICEWELT opens. Your data will be loaded.



Note

If the access lock is enabled (see chapter "Access lock"), a login screen will appear first.

4.2 Start page

On the SERVICEWELT start page you will see an overview of your system and can make changes to the most important settings directly.

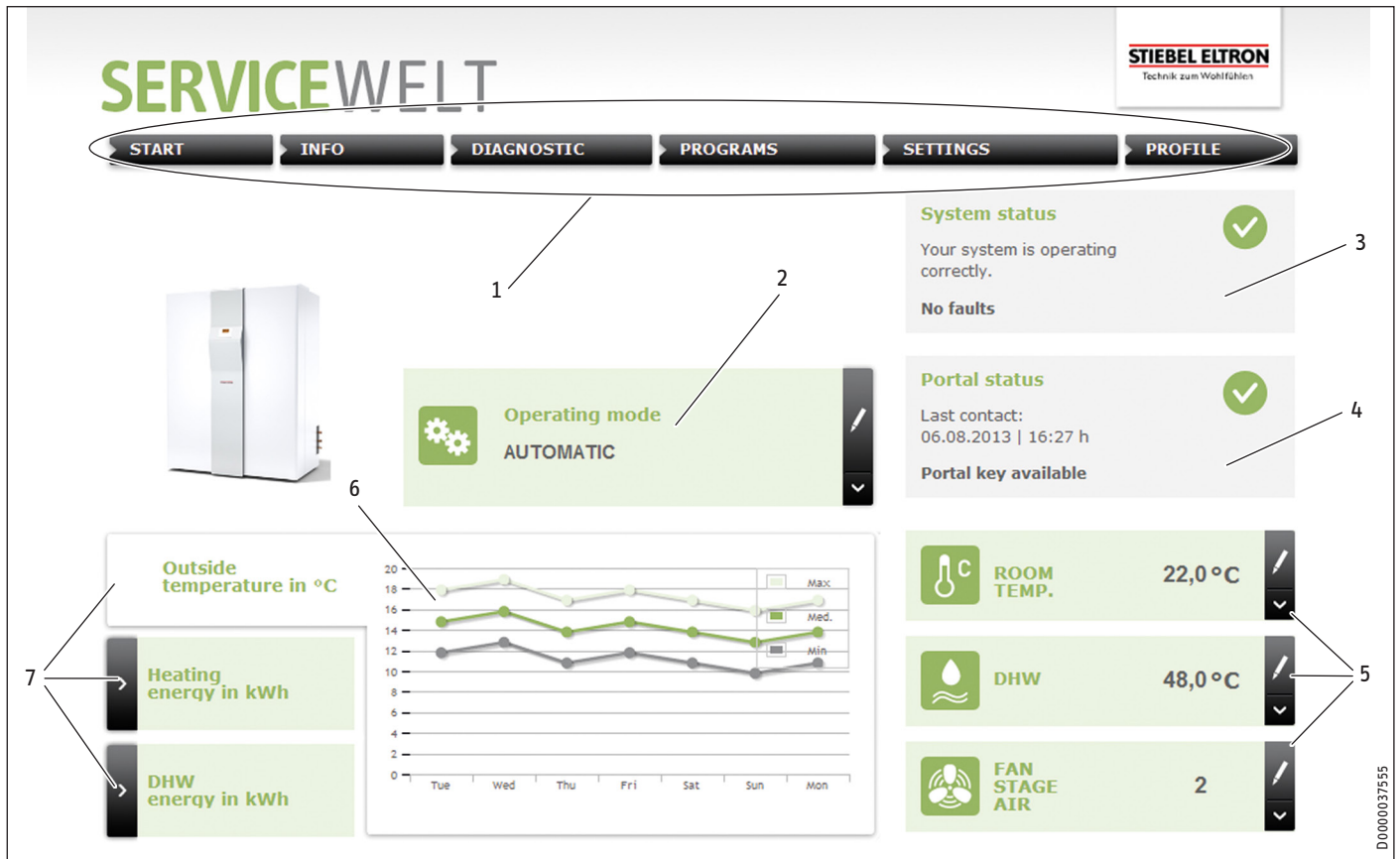

- 1 Menu
- 2 Operating mode
- 3 System status
- 4 Portal status
- 5 Quick access convenience values
- 6 Graph panel
- 7 Graph selection

4.2.2 Menu

The menu bar is always displayed at the top of the Servicewelt page. It is used to navigate the menu structure.

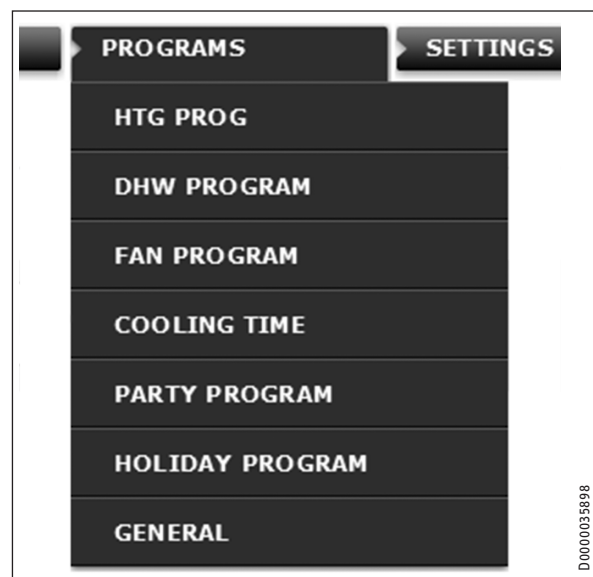

Moving the mouse pointer over one of the main menu items will open the corresponding submenu.

4.2.1 Symbols

Symbol	Meaning
	Edit Click here to change a set system value (e.g. temperature value).
	Select Click here to select a view (e.g. to switch between graphs on the start page).
	Cancel Click here to cancel the current action.
	Info Move the mouse pointer over the icon to display information about a menu item.
	Advanced settings Click here to view advanced settings options.

INSTALLATION

Troubleshooting

4.2.3 Operating mode

The set operating mode is displayed in the middle of the SERVICEWELT start page.

Changing the operating mode

- ▶ Click on "Edit".
- ▶ Select the required operating mode.
- ▶ Click on "Save".

The set operating mode is displayed.

4.2.4 System status

The "System status" field shows you information such as error messages.

4.2.5 Portal status

The portal status indicates whether the ISG is connected to the Stiebel Eltron server (see chapter "Enabling data access from the SERVICEWELT portal").

4.2.6 Quick access convenience values

You can set the following convenience values directly via the quick access menu:

- Internal room temperature (heating circuit 1)
- DHW temperature
- ▶ Click on "Edit" for the desired parameter.
- ▶ Set the desired value.
- ▶ Click on "Save".

The selection is made and displayed in the quick access menu.



Note

You can set convenience values for heating circuit 1 only via the quick access menu. You can adjust the full set of temperature settings under the "Settings" menu item.

4.2.7 Graph panel | graph selection

The graphs provide information about the system values of the last seven days.

You can select three different graphs for display:

- Outside temperature in °C
- Supplied heating energy in kWh
- Supplied DHW energy in kWh
- ▶ Click on "Select" in the desired graph.

The desired graph is displayed in the graph panel.



Note

The displayed graphs are based on calculated data and should not be used as reference values for billing purposes or similar.

5. Troubleshooting

If you cannot remedy the fault, consult our service department. To facilitate and speed up your enquiry, please provide the serial number from your heat pump/integral ventilation unit type plate (000000-0000-000000).



Note

In the event of problems with the on-site IT network, please consult an IT contractor.

INSTALLATION

6. Installation

6.1 Installation site

The ISG is designed for wall mounting and is installed between your router and your heat pump/integral ventilation unit.



Note

The ISG connects to the interface for the second programming unit.

- ▶ Observe the operating and installation instructions of your heat pump or integral ventilation unit.



Material losses

The installation site must be dry and protected against frost.

- ▶ Observe the application limits in the chapter "Specification".

6.2 Wall mounting

- ▶ Mount the ISG on a suitable wall:

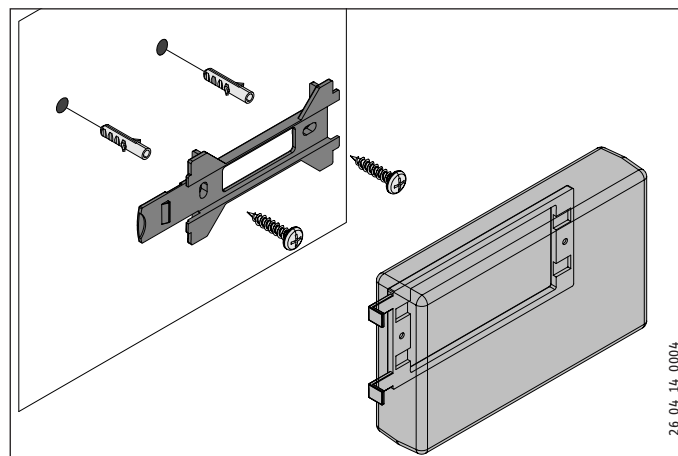

INSTALLATION

Commissioning

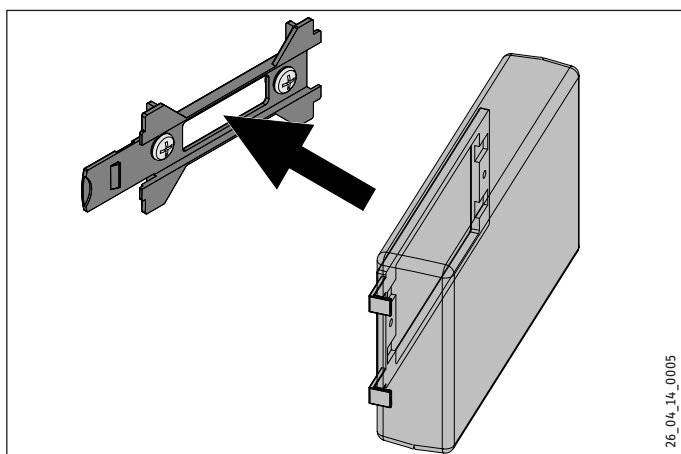

26_04_14_0005

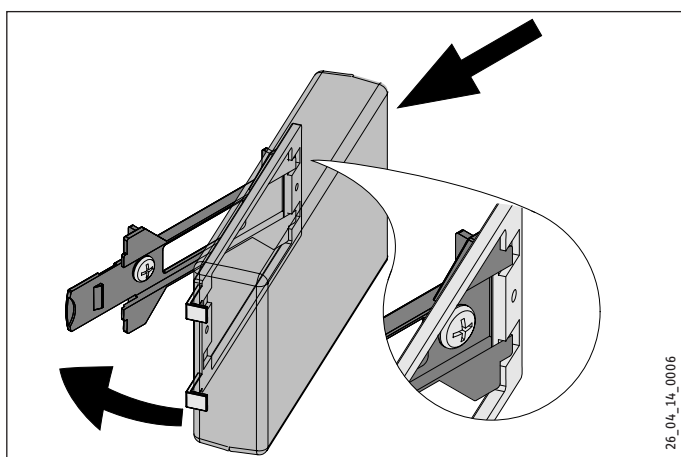

26_04_14_0006

- ▶ Push the ISG to the right, until you feel it latch into the retainer.

6.3 Power supply

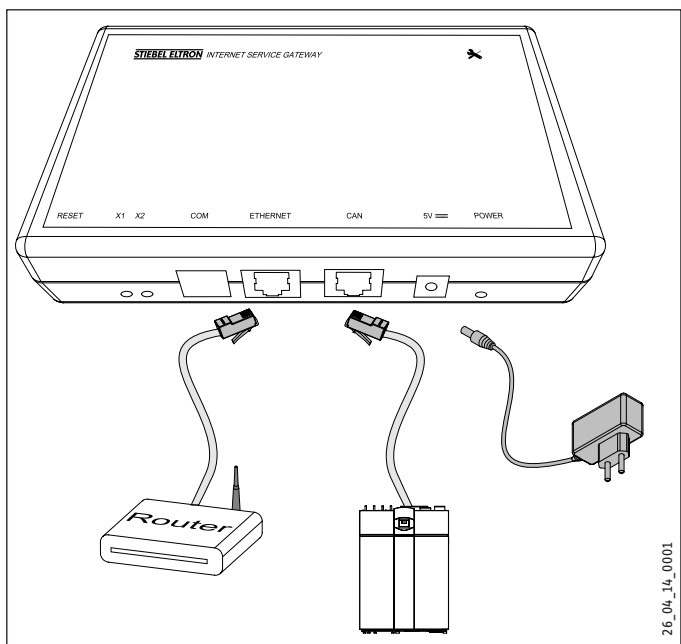

26_04_14_0001



Note

The ISG connects to the interface for the second programming unit or the remote control of your heat pump/integral ventilation unit.

If there is only one interface, the ISG connects in parallel to the CAN BUS as an additional programming unit.

- ▶ Use the CAN BUS cable supplied to connect the ISG to your heat pump/integral ventilation unit via the CAN interface. When doing so, observe the operating and installation instructions of your heat pump/integral ventilation unit.

CAN BUS cable connection:

- White: High
- Brown: Low
- Black: Earth (Ground)

- ▶ Use the crossover cable supplied to connect the ISG to your router.



Note

▶ Put the ISG into operation as the last bus subscriber.

▶ Before you connect the ISG to the power supply, make sure that the WPM has been commissioned and has fully started up.

- ▶ Connect the ISG to the mains using the power supply unit supplied.



Note

The COM interface is for service purposes only.

7. Commissioning

7.1 Checks before commissioning

Wiring

- ▶ Check the wiring between ISG, router, and heat pump/integral ventilation unit.

Power supply

When the power plug is plugged in, the ISG is switched on. The power LED is illuminated. The ISG requires about 30 seconds to start up.

- ▶ Check whether the power LED is illuminated.

Communication with the heat pump

LED X1 indicates the connection status to your heat pump/integral ventilation unit. LED X1 should be constantly flashing rapidly.

- ▶ Check the indication of LED X1.

LED X1	CAN connection status
constant rapid flashing	connection established
flashing	connection is being established
	no connection

INSTALLATION

Commissioning

Communication with the SERVICEWELT portal

LED X2 indicates the connection status to the SERVICEWELT portal (see chapter "Enabling data access from the SERVICEWELT portal"). When data access is not enabled, LED X2 illuminates red.

- ▶ Check the indication of LED X2.

LED X2	Portal status
illuminated red	no connection (connection is aborted after 3 attempts)
red rapid flashing	Contact the service department.
red / green flashing	Connection attempt
illuminated green	connection established
green flashing	Data transmission

Router settings

For automatic address assignment to the ISG, DHCP must be enabled on your router.

- ▶ Check your router settings.

7.2 Registering on the home network



Note

If required, refresh the website by pressing the F5 key or the web browser refresh button while registering with SERVICEWELT.

7.2.1 Registration via router

Automatic IP address assignment

If DHCP is enabled on your home network router, the ISG obtains its IP address automatically.

- ▶ Call up the SERVICEWELT (see chapter "Accessing SERVICEWELT").

If the Servicewelt does not open, the name resolution for "servicewelt" was unsuccessful.

- ▶ Change your web browser settings. Enter "servicewelt" as a proxy exception.
- ▶ Disable Google search.
- ▶ Carry out a manual registration.

Manual registration

- ▶ Enter "http://servicewelt" or "192.168.0.126" in the address bar of your web browser. Press Enter.

7.2.2 Registration without router

- ▶ Use the crossover cable supplied to connect the ISG to a network connection on your computer.
- ▶ Enter "http://servicewelt" or "192.168.0.126" in the address bar of your web browser. Press Enter.

If the Servicewelt does not open, you must manually assign your computer an IP address in the ISG standard IP address range.

Example:

The ISG has the default IP address "192.168.0.126". Your computer therefore obtains the IP address "192.168.0.100".

- ▶ Open the control panel and navigate to the "LAN connection" button (Windows 7).
- ▶ Click on "Properties".
- ▶ Click on "Internet protocol version 4".
- ▶ Check "Use the following IP address".
- ▶ In the field "IP address", enter "192.168.0.100".
- ▶ In the field "Subnet mask" enter "255.255.255.0".
- ▶ Click on "OK".
- ▶ Enter "http://servicewelt" or "192.168.0.126" in the address bar of your web browser. Press Enter.
- ▶ Restart your computer if the Servicewelt does not open.



Note

If the Servicewelt still does not open after manual IP address assignment and a restart, consult an IT contractor.



Note

Before disconnecting the ISG, reset the default network settings on your computer.

7.3 Network configuration in the SERVICEWELT



- ▶ Click on "Profile" in the menu bar to access the network settings.

INSTALLATION

Commissioning

MAC-address 02:80:AD:21:31:7B

SERVICEPORTAL via proxy server

DHCP

Proxy

D0000035903

DHCP is activated by default (factory setting). You must deactivate DHCP to enter an IP address manually.

- ▶ Uncheck DHCP to deactivate it.
- ▶ Enter your own IP address and the subnet mask.

DHCP

IP-address (DHCP) 192 168 0 126

Subnetmask (DHCP) 255 255 255 0

Gateway

Standardgateway 192 168 0 1

DNS-Server

DNS-Server 1 192 168 0 1

DNS-Server 2

DNS-Server 3

D0000062371

- ▶ Enter the DNS server name resolution.



Note

The default gateway and address of DNS server 1 are usually the router IP address.

- ▶ Enter "http://servicewelt" in the address bar of your web browser. Press Enter.

The Servicewelt or the selected IP address will open. Your data will be loaded.

Commissioning is now complete.



Note

We recommend bookmarking the SERVICEWELT or adding it to your favourites in your web browser.

7.3.1 Proxy server settings

The ISG supports the use of a proxy server (e.g. in corporate networks).

- ▶ To configure the proxy server, contact your network administrator.

Proxy

User name Proxyonly Please enter the username for the proxy-server.

Password Please enter the password for the proxy-server.

Repeat password Repeat the password here

Proxy-Server proxy.stiebel-eltron.com Please enter the proxy-server.

Portnumber 8080 Please enter the portnumber.

D0000064137



Note

When using a proxy server, we recommend setting up an access lock (see chapter "Access lock").

7.3.2 Access lock

You can set up an access lock to protect the SERVICEWELT available locally in your home network from unauthorised access.

- ▶ Click on "Profile" in the menu bar to access the security settings.
- ▶ Assign a username and password.
- ▶ Username and password are requested every time the SERVICEWELT is accessed locally.



Note

Username and password are freely selectable. They are not associated with other credentials you may have received for portal registration or mobile access.

7.4 Restoring factory settings

- ▶ To restore the ISG to factory settings, hold down the reset button using a fine pen or a paperclip for 10 seconds.

INSTALLATION

Commissioning

7.5 Enabling data access from the SERVICEWELT portal

To allow data transmission to the STIEBEL ELTRON server, you must enable the connection.

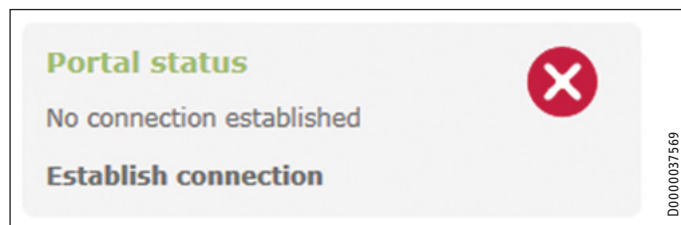

- ▶ Call up the SERVICEWELT.
- ▶ Click on "Establish connection" under "Portal status".



Note If there is no connection to the internet, a fault message is displayed.

An information window is displayed:

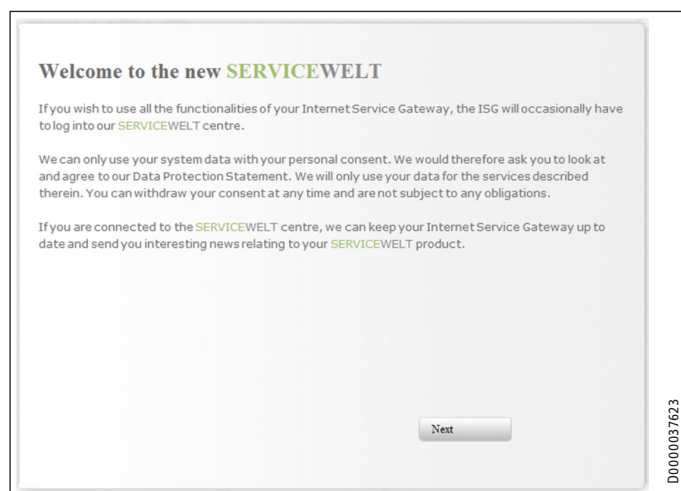

- ▶ Read the text in the information window.
- ▶ Click on "Next".

The data protection policy and terms of use are displayed.

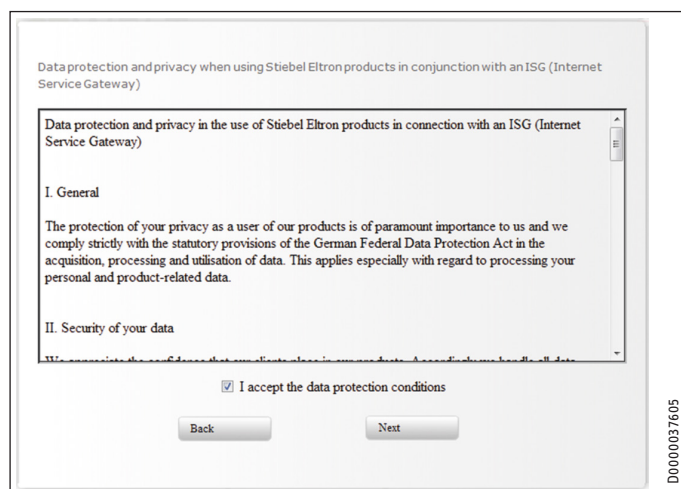

- ▶ Read the data protection policy.
- ▶ Agree by activating the checkbox below the data protection policy.
- ▶ Click on "Next".

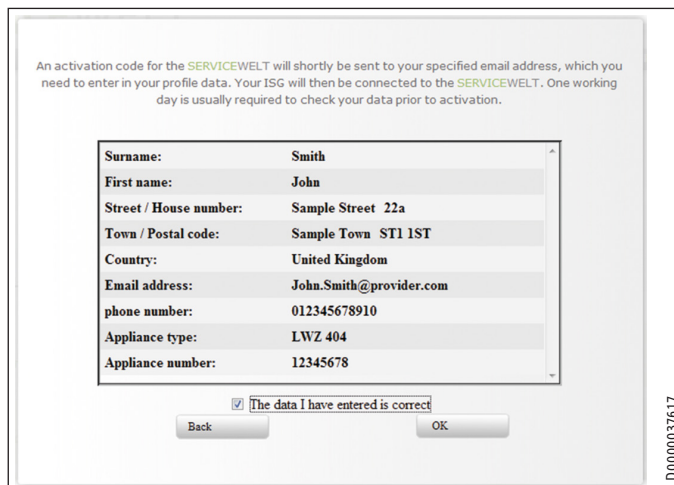

- ▶ Enter your personal data.



Note Enter your heat pump/integral ventilation unit data in the "Device type" and "Device number" fields.

- ▶ Click on "Next".

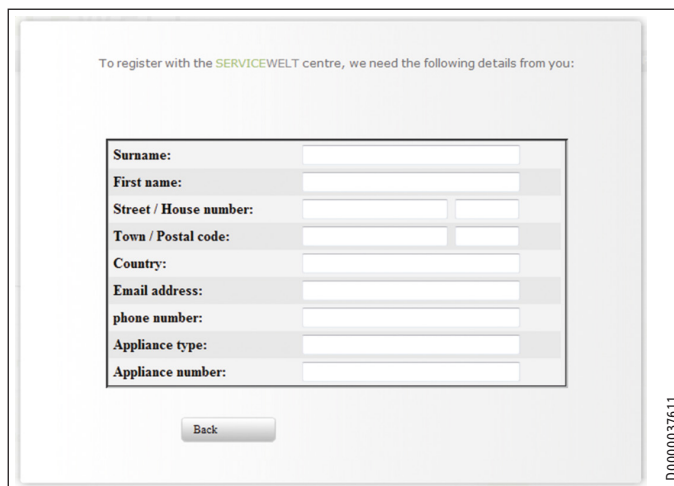

- ▶ Confirm your entry by activating the checkbox below the data protection policy.

On successful registration, you will receive a confirmation email within a few minutes.



- ▶ If you don't receive an email, check your spam folder.
- ▶ If you still don't receive an email, contact our service department.

- ▶ Read and follow the instructions in the email.

You will receive another email with the portal key.

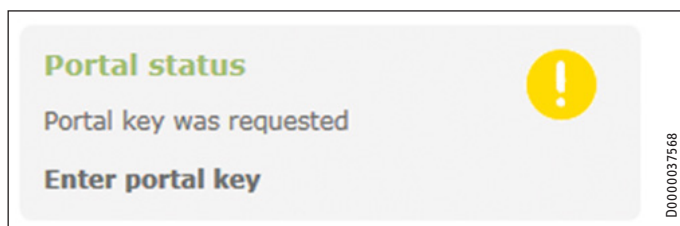

- ▶ Click on "Enter portal key".

An input window will open.

- ▶ Enter the portal key. Note upper and lower case and do not enter spaces.
- ▶ Click on "OK".

When the portal connection is successfully established, this is indicated under "Portal status".



Note

Once data access from the SERVICEWELT portal is enabled, you can set up mobile access.

- Contact our service department for the necessary credentials.
- You can access the mobile website at the following address: "https://servicewelt.stiebel-eltron.de/mobile/app/app.html"

8. Specification

		ISG web
		229336
Electrical data		
Max. power consumption	A	1.5
Dimensions		
Height	mm	95
Width	mm	158
Depth	mm	37
Connections		
CAN		RJ 45
RS232		RJ 12
10/100 Ethernet		RJ 45
Values		
Application range, min. / max.	°C	0...60

Guarantee

The guarantee conditions of our German companies do not apply to appliances acquired outside of Germany. In countries where our subsidiaries sell our products a guarantee can only be issued by those subsidiaries. Such guarantee is only granted if the subsidiary has issued its own terms of guarantee. No other guarantee will be granted.

We shall not provide any guarantee for appliances acquired in countries where we have no subsidiary to sell our products. This will not affect warranties issued by any importers.

Environment and recycling

We would ask you to help protect the environment. After use, dispose of the various materials in accordance with national regulations.