



Hybrid Inverter User Manual

INS-3.6LV-EUA1













CONTENTS





1. Safety Introduction	02
1.1 Explanation of Symbols	02
1.2 Safety Information	03
1.3 EU Declaration of Conformity	04
2. Product Introduction	05
2.1 Product Overview	05
2.2 Operating Modes	08
2.3 System Diagram	10
2.3.1 Retrofit System	11
2.3.2 Unacceptable Set-up Diagram	11
3. Installation Instruction	12
3.1 Packing List	12
3.2 Installation Tools	12
3.3 Mounting	13
3.3.1 Selecting the Mounting Location	13
3.3.2 Mounting Inverter	14
3.4 Electrical Wiring Connection	14
3.4.1 Grounding Connection	14
3.4.2 AC Wiring Connection	15
3.4.2.1 Grid Connection	15
3.4.2.2 GEN Connection	16
3.4.2.3 EPS Connection	16
3.4.3 PV Wiring Connection	18
3.4.4 Battery Wiring Connection	19
3.4.5 Communication Wiring Connection	20
3.4.5.1 BMS Connection	21
3.4.5.2 Smart Meter and CT Connection	22
3.4.6 DTS Connection	23
3.5 Operation	24
3.5.1 Commissioning	24
3.5.2 Decommissioning	24
4. Troubleshooting	25
5. Technical Datasheet	28

1. Safety Introduction

1.1 Explanation of Symbols

The following types of safety precautions and general information symbols used in this manual must be followed during the installation, operation and maintenance of the inverter.

Symbol	Usage
 DANGER	Indicates a hazard with a high level of risk that, if not avoided, will result in death or serious injury.
 WARNING	Indicates a hazard with a medium level of risk that, if not avoided, can result in death or serious injury.
 CAUTION	Indicates a hazard with a low level of risk that, if not avoided, can result in minor or moderate injury.
 NOTICE	Indicates a situation that, if not avoided, can result in property damage. NOTICE is used to address practices not related to personal injury.
	Caution! Failure to observe any warnings contained in this manual may result in injury.
	Danger to life due to high voltages! Only qualified personnel can open and maintain the inverter.
	Burn danger due to hot surface that may exceed 60°C.
	Refer to the operating instructions.
 10min	After the inverter is turned off, wait for at least 10 minutes before opening the inverter or touching live parts.
	Products shall not be disposed as household waste.
	CE mark.
	UKCA mark.



	<p>This side up! This package must always be transported, handled and stored in such a way that the arrows always point upwards.</p>
	<p>Fragile - The package/product should be handled carefully and should never be tipped over or slung.</p>
	<p>Keep dry! The package/product must be protected from excessive humidity and must be stored under cover.</p>
	<p>No more than six (6) identical packages are to be stacked on each other.</p>



1.2 Safety Information

This chapter contains important safety and operating instructions. For future reference, please read and keep this manual.

For the purpose of preventing personal injury and property damage, as well as ensuring the long-term operation of the product, please read and follow all the instructions and cautions on the inverter and in this user manual during installation, operation and maintenance.

Safety instructions in this manual cannot cover all precautions that should be taken. Please consider the actual conditions on site when performing operations. Any damage caused by a violation of the safety instructions in this manual shall not be the responsibility of InstaGroup.

Symbol	Usage
	<p>Danger to life from electric shock</p> <ul style="list-style-type: none"> • Before performing any work on the inverter, disconnect all DC and AC power from inverter and wait for at least 10 minutes. Hazardous voltage will exist for up to 10 minutes after disconnection from power supply. • Never insert or remove the AC or DC connections when the inverter is running. • Any live parts connected to battery ports cannot be touched before removing all the power from inverter for 10 minutes because there is still danger to life even battery voltage is lower than 60 V. • Do not touch DC conductors or any non-isolated cable ends. • The mounting location must be inaccessible to children. • Never touch either the positive or negative pole of PV connecting device. Strictly prohibit touching both at the same time.
	<p>Risk of burns from hot surfaces</p> <ul style="list-style-type: none"> • The surface of the inverter might exceed 60°C , and touching the surface may result in burns. • Do not touch hot surfaces before it cools down.

 <p>WARNING</p>	<ul style="list-style-type: none"> • Only trained professionals are allowed to install the inverter or perform servicing and maintenance. • All powers, both AC and DC, should be disconnected from inverter before attempting any maintenance, cleaning or working on any circuits connected to inverter. • Attempting to service the inverter yourself may result in a risk of electric shock or fire and will void your warranty. • Keep away from flammable and explosive materials to avoid fire disaster. • The installation place should be away from humid or corrosive substances. • The unit contains capacitors that remain charged to a potentially lethal voltage after the mains, battery and PV supply have been disconnected. • When accessing the internal circuit of inverter, wait for at least 10 minutes after disconnecting the power.
 <p>CAUTION</p>	<ul style="list-style-type: none"> • The inverter has a transformerless design on PV side. Neither positive nor negative terminals of PV panels should be grounded. • The frames of PV panels should be grounded for safety reasons. • Ensure that existing wiring is in good condition and no wire is undersized. • Do not disassemble any parts of inverter which are not mentioned in installation. • Authorized service personnel must use insulated tools when installing or working with this equipment. • PV modules shall have an IEC 61730 class A rating.
 <p>NOTICE</p>	<ul style="list-style-type: none"> • The minimum rated temperature of the wire used is 90°C (194°F). • All electrical connections must be in accordance with local and national standards. • Only with permission of the local utility grid company, the inverter can be connected to the utility grid. • Do not open the inverter cover or change any components without authorization, otherwise the warranty commitment for the inverter will be invalid. • Appropriate methods must be adopted to protect inverter from electrostatic discharge; any damage caused by ESD is not warranted by the manufacturer. • Prior to the application, please read this section carefully to ensure the correct and safe application. Please store the user manual in a safe and accessible location. • The manual contains no instructions for user-serviceable parts. See Warranty for instructions on obtaining service. • If an error occurs, contact your local distributor or qualified electricians.

1.3 EU Declaration of Conformity

InstaGroup Limited hereby declares that the inverter described in this document is in compliance with the basic requirements and other relevant provisions of the following directives.

- Electromagnetic Compatibility Directive 2014/30/EU (EMC)
- Low Voltage Directive 2014/35/EU (LVD)
- Restriction of the use of certain hazardous substances Directive 2011/65/EU and its amendment directives (EU) 2015/863 (RoHS)
- Waste Electrical and Electronic Equipment Directive 2012/19/EU (WEEE)

2. Product Introduction

2.1 Product Overview

The INS-3.6LV-EUA1 is a high-performance single-phase hybrid inverter with excellent reliability. The intelligent EMS function supports self-consumption, economic, and backup modes for multi-scenario applications. Monitoring management through Insta Cloud allows users to remotely diagnose and track the system performance over time, offering superior energy production.

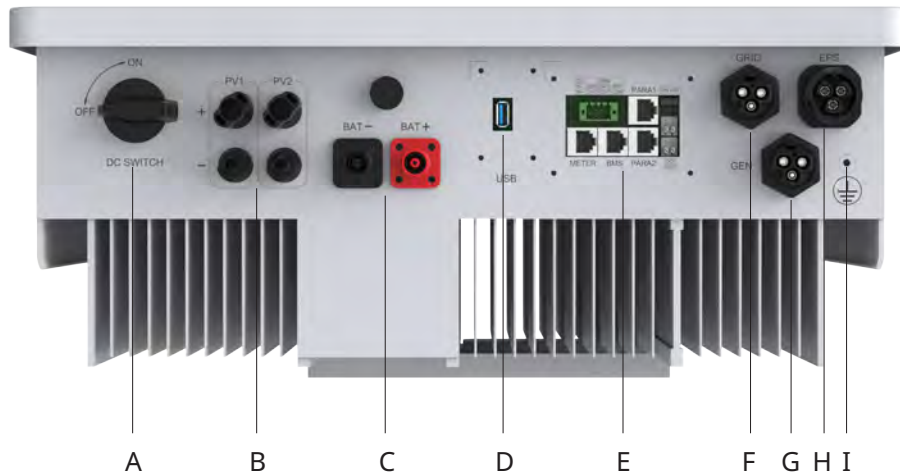

* The image shown here is for reference only. The actual product received may differ.

Object	Description
A	DC Switch
B	PV Terminals
C	Battery Terminals
D	Data Transfer Stick (DTS) Port
E	Communication Port
F	GRID Connector
G	Generator (GEN) Connector
H	Emergency Power Supply (EPS) Connector
I	PE Terminal

LED Indicators

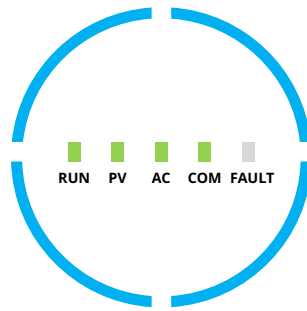

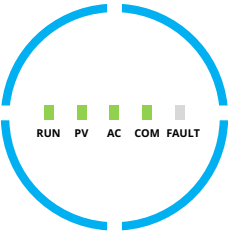
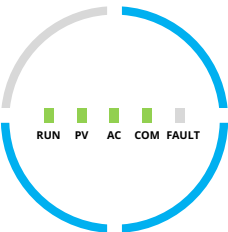
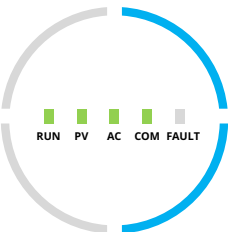
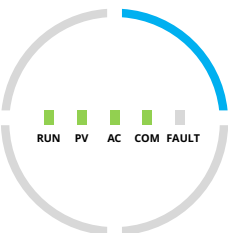
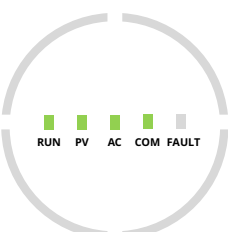
Indicator	Status	Explanation
SOC		Full circle LEDs on – SOC is 75-100%; battery is discharging or in standby Full circle LEDs blink – SOC is 75-100%; battery is charging
		3/4 circle LEDs on – SOC is 50-75%; battery is discharging or in standby 3/4 circle LEDs blink – SOC is 50-75%; battery is charging
		2/4 circle LEDs on – SOC is 25-50%; battery is discharging or in standby 2/4 circle LEDs blink – SOC is 25-50%; battery is charging
		1/4 circle LED on – SOC is 0-25%; battery is discharging or in standby 1/4 circle LED blinks – SOC is 0-25%; battery is charging
		Full circle LEDs off – No BMS communication

LED Indicators

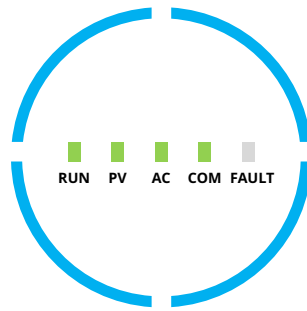

Indicator	Status	Explanation
RUN		Off - Inverter is shut down Blink 1 - Inverter is booting Blink 2 - Inverter is in bypass mode On - Inverter is turned on
PV		Off - PV voltage is low Blink 1 - PV power is low On - PV is generating power
AC		Off - Grid is disconnected and EPS is off Blink 1 - Grid is disconnected but EPS is on On - Grid is connected
COM		Off - Communication error of both meter and BMS Blink 1 - Communication failed to meter Blink 2 - Communication failed to BMS On - Both meter and BMS communications are normal
FAULT		Off - No fault On - A fault occurs Blink 1 - EPS port overload Blink 2 - ISO/RCD fault Blink 3 - Arc fault

2.2 Operating Modes

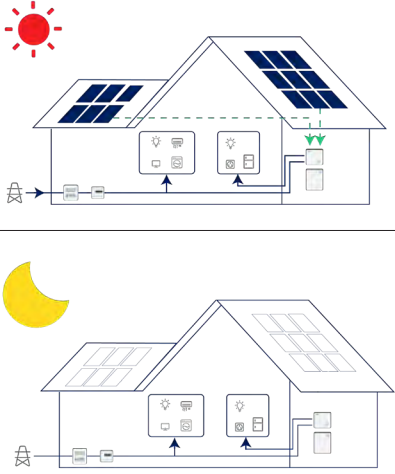
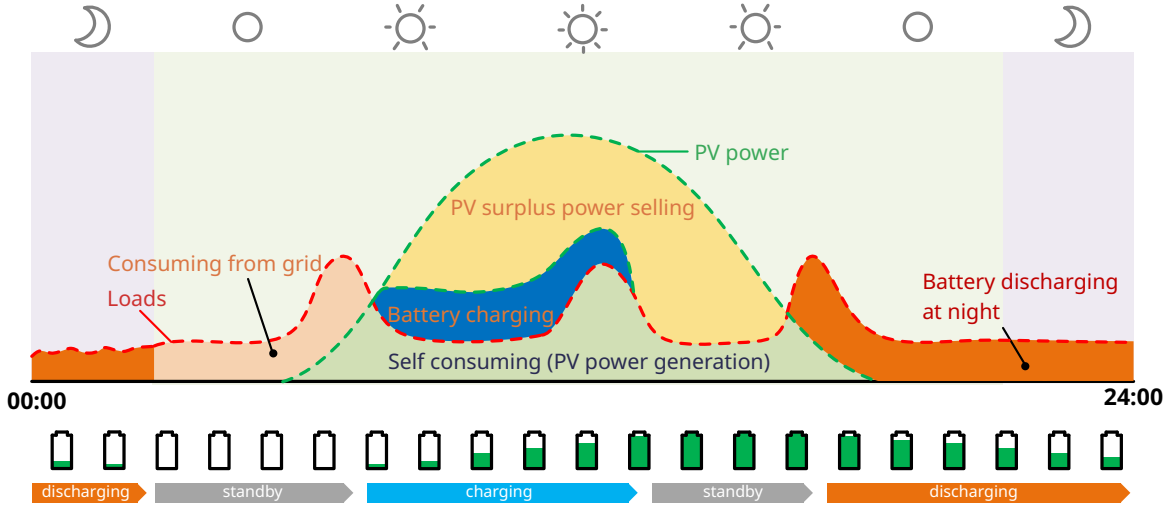
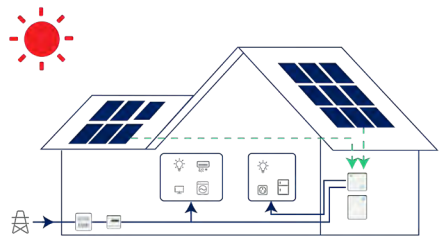
Main Operation Modes		
<p>Self-consumption Mode</p>	<p>In the daytime, solar energy supports the loads first and surplus energy is stored in the battery. When the battery is fully charged or reaches the maximum charge power, the rest of the energy is fed into grid (or limited if required).</p> <p>At night, the battery discharges for the loads first and the grid will supply the loads once the battery power is not enough. In this mode, battery cannot be charged from grid at night.</p>	
		
Power flow of self-consumption mode		
<p>Economic Mode</p>	<p>In this mode, the time of battery charge and discharge needs to be set. Meanwhile, the battery can be forced to charge from the grid during the preset charge time. For instance, the battery could be charged or discharged according to valley or peak electricity price.</p>	

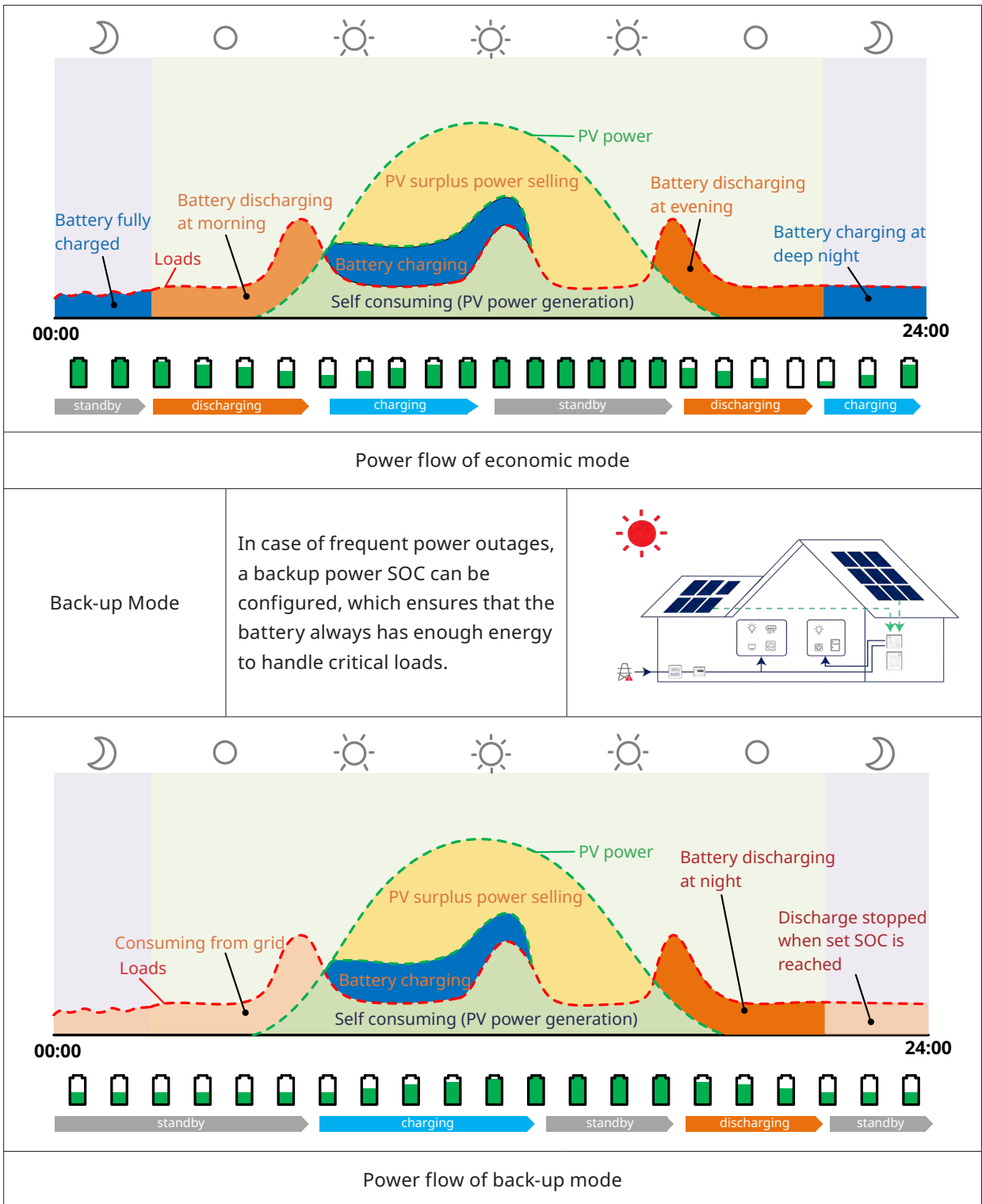

2.3 System Diagram

The INS-3.6LV-EUA1 inverter can be connected to a battery and PV panels to form a PV Energy Storage System (ESS). In the event of a grid outage, it can be used as an emergency power supply (EPS) through the self-consumption of solar energy. It can form a DC-coupled system for a new installation or an AC-coupled system to retrofit existing installations.

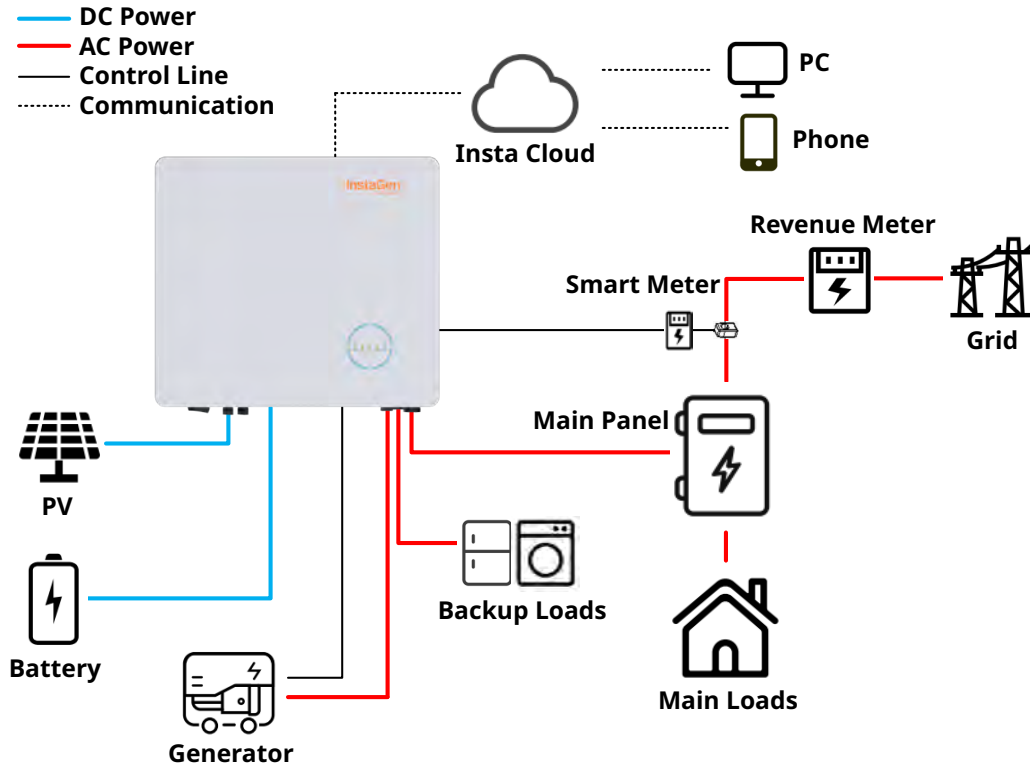

NOTICE

- This diagram is a simplified system sketch that is only intended to explain system architecture.
- This inverter is compatible with the InstaGen LV Battery.

2.3.1 Retrofit System

The INS-3.6LV-EUA1 inverter is compatible with any single-phase grid-connected PV inverters. With the addition of InstaGen hybrid inverter, existing PV system can be retrofitted to be a PV Energy Storage System (ESS) allowing more self-consumption energy and more back-up energy. Consult with your system integrator for detailed wirings according to your requirements.

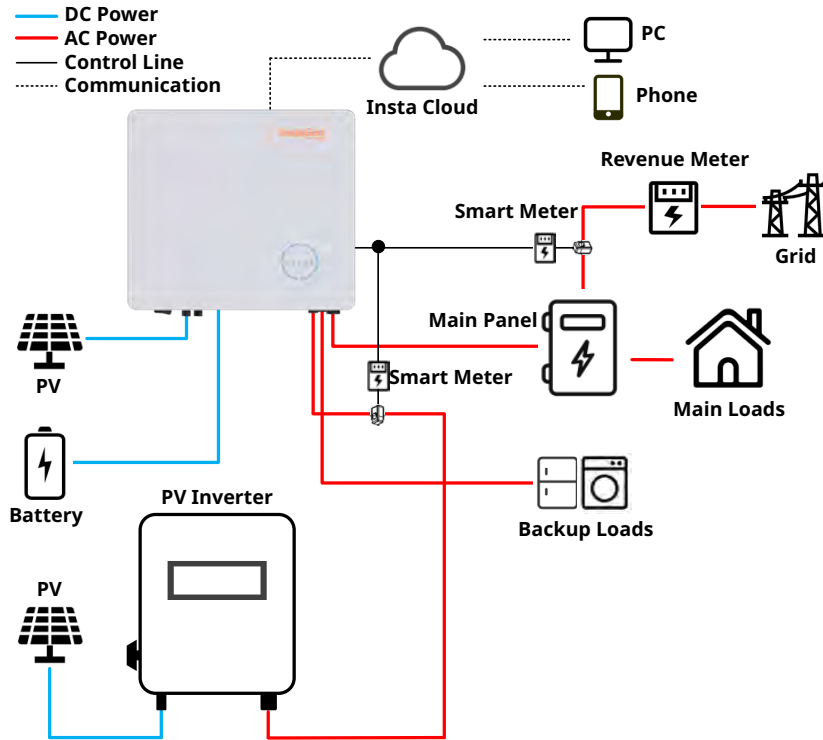

2.3.2 Unacceptable Set-up Diagram

Avoid the following installation types to prevent damage to the system or the INS-3.6LV-EUA1 inverter.

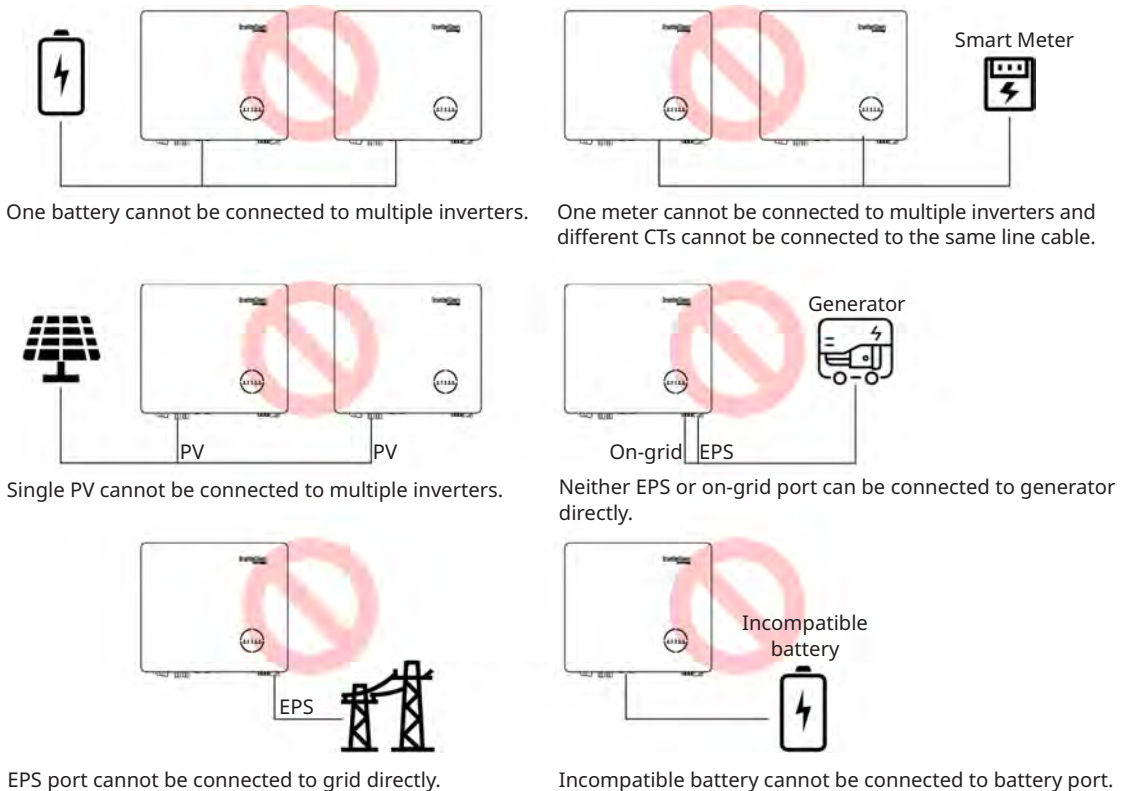

3. Installation Instruction

3.1 Packing List

Please ensure that none of the components listed below are missing or damaged upon receipt of the hybrid inverter. Please refer to the manual handling guidelines and regulations to remove the inverter from the packaging due to its heavy weight. For the Manual Handling Operations Regulations 1992, see <https://www.legislation.gov.uk/ukxi/1992/2793/contents/made>.

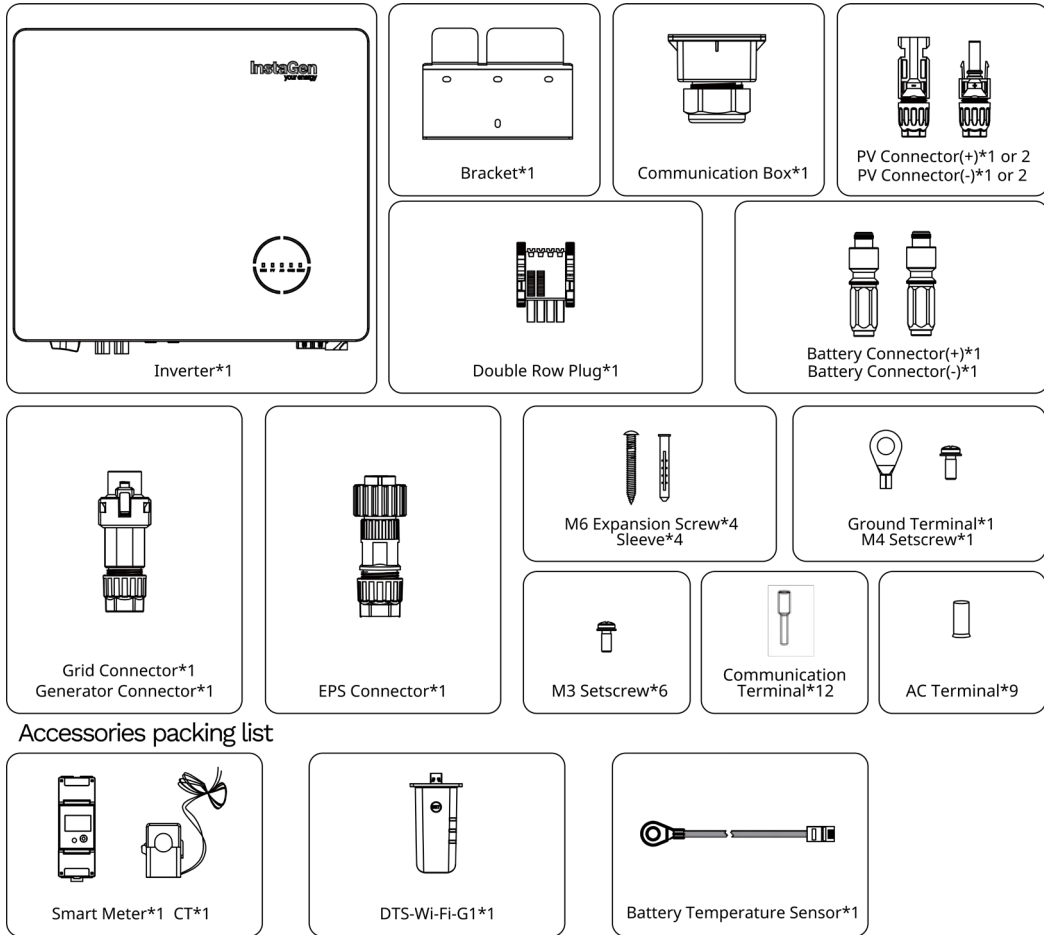

Accessories packing list

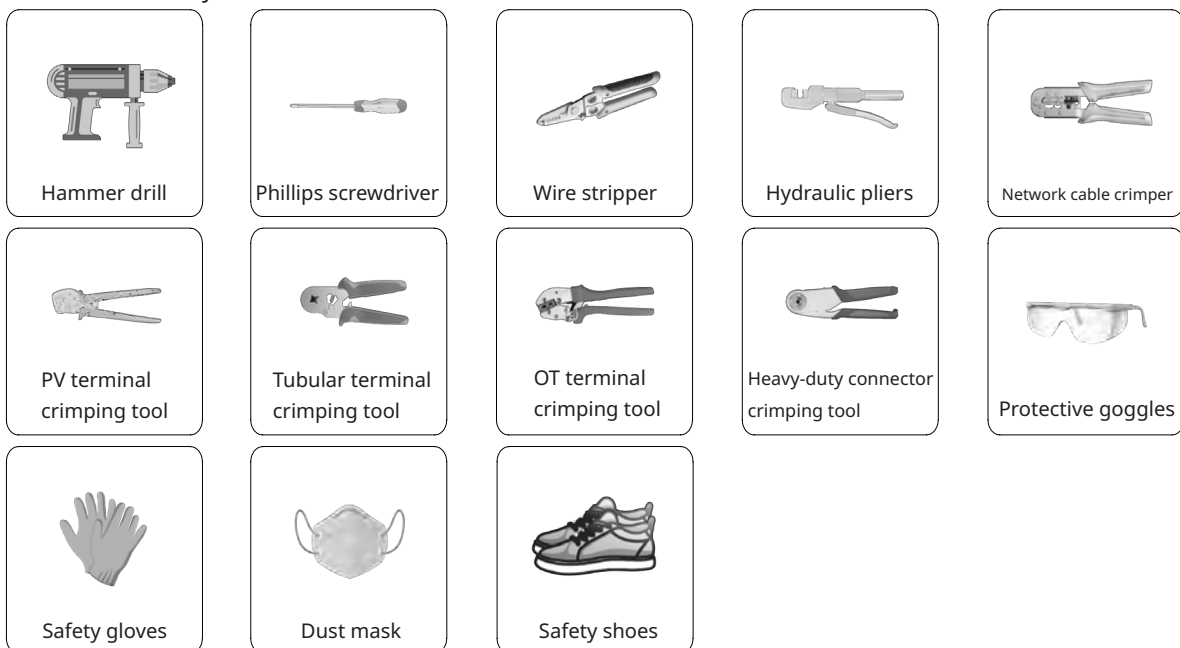

3.2 Installation Tools

The following tools are recommended in the installation process, and other auxiliary tools can also be used on site if necessary.



3.3 Mounting

3.3.1 Selecting the Mounting Location

 <p>WARNING</p>	<ul style="list-style-type: none"> • Make sure there is no electrical connection before installation. • In order to avoid electric shock or other injuries, make sure that holes are not drilled over any electrical parts or plumbing installations.
 <p>NOTICE</p>	<ul style="list-style-type: none"> • Make sure the inverter is correctly installed according to the following list. Any incorrect installation would require a risk assessment.

Check List

1. The inverter installation should be protected by shelter from direct sunlight or bad weather such as snow, rain or lightning.
2. The inverter should be installed on a solid surface which is suitable for the inverter's dimensions and weight.
3. The inverter should be installed vertically or at a maximum back tilt of 15°. Leave enough space around the inverter according to the figure below.



4. The inverter should be installed in an environment with good ventilation and heat dissipation conditions.
5. The ambient temperature should be between -25°C and 45°C. High ambient temperatures will cause power derating of the inverter.
6. The relative humidity should be less than 95%, without condensing.
7. The inverter should be installed at eye level for convenient maintenance.
8. The product label on the inverter should be clearly visible after installation.
9. The inverter should be installed far from flammable materials.

3.3.2 Mounting Inverter

Install the inverter on the wall using the provided wall-mounting bracket and expansion plug sets.

Procedure	
Step 1	Position the bracket against the wall and mark the 4 drilling hole locations.
Step 2	Drill holes and make sure the holes are deep enough (at least 60 mm).
Step 3	Place sleeves in the holes, and then tighten them.
Step 4	Fix the wall bracket with expansion screws. Please confirm that the bracket is firmly attached to the mounting surface.
Step 5	Mount the inverter on the bracket.

3.4 Electrical Wiring Connection

 WARNING	<ul style="list-style-type: none"> Prior to any electrical connections, keep in mind that the inverter has dual power supplies. It is mandatory for the qualified personnel to wear personal protective equipment (PPE) during the electrical work.
---	--

3.4.1 Grounding Connection

All non-current carrying metal parts and device enclosures in the PV power system should be grounded. There is an additional grounding terminal located at bottom right of the inverter, being connected to a nearby grounding point.

Procedure	
Step 1	Prepare the cable and OT/DT terminal.
Step 2	Use the screw from the accessory box. Then fasten the cable with a screwdriver.

3.4.2 AC Wiring Connection

3.4.2.1 Grid Connection

 <p>WARNING</p>	<p>Before connecting the grid, please make sure all requirements listed below are followed.</p> <ul style="list-style-type: none"> • Use the grid connector from the accessory box. Damage to the device due to the use of incompatible connector shall not be covered by the warranty. • An independent three or four-pole circuit breaker must be installed on the output side of the inverter to ensure safe disconnection from the grid. • Multiple inverters cannot share one circuit breaker. • Never connect a load between the inverter and the circuit breaker.
--	--

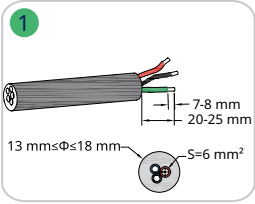
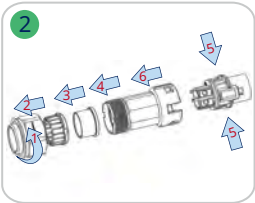
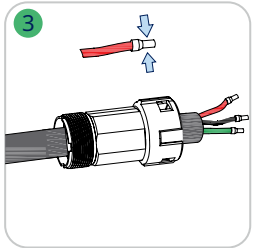
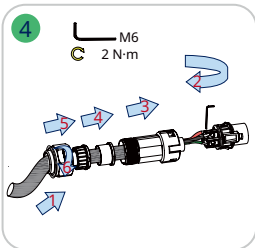
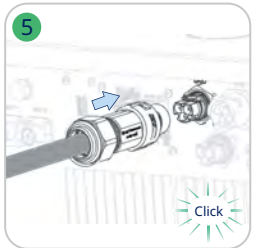
Procedure		
Step 1	<ul style="list-style-type: none"> • Remove the cable jacket by 20-25 mm, and strip the wire insulation by 7-8 mm. • The conductor cross-sectional area: 6 mm². 	
Step 2	<ul style="list-style-type: none"> • Unscrew the grid connector counterclockwise. • Disassemble the parts in sequence. 	
Step 3	<ul style="list-style-type: none"> • Insert the cable conductor core into the terminals and crimp them tightly. Make sure the cable jacket is not locked within the connector. • Thread the AC cable of appropriate length through the waterproof terminal. 	
Step 4	<ul style="list-style-type: none"> • Fix all cables to the corresponding terminals with a torque of 2 N·m using the screwdriver according to markings on the connector. Make sure the L/N/PE are correctly assembled. • Assemble the parts in sequence. 	
Step 5	<ul style="list-style-type: none"> • Tighten the waterproof terminal clockwise. • Connect the grid connector to the inverter. There should be a “click” sound, if it is plugged in correctly. 	

3.4.2.2 GEN Connection

The GEN port can be connected to the PV inverter or diesel generator, and the GEN port wiring method is the same as that described in “[3.4.2.1 Grid Connection](#)”.

The GEN port limits of connecting the inverter and generator are described as follows:

Inverter Model	INS-3.6LV-EUA1
Nominal Input Voltage of GEN Port (V)	230
Max. Input Current of GEN Port (A)	16
Recommended AC Breaker	20 A/230 V
Recommended Cable (mm ²)	6

Note:

- Select the appropriate AC breaker in accordance with local laws and regulations.
- The grid-connected PV inverter connected must have the function of overfrequency protection.



3.4.2.3 EPS Connection

The INS-3.6LV-EUA1 inverter has on-grid and off-grid function. The inverter will transmit power through the GRID port when the grid is on, and it will transmit power through the EPS port when the grid is off. A standard PV installation typically consists of connecting the inverter to both panels and batteries. When the system is not connected to the batteries, the manufacturer strongly advises that the backup function shall not be used. The manufacturer will not honor the standard warranty and will not be liable for any consequences arising from users not following this instruction.

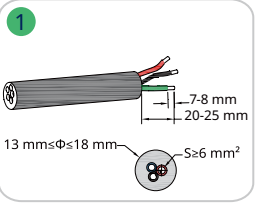
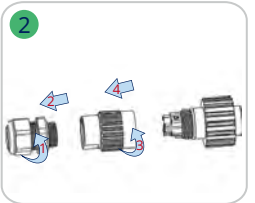
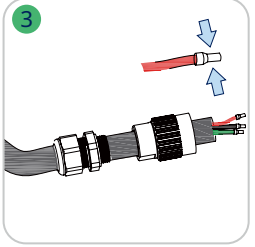
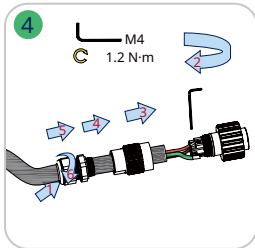
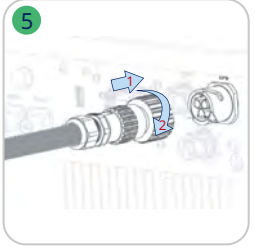
 WARNING	<ul style="list-style-type: none"> • Before connecting the EPS, please make sure all requirements listed below are followed. • Use the EPS connector from the accessory box. Damage to the device due to the use of an incompatible connector shall not be covered by the warranty. • An independent three or four-pole circuit breaker must be installed on the output side of the inverter to ensure safe disconnection from the grid. • Multiple inverters cannot share one circuit breaker. • Never connect a load between the inverter and the circuit breaker. • Make sure the EPS load power rating is within the EPS output rating, otherwise the inverter will shut down with an “overload” warning. • For the nonlinear load, please make sure the inrush power should be within the EPS output power range.
---	---

Procedure		
<p>Step 1</p>	<ul style="list-style-type: none"> Remove the cable jacket by 20-25 mm, and strip the wire insulation by 7-8 mm. The conductor cross-sectional area: $\geq 6 \text{ mm}^2$. 	
<p>Step 2</p>	<ul style="list-style-type: none"> Unscrew the EPS connector counterclockwise. Disassemble the parts in sequence. 	
<p>Step 3</p>	<ul style="list-style-type: none"> Insert the cable conductor core into the terminals and crimp them tightly. Make sure the cable jacket is not locked within the connector. Thread the AC cable of appropriate length through the waterproof terminal. 	
<p>Step 4</p>	<ul style="list-style-type: none"> Fix all cables to the corresponding terminals with a torque of 1.2 N•m using the screwdriver according to markings on the connector. Make sure the L/N/PE are correctly assembled. Assemble the parts in sequence. 	
<p>Step 5</p>	<ul style="list-style-type: none"> Tighten the waterproof terminal clockwise. Connect the EPS connector to the inverter and tighten it. 	

3.4.3 PV Wiring Connection

 <p>WARNING</p>	<p>Before connecting the PV, please make sure all requirements listed below are followed.</p> <ul style="list-style-type: none"> The voltage, current and power ratings of the panels to be connected are within the allowable range of the inverter. Ensure the polarity is correct, and please refer to the technical parameters in Chapter 5 for voltage and current limits. Since the inverter is a transformerless structure, please do not ground the outputs of PV panels. If the inverter is integrated with a PV switch, please make sure it is in the "OFF" position. Otherwise please use an external PV switch to cut off the PV connection during wiring and when necessary.
 <p>NOTICE</p>	<ul style="list-style-type: none"> Use the PV connectors in the accessory box for PV connections. Damage to the device due to the use of an incompatible terminal shall not be covered by the warranty. Please make sure the connectors are correct, not the battery connectors, as they look similar.

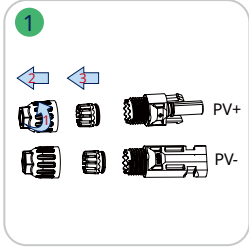
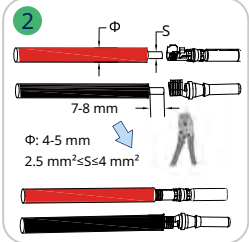
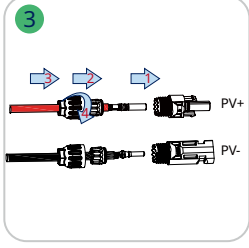
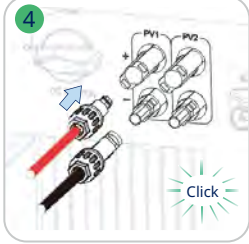

Procedure		
<p>Step 1</p>	<ul style="list-style-type: none"> Unscrew the PV connector counterclockwise. Remove the insulator. Remove the inner cable gland. 	
<p>Step 2</p>	<ul style="list-style-type: none"> Strip the insulation from each DC cable by 7-8 mm. The conductor cross-sectional area: 2.5-4 mm². Assemble cable ends with crimp contacts by PV terminal crimping tool. 	
<p>Step 3</p>	<ul style="list-style-type: none"> Lead the cable through the cable gland. Insert the crimp contact into the insulator until it snaps into place. Gently pull the cable backward to ensure a firm connection. Tighten the cable gland and the insulator. 	
<p>Step 4</p>	<ul style="list-style-type: none"> Check the cable connection of the PV string for polarity correctness and ensure that the open-circuit voltage in any case does not exceed the inverter input limit of 550 V. Connect the PV connectors to the inverter. There should be a "click" sound, if they are plugged in correctly. 	



3.4.4 Battery Wiring Connection

This section mainly describes the cable connections on the inverter side. Refer to the instructions supplied by the battery manufacturer for the connections on the battery side.

For batteries without a built-in DC breaker, make sure that an external DC breaker is connected.

If you need to use this hybrid inverter as a grid-tied inverter, please contact InstaGroup for help.

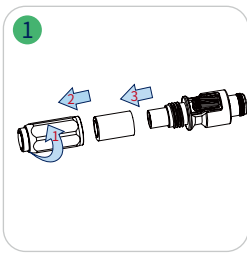
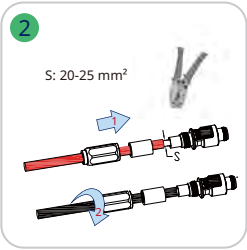
 WARNING	<ul style="list-style-type: none"> A two-pole DC breaker with (over current protection) OCP function is compulsory to be installed between the inverter and battery. The battery may have this switch integrated. If not, an external DC switch of proper ratings should be used. Make sure the breaker mentioned above is in the "OFF" position.
 NOTICE	<ul style="list-style-type: none"> Use the battery connectors in the accessory box for battery connections.

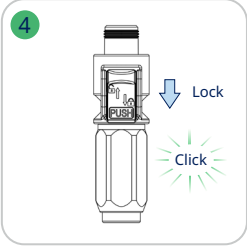
Procedure		
Step 1	<ul style="list-style-type: none"> Unscrew the battery connector counterclockwise. Remove the insulator. Remove the inner cable gland. 	
Step 2	<ul style="list-style-type: none"> Strip the insulation from each DC cable by 15-18 mm. The outer diameter of the battery cable is less than 10.2 mm. The conductor cross-sectional area: 20-25 mm². Assemble cable ends with crimp contacts by hydraulic pliers. 	
Step 3	<ul style="list-style-type: none"> Check the cable connection of the battery for polarity correctness and ensure that the open-circuit voltage in any case does not exceed the input limit of 60 V. Connect the battery connectors to the inverter. There should be a "click" sound if they are plugged in correctly. 	
Step 4	<ul style="list-style-type: none"> Push the button downward to lock the connection with a "click" sound. 	

3.4.5 Communication Wiring Connection

Detailed pin functions of each port on the communication interface are as follows.

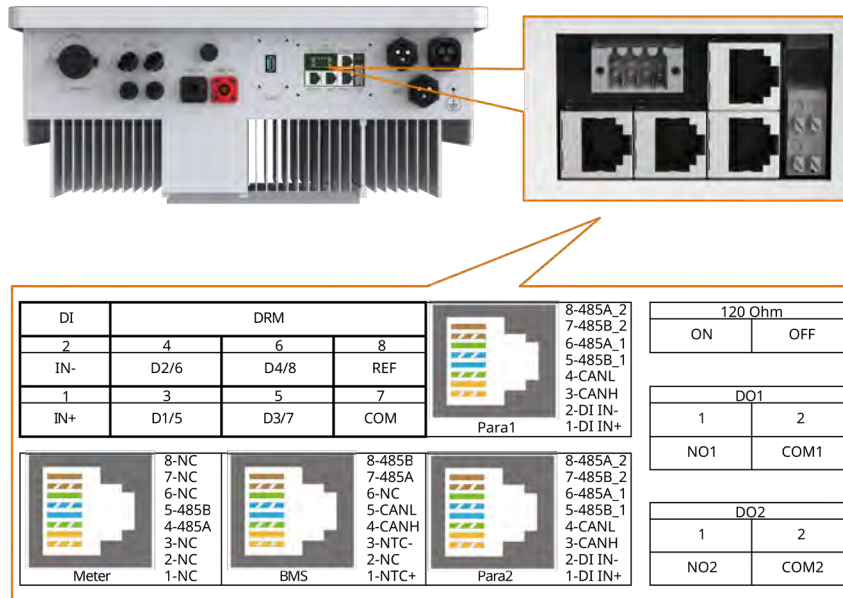

Label	Description
Meter (485A, 485B)	For the Smart Meter.
BMS (NTC+, NTC-, CANH, CANL, 485A, 485B)	For InstaGen LV Battery, communication is via CAN or RS485.
DRM (D1/5, D2/6, D3/7, D4/8, COM, REF)	For external Demand Response Enabling Device.
DI (IN+, IN-)	Dry contact input of external bypass contactor.
Parallel (DI IN+, DI IN-, CANH, CANL, 485B_1, 485A_1, 485B_2, 485A_2)	For parallel operation.
120 Ohm (ON, OFF)	120 Ohm termination resistor for parallel operation.
DO1 (NO1, COM1)	Dry contact output. The DO1 can be set to one of the functions as follows: Earth Fault Alarm, Load Control and Generator Control.
DO2 (NO2, COM2)	Dry contact output. The DO2 will control the bypass contactor under certain logic.

3.4.5.1 BMS Connection

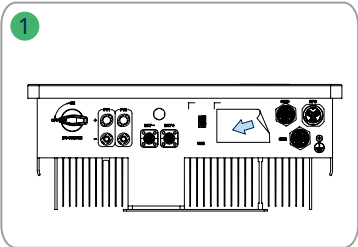
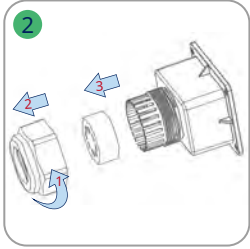
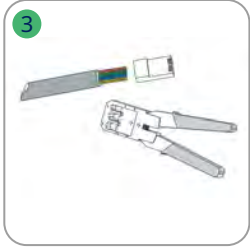
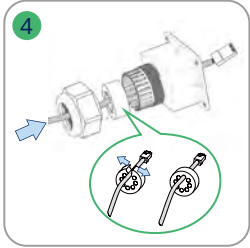
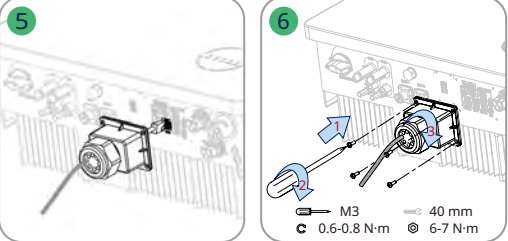

BMS is used to communicate with the compatible InstaGen LV Battery.

 <p>NOTICE</p>	<ul style="list-style-type: none"> • Connection of communication box is mandatory whether it is wired or not.
---	--

Procedure		
Step 1	<ul style="list-style-type: none"> • Peel the stickers off from the communication port. 	
Step 2	<ul style="list-style-type: none"> • Unscrew the communication box counterclockwise. • Disassemble the parts in sequence. 	
Step 3	<ul style="list-style-type: none"> • Strip the insulation layer of the communication cable with an ethernet wire stripper, and lead the corresponding signal cables out. Insert the stripped communication cable into the RJ45 plug in the correct order, and crimp it with a network cable crimper. • The pin definitions of BMS or battery temperature sensor are shown in "3.4.5 Communication Wiring Connection". 	
Step 4	<ul style="list-style-type: none"> • Thread the cable of an appropriate length through the communication box. • Clip the Ethernet cable into the rubber ring. 	
Step 5&6	<ul style="list-style-type: none"> • Insert the RJ45 plug into the BMS port until it clicks into place. • Tighten the cable gland. • Install communication box with screws. • Connect the other end of the BMS cable to the battery, following the battery's manual instructions. 	

3.4.5.2 Smart Meter and CT Connection

The smart meter and CT in the accessory box are necessary for system installation, and are used to provide the operating condition of the inverter via RS485 communication.

 WARNING	<ul style="list-style-type: none"> Before connecting the smart meter and CT, ensure that the AC cable is totally isolated from the AC power source.
 NOTICE	<ul style="list-style-type: none"> One smart meter can be used with only one inverter. One CT must be used for one smart meter and must be connected on the same phase with the smart meter power cable. There is a symbol (arrow) or label on the surface of CT that indicates the correct mechanical orientation of the CT on the conductor under measurement. Please identify the arrow or label before installing the CT. Two smart meters are required for the installation of AC-coupled system. There is one smart meter in our packing box, and the other needs to be purchased from InstaGroup. The meter address is automatically set. If there are meter communication problems, please check if the address of the PV side meter is set to 1, and the address of the grid side meter is set to 2.

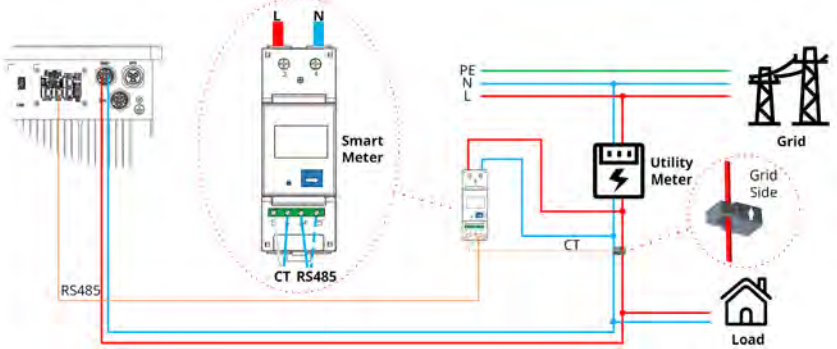
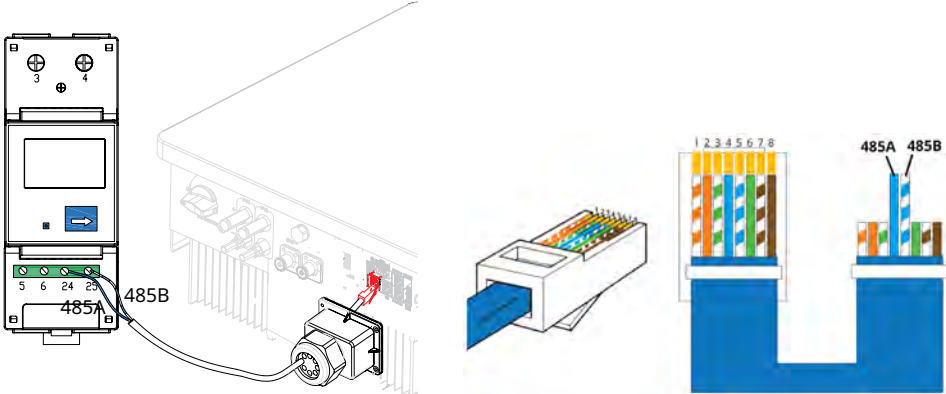
Procedure	
Step 1	<ul style="list-style-type: none"> Connect grid L/N to meter's terminals 3/4. Clamp CT to L line and connect wirings to 5/6 respectively. The arrow on the surface of CT should point to the grid. 
Step 2	<ul style="list-style-type: none"> Connect the communication cable between the inverter and smart meter. 

3.4.6 DTS Connection

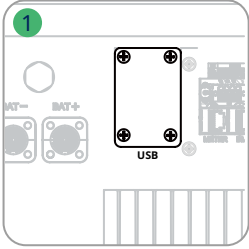
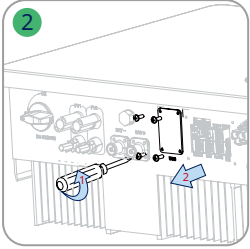
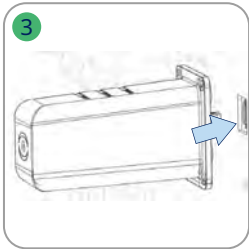
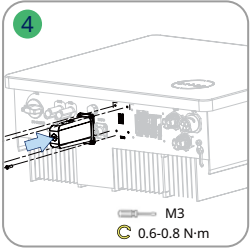
DTS-WIFI-G1 Procedure		
<p>Steps</p> <ul style="list-style-type: none"> • Remove the DTS port cover plate. • Insert the DTS into the USB port. • Fasten the screws. 		
		

Indicator	Status	Description
RUN	ON	DTS is powered on.
	OFF	DTS is not powered on.
COM	ON	Proper communication with the inverter.
	OFF	Improper communication with the inverter.
NET	ON	Proper communication with Insta Cloud.
	OFF	Improper communication with Insta Cloud.
	BLINK	Improper communication with Insta Cloud, but the network is connected.

3.5 Operation

3.5.1 Commissioning

	<p>Before the commissioning of inverter, make sure:</p> <ul style="list-style-type: none"> • The inverter DC switch and external circuit breaker are disconnected; • Check wiring according to "3.4 Electrical Wiring Connection"; • Check whether the grid voltage is within the permissible range though the multimeter before turning on the AC switch; • Unused terminals must be sealed using the corresponding sealing plugs; • Nothing is left on the top of the inverter and battery; • Cables are routed in a safe place or protected against mechanical damage; • Warning signs and labels are intact.
---	---

System Power-on Procedure	
Step 1	If the inverter is connected to the battery, turn on the battery power switch and DC breaker.
Step 2	Turn on the AC breaker between the inverter and the grid.
Step 3	Rotate the DC switch to "ON" if the inverter is connected to the PV strings.
Step 4	Check whether the inverter is operating properly through the inverter indicators status.

3.5.2 Decommissioning

	<p>After powering off the inverter, follow the steps below if needed:</p> <ul style="list-style-type: none"> • Wait at least 10 minutes after the LED indicators turn off to release the internal energy; • Disconnect all cables; • Remove DTS and power meter; • Remove the inverter from the wall, remove the bracket if necessary, and finally pack the inverter and accessories. <p>Please strictly follow the procedure below. Otherwise it will cause lethal voltages or unrecoverable damage to the inverter.</p>
---	---

System Power-off Procedure	
Step 1	Stop the inverter from working via the InstaGen App.
Step 2	Disconnect the AC breaker between the inverter and the grid.
Step 3	Rotate the DC switch to "OFF" if the inverter is connected to the PV strings.
Step 4	Turn off the DC breaker between the inverter and the battery.
Step 5	Check whether the inverter indicators are off.

4. Troubleshooting

When the system is in alarm, please log into the Insta Cloud App to review. The possible causes and their troubleshooting are detailed in the following table:

Display	Possible Cause	Handling Suggestions
Grid Overvoltage	The grid voltage is higher than the permissible range.	Generally, the inverter will reconnect to the grid after the grid recovers. If the alarm occurs frequently: 1. Make sure the ESS safety configuration of the inverter is set correctly. 2. Make sure that the grid voltage in your area is stable and within the normal range. 3. Check whether the cross-sectional area of the AC cable meets the requirement. 4. If the alarm persists, contact InstaGroup technical support team.
Grid Undervoltage	The grid voltage is lower than the permissible range.	Generally, the inverter will reconnect to the grid after the grid recovers. If the alarm occurs frequently: 1. Make sure the ESS safety configuration of the inverter is set correctly. 2. Make sure that the grid voltage in your area is stable and within the normal range. 3. Check whether the AC cable is firmly in place. 4. If the alarm persists, contact InstaGroup technical support team.
Grid Overfrequency	The grid frequency is higher than the permissible range.	Generally, the inverter will reconnect to the grid after the grid recovers. If the alarm occurs frequently: 1. Make sure the ESS safety configuration of the inverter is set correctly. 2. Make sure that the grid frequency in your area is stable and within the normal range. 3. If the alarm persists, contact InstaGroup technical support team.
Grid Underfrequency	The grid frequency is lower than the permissible range.	
No Grid	The inverter detects that there is no grid connected.	Generally, the inverter will reconnect to the grid after the grid recovers. If the alarm occurs frequently: 1. Check whether the grid supply is reliable. 2. Check whether the AC cable is firmly in place. 3. Check whether the AC cable is correctly connected. 4. Check whether the AC circuit breaker is disconnected. 5. If the alarm persists, contact InstaGroup technical support team.
RCD Fault	The residual leakage current is too high.	1. The alarm can be caused by high ambient humidity, and the inverter will reconnect to the grid after the environment is improved. 2. If the environment is normal, check whether the AC and DC cables are well insulated. 3. If the alarm persists, contact InstaGroup technical support team.
PV Reverse Connection	The inverter detects that the PV strings are reversely connected.	1. Check whether the corresponding string is of reverse polarity. If so, disconnect the DC switch and adjust the polarity when the string current drops below 0.5 A. 2. If the alarm persists, contact InstaGroup technical support team.
PV Undervoltage	The PV voltage is lower than the permissible range.	1. Check whether the DC cable is firmly in place. 2. Check whether there is a PV module shaded. If so, remove the shade and ensure the PV module is clean. 3. Check whether the PV module is in abnormal aging. 4. If the alarm persists, contact InstaGroup technical support team.
PV Overvoltage	The PV voltage is higher than the permissible range.	1. Check the specification and numbers of corresponding string PV modules. 2. If the alarm persists, contact InstaGroup technical support team.

Display	Possible Cause	Handling Suggestions
Over Temperature	The temperature inside the inverter is higher than the permissible range.	<ol style="list-style-type: none"> 1. Make sure that the installation complies with the instructions from User Manual. 2. Check whether the alarm "Fan Fault" occurs. If so, replace the faulty fan. 3. If the alarm persists, contact InstaGroup technical support team.
ISO Fault	The insulation impedance of the PV string to the ground is too low.	<ol style="list-style-type: none"> 1. Use a multimeter to determine if the resistance between the earth and the inverter frame is close to zero. If not, please ensure that the connection is good. 2. If the humidity is too high, an isolation fault may occur. Attempt to restart the inverter. If the fault persists, check it again when the weather turns fine. 3. Check the resistance to ground from the PV module/ cable. Take corrective measures in case of leading to a short circuit or damaged insulation layer. 4. If the alarm persists, contact InstaGroup technical support team.
Arc Fault	The inverter detects that there is an arc fault.	<ol style="list-style-type: none"> 1. Disconnect the DC switch and check whether DC cables are damaged and whether the wiring terminals are loose or in poor contact. If so, take corresponding corrective measures. 2. After taking corresponding measures, reconnect the DC switch. 3. If the alarm persists, contact InstaGroup technical support team.
EPS Load Overpower	The EPS load power is higher than the permissible range.	<ol style="list-style-type: none"> 1. Reduce the power of EPS loads, or remove some EPS loads. The inverter will restart automatically. 2. If the alarm persists, contact InstaGroup technical support team.
Meter Reverse Connection	The inverter detects that the Meter or CT is reversely connected.	<ol style="list-style-type: none"> 1. Make sure that the installation complies with the instructions from User Manual. 2. If the alarm persists, contact InstaGroup technical support team.
Meter Communication Fault	The inverter detects that there is a meter communication fault.	<ol style="list-style-type: none"> 1. Check whether the Meter communication cable and terminal are abnormal. 2. Reconnect the Meter communication cable. 3. If the alarm persists, contact InstaGroup technical support team.
Battery Reverse Connection	The inverter detects that the battery wirings are reversely connected.	<ol style="list-style-type: none"> 1. Check the battery for polarity correctness, and correct it if necessary. 2. If the alarm persists, contact InstaGroup technical support team.
Battery Voltage Fault	The battery voltage is higher than the permissible range.	<ol style="list-style-type: none"> 1. Check if the battery input voltage is within the normal range. 2. If the alarm persists, contact InstaGroup technical support team.
BMS Communication Fault	The inverter detects that there is a BMS communication fault.	<ol style="list-style-type: none"> 1. Check whether the BMS communication cable and terminal are abnormal. 2. Reconnect the BMS communication cable. 3. If the alarm persists, contact InstaGroup technical support team.

Display	Possible Cause	Handling Suggestions
BMS Battery Alarm	The inverter detects that there is a battery fault from BMS.	Try to restart the battery. If the fault persists, contact the battery manufacturer.
BMS Battery Fault	The inverter detects that there is a battery fault from BMS.	Try to restart the battery. If the fault persists, contact the battery manufacturer.
Relay Self-check Fault	The inverter detects that there is a relay self-check fault.	Try to restart the inverter. If the fault persists, contact InstaGroup technical support team.

5. Technical Datasheet

Model	INS-3.6LV-EUA1
Battery	
Battery Type	InstaGen LV Battery
Nominal Battery Voltage (V)	48
Voltage Range (V)	40-60
Max. Charge Current (A)	90
Max. Discharge Current (A)	90
Charging Strategy for Li-ion Battery	Self-adaption to BMS
Charging Curve	3 Stages / Equalization
External Temperature Sensor	Optional
PV Input	
Max. PV Input Power (W)	6000
Max. PV Input Voltage (V)	550
Nominal Input Voltage (V)	360
MPPT Voltage Range (V)	125-500
Start-up Voltage (V)	150
Number of MPPTs	2
Max. Number of PV String per MPPT	1/1
Max. PV Input Current (A)	14/14
Short-circuit Current of PV Input (A)	17/17
AC Input and Output (On-grid)	
Nominal Output Apparent Power (VA)	3680
Max. Output Apparent Power (VA)	3680
Max. Input Apparent Power (VA)	7360
Nominal AC Voltage (V)	230
Nominal Grid Frequency (Hz)	50/60
Max. Output Current (A)	16.0
Max. Input Current (A)	32.0
Power Factor	0.8 leading ... 0.8 lagging
Total Harmonic Distortion (@nominal output)	<3%
AC Output (Off-grid)	
Max. Output Apparent Power (VA)	3680
Peak Output Apparent Power (VA) ⁽¹⁾	7360, 10s
Nominal AC Voltage (V)	230
Nominal AC Frequency (Hz)	50/60
Max. Output Current (A)	16.0
Total Harmonic Distortion (@ linear load)	<3%
Efficiency	
Max. Efficiency	97.6%
Euro Efficiency	97.0%
Max. Battery to Load Efficiency	95.0%
MPPT Efficiency	99.9%
Protection	
Anti-islanding Protection	Integrated
PV String Input Reverse Polarity Protection	Integrated
Insulation Resistor Detection	Integrated
Residual Current Monitoring Unit	Integrated
AC Over Current Protection	Integrated
AC Short Current Protection	Integrated
AC Overvoltage and Undervoltage Protection	Integrated
Surge Protection	DC Type II / AC Type III
General	
Dimension (W × H × D [mm])	502 × 461 × 202
Weight (kg)	24
Mounting	Wall Mounting
Operation Temperature (°C)	-25 to + 65 (>45, derating)
Relative Humidity	0-95%, no condensing
Altitude (m)	≤2000
Cooling	Natural Convection
Protection Degree	IP65
Noise (dB [A])	<40
User Interface	LED & App
Communication with BMS	RS485, CAN
Communication with Meter	RS485
Communication Interface	RS485, Wi-Fi/Ethernet/4G (optional)
Digital Input/Output	DRM, 1 × DI, 2 × DO
Isolation Method (Solar / Battery)	Transformerless / High-frequency Isolation
Certifications and Standards	
Safety Regulation	IEC 62109-1, IEC 62109-2
EMC	EN 61000-6-1, EN 61000-6-3

(1) Can be achieved only if PV and battery power are sufficient.

Insta House, Ivanhoe Road, Hogwood Business Park, Finchampstead,
Wokingham, Berkshire, RG40 4PZ, UK.
0800 526 023

General inquiry: info@instagroup.co.uk

Visit <https://www.instagroup.co.uk/> for more information.