

String Inverter (33KTL)



SUN2000-33KTL



Smart

- Maximum of 3 MPPT for versatile adaption to different module types or quantities built up with different alignments
- Up to 6 strings intelligent monitoring and fault detection
- Wireless communication network
- LED status indication

Efficient

- Maximum efficiency 98.6%
- European efficiency 98.3%

Safe

- Type II DC and AC surge protection devices integrated
- Easy to handle with weight of 50kg by 2 people
- RCD protection function

Reliable

- Warranty up to 25 years
- No need of external fan with natural cooling technology
- Outdoor application of IP65

Efficiency Curve

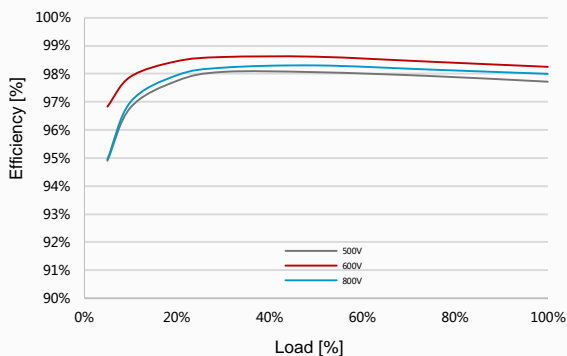

Circuit Diagram

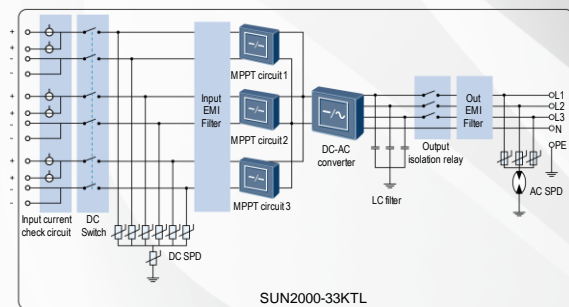

String Inverter (33KTL)



Technical Specifications	SUN2000-33KTL
	Efficiency
Max. efficiency	98.6%
European efficiency	98.3%
	Input
Max. DC input	33,800 W
Max. input voltage	1000 V
Max. input current per MPPT	23 A
Max. short circuit current per MPPT	32 A
Operating voltage range	200 V - 980 V
MPP voltage range at full loading	480 V - 800 V
Rated input voltage	620 V
Max. number of inputs	6
Number of MPP trackers	3
	Output
Rated AC output power	30,000 W
Max. apparent output power	33,000 VA *
Rated output voltage	220V - 230V, 3W+N+PE / 380V - 400V, 3W+N+PE
AC power frequency	50 Hz / 60 Hz
Max. output current	48 A
Adjustable power factor	0.9 leading ... 0.9 lagging
Max. total harmonic distortion	< 3%
	Protection
Input-side disconnection device	Yes
Anti-Islanding protection	Yes
AC over current protection	Yes
DC reverse-polarity protection	Yes
PV-array string fault monitoring	Yes
DC surge arresters	Type II
AC surge arresters	Type II
Insulation monitoring	Yes
Residual current detection	Yes
	Display and Communication
Display	LED Indicators
RS485	Yes
USB	Yes
PLC	Optional
Bluetooth + APP	Yes
	General Data
Dimensions (W/H/D)	550×770×270 mm
Weight	50 kg
Operating temperature range	-25 °C to +60 °C
Cooling	Natural convection
Operating altitude	4000 m
Relative humidity (non-condensing)	0 - 100%
DC connector	Amphenol H4
AC connector	Waterproof PG terminal + OT connector
Degree of protection	IP65
Self-consumption at night	< 1 W
Topology	Transformerless
Noise emission	33 dB
Warranty	5 years, 10/15/20/25 years optional
	Standards Compliance
Safety/EMC	EN61000-6-2, EN61000-6-3, EN61000-3-11, EN61000-3-12, EN/IEC62109-1, EN/IEC62109-2
Grid Code	VDE-AR-N4105, VDE0126-1-1, BDEW 2008, Enel-Guideline, CEI 0-21, CEI 0-16, G59/3, G83/2, AS4777, CGC/GF004:2011, NB/T 32004-2013, UTE C 15-712-1, C10/11, IEC61727, IEC62116, RD1669, EN50438, MEA 2013, PEA 2013, GB/T 19964-2012

* Max. Output 33kVA at 25 °C, output 30kVA at 40 °C

Always Available for Highest Yields

info.energyeu@huawei.com
 inverter@huawei.com
 Tel: 49 911 255 22 3053
 Tel: 800 0889977