



Quick Installation Guide For SPA Series

Step1. General information-Specification

The type of product	SPA Series
AC output/input data	
AC nominal voltage	230V/50Hz
AC nominal power	1000W/2000W/3000W
Power factor	0.8leading-0.8lagging
Stand alone	
AC nominal output power	1000W/2000W/3000W
Rated output voltage	230V/50Hz
Battery data	
Battery voltage range	42-59Vdc
Max charge and discharge current	24A/44A/66A
Type of battery	Lead-acid and lithium
Environment	
Operating temperature range	-25°C~+60°C
Degree of protection	IP 65
Grid regulation	CEI0-21, G98, G100, AS/NZS 4777.2, VDE-AR-N4105, VDE 0126-1-1, EN50438, TR3.3.1, IEC62116, IEC61727, UTE C 15-712
EMC	EN 6 1000-6-1, EN6 1000-6-3
Safety	IEC62477-1, IEC 62040-1

Step2. General information-Parts List

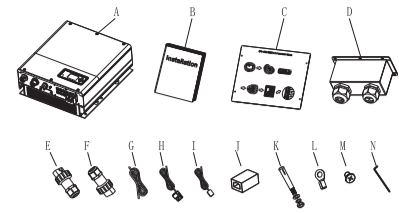

Item	Number	Description
A	1	SPA Series (we describe this series as "SPA" as below)
B	1	User Manual
C	1	Paper Board (Installation Guide)
D	1	Waterproof Cover
E	1	Online Grid Connector
F	1	Offline Grid Connector
G	2	Communication Cable
H	2	Current Sensor from grid to load and from grid to inverter
I	1	Lead-acid Battery Temperature Sensor
J	2	RJ 45 Connector
K	4	M6 setscrew
L	2	Battery power terminal
M	6	Screw
N	1	Hex screwdriver

Step3. Key Features

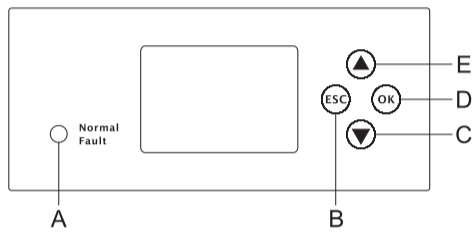

Location	Description
A	Status
B	ESC-button (cancel control)
C	Down-button
D	Enter-button
E	UP-button

Description	Explanation	
Push-button	Operation of display screen and set system	
Status symbol of SPA	Green light on	SPA run normally
	Red light on	Fault state
	Green light blinking	Alarm state
	Red light blinking	Software updating

Step4. Installation

1. System overview

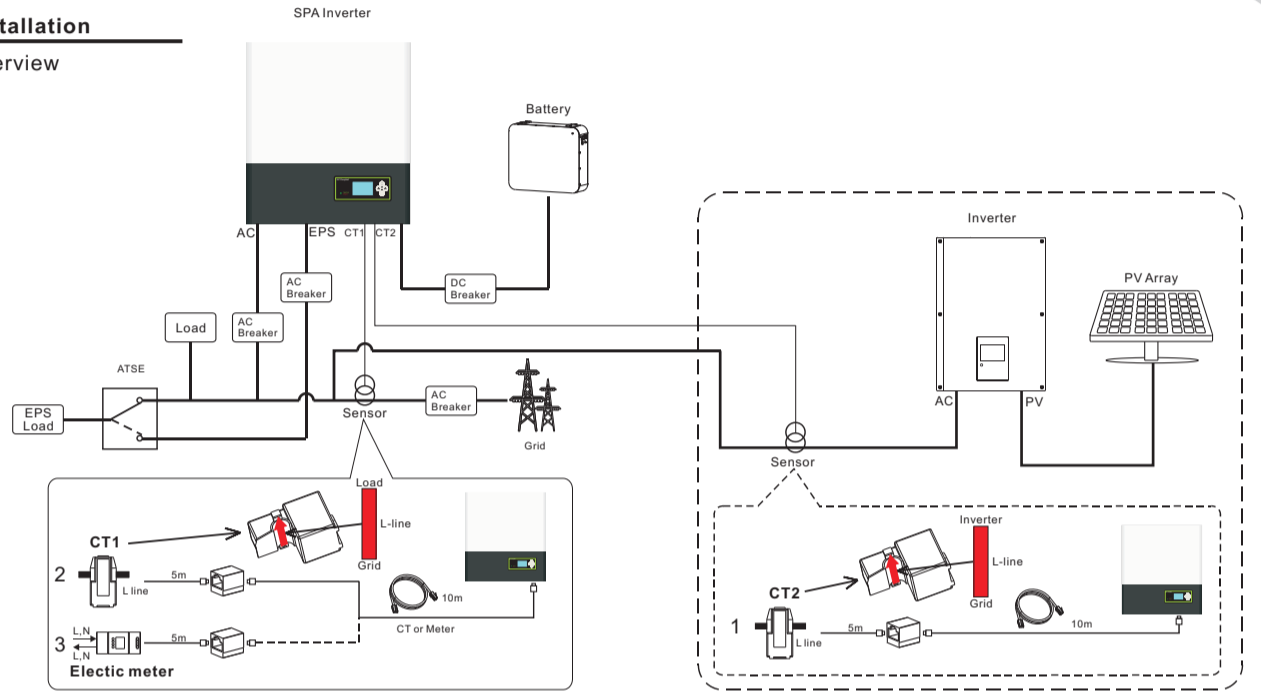

2. The Ingress Protection rate is IP65 and the pollution degree is PD2. Please refer to the below:



3. Installation space for SPA, Please refer to below:

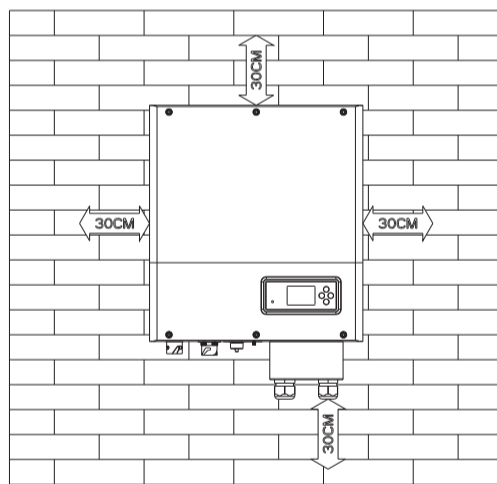

4. Follow installation guide to install SPA:

SPA 1000-3000TL BL Installation Guide

- Please make sure that the thickness of the wall for inverter installation is more than 60mm;
- Please place the bitmap horizontally on the wall and confirm the level by level;
- Please mark the holes in the 4 mounting holes of hole pattern;
- Drill a hole with a depth of 55mm at the mark with a drill of $\phi 8\text{mm}$;
- Please expand the bolt with a hammer into the hole in the wall and install the nut (including elastic flat pad), do not tighten the nut.
- Please hang the inverter on the expansion bolt and tighten the nut with a wrench.

200mm (7.87inch)
395mm (15.5inch)

5. Connection of AC terminal and off grid terminal, SPA have two terminal of AC, one is for on grid connect, and the other one is used for off grid (back up power supply):

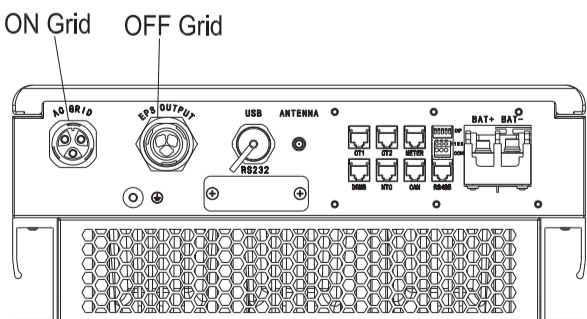

Both on grid and off grid terminal tied like follow:

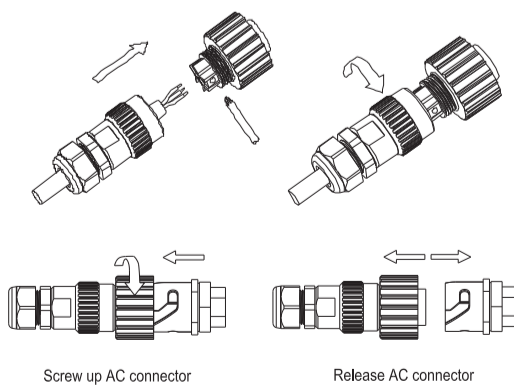

Notice:

- On grid terminal and off grid terminal can't directly connect together, if directly connected together, it will cause damage to SPA!
- Off Grid terminal can't connect to grid. If there is grid power, it will cause damage to SPA!

6. Connection of battery terminal:

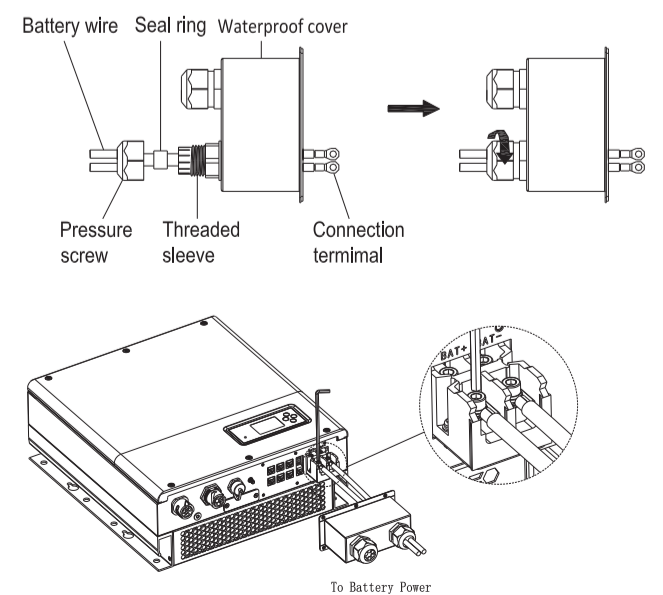

7. Connection of communication terminal for lithium battery:

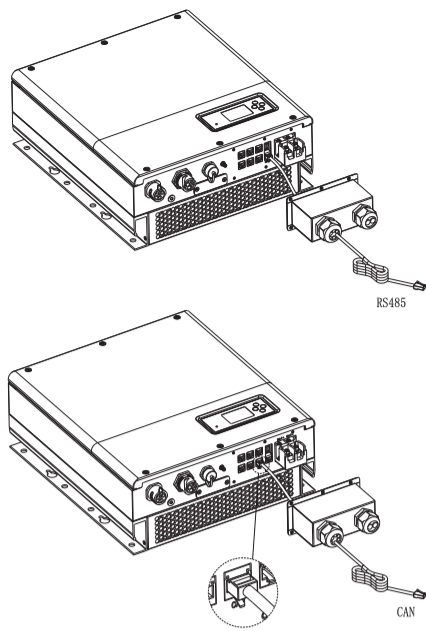

Notice:

If you are using a lead-acid battery, you do not need to install this communication cable.
 1. The CAN battery communication and RS485 battery communication can't be installed at same time, please select the correct communication method according to the battery manual.
 2. If the cable such as "RS485" cable or "CAN" cable is not used, please do not remove the filler plug from the cable support sleeve.

8. Connection of temperature probe for lead-acid battery
 If you try a lead-acid battery instead of a lithium battery, you should connect the temperature sensor of lead-acid battery like follow, the length of this cable is 1.5m, so please pay attention to the distance of battery and SPA.

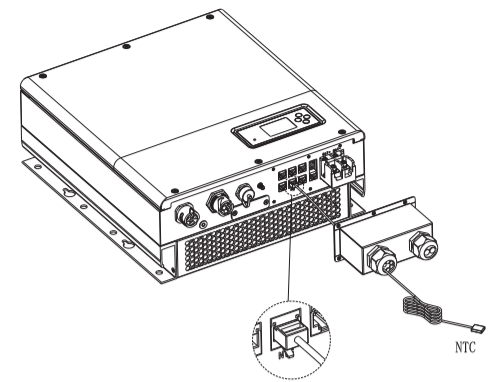

9. Connection of CT1/CT2 terminal :

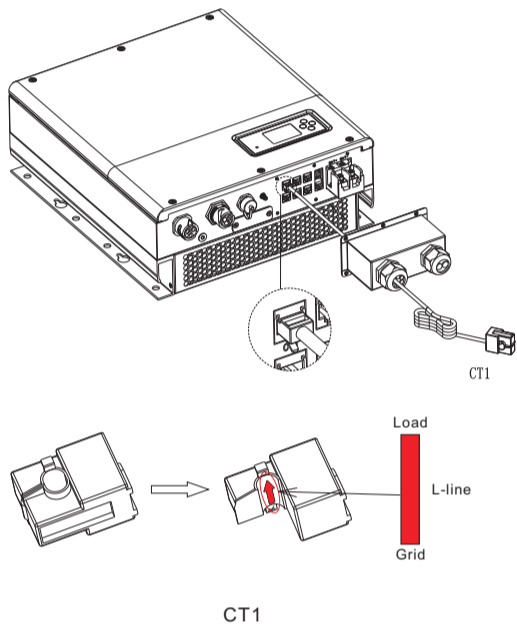

Pay attention of the direction of sensor, As illustrated below, open the current transformer and you can see an arrow labeled on it indicating the direction of current. The direction of arrow of CT1 means from public grid to user load and the direction of arrow of CT2 means from public grid to inverter if the SPA and existing inverter are installed in combination.

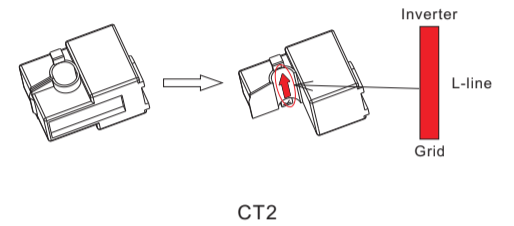
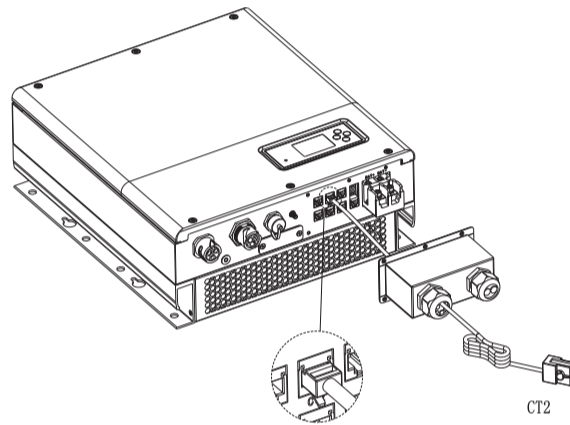

Notice:

1. We can change CT1 with meter which provided by Growatt to monitor the system energy.
2. If you change CT1 with meter, please plug in RJ45 of meter into "meter", and set sensor as "Meter".
3. We use CT1 to detect the current from grid to the load and use CT2 to detect the current from grid to inverter Installed in combination with SPA.
4. Please do not disconnect the RJ45 terminal of CT when CT is detecting current.

10. Grounding connection

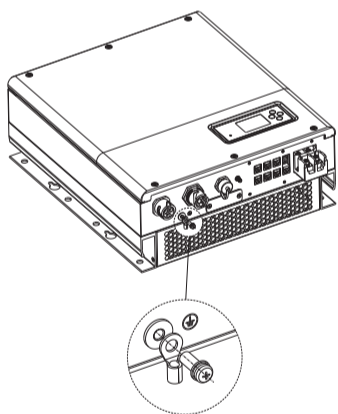

The SPA's monitoring

The SPA provide RS232 interface. Users can use the following communication solution to monitor the SPA (please make sure PIN1 and PIN2 are ON).

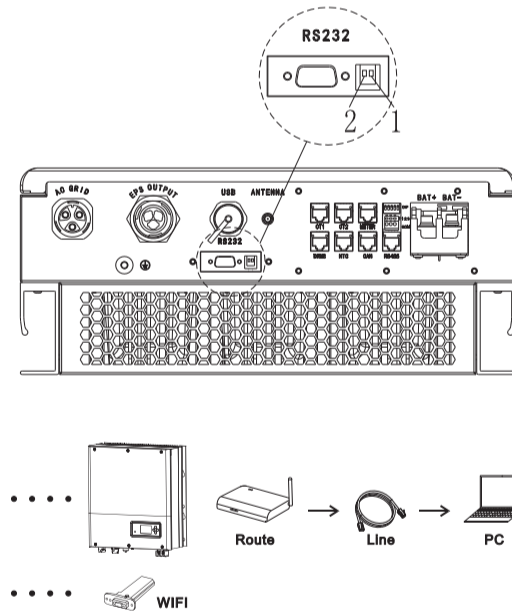

Notice:

This kind of monitoring, can only be used by the monitor of Growatt's Shine server software provided by the company.

Step5. Trouble shooting

Please turn to "Installation manual of SPA series" section nine.

Step6. Special function settings

We have the default work mode of SPA, if you want to change the work mode you can set up the SPA inverter by pushing button or using Shine server. How to setup? Please turn to "Installation manual of SPA series" section 6.4.4. We can set up the work mode of SPA and provide you with the best experience!



Download Manual



Growatt New Energy

Shenzhen Growatt New Energy Technology CO.,LTD
 No.28 Guangming Road, Shiyan Street, Bao'an District, Shenzhen, P.R.China
 T +86 0755 2747 1942
 E service@ginverter.com
 W www.ginverter.com
 GR-UM-147-A-00