

Residential Energy Storage User Manual

6.5kWh Energy Storage System (V1.1)

About this Document

Purpose

This document describes the installation, electrical connection, operation, commission, maintenance and troubleshooting of 6.5kWh Energy Storage System (hereinafter simply put 6.5kWh PACK or PACK). Before installing and operating 6.5kWh PACK, ensure that you are familiar with product features, functions, and safety precautions provided in this document.

Symbols



Symbol	Description
 WARNING	Indicates a potentially hazardous situation, if not avoided, could result in serious injury or death.
 CAUTION	Indicates a potentially hazardous situation, if not avoided, may result in serious injury or death.
 NOTICE	Indicates a potentially hazardous situation, if not avoided, could result in equipment damages, data loss, performance deterioration or unanticipated results. NOTICE is used to address practices not related to personal injury.

Table of Contents

About this Document	1
1 Product Overview	3
1.1 Intended Use	3
1.2 Appearance.....	4
1.3 Working Principle and Function.....	5
2 Safety	6
2.1 General Safety.....	6
2.3 Warning Labels	6
2.4 Precautions for PACK	8
2.5 Emergency Responses.....	8
3.1 Transportation Requirement.....	10
3.2 Storage Requirements	10
4 Installation.....	12
4.1 Basic Installation Requirements.....	12
4.2 Installation Required Tools	13
4.3 Installation Procedures.....	14
4.4 Electrical Connection	17
4.5 Installation Steps under Parallel Connection	20
5 Power on and Power off.....	22
5.1 Power-on Commissioning	22
5.2 Power off PACK.....	23
6 Maintenance Guide	24
6.1 Preparation	24
6.2 PACK Replacement.....	24
6.3 Software Upgrade	24
6.4 System Failure Information List and Troubleshooting Suggestions	25
7 Technical Specifications.....	28
Appendix I	29

1 Product Overview

1.1 Intended Use

As 6.5kWh LiFePO4 battery pack, One 6.5kWh PACK consists of 64Ah cells which form 48V voltage battery module via two parallel and sixteen serial connection (2P16S). Multiple 6.5kWh PACKs can be connected in parallel and extend the capacity and power of energy storage system. Specifically, the energy storage system chooses 6.5kWh PACKs to power loads at nighttime with no PV available; when PV becomes available during daytime, PV energy powers loads as a priority and store residual PV in 6.5kWh PACKs.

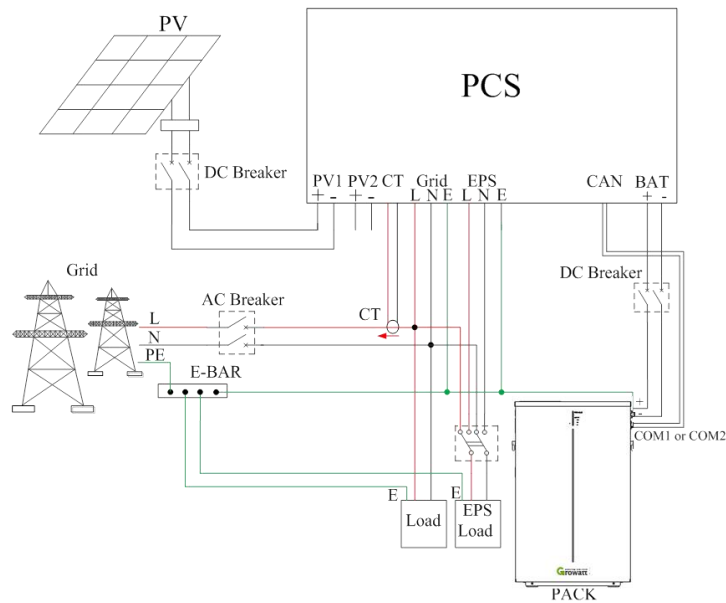

Figure 1: Typical Energy Storage System (Single PACK Application)

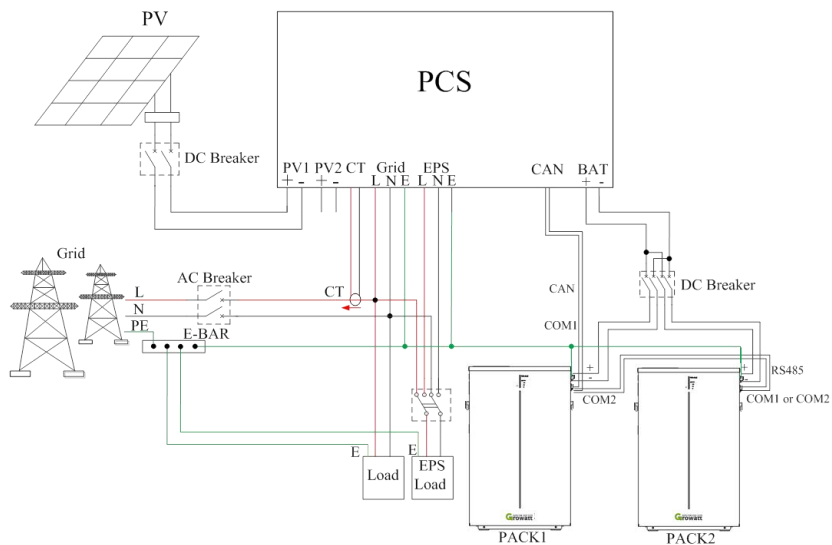
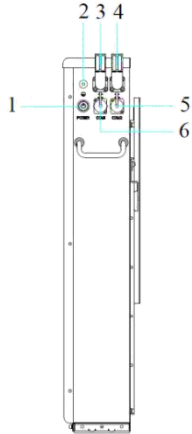

Figure 2: Typical Energy Storage System (Parallel Application)

1.2 Appearance

PACK consists of battery module (including cell and mechanical parts), battery management system (BMS) as well as power and signal terminals. Product appearance is shown as three views below.

Figure 3: Side View



Location	Port	Function
1	POWER button	A button to turn on/off the PACK
2	GND wiring terminal	A terminal to connect with ground.
3	Positive wiring terminal	The terminal stands for the PACK cathode output.
4	Negative wiring terminal	The terminal stands for the PACK anode output.
5	Communication interface	Two communication ports.
6		

Figure 4: Top View

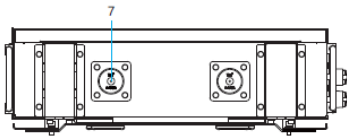

Location	Port	Function
7	Safety vent	Pressures inside is released via the vent.

Figure 5: Front View

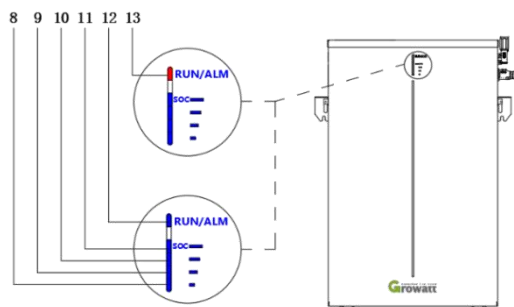

No.	Name	Color	Description
8	LED1	Blue	0%-40% SOC
9	LED2	Blue	41%-60% SOC
10	LED3	Blue	61%-80% SOC
11	LED4	Blue	81%-100% SOC
12	RUN	Blue	Blue RUN light indicates a normal operation.
13	ALM	Red	Red ALM light indicates a failure or protection status.

Figure 6: Dimension (unit: mm)

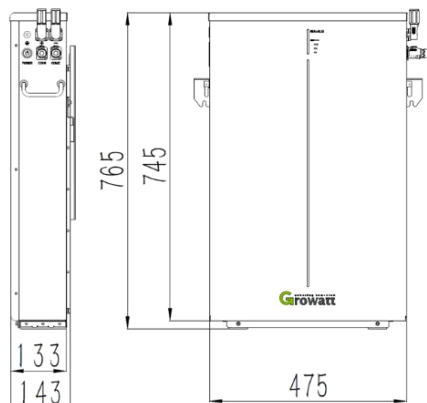

1.3 Working Principle and Function

PACK is an energy storage unit composed of electrochemical cells, battery management unit, power and signal terminals, and mechanical parts. It features better charge and discharge performance, more precise status monitor, longer service life, and less self-discharge loss than ordinary batteries. Specifically, the PACK built-in battery management system (BMS) monitors its operation and prevents the battery from working outside design limits; two PACKs connected in parallel can increase the capacity and power of battery system; the whole battery system communicates to Power Conversion System (PCS) via CAN.



- Monitoring: detect the voltage, current and temperature of both single cells and PACK.
- Alarm: alarm when overvoltage, under voltage, overcurrent, over-temperature or under temperature occurs.
- Protection: protect against over voltage, under voltage, over current, over temperature, under temperature, cell fault and hardware failure.
- Report: report all alarm and status data via CAN and RS485 communication to PCS.
- Parallel connection: support two PACKs in parallel connection.
- Passive balance function.
- Recognize identification via various hardware and software version label.
- Power off triggered by fault: PACK and PCS communication drop for 60 minutes, and three level under voltage protection.
- Forced power off: power off PACK by pressing switch for two seconds when PACK does not connect to main power supply.
- Activate: input 45V~60V on terminal P+/P- of main circuit and PACK can be activated. After that, PACK enters standby from off mode.

2.1 General Safety

The PACK has been designed and tested in strict compliance with international safety regulations. Read all safety instructions carefully prior to any work and observe them at all times when working on or with the PACK. Growatt will not be liable for any consequence caused by the violation of the following safety operation regulations and design, production, and usage standards:



- Damage caused by transportation
- Incorrect transportation, storage, installation or use, or customer fails to convey sufficient information about correct transportation, storage, installation or use to end users
- Installation by unqualified personnel
- Failure to comply with the operation instructions and safety precautions in this document
- Operation in extreme environments which are not covered in this document
- Unauthorized modifications to the PACK or software code or removal of the PACK
- PACK labels for exclusive purpose of disassemble protection are damaged or product with any part missing (excerpt the authorized disassemble parts).
- Repair, disassemble, or change PACKs without authorization and cause failure.
- Anybody brings harm to or burns shell labels, or modifies date of production.
- Inconsistency between the number on PACK label and PACK model, as well as that between the number specified in Warranty and PACK model.
- Counterfeited or fake PACK.
- PACKs fail to receive charging six month after being outputted for transportation.
- Device damages due to force majeure (such as lightning, earthquakes, fire, and storms)
- Warranty expiration without extension of the warranty service

2.3 Warning Labels

Symbols	Description
	Do not dispose in trash.
	Please recycle Lithium ion battery. Do not discard.



	Certification in European union area.
	Electric shock hazard.
	Explosive gas.
	The Pack may leak corrosive electrolyte.
	The Pack is heavy enough to cause severe injury.
	Keep the Pack away from children.
	Make sure that the battery polarity is well connected.
	Do not expose to flame.
	Operate as guided by Manual.

Nameplate



 Lithium Ion Battery IFpP16/122/360/[2P16S]M-10+40/90	
Model	GBLI 6531
Nominal Power	3.3kW
Nominal Voltage	51.2V
Nominal Capacity	128Ah (6.5kWh)
Rated Capacity	118Ah (6.0kWh)
Ingress Protection	IP55
Operating Ambient Temperature	-10°C - +45°C
    Made in China	



Label



WARNING

- Do not disassemble or alter the PACK to avoid heat, explosion or fire.
- Do not use the PACK beyond specified conditions. It might cause heat generation, damage, or deterioration of its performance.
- Do not throw, drop, hit, drive a nail in, stamp on the PACK. It may cause heat generation, explosion, or fire.
- In case of electrolyte leakage, keep leaked electrolyte away from contact with eyes or skin, immediately clean with water and seek help from a doctor.
- Do not put the PACK into a fire. Do not use it or leave it in a place near fire, heaters, or high temperature sources. It may cause over temperature, explosion or fire.
- Do not submerge the PACK in water, or wet the product. It may cause heat generation, explosion, or fire.
- Do not reversely connect the PACK positive (+) and negative (-) terminal.
- Do not short circuit by letting the PACK terminals (+ and -) contact a wire or any metal.
- The unit is heavy enough to cause severe injury.
- Keep out of reach of children or animals.

2.4 Precautions for PACK

- **Risks of explosion**

- Do not subject the PACK to strong impacts.
- Do not crush or puncture the PACK.
- Do not dispose of the PACK in a fire.

- **Risks of fire**

- Do not expose the PACK to temperatures in excess of 50 °C.
- Do not place the PACK near a heat source such as a fireplace.
- Do not expose the PACK to direct sunlight.
- Do not allow the battery connectors to touch conductive objects such as wires.

- **Risks of electric shock**

- Do not disassemble the PACK.
- Do not touch the PACK with wet hands.
- Do not expose the PACK to moisture or liquids.
- Keep the PACK away from children and animals.

- **Risks of damage to PACK**

- Do not allow the PACK to come in contact with liquids.
- Do not subject the PACK to high pressures.
- Do not place any objects on top of the PACK.

2.5 Emergency Responses

The PACK manufacturing takes foreseeable risk scenarios into consideration and is designed to prevent relevant hazards and dangers. However, Growatt cannot guarantee their absolute safety.

Event	Description and recommended action
Leakage	<p>If the PACK leaks electrolyte, avoid contact with the leaking liquid or gas. If someone is exposed to the leaked substance, immediately perform the actions described below.</p> <p>Inhalation: Evacuate the contaminated area, and seek medical assistance.</p> <p>Contact with eyes: Rinse eyes with flowing water for 15 minutes, and seek medical assistance.</p> <p>Contact with skin: Wash the affected area thoroughly with soap and water, and seek medical assistance.</p> <p>Ingestion: Induce vomiting, and seek medical assistance.</p>
Fire	<p>In case of fires, it is recommended to choose an ABC or carbon dioxide extinguisher. The PACK may catch fire when it is heated above 150 °C. If fire breaks out in places where the PACK is installed, perform the following countermeasures:</p> <ol style="list-style-type: none">1. Extinguish the fire before the PACK catches fire.2. If time is insufficient to put off fire immediately, move the PACK to a safe area before it catches fire.

	3. If the PACK has caught fire, do not try to extinguish the fire of PACK, but choose to evacuate people immediately.
Wet PACKs	If the PACK is wet or has been submerged in water, do not let people access it. Immediately contact your distributor for technical assistance.
Damaged PACKs	Damaged PACKs are dangerous and must be handled with the utmost care. They are not fit for use and may pose a danger to people or property. If the PACK seems to be damaged, puts it in its original container, and then returns it to your distributor.

3 Storage and Transportation

3.1 Transportation Requirement

PACK has cleared UN38.3 (Section 38.3 of the sixth Revised Edition of the Recommendations on the Transport of Dangerous Goods: Manual of Tests and Criteria) and SN/T 0370.2-2009 (Part 2: Performance Test of the Rules for the Inspection of Packaging for Exporting Dangerous Goods). The PACK is classified to class 9 dangerous goods.

- The PACK shall not be transported with other inflammable, explosive or toxic substances
- Maintain the original Package and label complete and recognizable.
- Prohibit direct exposure to sunlight, rain, condensing water caused by temperature difference, and mechanical damages.
- Prohibit to pile up more than four PACKs.
- Maintain temperature between -20 °C to 45 °C during the storage.
- Capacity degradation may occur during storage and transportation.
- Maintain relative humidity of transportation environment between 5%-95%RH under no condensing.

3.2 Storage Requirements

- Place 6.5kWh Energy Storage System according to signs on the packing case during storage. Do not put PACK upside down or sidelong.
- PACKs with deficiencies should be separated from normal PACKs by setting wall between or placing in difference fire protection zones.
- The storage environment requirements are as follows:
 - In a dry clean place with proper ventilation. Ambient temperature ranges between -30 °C to 60°C during the first seven days, and ranges between -20 °C to 45 °C within six months, relative humidity: 5%~95%RH.
 - In a place that is away from corrosive and organic substances (including gas exposure).
 - In a place free from direct exposure to sunlight and rain
 - At least two meters away from heat sources (such as a radiator)
- In a place free from exposure to intensive infrared radiation.

Overdue Storage Management

Actual storage period (month)	Average storage temperature: -20°C - +45°C
$t < 6$	The PACK does not require additional management.
$t \geq 6$	The PACK should be recharged.

Recharge procedures

- 1 Identify the PACK that needs recharging;
- 2 Refer to quick installation guidance, complete the installation and wire connection. Ensure PACK in off status during all the steps.
- 3 Set the power system as “CV=55V, CC=64A” , activate the PACK and start recharging.
- 4 Recharge until LED2 flicks.
- 5 Having completed recharge, leave circuit open for five minutes before check voltage. If voltage is not less than 52 V, the recharge succeeds.

4 Installation

4.1 Basic Installation Requirements

The PACK can be installed indoors or outdoors. Make sure the following conditions are met:

- A deviation of $-5^{\circ} \leq \theta \leq 5^{\circ}$ is allowed for both installation against wall and floor. Additionally, the distance between the bottom part of PACK and the floor should not exceed 500mm. Please refer to figure 7, Figure 8 and Figure 9 (✓ means acceptable installation and X unacceptable)

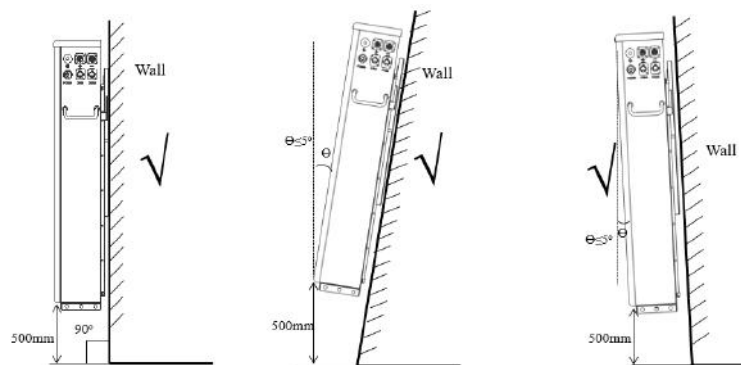

Figure 7: Acceptable wall mounted installation

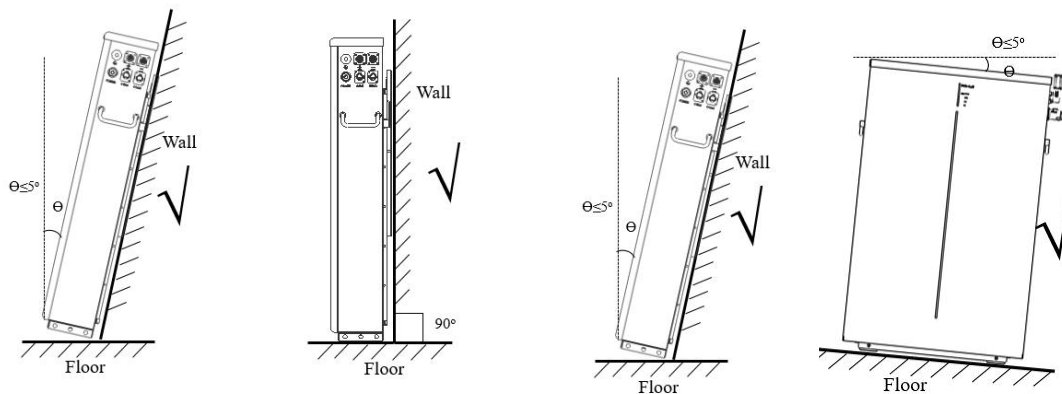

Figure 8: Acceptable floor standing installation

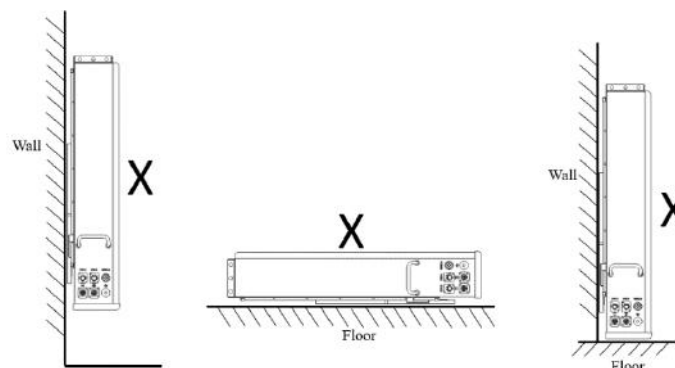

Figure 9: Prohibited installation

 **WARNING**

- Do not place the PACK upside down or keep flat as the above picture.
- Build sun & rain shade to avoid direct exposure to the sunlight and rain.

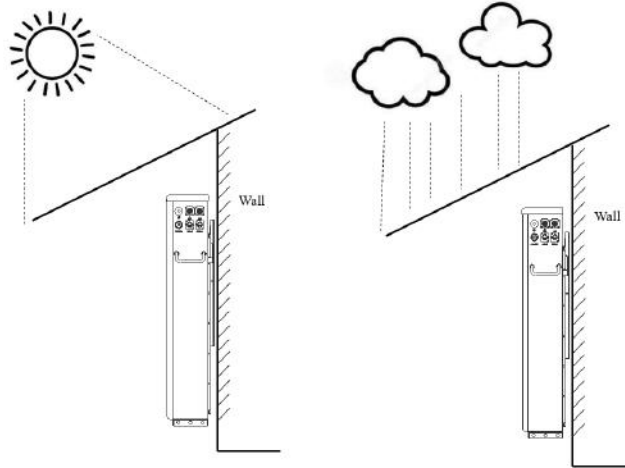

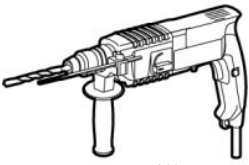
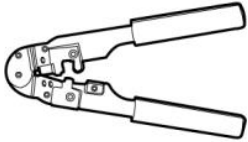
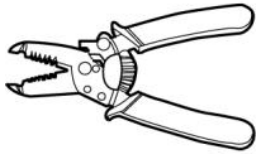

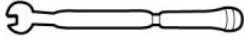

Figure 10: Sun & rain shade installation

 **WARNING**



- Do not install or use PACK nearing explosive and or inflammable substances.
- Use PACK in well-ventilated environment with temperature ranging from -10°C to 45°C ; Ensure good cooling during operation.
- The temperature and humidity is maintained at a constant level.
- There is minimal dust and dirt in the area.
- Do not install the PACK in places where flooding frequently occurs;
- Do not install the PACK to highly humid area such as bathroom;
- Do not install the PACK in a place with ammonia, corrosive vapors, acids or salts;
- Install the PACK out of the reach from children and animals;
- Ensure two PACKs in parallel connection are from the same batch, same model and same manufacturer. Do not mix old PACK with new PACK. PACKs undergone less than 300 cycles are defined as new PACKs.
- Power line and communication line connection should be done by professional installer.

4.2 Installation Required Tools

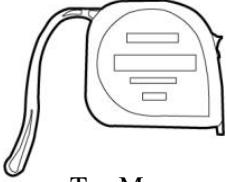
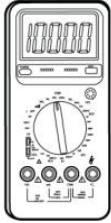
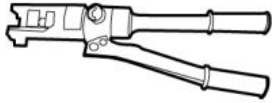
The following tools are required to install the PACK:

 <p>Drill</p>	 <p>Crimper</p>	 <p>Wire stripper</p>
 <p>Screw Driver</p>	 <p>Wrench</p>	 <p>Pencil</p>
 <p>Tap Measure</p>	 <p>Multimeter</p>	 <p>Hydraulic Pliers</p>

It is recommended to wear the following safety gear when dealing with the PACK.

 <p>Insulated Glove</p>	 <p>Safety Goggle</p>	 <p>Safety Shoes</p>
--	--	---

4.3 Installation Procedures

Pre-installation Check

Check exterior Package:

Before opening the PACK Package, check for damages like holes, crack or other traces on exterior Package. If any abnormality is detected, do not open the Package and contact your distributor.

Check and confirm the PACK is powered off before taking further steps.

Check deliverable:

Check if deliverables are complete before opening the exterior Package. If there is any part missing or damaged, please contact your distributor,

Accessory for Single PACK	
PACK	1 PCS
Line	Positive power line 1 PCS Negative power line 1 PCS Communication line 1 PCS Grounding line 1 PCS M6-OT 1 PCS M6 nut 1PCS
Fastenings	M8 expansion screw 4PCS M8*H60 anchor 4PCS Gradienter 1PCS
Manual	1 PCS
Bracket	1 PCS
Warranty Card	1 PCS

Accessory under Parallel Connection	
PACK	2PCS
Terminal	Positive terminal 2PCS Negative terminal 2PCS Communication terminal 3PCS M6-OT 2PCS M6 nut 2PCS
Fastenings	M8 expansion screw 8PCS M8*H60 anchor 8PCS Gradienter 1PCS
Manual	1 PCS
Bracket	1 PCS
Warranty Card	1 PCS

Wall Mounted Installation

Step 1: Keep the distance between bracket and wall as the below figure (320mm, 320mm, 765mm). The weight capacity of wall should exceed 70kg. At least two persons participate the installation. One person places the bracket on wall and ensure the gradienter horizontal; the other person marks four spots of screw driving. After confirming the spots to drive screws, put down the bracket.

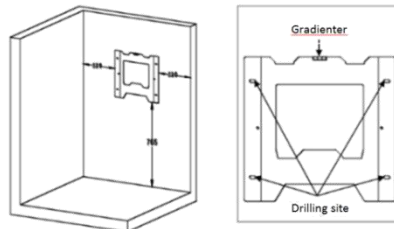

Step 2: Choose alloy drill bit with a diameter of 12mm and install it to a drill. Drill in the four spots that have been confirmed in step 1 and have at least 60 mm drilling depth. Clean the soil and drive expansion tube into the hole. One person puts the bracket on wall and minds to keep gradienter horizontal. The other person drives M8 screw through the bracket into holes.

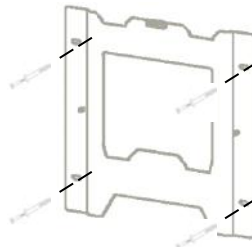

Step 3: Rotate the left hanger leftward and the right hanger rightward until they keep perpendicular to the PACK. Install PACK from the top down and lock the connection part of PACK with the support plate of bracket. Rotate the left hanger rightward until the notch locks limiting pin, rotate the right hanger leftward until the notch locks limiting pin too.

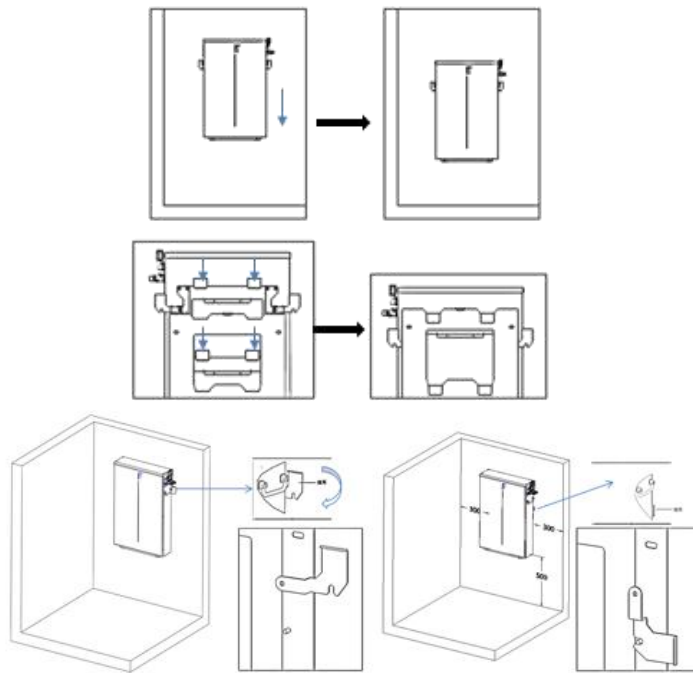

CAUTION

In order to ensure a stable connection between PACK and bracket, please visually check if the two upper joints are fixed. Try to move the lower part of PACK away from wall. The connection is proved qualified if the PACK cannot be moved at all; otherwise, please connect the Pack and bracket again until confirming a fixed connection.

Step 4: Having confirmed fixed installation of PACK, plug the connected power lines into PACK terminals (orange positive terminal and black negative terminal). Plug the well-connected CAN communication line into the communication ports of PCS and PACK. Please refer to Section 4.4 and Section 4.5 for wire connection details.

Floor Standing Installation

Step 1: Place PACK in the to-be installed area. Rotate the left hanger leftward and the right hanger rightward until they are perpendicular the the PACK. Keep the distance between wall and PACK as shown in the below figure (300mm, 300mm). Use pencil to mark where the notches of two hangers are and confirm the drilling spots. Move PACK away.

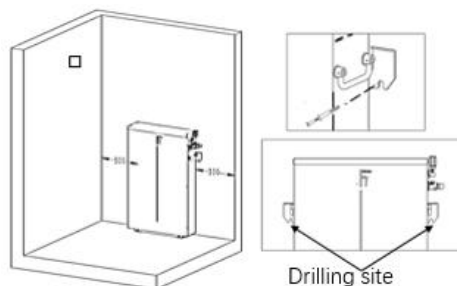

Step 2: Choose an alloy drill bit with a diameter of 12mm and install it in the drill. Drill two holes in the spots that have been confirmed in step 1. Keep the drilling depth the same as that of bolt. Clean hole soil and drive expansion tube into hole. Move PACK back to the place confirmed in step 1. Drive M8 screw through notch of hanger into wall.

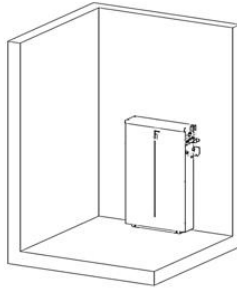

Step 3: Check and confirm PACK is fixed to wall. Plug the well-connected power lines into terminals of PACK (orange positive terminal and black negative terminal). Plug the well-connected CAN communication wires into communication ports of PACK and PCS. Please refer to Section 4.4 and Section 4.5 for wire connection details.

4.4 Electrical Connection

Terminal Definition:

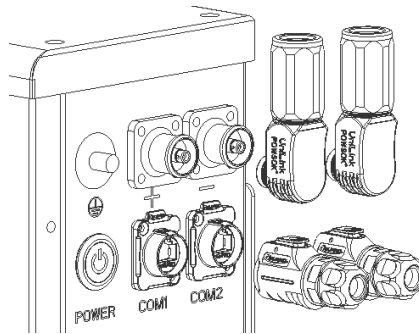

Figure 11: Terminals on PACK

Serial No.	Item	Quantity	Specifications	Symbol
1	Positive terminal	1	IP67 –Orange connector	+
2	Negative terminal	1	IP67 –Black connector	-
3	Grounding terminal	1	M6 Screw	⊕
4	POWER button	1	IP55—Button to turn on or off the PACK	POWER
5	Communication Port	2	IP67 RJ45 water proof connector	COM1 , COM2

Communication interface definition:

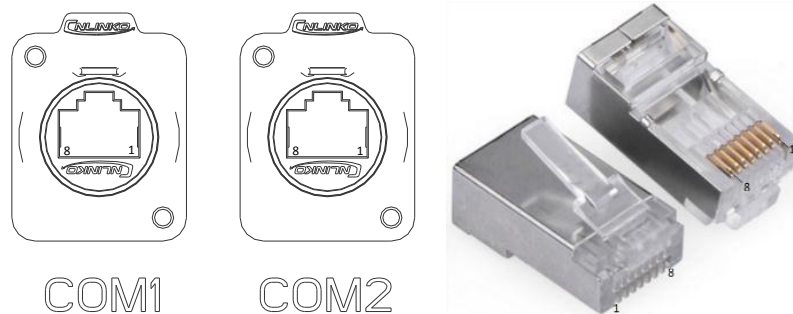

Figure 12: RJ45 communication port

RS485&CAN crystal plug definition:



Item	Crystal head picture	Serial no.	Definition
COM1		1	RS485B
		2	RS485A
		3	GND2
		4	CANH
		5	CAHL
		6	GND2
		7	WAKE-
		8	WAKE+
COM2		1	RS485B
		2	RS485A
		3	GND2
		4	CANH
		5	CAHL
		6	GND2
		7	WAKE-
		8	WAKE+

Figure 13: crystal head pin definition

Step 1 wear ESD wrist strap and gloves, safety gloves and goggles.

Step 2 connect main power lines.

Sub-step	Picture	Description
1		Strip cable sheaths at both ends for 15 ± 0.5 mm, with orange positive terminal and black negative terminal.
2		Insert the copper all into joint sleeve.
3		Press the wire and terminal with a hydraulic clamp.
4		Tighten up sealing, sealing nut and joint sleeve.

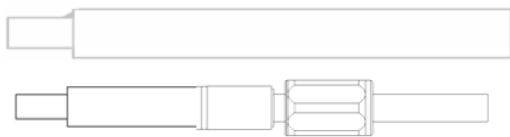
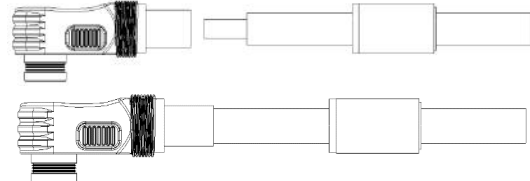
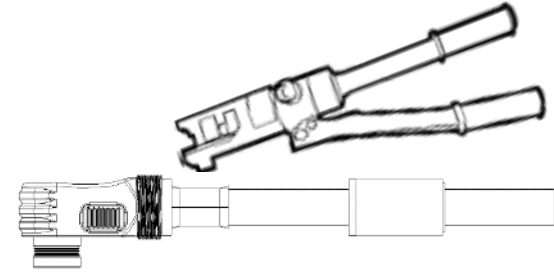
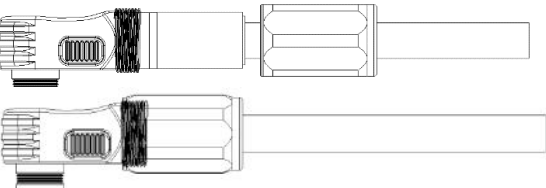
Step 3 connect communication lines.

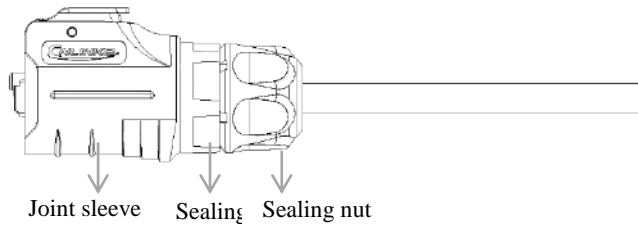
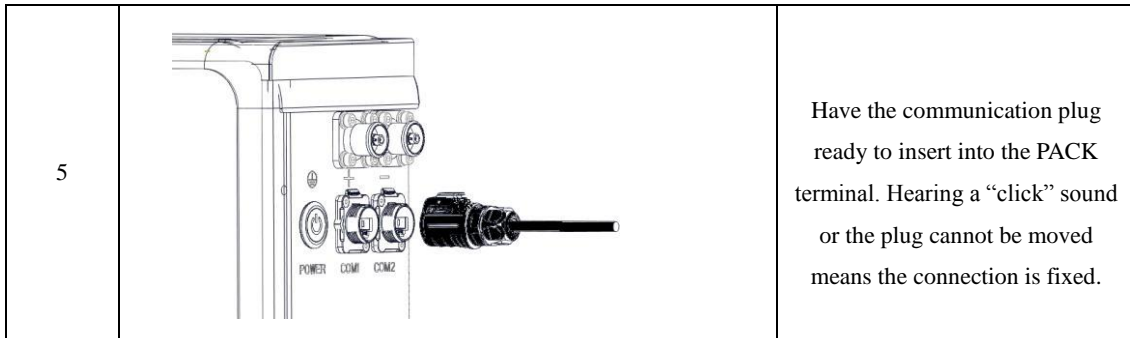
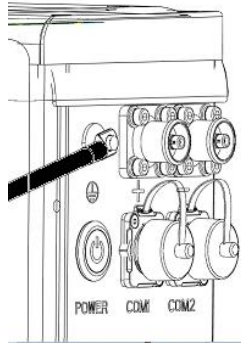

Figure 14: Communication Terminal

Sub-step	Picture	Description
1		<p>Insert sealing and sealing nut along the wire.</p>
2		<p>Strip cable sheaths at both ends for 15 ± 0.5mm. Communication wire adopts standard 8-core cable. As for CAN cable, cut six small lines and insert two remaining lines of both ends into pin 4 and pin 5 of two crystal plugs. Similarly for RS484 cable, cut six small lines and insert the two remaining lines into pin 1 and pin 2 of crystal plugs. Keep the line color and pin consistent.</p>
3		<p>Crimp the crystal plug with wire crimper.</p>
4		<p>Connect crystal plug with joint sleeve, and tighten up sealing nut, sealing and joint sleeve.</p>



Step 4: Fasten ground terminal and ground line with M6 screw.



Step 5: Insert positive and negative power lines, and communication line.

Measure PACK voltage with a multi-meter and ensure the voltage output is 0V. Plug one ends of the power lines that have been connected in step 2 of Section 4.4 into DC breaker, and plug the other ends into the terminals on PACK (orange positive terminal and black negative terminal). Plug the CAN communication wire that has been connected in Section 4.4 step 3 into the RJ45 terminal on PACK (Both COM1 and COM2 works), and plug the other end of CAN communication wire into communication port of PCS.

4.5 Installation Steps under Parallel Connection

Parameter configuration under parallel connection	
Item	Parameter
PACK Number	2
Rated Power	5kW
Communication between PACKs	RS485
PACK voltage difference limit	$\Delta V_{\text{pack}} \leq 1V$
Distance between PACKs	$30\text{cm} \leq D \leq 50\text{cm}$

Step 1: Install PACK.

Power on two PACKs in condition of no load, measure the voltages with a multi-meter and confirm voltage difference less than 1V. After that, power off two PACKs and install PACKs according to the procedures specified in Section 4.3. For either wall-mounted or floor standing installation, the distance between two PACKs should range between $30\text{cm} \leq W \leq 50\text{cm}$.



WARNING

If the voltage difference is measured more than 1V, the difference shall be adjusted to be less than 1V either by charging the PACK with lower voltage or discharging the PACK with higher voltage before conducting the parallel connected installation.

Step 2: Insert main power lines

Connect power lines of both PACKs based on the second step of Section 4.4. Plug one ends of positive and negative terminals into direct current breaker according to Figure 2 *electrical diagram of parallel connection*. Measure the positive and negative cathodes of both PACKs with a multi-meter, and ensure the voltage output under off mode is 0V. After that, plug the other ends of power lines into terminals on two PACKs (orange positive terminal and black negative terminal).

Step 3: Insert communication line

Connect RS485 and CAN wires based on the third step of Section 4.4. Connect two PACKs with the RS485 wire, and connect PACK and PCS with the CAN wire according to Figure 2 *Electrical Diagram of Parallel Connection*. Specifically, Plug two terminals of RS485 wire into two communication ports of PACKs, plug one end of CAN wire into the left port of any PACK, and plug the other end into PCS communication port.



WARNING

RS485 wire only applies to the communication between two PACKs in parallel connection, and CAN wire only applies to communication between one PACK and PCS.

5 Power on and Power off



WARNING

- There are many technical contents involved in the electrification process of the equipment, and the electrification personnel must go through technical training and obtain certificates that are in compliance with local law and regulations. Please ensure technicians have obtained training certificate before operation.
- Please stand on dry insulating objects and do not wear metal objects such as watches and necklaces during operation. Insulated tools should be used.
- Do not contact with two charged positions with potential difference.
- If other people are not allowed to operate, the prohibition sign should be hung on the distribution equipment: "No closing, someone operating."
- In the process of power on, if any abnormalities are detected, immediately power off the PACK. After causes are identified, proceed again.
- Make sure that the inverter is turned off while checking the PACK.

5.1 Power-on Commissioning

Power on single PACK by pressing POWER button		
Serial	Procedures	Acceptation criteria
1	Close the breaker that is connected with positive and negative power lines.	Breaker in ON status
2	Press POWER button for two seconds and observe the LED indication on panel.	1. If both RUN and SOC lights turn on normal, PACK powers on successfully. 2. If ALM light turns red, there is a failure and should fix before power on again.
Power on single PACK by PCS		
1	Close the breaker that is connected with positive and negative power lines.	Breaker in ON status
2	Supply PCS power with PV or mains supply.	1. PCS in ON status. 2. HMI of PCS indicates normal PV or mains supply input.
3	PCS main circuit voltage signal activates PACK.	1. If RUN light and SOC lights on PACK indicate normal, and PACK powers on successfully. 2. If the ALM light of PACK turns red, the indication shows a failure of parallel connection. The failure shall be fixed before power on again.

Power on parallel connected PACKs by pressing POWER button		
Serial	Procedures	Acceptation criteria
1	Close the breaker that is connected with positive and negative power lines.	Breaker in ON status
2	Press POWER button for two seconds within 30 seconds and observe the LED indication on panel.	1. If RUN and SOC lights on both PACKs turn on normal, and the RUN lights on both PACKs flicker for five time, two PACKs power on successfully and communication between PACKs works. 2. If ALM light of one or both PACKs turns red, there is a parallel failure and should be fixed before power on again.
Power on parallel connected PACKs by PCS		
1	Close the breaker that is connected with positive and negative power lines.	Breaker in ON status
2	Supply PCS power with PV or mains supply.	1. PCS in ON status. 2. HMI of PCS indicates normal PV or mains supply input.
3	PCS main circuit voltage signal activates PACK.	1. If RUN lights and SOC lights on both PACKs indicate normal, and RUN lights on both PACKs flicker for five times, two PACKs power on successfully and communication between PACKs work. 2. If the ALM light of one PACK or both PACKs turn red, there is a parallel connection failure and should fix before power on again.

5.2 Power off PACK

Power off methods

- Turn off the inverter. After communication drops for 60 minutes, PACK powers off and five LED lights flicker for three times.
- Press the POWER button for two seconds to turn off PACK and five LED lights will flicker for three times.

6.1 Preparation

- Prepare tools like safety gloves, cross head driver and socket wrench.
- Turn off and turn on new PACK.
 1. Press POWER button for two seconds and PACK enters power-off mode.
 2. Press POWER button for two seconds when PACK is in off mode, PACK enters power on mode.

When replacing PACK in field site, open air switch at first if there is air switch. Before installing the new PACK, press its POWER button for two seconds and have the PACK entering power-off mode. Follow the installation and wire connection procedures specified above. Ensure wires are properly connected before close air switch. After that, close air switch. Press POWER button of new PACK for two seconds to check if the system works normal.

6.2 PACK Replacement

- Wear safety gloves
- Open air switch, press POWER button for two seconds, and five LED lights flicker will for three times. After that, PACK is powered off.
- Unplug main power line terminals and CAN communication terminal from main circuit.
- Wall-mounting PACK: rotate both hangers upward, two persons lift up the PACK off bracket.
- Floor-standing PACK: unscrew expansion screws with a cross screwdriver, rotate hangers upward and move PACK.
- Two persons move PACK via handlers into Package and transport PACK to the designated repair site.
- Install new PACK based on procedure specified in Section 4.

6.3 Software Upgrade

Step 1: Install software

1. Choose file “BMS Installation package.zip” and decompress.
2. Enter “BMS Installation package \Volume”, double click “setup.exe” and run.

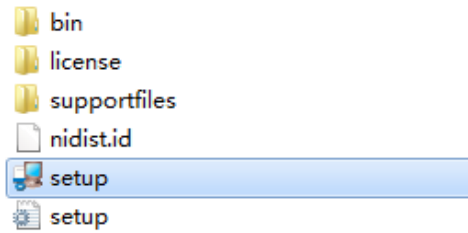

3. Execute the default configuration until complete installation.

Step 2: Connect computer and the COM1 or COM2 of PACK with CANalyst-II.

Step 3: Upgrade

1. Choose “Upgrade” as shown in the below figure.



2. Configure CAN communication device by choosing “CANalyst-II”, setting “500Kbps” baud rate and keeping other default parameters. After that, click “OK”.

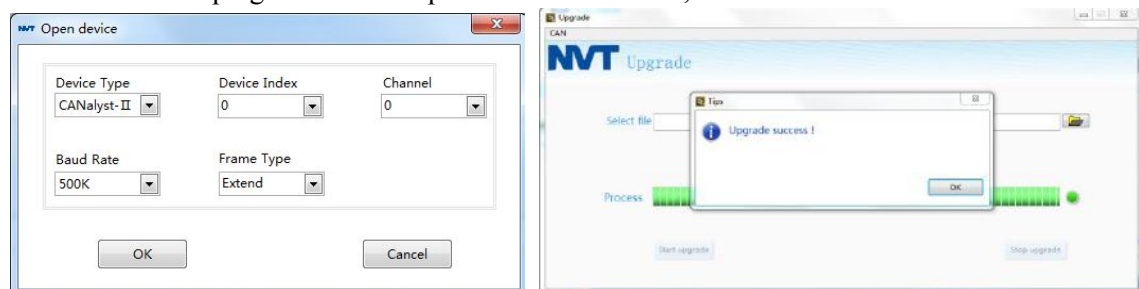

3. Choose target upgrade file.

4. Click “start to upgrade” and wait.

5. Progress shows current upgrade status. With 100% progress, a window pops out to indicate upgrade success.

6.4 System Failure Information List and Troubleshooting Suggestions

Error Indication	Error description	Error cause	Suggested actions
ALM			
★ (ALM Light Flickers)	0%-12%	Low PACK capacity	1. There is no safety threat and can continue to discharge PACK.
	Two/three level discharge under voltage protection	Single cell voltage below the threshold for under-voltage protection.	There is over discharge risk. User should stop discharging and arrange recharge.
	Three level charge over	Single cell voltage exceeding	1. There is no safety threat;

●(ALM Light on)	voltage protection	threshold for protection threshold.	2. User should stop charging. Idle PACK and it will turn to normal status.
	Three level charge over current protection	Charging current exceeding protection threshold.	1. There is safety risk and user should stop using PACK. 2. User should contact installer to repair PCS.
	three level discharge over current protection	Discharging current exceeding protection threshold.	
	three level low temperature charge protection	Cell surface temperature below PACK temperature low limit	There is no safety threat and user should stop using battery.
	Three level low temperature discharge protection		
	Three level high temperature charge protection	Cell surface temperature exceeding PACK temperature up limit.	There is safety risk and user should stop using battery. User should contact installer to repair battery.
	Three level high temperature discharge protection		
	Three level protection against over voltage difference among cells	Cell voltage difference exceeding protection threshold.	1. There is no safety risk. 2. User should contact installer to repair battery.
	Charge short circuit protection	External short circuit of PACK	There is safety risk and user should stop using battery. User should contact installer to repair PCS and battery.
	discharge short circuit protection		
	Parallel connection failure protection	Communication failure between two parallel connected PACK	1. Check RS485 connection between two batteries, CAN connection between Battery and PCS; 2. Measure voltages of two batteries and ensure the difference less than 1V; 3. Check if two batteries power on within 30s.
	Relay1 failure	Relay drive failure or relay failure	There is safety risk and user should stop using battery. User should contact installer to repair battery.
	Relay2 failure		
	Pre-charge relay failure		

	Voltage sampling front-end failure	BMS internal communication failure	
	Temperature sampling failure	BMS temperature sampling circuit failure	
	Current sampling failure	BMS current sampling failure	
	failure of over voltage difference among cells ($\Delta > 1V$)	Over voltage difference among cells	
	Communication failure	Communication loss between PCS and PACK.	<ol style="list-style-type: none"> 1. There is no safety threat and user should stop using battery. 2. Check if PCS and battery communication terminal is well connected. 3. If PCS and PACK cannot communicate when the communication wire is confirmed well connected, user should contact installer to repair battery.
	Current limitation failure	Current limitation failure, ALM light maintains on	<p>There is safety risk and user should stop using battery.</p> <p>User should contact installer to repair battery.</p>

7 Technical Specifications

Functional parameters of 6.5kWh Energy Storage System are as shown below:

No.	Items	Specifications
1	Nominal Capacity/Energy	128Ah/6.5kWh
	Rated/Usable Capacity/Energy	118Ah/6.0kWh
2	Typical Voltage	51.2 V
	Operating Voltage	48~57.6V
3	Standard charging current (25°C)	64A
	Max. discharging current (25°C)	96A
4	Rated discharging power	3.3Kw
	Max. discharging power	4.2kW
	Peak discharging power	5kW/3S
5	Operative temperature range	-10°C~45°C
	Recommended operating temperature	0°C~30°C
6	Storage conditions	Temperature: -20 °C ~ + 45 °C Humidity: 5%~95%RH Within 6 month after initial charge
7	Room temperature cycle life(25 °C)	≥6000cycle/60%EOL
8	Cooling	Natural cooling
9	Dimension	W475*D133*H745 mm
10	Weight	58kg±1Kg
11	Installation	Wall-mounted installation/floor standing installation
12	Ingress protection	IP55
13	Cell safety certification	IEC62619/UL1973
14	PACK safety certification	IEC62619/CE/RCM/UL1973/CEC
15	UN transportation test standard	UN38.3+PI965 (Sea)
16	Communication port	CAN2.0B*1CH; RS485*1CH;
17	Parallel connection	Two PACKs

Appendix I

LED indication Control Mechanism

LED light definition							
Status	SOC	SOC indication				RUN/ALM (green and red lights)	Remark
		LED1	LED2	LED3	LED4	LED5	
charging	0%-25%	■(T=1s)				●	RUN light on and SOC lights flicker
	26%-50%	■(T=2s)	■(T=1s)			●	
	51%-75%	■(T=3s)	■(T=2s)	■(T=1s)		●	
	76%-99%	■(T=4s)	■(T=3s)	■(T=2s)	■(T=1s)	●	
	100%	●	●	●	●	●	
Discharging	100%-81%	●	●	●	●	●	
	80%-61%	●	●	●		●	
	60%-41%	●	●			●	
	40%-16%	●				●	
	15%-0%	●				★	LED1 flickers
Idle	0%-15%	●				★	LED1 flickers
	16%-40%	●				●	
	41%-60%	●	●			●	
	61%-80%	●	●	●		●	
	81%-100%	●	●	●	●	●	
Parallel connection	Parallel connection succeeds	SOC indicates current remaining capacity				★	RUN light flickers for five times when parallel connection succeeds.
Protection	Level two/three discharge under-voltage protection	SOC light turns off during protection				●	ALM light remains on under level three discharge under-voltage protection
	Level three charge over-voltage protection					●	ALM light remains on under level three charge over-voltage protection
	Level three charge overcurrent protection					●	ALM light remains on under level three charge over-current protection
	Level three discharge overcurrent protection					●	ALM light remains on under level three discharge over-current protection
	Level three charge under-temperature protection					●	ALM light remains on under level three charge under-temperature protection
	Level three discharge under-temperature protection					●	ALM light remains on under level three discharge under-temperature protection
	Level three charge high-temperature protection					●	ALM light remains on under level three charge high-temperature protection
	Level three discharge high-temperature protection					●	ALM light remains on under level three discharge high-temperature protection
	Level three					●	ALM light remains on when protection

	protection against over voltage difference of cells			initiates against over voltage difference of cells
	charge short circuit protection		•	ALM light remains on under charging short circuit protection
	discharge short circuit protection		•	ALM light remains on under discharging short circuit protection
	Parallel connection failure		•	ALM light remains on with parallel connection failure
Failure	Relay1 failure	SOC light turns off with failure	•	ALM light remains on with Repay1 failure
	Relay2 failure		•	ALM light remains on with Repay2 failure
	Pre-charge Relay failure		•	ALM light remains on with pre-charge Repay failure
	voltage sampling chip failure		•	ALM light remains on with failure in the voltage sampling chip
	Temperature sampling failure		•	ALM light remains on with temperature sampling failure
	Current sampling failure		•	ALM light remains on with current sampling failure
	Over voltage difference ($\Delta > 1V$) of cells		•	ALM light remains on with over voltage difference of cells
	Communication failure		•	ALM light remains on with communication failure
	Current limit failure		•	ALM light remains on with current limit failure
	Switch on indication		1.Press Power button for 2s; 2. LED1~LED5 turns on one by one.	
Switch off indication	1. Press Power button for 2S; 2. LED1~LED5 flickers by 2HZ for three times before all turning off.			

T: +86 0755 2747 1942

E: service@ginverter.com

W: www.ginverter.com

Address: No. 28 Guangming Road, Shiyan Street, Bao'an District, Shenzhen, P.R. China