



NOTICE

- Ensure to read the Guidance before installation in order to understand product information and safety cautions;
- Operators should be well trained technicians and fully understand the whole photovoltaic system, grid network, working principle and national regional standards;
- Installers must use insulating tools and wear safety equipment;
- Device damages caused by failure to comply with storage, transportation, installation and use requirements specified in Guidance are not covered by Warranty.
- Build sun& rain shade to avoid direct exposure to the sunlight and rain.

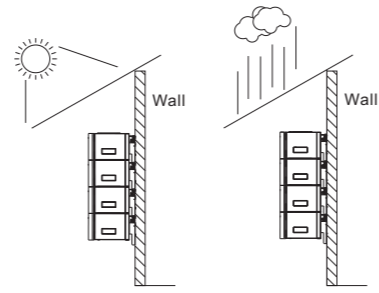

Fig 1 sun& rain shade for batteries

1. Checking

1. Open the package and take out all the accessories.
2. Check the quantity of all parts inside according to the package list.

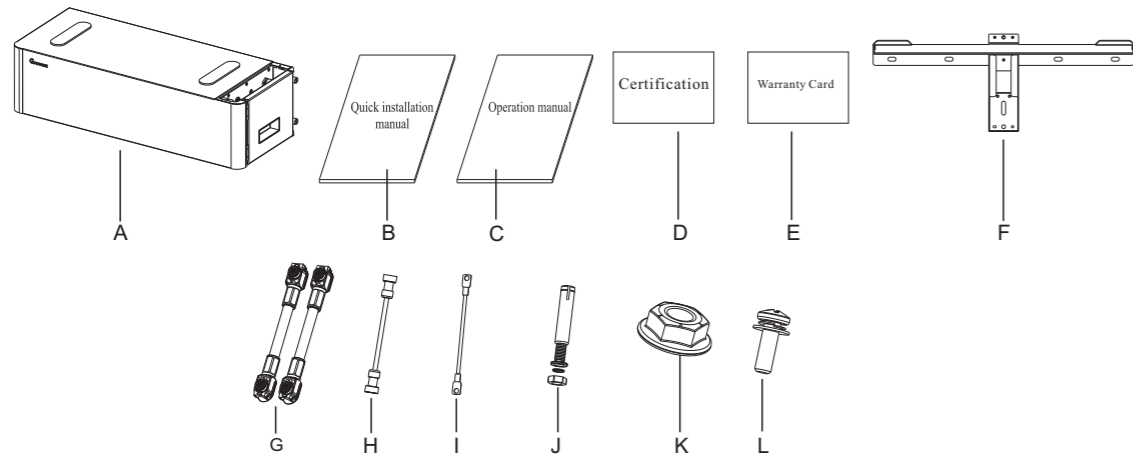

Fig 2 ARK 2.5L-A1 Drawings of parts

Item	Description	Qty.	Item	Description	Qty.
A	ARK 2.5L-A1	1	F	Positive and negative parallel power line(Two wires)	1
B	Quick installation Manual	1	H	Parallel communication line	1
C	Operation Manual	1	I	Ground wire	1
D	Certification	1	J	M6 explosive screw	2
E	Warranty Card	1	K	M6 flange nut	1
F	Wall Hangers	1	L	M4x10 Combination screw	2

3. Check the accessories

- There are three types of accessory boxes, one for the wires that connect the PCS ,one for connecting two stacks of battery systems and the other for installation base. Accessories list are shown as blow.
- Standard Wall-Mounted Installation: ARK 2.5L-A1+Wires connect to PCS.
- Standard floor installation: ARK 2.5L-A1+Wires connect to PCS+ Installation base.
- Wall-Mounted Battery system stacked in two line: ARK 2.5L-A1+Wires connect to PCS+ Wires connecting two stacks of battery systems.
- Floor installation battery system stacked in two line: ARK 2.5L-A1+Wires connect to PCS+ Wires connecting two stacks of battery systems+ Installation base.

Wires connect to PCS			Wires connecting two stacks of battery systems		
Item	Description	Qty.	Item	Description	Qty.
A	Positive and negative power line to PCS(Two wires)	1	A	Positive and negative power line for two stacks of battery systems(Two wires)	1
B	Communication line to PCS	1	B	Communication line for two stacks of battery systems	1
C	ARK 2.5L-A1 Wire plate	1	Installation base		
D	M4*8 countersunk screw	1	Item	Description	Qty.
E	Silicone coil	1	A	Base	1
F	M6 external hexagon torque wrench	1			

2. Installation Process (Wall-Mounted without base)

2.1 Installation Location Requirements

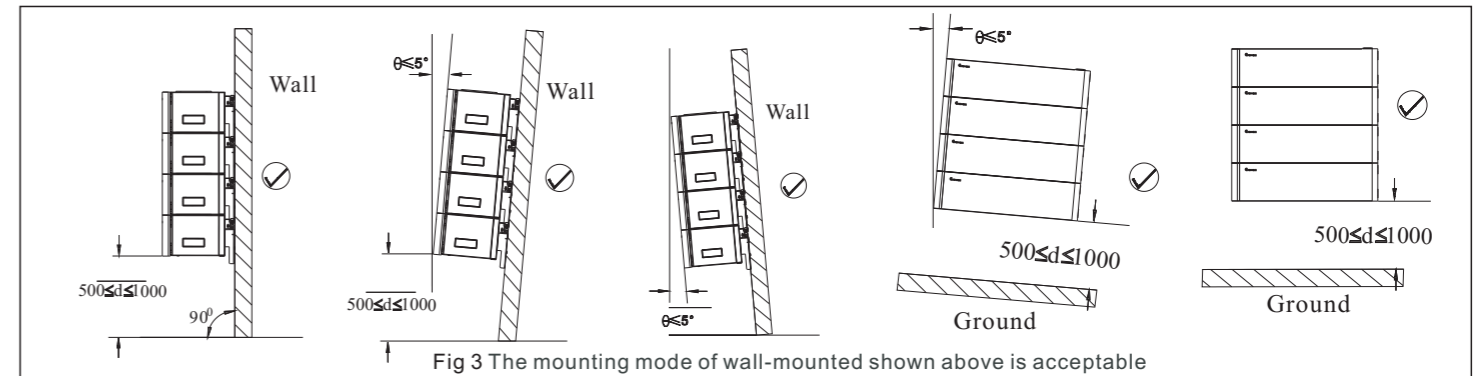

Note:

Single/multiple battery are installed on the wall and the installation angle required above.
The number of wall-mount installations should not exceed four.

2.2. Installation procedure

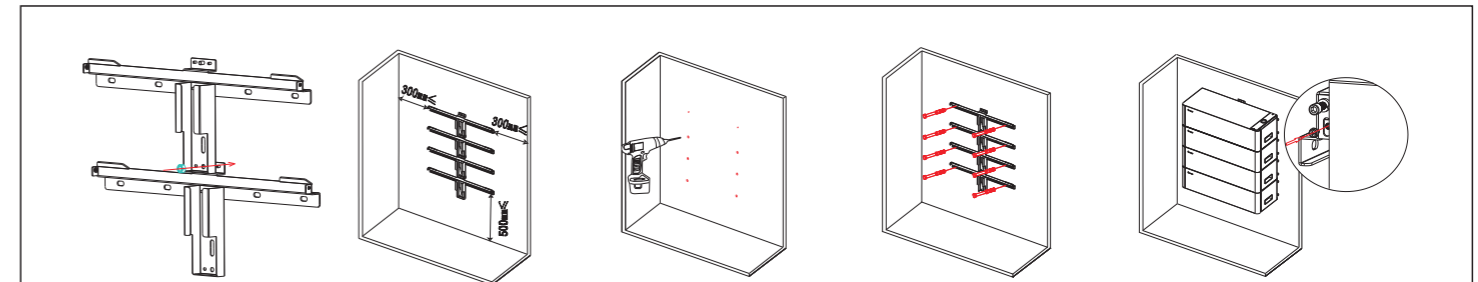

Fig 4 Multiple ARK 2.5L-A1 installation process

1. Please make sure that the weight capacity of wall should exceed 150kg.
2. Assemble the wall hangers together with M6 flange nut.
3. Place the wall hangers on the wall and mark the holes that need to be punched.
4. Remove the wall hangings and drill a hole at the marked point with a depth of 55mm at the mark with a drill of $\phi 8$,
5. Place the wall hangers and expand the bolt with a hammer into the hole in the wall , install the nut(including elastic flat pad)and tighten the nut with a wrench.
6. Hang the ARK 2.5L-A1 on the wall hangers.
7. Adjust the battery level with M6 external hexagon torque wrench.
8. Install the safety screws (M4x10 Combination screw) on both sides of all modules.

3. Floor installation with base

3.1 Installation Location Requirements

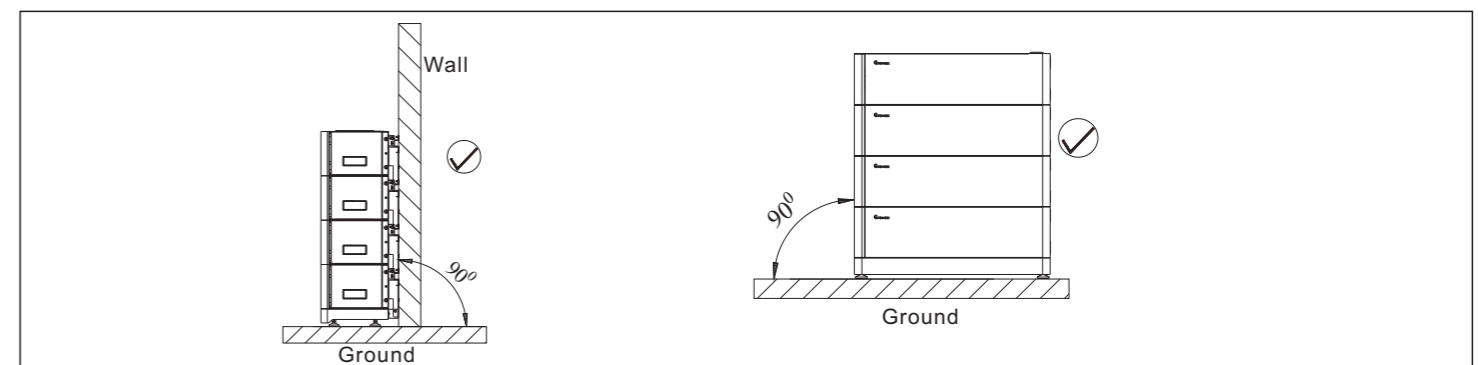

Fig 5 The mounting mode of the base shown above is acceptable

1. If the battery is mounted with a base, The mounting mode of the base shown above is acceptable.
2. Wall hangers with fewer screws are required as well, which is shown in figure6.
3. If more than 4 batteries are used, base mounting is recommended.
4. For floor installation, we recommend that the number of the stacked battery modules is no higher than six.

3.2. Installation procedure

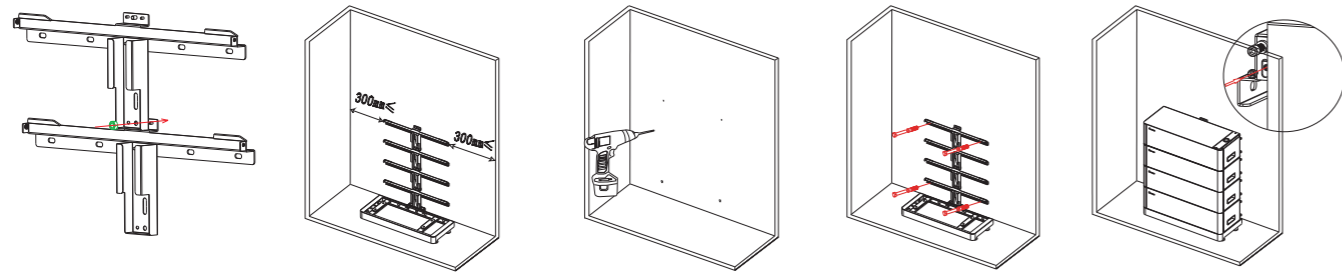

Fig 6 Multiple ARK2.5L-A1 with base installation process

1. Assemble the wall hangers together with M6 flange nut.
2. Place the mounting base where you want the battery to be mounted.
3. Place the wall hangers on the wall and match the base.
4. Mark the holes that need to be punched; Noted that only two ends of the top wall hanger and the bottom wall hanger need to be marked.
5. Remove the wall hangings and the base and drill a hole with a depth of 55mm at the mark with a drill of $\phi 8$.
6. Expand the bolt with a hammer into the hole in the wall, place the wall hangers and based, install the nut (including elastic flat pad) and tighten the nut with a wrench.
7. Hang the ARK2.5L-A1 on the wall hangers.
8. Adjust the battery level with M6 external hexagon torque wrench.
9. Install the safety screws (M4x10 Combination screw) on both sides of top module.

4. Electrical wiring

Note:
The battery is not allowed to be installed in the running state, and all the RUN lights of battery modules should be off before installation.
To ensure system security, do not forget to install ground wire.
For the power lines connected to PCS, the positive power line is drawn from the top battery module, and the negative power line is drawn from the bottom battery module.
The switch connect PCS to ARK 2.5L-A1, we recommend the use of molded case circuit breaker with rated working voltage greater than 500V and rated working current greater than 125A.

Fig 8 Schematic diagram of power and communication wiring harness connections

1. Before connecting the power wiring harness, please pay attention to the positive and negative terminals, the red terminals are connected to the positive terminals and the black terminals to the negative terminals.
2. The PCS communication terminal is used to communicate to the PCS. Link-in terminals are used for signal inlet of multiple parallel battery modules. Link-out terminals are used for signal output of multiple parallel battery modules.

Fig 9: parallel connection stacked in two line

When stacked in two lines, you need to buy the accessory of wires connecting two stacks of battery systems. The connection mode is shown in the fig 9.

4.1. Power line connection

Fig 10 Connect power terminals

Fig 11 Disconnect power terminals

Press the position indicated in the figure above before disconnecting the power terminal.

4.2. Communication line connection

Fig 12 Connect Communication terminal

Fig 13 Disconnect Communication terminal

The parallel communication connection is from the LINK-OUT port of the top module to the LINK-IN port of the next module shown in Fig 7.

5. Key operation

5.1 Power button

Mark	Situation	Touch	Definition
	When the system is off	Press($\leq 2S$)	No reaction
		Press($\geq 2S$)	Power on
	When the system is on	Press once	Shut down

Note: When multiple battery modules are used in parallel connection, you only need to press one key of any module to start the system, and also press one of the keys to shut down the battery system.

6. Service and contact

Shenzhen Growatt New Energy Co., Ltd.
2F and 3F, Building 4, Jiayu Company Industrial Park, Xibianling, Shangyu Village, Shiyan Street, Bao'an District, Shenzhen

T +86 0755 2747 1942
E service@ginverter.com
W www.ginverter.com



Download Manual



Growatt New Energy