

Engineering Recommendation G100 Declaration

SolaX Power Network Technology (Zhe jiang) Co. , Ltd.
hereby confirms that X1-Retro Fit Series inverter(the model shown as below) complies with the power meter (&CTs) recommended by SOLAX, Engineering Recommendation G100 Issue 1 2016, Technical Guidance for Customer Export Limiting Schemes, when installed in accordance with this Engineering G100 Declaration.

This Declaration should be read in conjunction with the inverter user manuals and meter quick installation guide.

X1-Fit-3.7E X1-Fit-4.6E X1-Fit-5.0E
X1-Fit-3.7I X1-Fit-4.6I X1-Fit-5.0I
X1-Fit-3.7C X1-Fit-4.6C X1-Fit-5.0C

1. Introduction

Engineering Recommendation G100: Technical Guidance for Customer Export Limiting Schemes, published by the ENA, “defines the technical design requirements for Export Limitation Schemes which limit the net site export to below an agreed maximum and are installed on the Customer’s side of the Connection Point”.

This document describes how a SOLAX X1-Retro Fit Series inverter installation performs relative to key G100 requirements.

2. Description of Operation

G100 Requirement:

A description of the scheme, its settings, and a single line diagram should be permanently displayed on site.

SOLAX X1-Retro Fit Series inverter can be set the export limiting power on the inverter LCD display based on customer or local rules requirements. SOLAX named this function “export control” on LCD display and it can be can be set from 0-6000W. This function means customer should install a meter(power monitoring unit) to monitor energy exported to or imported from the grid.

Note: Please see section 7 of specific LCD display operation.

After setting the export limit power, the system switches between 3 operational states:

- Charging: X1-Retro fit charges when site-export is detected, to minimise electricity exported to the grid (loads less than solar generation)
- Discharging: X1-Retro fit discharges when site-import is detected, to minimise electricity import from the grid (loads greater than solar generation)
- Idle: No charge or discharge (battery full/flat or no solar/load)

A fundamental principle of this operation is that energy stored in the battery is only released to run loads within the building - at no time is the system attempting to export battery energy to the grid. This control is achieved by:

Meter(Power Monitoring Unit)

- The “Meter” - a power meter (& CTs) recommended by SOLAX.
- Measures power flowing in/out of the home and sends this data to inverter.
- Connected to the inverter via a communication cable

3. System schematic

An X1-Retro Fit Series inverter installation is shown as below:

- **X1-Retro fit:** controls the AC output power according to the data from meter.
- **SOLAX Meter:** Collects power data and feeds this data to the Inverter.

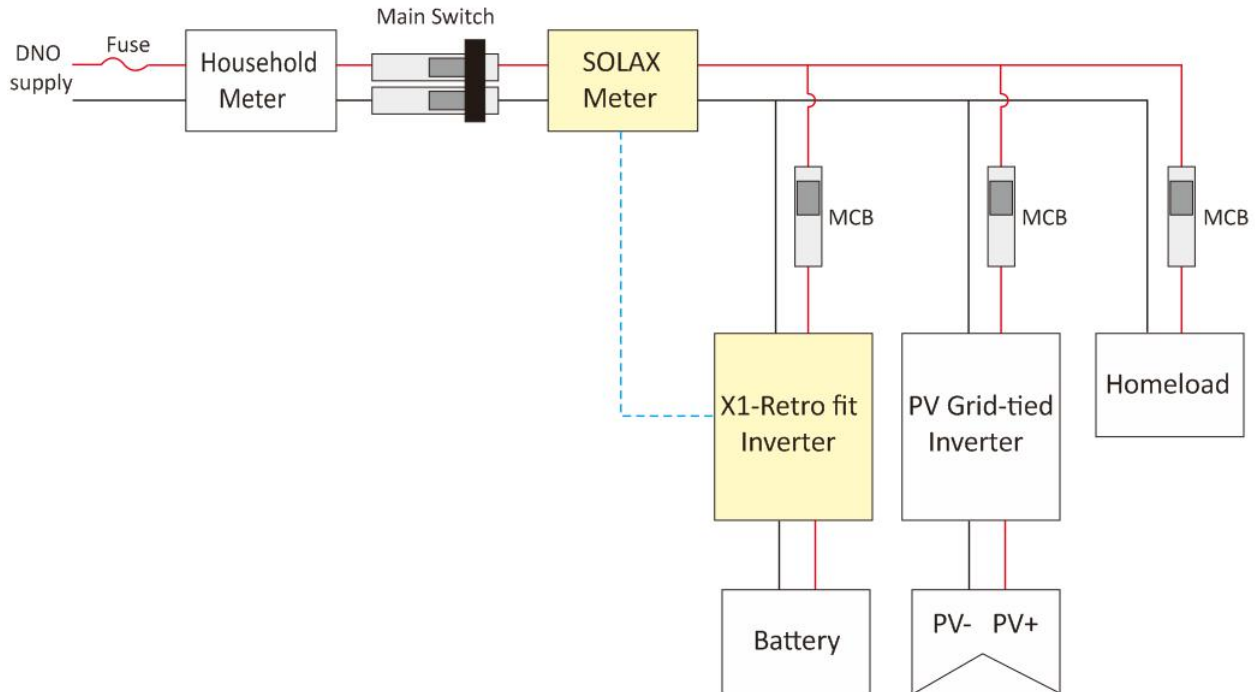

4. Component interconnection | Fail-safe operation

G100 requirement:

Where discrete units are used they should preferably be interconnected using metallic or fibre optic cables. Alternatively the units may be interconnected using secure radio links but where this is the case these links should be licensed (by OFCOM) and have a planned availability of 99.9% or higher. Irrespective of the media used for interconnecting between the discrete units, if the communication path fails the generation output should be reduced to a nominal value stipulated by the DNO within a set response time to prevent the Agreed Export Capacity from being exceeded.

As shown in the diagram below, communication between all parts of the system can be wired.

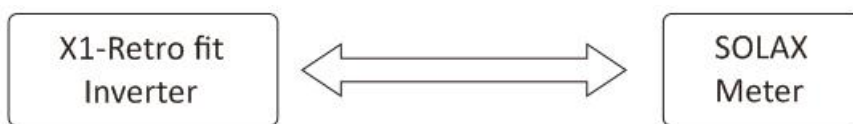

Unplugging or otherwise interrupting any of these wired connections, results in the system turning off. The system reaction speed under these conditions is less than 5s.

System fail-safe tests				
No.	Test	System response	Time	Pass?
1	Remove Power to meter	Loss of meter data detected System switches off	<5s	Yes
2	Unplug comms cable between Inverter and Meter	Loss of meter data detected System switches off	<5s	Yes
See Annex A for test results				

5. Response time

G100 requirement

The ELS must detect an excursion and reduce the export to the Agreed Export Capacity or less within 5 seconds.

Under normal operating conditions, X1-Retro Fit Series response time is less than 5s

Under loss of communications, or loss of power to Meter, response time is less than 5s

6. Password protection

G100 requirement:

Once installed and commissioned, the scheme settings should not be capable of being readily altered by the Customer and should only be changed with the written agreement of the DNO.

All X1-Retro Fit Series inverter export limit settings are password protected.

7. LCD display operation

Customer should set “export control” function on the LCD display. “Export Control” setting can be found according to path below.

- Menu — Setting — Advanced — On-grid — Export Control.

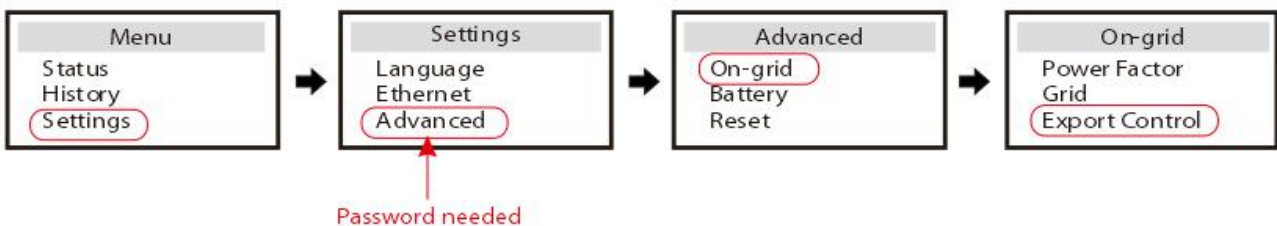

- This value can be set from 0-6000W.
For example, if it is set 0W, it means no power can be exported to the grid; If it is set 2000W, it means the power exported to the grid can not exceed 2000W.

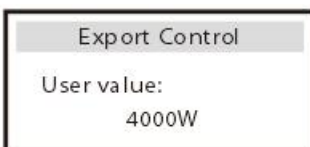

Mr GUO Huawei



R&D technical director

Date: - 2018-06-28

SolaX Power Network Technology (Zhe jiang) Co. , Ltd.

No.288 Shizhu Road, Tonglu Economic Development Zone, Tonglu City, Zhejiang Province, China.

Annex A Failsafe Tests

A1.Remove power to meter

Test Procedure	Remove power supply to Meter
Expected response	System turns off
Pass/fail criteria	System fails safe in less than 5s

- Test: Remove 230V AC supply to meter
- Scope: Yellow trace is AC voltage to Meter, green shows current at output of AC current
- Reaction time: 4.34s
- Pass/fail: **PASS**

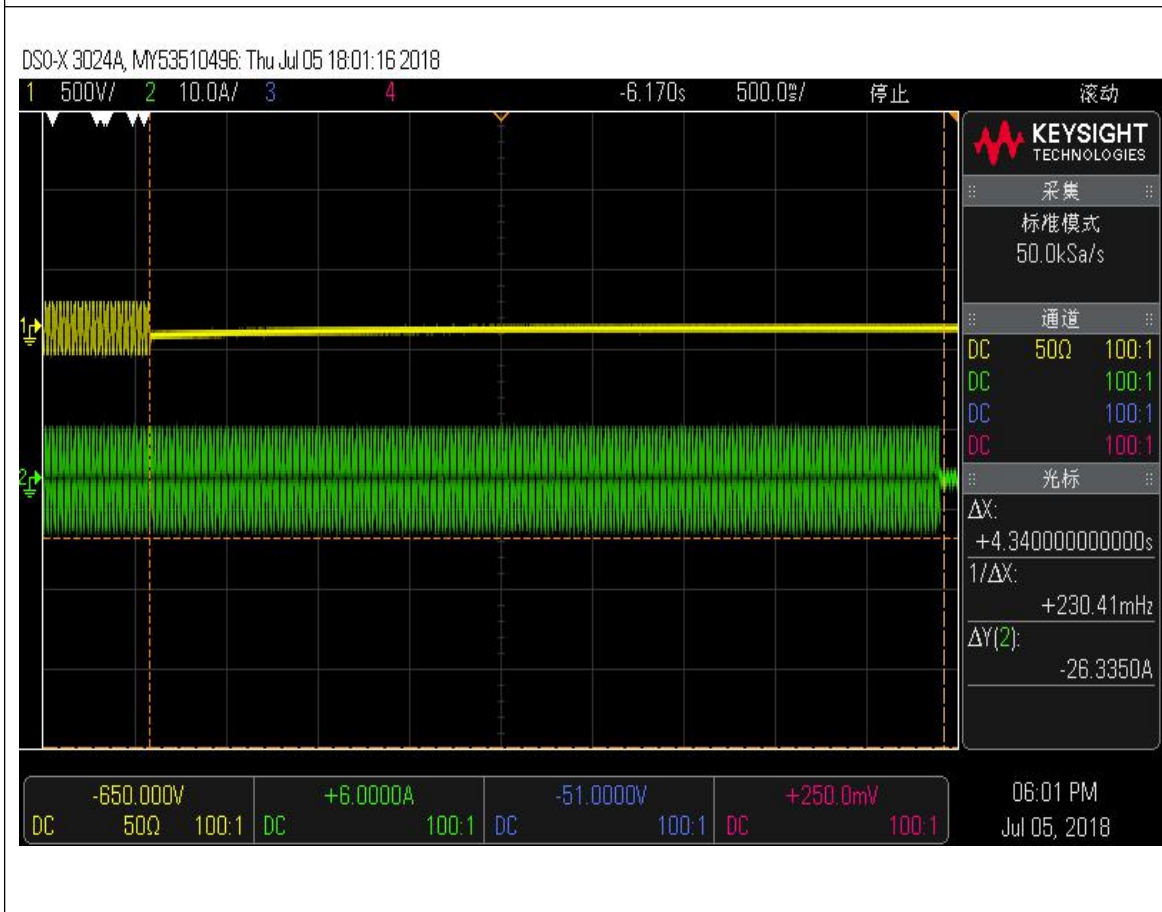

A2. Unplug communications cable between Inverter and Meter

Test Procedure	Unplug communications cable between Inverter and Meter
Expected response	System turns off
Pass/fail criteria	System fails safe in less than 5s

- Test: Unplug communications cable between Inverter and Meter
- Scope: Yellow trace is RS485 communications from the Meter , green shows current at output of AC current
- Reaction time: 4.26s
- Pass/fail: **PASS**

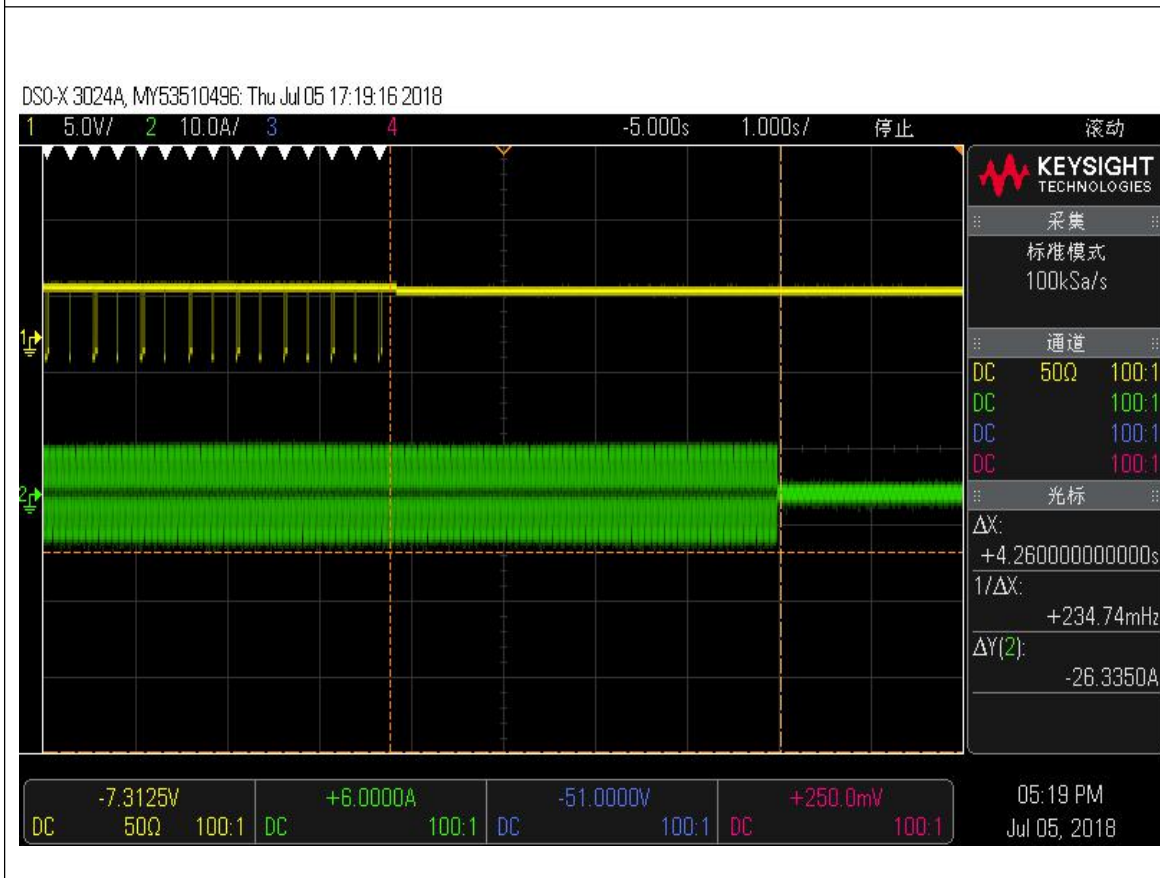

A3. Unplug communications cable between Inverter and Battery

Test Procedure	Unplug communications cable between Inverter and Battery
Expected response	System turns off
Pass/fail criteria	System fails safe in less than 5s

- Test: Unplug communications cable between Inverter and Battery
- Scope: Yellow trace is RS485 communications from the Battery, green shows current at output of AC current
- Reaction time: 4.14s
- Pass/fail: **PASS**

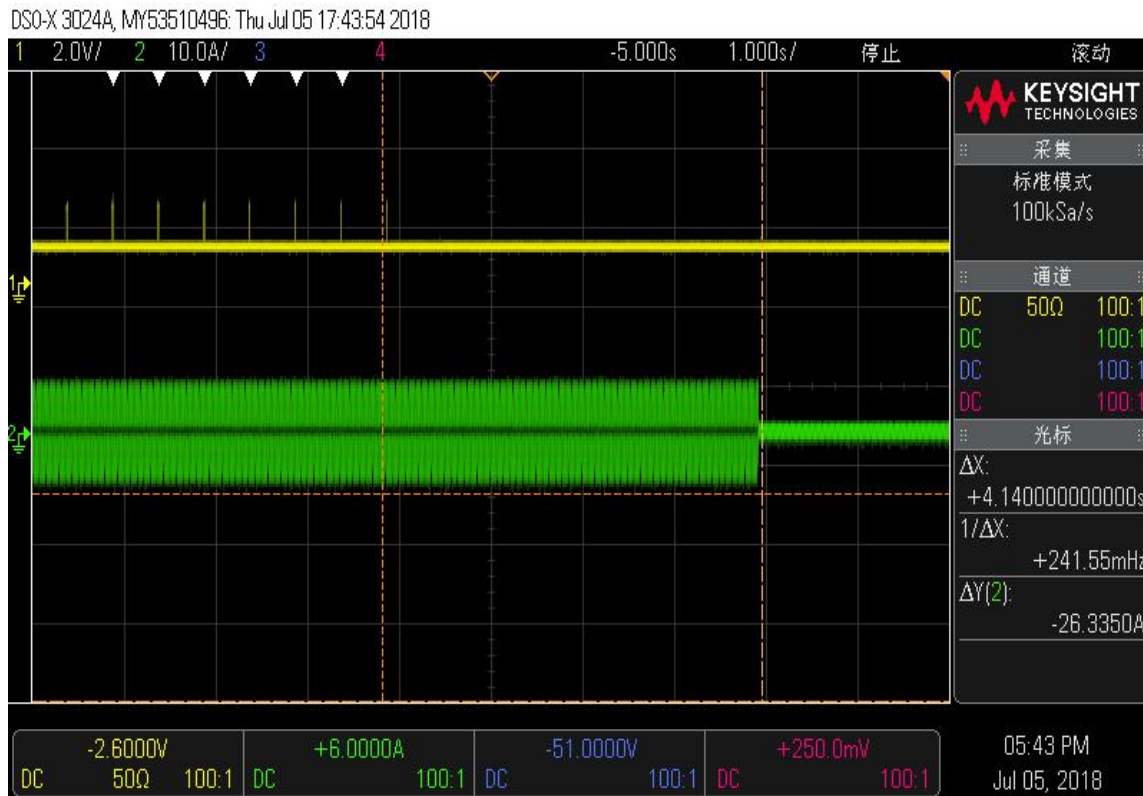

Password protection

All X1-Retro Fit Series inverter export limit settings are password protected.

LCD display operation

Customer should set “export control” function on the LCD display. “Export Control” setting can be found according to path below.

- Menu — Setting — Advanced — On-grid — Export Control.

Setting path

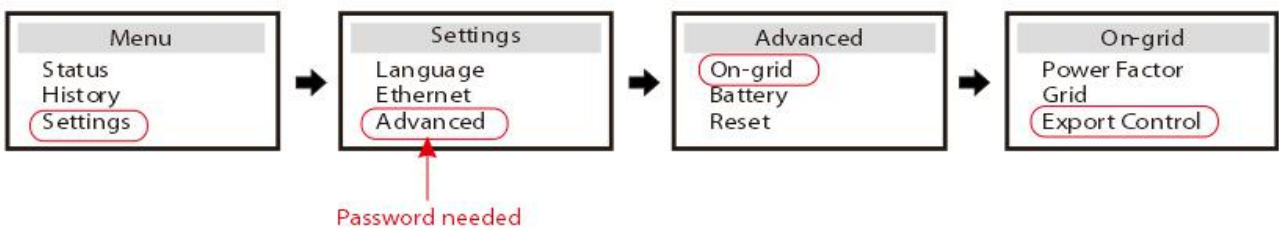
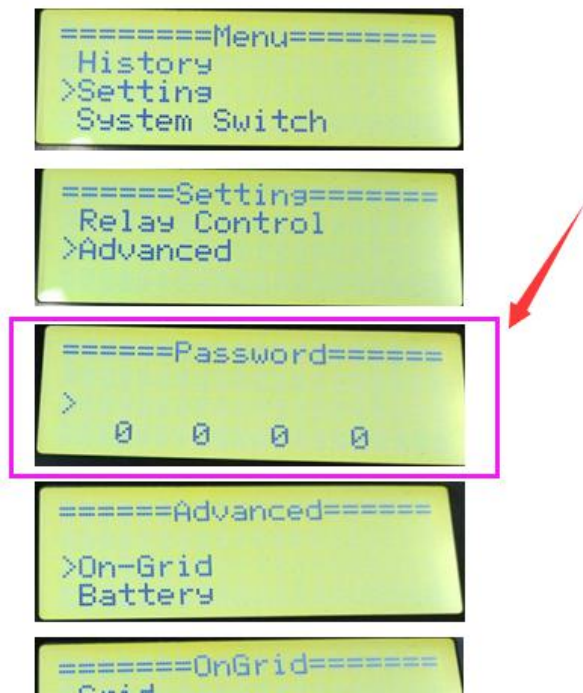

- This value can be set from 0-6000W.
For example, if it is set 0W, it means no power can be exported to the grid; if it is set 2000W, it means the power exported to the grid can not exceed 2000W.

Setting path

