

SOLAR MOUNTING SOLUTION FOR SLATE ROOFS



THE FASTENSOL SLATE MATE.



DESIGNED BY INSTALLERS, FOR INSTALLERS.

The Fastensol Slate Mate is the discreet easy way to swiftly mount on-roof solar systems to any slate roof. Designed by installers, for installers, The Fastensol Slate Mate can be installed in a few easy steps. With a 12-year durability warranty and full MCS accreditation, you can ensure that your solar system will be safely secured onto any slate rooftop.

**The only MCS dedicated roof anchor hook.
The MCS number is MCS IK0251.**

FEATURES

- Suitable for pitched and flat roofs
- Cladding type: Slate
- Maximum slope: 60 degrees
- Wind load: up to 60m/s
- Snow load: 2.0kn/m²
- Maximum building height: 20m
- Material: Stainless Steel
- MCS 012 certification
- Quick and simple solar installations on slate roofs. No cutting, no sealants and no leaks.
- Warranty: 12 years durability on material, 5 years on finish

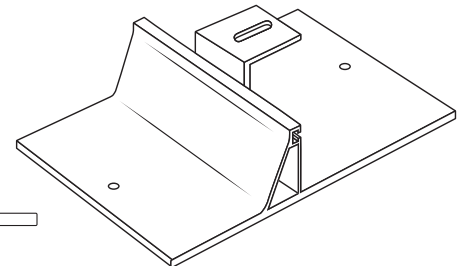
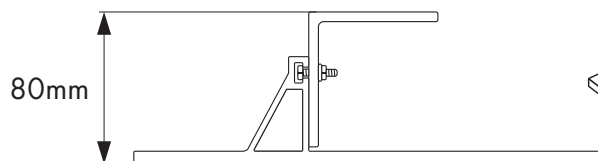
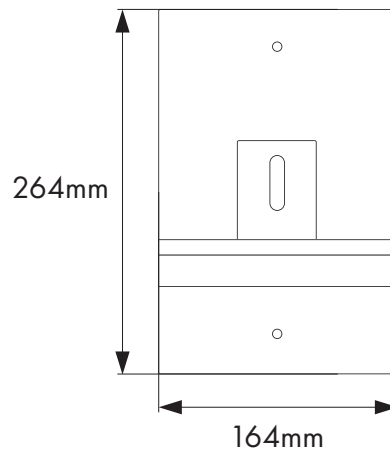

INSTALLATION PROCESS

Installing is as easy as 8 simple steps

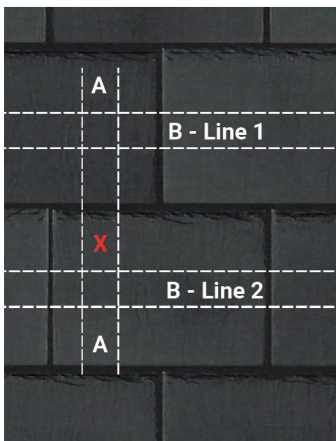

Step 1.

After locating the battens, B Line 1 & B Line 2 and rafter A positions. Mark the test hole position X as shown, away from the two battens marked.

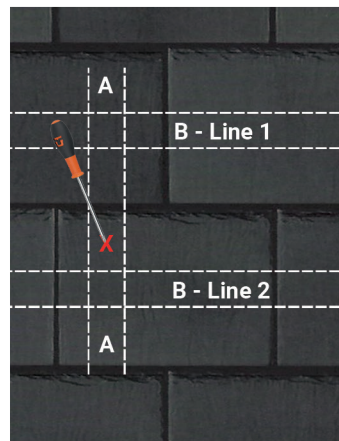

Step 2.

Drill out a 7mm test hole, using a screwdriver, gently. This is to confirm the rafters central position.

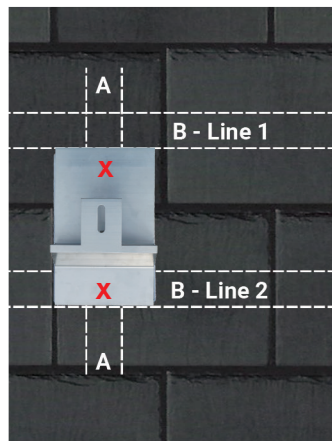

Step 3.

Place the plastic base in the fixing position as shown. Hold and drill through the 2 fixing points marked as X, use a 7mm tile drill, apply enough to mark the slate surface.

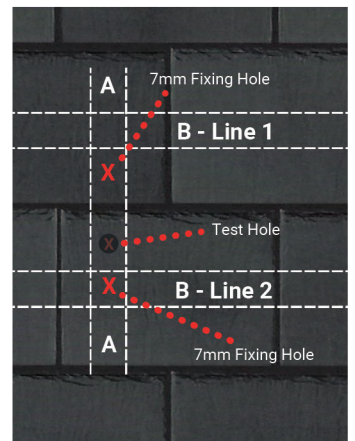

Step 4.

Drill out the two marked fixing hole positions with a 7mm tile drill.

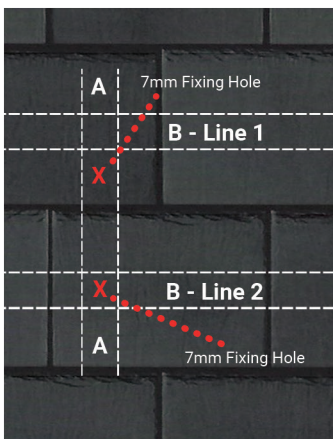

Step 5.

Drill out the 7mm fixing holes to 10mm.

Please Note - Drill the fixing holes 10mm, but NOT the test hole, this should be left at 7mm.

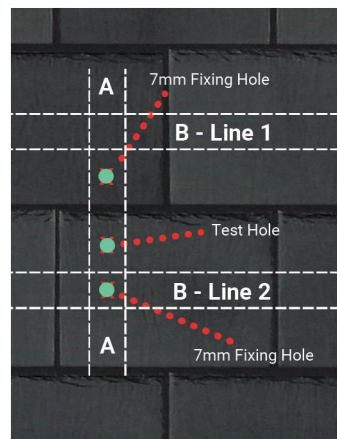

Step 6.

Apply CT1 sealant into and around the two fixing holes and test hole.

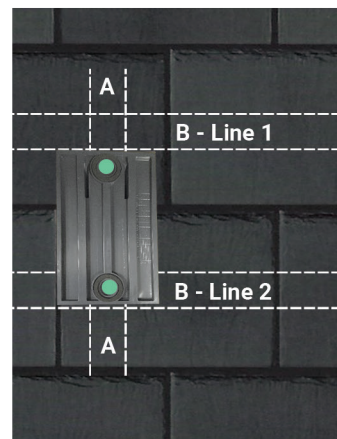

Step 7.

Apply CT1 sealant around the back of the two fixing holes on the plastic bracket.

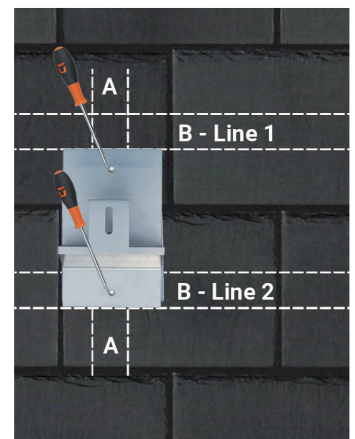

Step 8.

Fix the plastic bracket by using 2 x 6.3*100mm wooden screw, then apply the CT1 sealant around the top of 2 wooden screws again.

TECHNICAL SPECIFICATION

MCS 012 - Pitched Roof Installation Kits - Issue 2.4

Product Name	Description	Reference No.
A-SLATE	Above Roof Component	MCS IK0251/04

System information:

Weathertightness

Compatible roof coverings	Slates
Minimum permissible roof pitch	15°

Resistance to Wind Uplift

Compatible roof substrates	Timber (50mm minimum rafter or batten thickness)
Test set up	Component test - 1 A-Slate base (FSD460) including L-bracket (FSD461) attached with 2x6.5*100mm screws (FSD465) on to ungraded timber with slate roof covering
Maximum design wind uplift resistance	4928.5 N per bracket
Partial safety factor	1.1

Fire Performance

Fire classification	Not applicable
Fire classification achieved with	Not applicable

Certificated Components:

A-Slate base [265*164*5mm] (FSD460)	Neoprene gasket [265*164*2mm] (FSD464)
A-Slate L-bracket (FSD461)	Screw [6.5*100mm] (FSD465)
L-bracket nut (YGG123937)	Nylon spacer [20mm, 10mm OD, 8.2mm ID] (Spacer)
L-bracket bolt [A2 M8*25mm] (YGG100048)	C-Tec CT1 sealant (CT1 sealant)

MCS 012 - Pitched Roof Installation Kits - Issue 2.4

Product Name	Description	Reference No.
P-SLATE	Above Roof Component	MCS IK0251/05

System information:

Weathertightness

Compatible roof coverings	Slates
Minimum permissible roof pitch	15°

Resistance to Wind Uplift

Compatible roof substrates	Timber (50mm minimum rafter or batten thickness)
Test set up	Component test - 1 P-Slate base (FSD356) including L-bracket (FSD357) attached with 2x6.5*100mm screws (FSD465) on to ungraded timber with slate roof covering
Maximum design wind uplift resistance	1059.9 N per bracket
Partial safety factor	1.44

Fire Performance

Fire classification	Not applicable
Fire classification achieved with	Not applicable

Certificated Components:

P-Slate base [265*164*10mm] (FSD356)	Neoprene gasket [265*164*2mm] (FSD464)
P-Slate L-bracket (FSD357)	Screw [6.5*100mm] (FSD465)
L-bracket washer (SHD141667)	Nylon spacer [20mm, 10mm OD, 8.2mm ID] (Spacer)
L-bracket nut (SLF100138)	C-Tec CT1 sealant (CT1 sealant)
L-bracket bolt [A2 M8*35mm] (215607)	