

User Manual

High Voltage LFP Battery

SBS050



All Rights Reserved

All Rights Reserved

No part of this document can be reproduced in any form or by any means without the prior written permission of Sungrow Power Supply Co., Ltd (hereinafter "SUNGROW").

Trademarks

SUNGROW and other SUNGROW trademarks used in this manual are owned by SUNGROW.

All other trademarks or registered trademarks mentioned in this manual are owned by their respective owners.

Software Licenses

- It is prohibited to use data contained in firmware or software developed by SUNGROW, in part or in full, for commercial purposes by any means.
- It is prohibited to perform reverse engineering, cracking, or any other operations that compromise the original program design of the software developed by SUNGROW.

About This Manual

The manual mainly describes the product information, guidelines for installation, operation and maintenance. The manual cannot include complete information the system (i.e. the hybrid inverter), just the battery. The reader can get additional information about other devices at www.sungrowpower.com or on the webpage of the respective component manufacturer.

Validity

This manual is valid for the following battery models:

- SBS050

They will be referred to as "battery" hereinafter unless otherwise specified.

Target Group

This manual is intended for battery owners who will have the ability to interact with the battery and qualified personnel who are responsible for the installation and commissioning of the battery. Qualified personnel should have the following skills:

- Training for installation and commissioning of electrical system, as well as dealing with hazards
- Knowledge of the manual and other related documents
- Knowledge of the local regulations and directives

How to Use This Manual

Read the manual and other related documents before performing any work on the battery. Documents must be stored carefully and be available at all times.

Images in this manual are for reference only. The actual product received may differ.

Contents may be periodically updated or revised due to the product development. It is probably that there are changes of manual in the subsequent battery edition. The latest manual can be acquired via visiting the website at support.sungrowpower.com.

Symbols

Important instructions contained in this manual should be followed during installation, operation and maintenance of the battery. They will be highlighted by the following symbols.

DANGER

Indicates a hazard with a high level of risk that, if not avoided, will result in death or serious injury.

WARNING

Indicates a hazard with a medium level of risk that, if not avoided, could result in death or serious injury.

CAUTION

Indicates a hazard with a low level of risk that, if not avoided, could result in minor or moderate injury.

NOTICE

Indicates a situation that, if not avoided, could result in equipment or property damage.



Indicates additional information, emphasized contents or tips that may be helpful, e.g. to help you solve problems or save time.

Abbreviation

BMS: Battery Management System

CAN: Controller Area Network

LFP: Lithium iron phosphate

SOC: State of Charge

PACK: Battery module

Contents

All Rights Reserved.....	I
About This Manual.....	II
1 Safety Instructions.....	1
1.1 Notices for Safe Use.....	2
1.2 Battery Handling Information.....	3
1.3 Emergency Situations.....	4
1.3.1 Leaking Batteries.....	4
1.3.2 Fire.....	5
1.3.3 Wet Batteries.....	6
1.3.4 Damaged Batteries.....	6
2 Product Description.....	7
2.1 System Introduction.....	7
2.2 Product Introduction.....	7
2.3 Signs on the Product.....	10
2.4 LED Indicator.....	11
3 Unpacking and Storage.....	13
3.1 Unpacking and Inspection.....	13
3.2 Scope of Delivery.....	14
3.3 Storage.....	15
4 Mounting.....	17
4.1 Safety during Mounting.....	17
4.2 Location Requirements.....	17
4.3 Installation Tools.....	19
4.4 Installing the Battery.....	20
4.4.1 Floor-Mounted Against the Wall.....	20
4.4.2 Mounted on the Wall.....	24
4.4.3 Aligned Front to Back (Cascading).....	26

5 Electrical Connection	29
5.1 Safety Instructions.....	29
5.2 Terminal Description.....	30
5.3 Electrical Connection Overview.....	30
5.4 PE Cable Connection.....	32
5.5 DC Cable Connection.....	33
5.5.1 Assembling the DC Connectors.....	33
5.5.2 Installing the DC Connectors.....	34
5.6 Communication Cable Connection.....	35
5.6.1 Assembling the Communication Connectors.....	35
5.6.2 Installing the Communication Connectors.....	38
5.7 Matching Resistor Connection.....	38
5.7.1 Assembling the Matching Resistor.....	38
5.7.2 Installing the Matching Resistor.....	40
5.8 Battery Cascading.....	40
5.8.1 Side-by-Side Arrangement.....	40
5.8.2 Front-to-Back Arrangement.....	40
6 Commissioning/Start-up	42
6.1 Inspection before Commissioning.....	42
6.2 Commissioning Procedure.....	42
7 Decommissioning/Shutdown	44
8 Viewing Battery Information	45
9 Battery Augmentation	50
10 Troubleshooting and Maintenance	55
10.1 Troubleshooting.....	55
10.2 Maintenance.....	60
11 Appendix	62
11.1 Technical Data.....	62
11.2 FAQs.....	63
11.2.1 Battery Not Charging.....	63
11.2.2 Battery Not Discharging.....	64
11.2.3 SOC Jump.....	64
11.2.4 Battery Update.....	65

11.3 Quality Assurance.....65
11.4 Contact Information.....66

1 Safety Instructions

When installing, commissioning, operating, and maintaining the product, strictly observe the labels on the product and the safety requirements in the manual. Incorrect operation or work may cause:

- Injury or death to the operator or a third party.
- Damage to the product and other properties.

WARNING

- **Do not perform any operation on the product (including but not limited to, handling, installing, powering on, or maintaining the product, performing electrical connection, and working at heights) in harsh weather conditions, such as thunder and lightning, rain, snow, and Level 6 or stronger winds. SUNGROW shall not be held liable for any damage to the device due to force majeure, such as earthquakes, floods, volcanic eruptions, mudslides, lightning strikes, fires, wars, armed conflicts, typhoons, hurricanes, tornadoes, and other extreme weathers.**
- **In case of fire, evacuate from the building or product area and call the fire alarm. Re-entry into the burning area is strictly prohibited under any circumstances.**

NOTICE

- **Tighten the screws with the specified torque using tools when fastening the product and terminals. Otherwise, the product may be damaged. And the damage caused is not covered by the warranty.**
- **Learn how to use tools correctly before using them to avoid hurting people or damaging the device.**
- **Maintain the device with sufficient knowledge of this manual and use proper tools.**



- The safety instructions in this manual are only supplements and cannot cover all the precautions that should be followed. Perform operations considering actual onsite conditions.
- SUNGROW shall not be held liable for any damage caused by violation of general safety operation requirements, general safety standards, or any safety instruction in this manual.
- When installing, operating, and maintaining the product, comply with local laws and regulations. The safety precautions in this manual are only supplements to local laws and regulations.
- During the product transport, installation, wiring, maintenance, etc., the materials and tools prepared by users must meet the requirements of applicable local laws and regulations, safety standards, and other specifications. SUNGROW shall not be held liable for any damage to the product caused by the adoption of materials and tools that fail to meet the above-mentioned requirements.
- Operations on the product, including but not limited to, handling, installing, wiring, powering on, maintenance, and use of the product, must not be performed by unqualified personnel. SUNGROW shall not be held liable for any damage to the product resulting from operations done by unqualified personnel.
- Where the transport of the product is arranged by users, SUNGROW shall not be held liable for any damage to the product that is caused by users themselves or the third-party transport service providers designated by the users.
- SUNGROW shall not be held liable for any damage to the product caused by the negligence, intent, fault, improper operation, and other behaviors of users or third-party organizations.
- SUNGROW shall not be held liable for any damage to the product arising from reasons unrelated to SUNGROW.

1.1 Notices for Safe Use

Read all safety instructions carefully prior to any work and observe them at all times when working on or with the battery. Failure to observe the precautions described in this section can cause serious injury to persons or damage to property.

⚠ DANGER**Risk of explosion**

- Do not subject the battery to any strong force.
- Do not mechanically damage the battery (pierce, deform, strip down, etc.)
- Do not heat the battery or dispose of the battery in a fire.
- Do not install the battery in potentially explosive environments.
- Do not place the battery in water or other liquids.

⚠ DANGER**Risk of fire**

- Do not place the battery near a heat source, such as direct sunlight, a fireplace, a thermally uninsulated wall exposed to sunlight, hot water, or a heater.
- Keep sources of ignition such as sparks, flames, and smoking materials away from the battery.

⚠ DANGER**Risk of electric shock**

- Do not disassemble the battery.
- Do not handle a wet battery or use wet tools.
- Do not soak the battery in water or expose it to moisture or liquids.
- Keep the battery away from children and animals.
- Wear suitable clothing, guards and gloves to prevent you from direct contact with the DC voltage.
- Use insulated tools during working with battery.
- Set aside metal jewelry before working on the DC circuit.

1.2 Battery Handling Information

NOTICE

Follow local standards to use the battery.

Any man-made damage will void the limited warranty for the battery. Handle the battery with care to protect it from damage.

- Use the battery only as intended and designed.
- The battery must only be installed at a suitable location.
- Make sure the battery is well connected to ground before use.
- Do not use the battery if it is defective, appears cracked, broken or damaged, or fails to operate.
- Do not use the battery together with other types of batteries.
- Do not pull, drag or step on the battery.
- Do not leave any foreign objects inside the battery.
- Do not repair or modify the battery. It is not user serviceable.
- Do not pull out any cables when the battery is powered on.
- Do not damage the sheath of cables, wire harness and connectors.
- While the battery is charged, used and stored, keep it away from materials that are prone to electric discharge, including static discharge.
- Keep the battery away from babies and children to avoid any accidents.
- Cover terminals with insulating tape before proper disposal.
- Avoid direct contact with rain, snow, and water, and prevent the battery from falling and mechanical impact during battery transportation.

1.3 Emergency Situations

1.3.1 Leaking Batteries

Abuse/misuse/damage of the battery may cause increasing of internal pressure in the battery cells. It may result in the electrolyte venting. In the event that battery electrolyte is released:

- Do not enter the room under any circumstance.
- Avoid contact with the leaking liquid or gas.
- Call the Local Emergency number or Fire Brigade if necessary.

If one is exposed to the leaking substance, follow the suggestions below to minimize the chance of injury:

- Inhalation: Evacuate the contaminated area, and seek medical aid.
- Eye contact: Rinse eyes with copious amounts of water for at least 15 minutes, and seek medical aid immediately.

- Skin contact: Wash the affected area thoroughly with plenty of water for at least 15 minutes. If possible, remove or saturate contaminated clothing with water. Seek medical aid if the patient is distressed.
- Ingestion: Induce vomiting, and seek medical aid immediately.

Wipe out the contacted area with a sponge or cloth that is soaked in water until you obtain medical aid. These materials can damage skin and eyes, causing blindness.

1.3.2 Fire

Fire may occur with the battery despite its careful design. Likewise, a fire or unusually high temperatures near the battery can cause it to catch fire.

Protective equipment

A respirator is not required during normal operations.

In the event of a fire, hazardous fumes including carbon monoxide, carbon dioxide, and/or various hydrocarbons may be emitted. To comply with the Personal Protective Equipment Directive (89/686/EEC), use a full-face self-contained breathing apparatus (SCBA) with full protective gear during fire fighting.

Fire fighting

NOTICE

In the event of a fire, only qualified firefighters with appropriate protective equipment are permitted to enter the room where the battery is located.

It may take a long time to completely extinguish the fire. Consider allowing the system to burn. Smoke indicates that the battery is still burning. Always note that there is a risk of the battery re-igniting.

Proceed as follows for fire-fighting.

1. Shut off any connected power system or electronics such as the battery, battery isolator, PV DC isolator(s), AC isolator, solar supply main switch and normal supply main switch.
2. Perform an adequate knock down on the fire before entering the incident's hot zone.
3. If the battery catches on fire, use fire-fighting sand, CO₂ extinguisher, or other emergency fire extinguishing equipment approved by fire fighters to extinguish the fire.
4. If the fire is not from the battery and has not spread to it yet, use an ABC fire extinguisher to extinguish the fire. Remove batteries and other ignition sources from the scene of a fire.

1.3.3 Wet Batteries

If the battery is submerged in water, do not let people access it, and then contact Sungrow or an authorized service partner for technical support.

If a battery is submerged in water or flooded, first, switch off all circuit breakers in the system to cut off the power supply to the battery. Wait until floodwaters subside and do not approach near battery. If someone needs to go into the flooded water, wear insulated full length rubber boots and gloves.

Do not use a flooded battery again.

1.3.4 Damaged Batteries

The battery consists of lithium-ion cells. These are considered dry cell batteries. If the battery is damaged, only a small amount of battery fluid can leak.

A damaged battery can cause rapid heating of the battery cells. If you notice smoke coming from the battery area, assume that the battery is burning and take appropriate action as described in [1.3.2 Fire](#).

Damaged batteries are dangerous and must be handled with extreme caution. They are not fit for use and may pose a danger to people or property. If a battery seems to be damaged:

1. Pack it in its original container.
2. Store it in a separated room like the installation place.
3. Contact SUNGROW.

DANGER

A damaged battery may release dangerous material and a flammable gas mixture. Never try to repair the battery even if you are a qualified electrician.

2 Product Description

2.1 System Introduction

The SBS050 high-voltage battery system is a vital component of the PV power generation system. It works in conjunction with the hybrid inverter to store energy for later use in various applications.

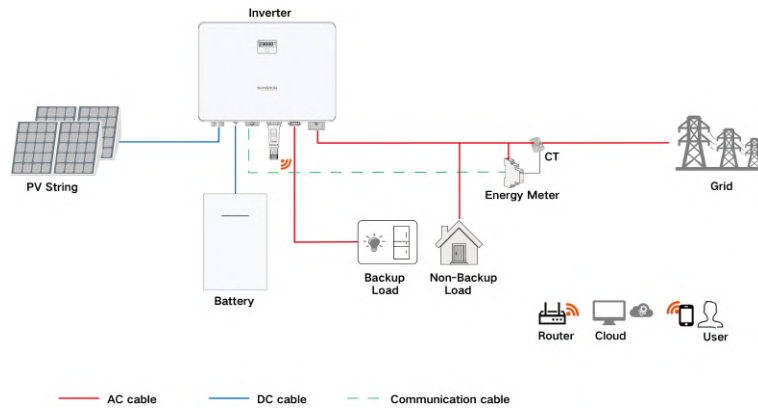

figure 2-1 System Diagram

2.2 Product Introduction

Product Model

The definition of the product model "SBS050" is introduced below.

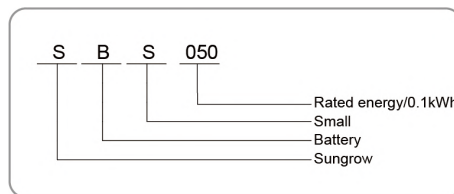
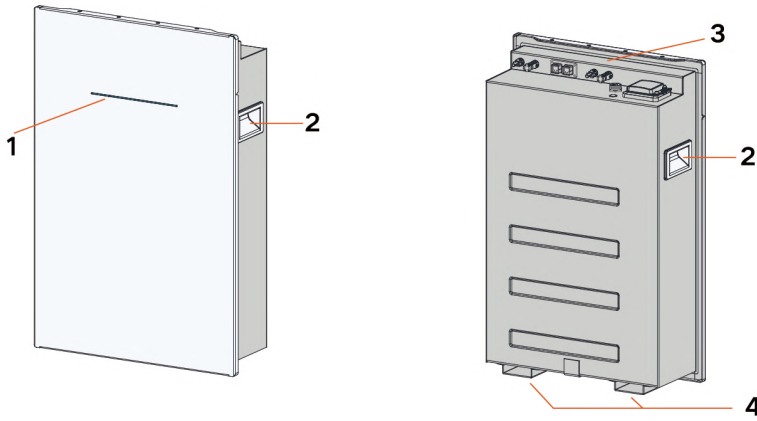

figure 2-2 Product Model

External Design



1: LED indicator

2: Handle

3: Wiring area

4: Foot



*The figures shown are for illustration purposes only. The actual product may differ.

Terminal Description

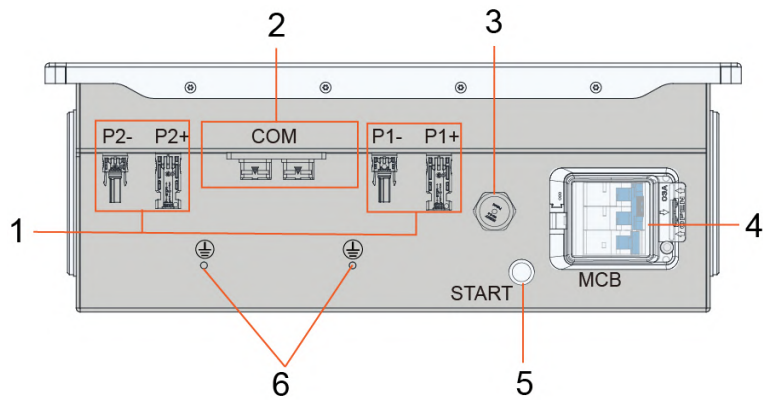



figure 2-3 Terminals

No.	Definition	Label	Description
1	Battery DC input terminal	P1+/P1-/P2+/P2-	P1+/P2+: Connected to the positive terminal of the hybrid inverter or that of the battery added for capacity expansion (battery cascading) P1-/P2-: Connected to the negative terminal of the hybrid inverter or that of the battery added for capacity expansion (battery cascading)
2	Communication terminal	COM	Communication port; connected to the hybrid inverter or the battery added for capacity expansion (battery cascading)
3	Explosion relief valve	/	Designed to prevent battery explosion due to excessive pressure under abnormal conditions, such as overcharging, overdischarging, or external short circuits
4	DC circuit breaker	MCB	Used to turn on/off the battery, as well as provide short-circuit protection, by breaking or closing the DC circuit
5	Black start button	START	Used for the black start of the battery
6	Protective grounding (PE) terminal		Used for reliable grounding of the battery

Dimensions

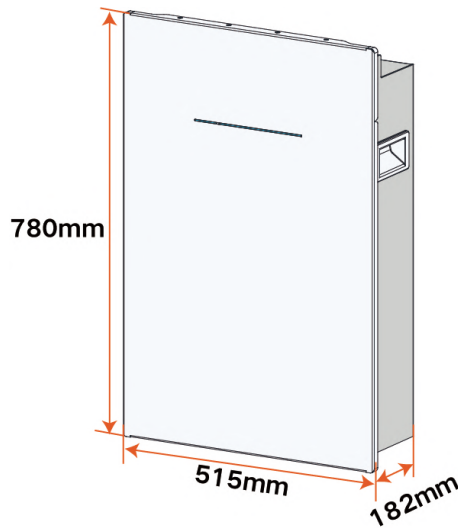



figure 2-4 Dimensions



*The figures shown are for illustration purposes only. The actual product may differ.

2.3 Signs on the Product

Sign	Definition
	Danger! Do not work on the product when it carries voltage.
	No open flames! Avoid exposure to flames, incineration, punctures, or impacts.
	Electric shock hazard! Service must be performed only by qualified personnel. Keep it out of reach of children.
	CE mark of conformity. EU/EEA importer.
	Do not dispose in trash. Compacting a lithium ion battery is dangerous as it can explode.
	Please recycle this lithium ion battery. Do not discard.

Sign	Definition
	Read through the user manual before maintenance.
	This is a protective grounding terminal, which should be grounded securely to protect the safety of operators

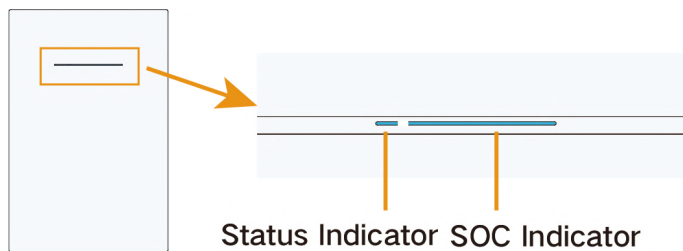

2.4 LED Indicator

The battery is equipped with two LED indicators, status indicator and SOC indicator.



Status Indicator





The status indicator indicates the current status of the battery, as shown in the table below.

Status indicator	Color	Status	Description
	Blue	Steady on	The battery operates properly.
		Blink slow (at an interval of 1s)	The battery is starting up or in standby mode.
		Blink fast (at an interval of 0.5s)	The battery is being updated, tested, or calibrated.
	Red	Steady on	There is a fault in the battery.
		Blink slow (at an interval of 1s)	There is an alarm in the battery.
	Grey	Off	The battery is turned off.

SOC Indicator

The SOC indicator indicates the current SOC of the battery. It is designed with 5 bars in total, each for 20% SOC.

SOC Indicator	SOC
	0

SOC Indicator	SOC
	$0 < \text{SOC} \leq 20\%$
	$20\% < \text{SOC} \leq 40\%$
	$40\% < \text{SOC} \leq 60\%$
	$60\% < \text{SOC} \leq 80\%$
	$\text{SOC} > 80\%$



*The figures shown are for illustration purposes only. The actual product may vary.

3 Unpacking and Storage

3.1 Unpacking and Inspection

The product is thoroughly tested and strictly inspected before delivery. Nonetheless, damage may still occur during shipping. For this reason, please conduct a thorough inspection after receiving the product.

- Check the packing case for any visible damage.
- Check the scope of delivery for completeness according to the packing list.
- Check the inner contents for damage after unpacking.

Contact SUNGROW or the transport company in case of any damage or incompleteness, and provide photos to facilitate services.

Do not dispose of the original packing case. It is recommended to store the device in the original packing case when the product is decommissioned.

NOTICE

- **After receiving the product, check whether the appearance and structural parts of the device are damaged, and check whether the packing list is consistent with the actual ordered product. If there are problems with the above inspection items, do not install the device and contact your distributor first. If the problem persists, contact SUNGROW in time.**
- **If any tool is used for unpacking, be careful not to damage the product.**

3.2 Scope of Delivery



Item	Name	Quantity
A	Battery	1
B	Expansion bolt	6
C	Mounting bracket	1
D	DC connector (battery side)	4
E	Communication connector (with RJ45 plug)	2
F	Screw	10
G	Mounting template	1
H	OT terminal	2
I	Network cable	1
J	Matching resistor	1
K	DC connector (hybrid inverter side)	2
L	Document	1
M	Waterproof plugs	1
N	Accessory brackets (for capacity expansion)	1

The accessory brackets are not included as standard but are available for separate purchase. These brackets are primarily used for front-to-back battery arrangement (for capacity expansion) and will be packaged separately.

DC connectors (hybrid inverter side) are applicable only to SH3.0/3.6/4.0/5.0/6.0/8.0/10.0RS hybrid inverters.

3.3 Storage

Proper storage is required if the battery is not installed immediately.

- Store the battery in its original packing case with desiccant inside.
- Store the battery in a clean and dry place, without exposure to direct sunlight and rain.
- The storage location must be free of harmful gases, flammables, explosives, and corrosive chemicals. The battery should be prevented from mechanical impacts, high pressure, high-intensity magnetic field, and direct exposure to sunlight.
- Preferably, keep the temperature in the range of 15°C - 25°C and install the battery as soon as possible. Store the battery within the temperature range of -10°C to 35°C. The storage time has to be ≤ 6 months, and the storage should not exceed 12 months.
- In ideal conditions the maximum storage time for the battery is 12 months. However due to uncertainties regarding the warehouse conditions for example temperature fluctuations outside the normal storage range, it is required to recharge the battery to 40% SOC every 6 months of storage.
- Handle the batteries with care.
- The relative humidity in the storage environment must be always between 0% and 95%, non-condensing.
- The packing and batteries should remain upright.
- Always use the oldest stored batteries first to ensure none are stored beyond their recommended period
- Lithium batteries are recommended to be recharged within 12 months of storage at recommended temperature or transportation
- Regularly inspect the packing case for damage, including damage caused by insects. If any damage is found, the product should be replaced immediately.



If the battery is stored for over one year, 5–8% of its capacity may lose permanently.



In case a battery needs to be charged, because it has been stored for more than 12 months, please gather necessary equipment such as an hybrid inverter, connecting cables and safety gear and follow chapters 4 to 5 of this user manual for a proper installation.

1. In the Energy Management Parameters, continue to set the compulsory charging mode in our iSolarCloud (Web-based version or App) of the hybrid inverter.

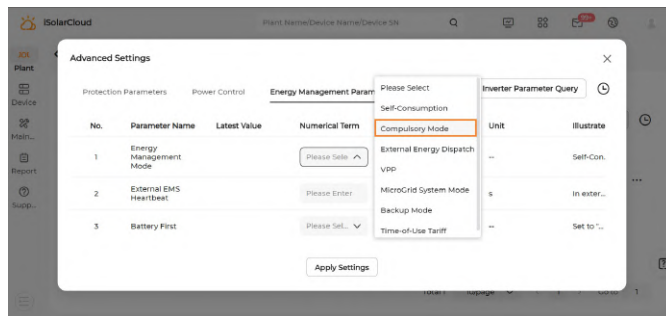

2. Set the lower SOC limit to 40%.

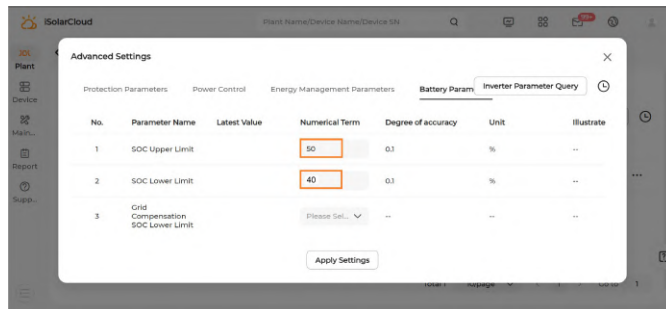

3. Select Charge as the charging command and an appropriate charging power. Monitor the charging process to ensure the SOC reaches 40%. Once charging is complete, disconnect the battery from the hybrid inverter safely.

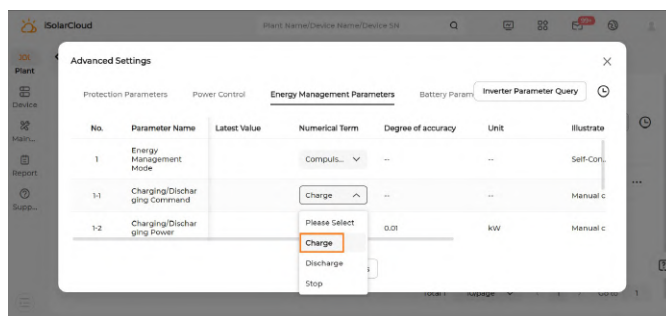

4 Mounting

4.1 Safety during Mounting

WARNING

This product or system must be operated by professionals!

Failure to follow the safety instructions in this manual or operation of this product or system by non-professionals may cause severe personal injury or major property damage.

WARNING

Strictly follow local relevant standards and requirements in the whole process of installation.

4.2 Location Requirements

Selecting an ideal location is crucial for ensuring the device's safe operation, long service life, and reliable performance.

- The IP65-rated battery can be installed both indoors and outdoors.
- Install the battery in a place convenient for electrical connection, operation and maintenance.
- Do not install the device in areas within 500 meters of the coastline or prone to sea winds. Otherwise, the battery may get corroded, thus resulting in fire.
- The installation environment must be free of inflammable or explosive materials.
- Keep the device out of the reach of children.

Installation Environment

- The battery should be well ventilated. Ensure air circulation.
- The temperature and humidity should meet the following requirements:

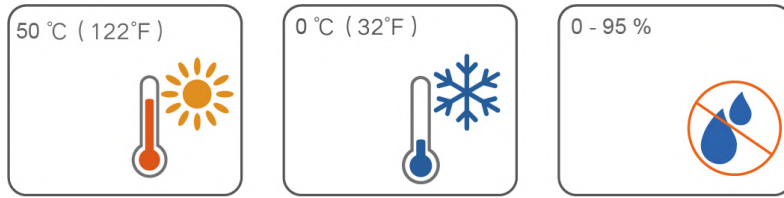

- Avoid direct exposure to sunlight, rain, and snow.



The battery may derate if the ambient temperature goes higher than 40°C.

Installation Angle

It is recommended to install the battery on the wall or on the floor against the wall. Do not install it at a tilt angle.

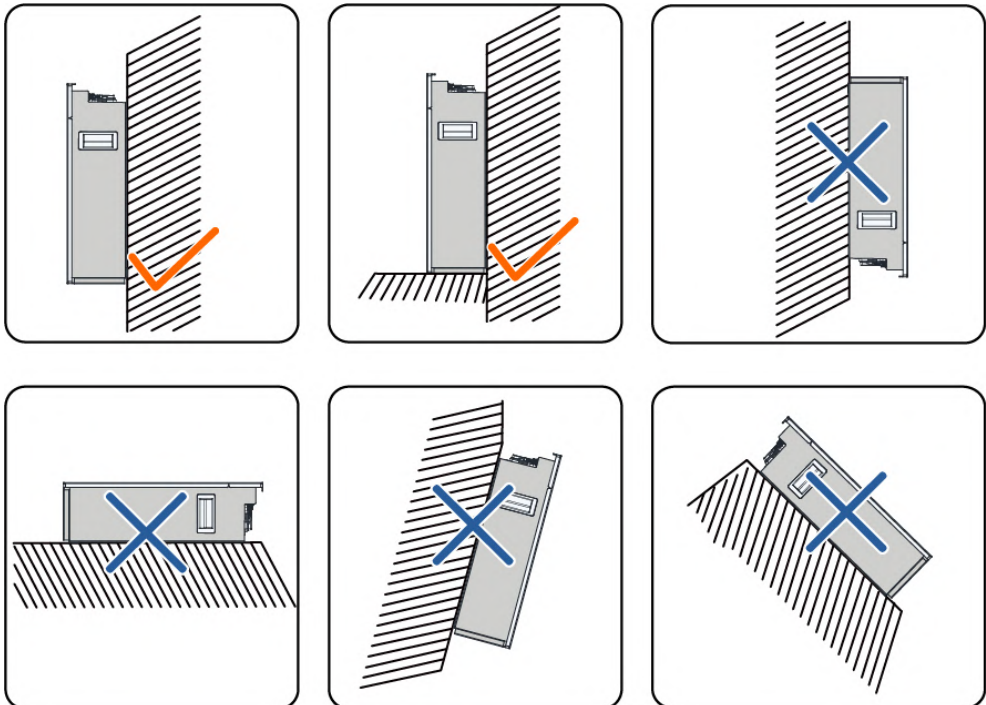

Installation Carrier

The battery should be positioned close to the wall and secured using the fixing bracket, so as to prevent it from tipping over.

The support structure, to which the battery is secured, should be fireproof and not made of flammable materials.

Please make sure the support structure is solid enough to hold the device.

Installation Space

Reserve sufficient space around the battery to ensure effective heat dissipation.

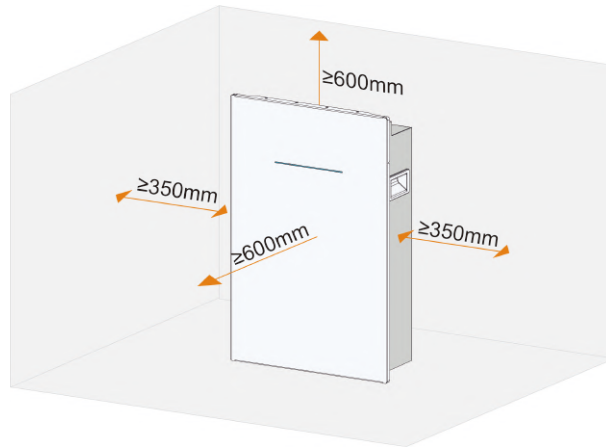
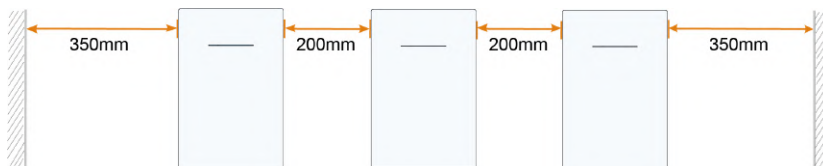

figure 4-1 Space Around the Battery

* This distance is the distance between the battery and the wall.

In case of multiple batteries, reserve sufficient space between the batteries as required.



4.3 Installation Tools

Installation tools include, but are not limited to, the following recommended ones. If necessary, use other auxiliary tools on site.

table 4-1 Tool specification



Goggles

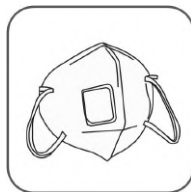

Dust mask



Safety gloves



Safety shoes



Utility knife



Marker



Rubber mallet



Measuring tape



Level

Hammer drill ($\varnothing 10$)Torque screwdriver
(ST6.3, M5, M6)Torque wrench
(8mm, 10 mm, 27mm)

Hydraulic pliers



Heat gun

Electric screwdriver
(ST6.3, M5, M6)Crimping
tool (10mm²,
cold-pressed
terminal)

Wire strippers



MC4 wrench



Two MC4 wrenches are required.

4.4 Installing the Battery

4.4.1 Floor-Mounted Against the Wall



Please install the battery on a flat surface in an open space.

step 1 Three mounting brackets are included in the battery accessories. Mounting brackets 1 and 3 should be attached to the battery, while mounting bracket 2 should be fitted onto the wall. Begin the installation by securing brackets 1 and 3 to the battery using M6 screws.

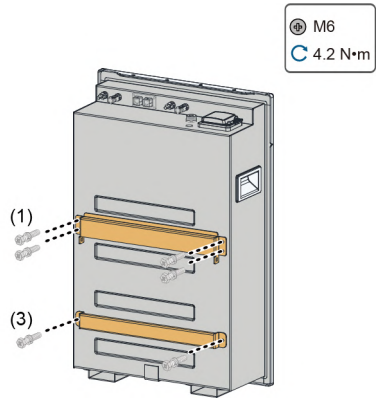
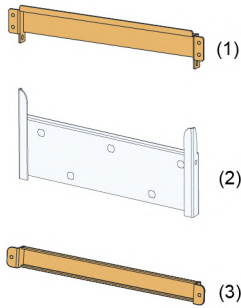

step 2 Fold the mounting template along the dashed line.

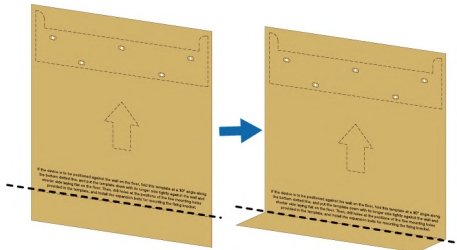

step 3 Position the mounting template on the floor, and mark the hole positions on the wall according to the mounting holes indicated on the template.

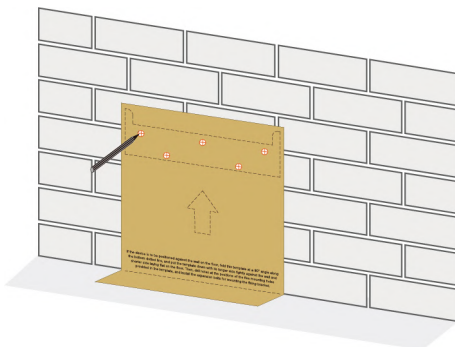

step 4 Drill holes at the marked positions, then insert the expansion sleeves into the holes.

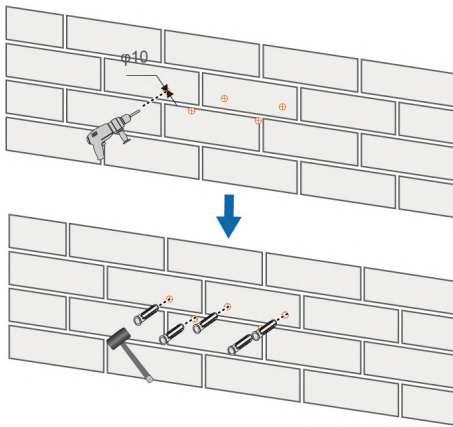

NOTICE

Wear goggles and masks while drilling holes to protect your eyes and respiratory system from dust and dirt. Clean the dust and debris around in time after finishing drilling.

step 5 Fit mounting bracket 2 onto the wall using ST6.3 screws.

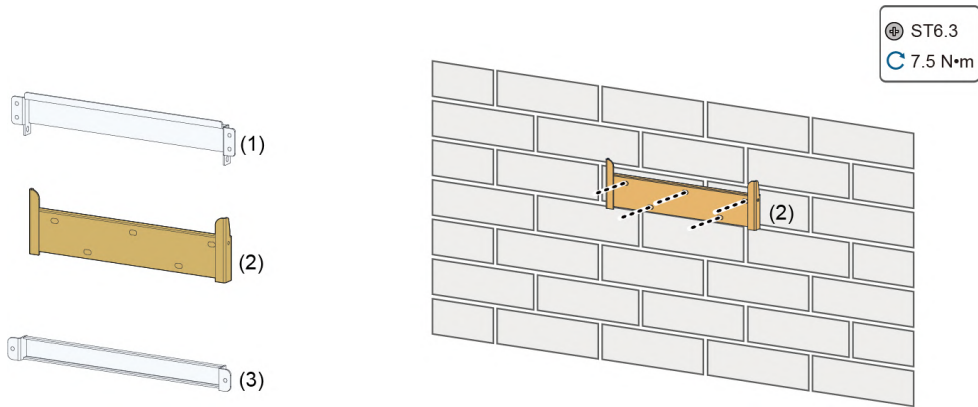

step 6 Hang the battery onto the mounting bracket on the wall from top to bottom. Ensure that mounting brackets 1 and 2 align properly and tightly against each other, then secure them together with M6 screws.

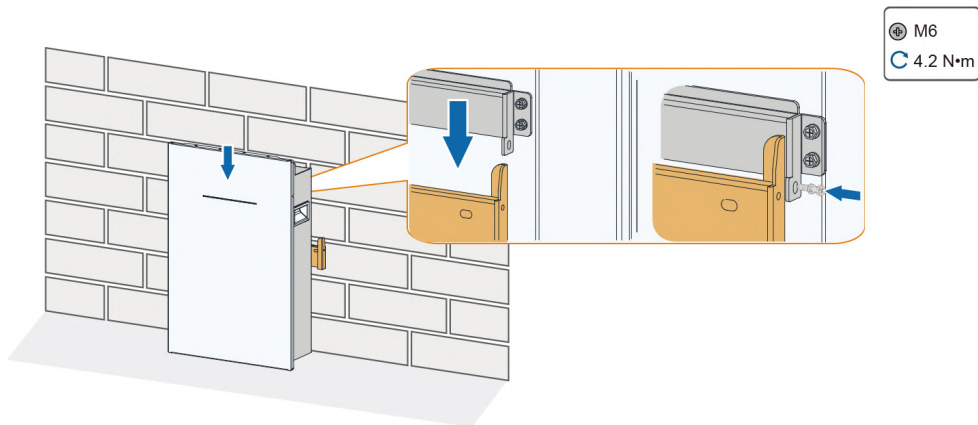

-- End

step 3 Drill holes at the marked positions, then insert the expansion sleeves into the holes.

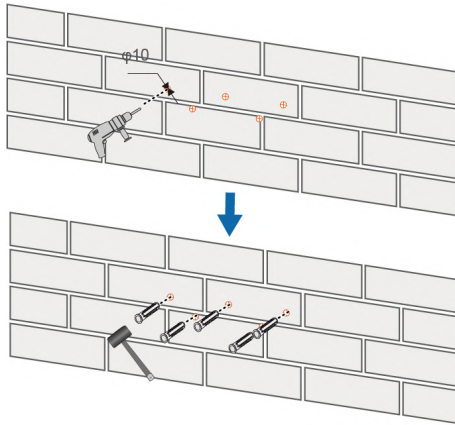

NOTICE

Wear goggles and masks while drilling holes to protect your eyes and respiratory system from dust and dirt. Clean the dust and debris around in time after finishing drilling.

step 4 Fit mounting bracket 2 onto the wall using ST6.3 screws.

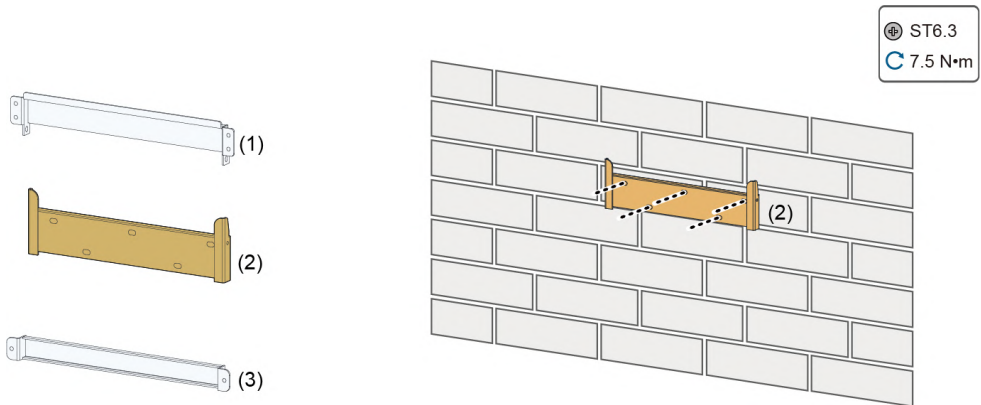

step 5 Hang the battery onto the mounting bracket on the wall from top to bottom. Ensure that mounting brackets 1 and 2 align properly and tightly against each other, then secure them together with M6 screws.

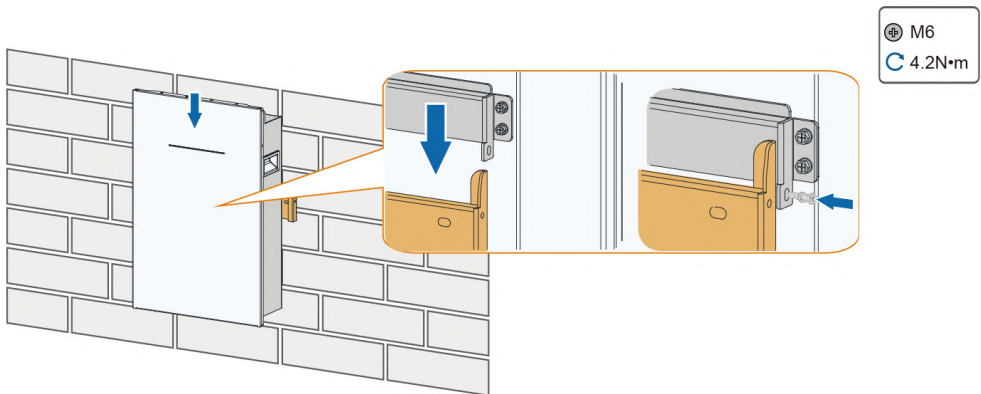

-- End

4.4.3 Aligned Front to Back (Cascading)

The batteries can be installed with one behind the other for capacity expansion (battery cascading). In these applications, ensure that the ground is flat and even and the two batteries are positioned at the same height.

step 1 Battery B should be installed on the floor against the wall. For details, see [4.4.1 Floor-Mounted Against the Wall](#).

step 2 Three brackets are included in the accessory pack for capacity expansion. Accessory bracket b should be attached to the battery, while accessory brackets a and c are used in conjunction with

bracket b to secure the two batteries together. Begin the installation by attaching bracket b to battery A with M6 screws.

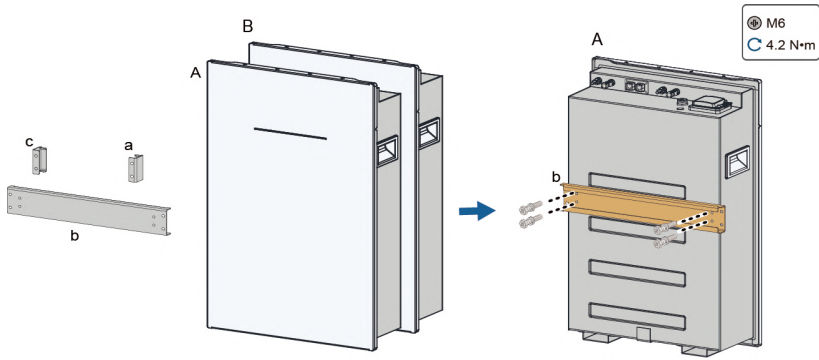

step 3 Position batteries A and B to face the same direction. Align the screw holes on one side of bracket a with those on bracket b, and secure the other side of bracket a to the front cover of battery B.

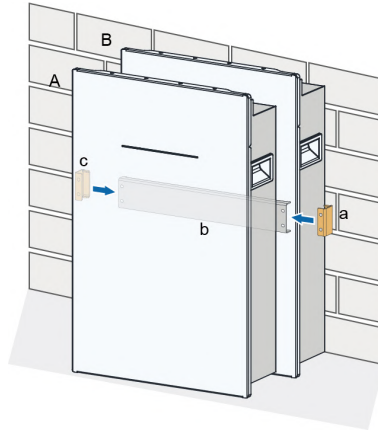

step 4 Secure brackets a and b together using screws. Then, secure bracket c on the other side of bracket b in the same way.

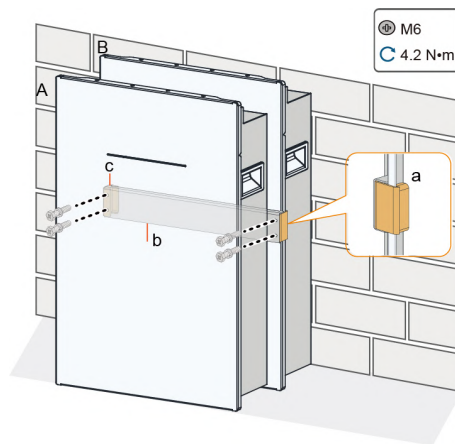

-- End

5 Electrical Connection

5.1 Safety Instructions

DANGER

- Operators must wear proper personal protective equipment during electrical connections.
- Confirm that the cables are voltage-free using a measuring instrument before touching DC cables.
- Ensure that the battery is not damaged and all cables are voltage-free before performing electrical work.
- The battery delivers electric power. Short-circuit or improper installation of the battery may result in burns or fires.

WARNING

Damage to the product caused by incorrect wiring is not covered by the warranty.

- Electrical connection must be performed by qualified personnel.
- All cables used in the system must be firmly attached, properly insulated, and adequately dimensioned.

NOTICE

All electrical connections must comply with local and national/regional electrical standards.

- All unused terminals must be closed off using waterproof caps. Failure to do so may compromise the product's ingress protection performance.
- When laying communication cables, separate them from power cables and keep them away from strong interference sources to prevent communication interruptions.
- Cables used should comply with the requirements of local laws and regulations.
- The cable colors in figures in this manual are for reference only. Please select cables according to local cable standards.

5.2 Terminal Description

Electrical terminals are set on the top of the battery, as shown below.

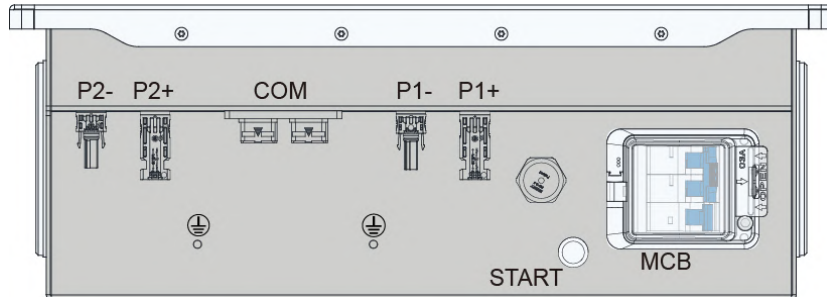



figure 5-1 Electrical Terminals

*The images shown are for illustration purposes only and may not be an exact representation of the actual product.

Name	Label	Note
Battery DC input terminal	P1+/P1-/P2+/P2-	P1+/P2+: Connected to the positive terminal of the hybrid inverter or that of the battery added for capacity expansion (battery cascading) P1-/P2-: Connected to the negative terminal of the hybrid inverter or that of the battery added for capacity expansion (battery cascading)
Communications terminal	COM	Communication port; connected to the hybrid inverter or the battery added for capacity expansion (battery cascading)
Protective grounding (PE) terminal		Used for reliable grounding of the battery
DC circuit breaker	MCB	Used to turn on/off the battery, as well as provide short-circuit protection, by breaking or closing the DC circuit
Black start button	START	Used for the black start of the battery

5.3 Electrical Connection Overview

The electrical connection between the battery and the inverter is illustrated in the figure below.

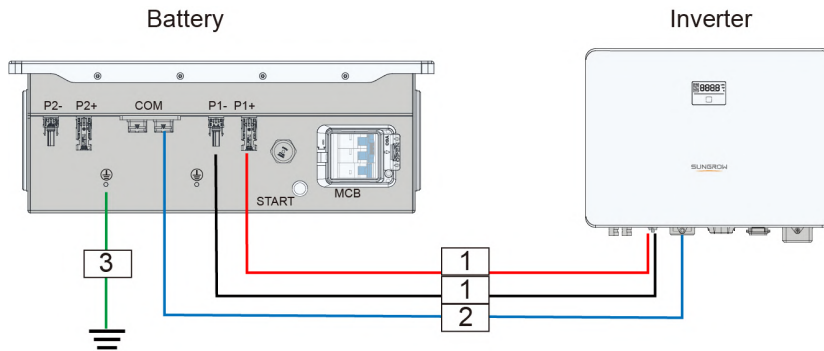

figure 5-2 Diagram of Electrical Connection Between the Battery and the Inverter

table 5-1 Cable Requirements

No.	Name	Type	Specification	
			Outer diameter	Cross-sectional area of conductor
1	DC cable	Multi-core PV cable, able to withstand voltages of >1100V	6.5mm–7.5mm	8AWG/10mm ²
2	Communication cable (included in the scope of delivery)	/	/	/
3	PE (protective grounding) cable	Outdoor multi-core copper-conductor cable, able to withstand a voltage of 1000V and work at the temperature of 105°C	6.5mm–7.5mm	8AWG/10mm ²



Secure the PE cable and the communication cable near the battery respectively using cable ties (do not bind the power cable and communication cable together). This restricts the cable movement and reduces the risk of water flowing into the battery along the cables.

5.4 PE Cable Connection

Connecting the PE cable

The PE cable should be prepared by the user separately.

1. Crimp the OT terminal onto the cable.

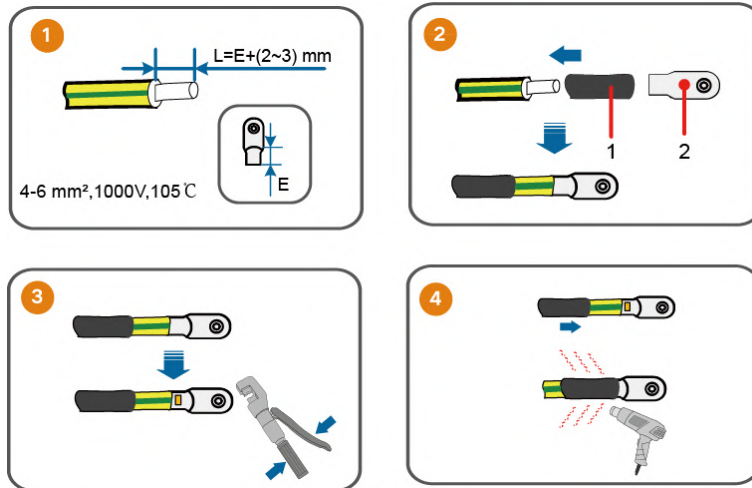

(1) Heat shrink tubing

(2) OT terminal

2. Secure the cable to the PE terminal with the screw using a screwdriver.

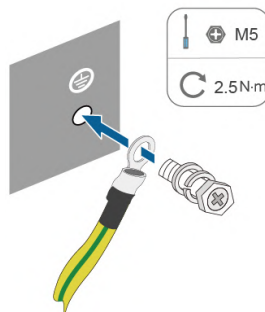

3. Apply silicone or protective paint to the PE terminal for corrosion protection.

Disconnecting the PE cable

Remove the screw from the PE terminal, and move the cable away.

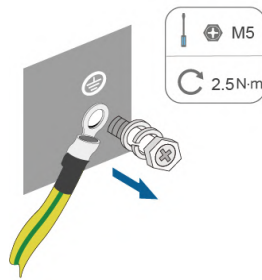

5.5 DC Cable Connection

5.5.1 Assembling the DC Connectors



The connector type is subject to the actual received device.

step 1 Strip the insulation layers from the DC cables by 15mm.

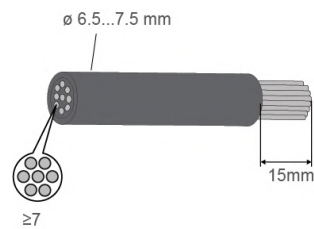

step 2 Crimp the metal crimp contacts onto the stripped cables using the crimping tool.

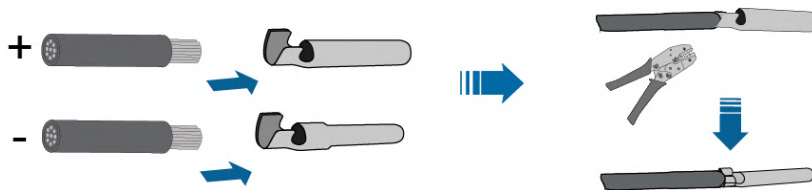

step 3 Lead the cable through the cable gland, and insert the crimp contact into the insulator until it snaps into place. Gently pull the cable backward to ensure the connection is secure.

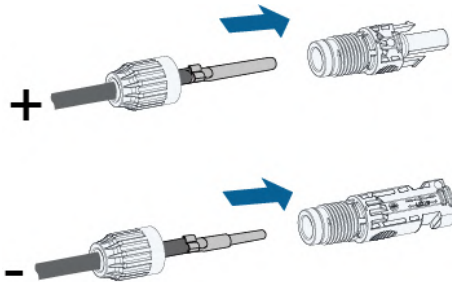

step 4 Tighten the cable gland and the insulator.

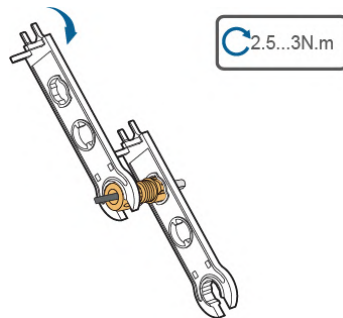

step 5 Check for polarity correctness.

-- End

5.5.2 Installing the DC Connectors

NOTICE

When making the connections, always observe the specifications regarding nominal voltage and nominal current. The smallest common value is permissible.

step 1 Remove the waterproof plugs from the DC terminals of the battery.

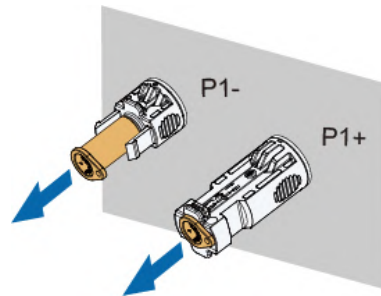

step 2 Insert the connectors into P1+ and P1- terminals, and make sure they "click" into place.

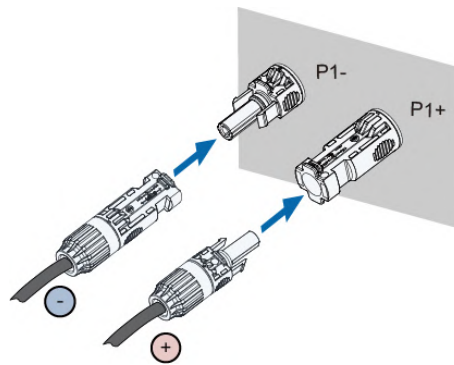

The electrical characteristics of P1+/P1- and P2+/P2- are the same. Either pair can be selected for connection.

step 3 Pull gently the DC cables backward to ensure the connection is secure.

-- End

5.6 Communication Cable Connection

5.6.1 Assembling the Communication Connectors

step 1 (Optional) Strip the insulation layer of the communication cable using Ethernet wire strippers, and lead the signal wires out. Insert the wires into the RJ45 plug in the correct order, and crimp the plug using a crimping tool.

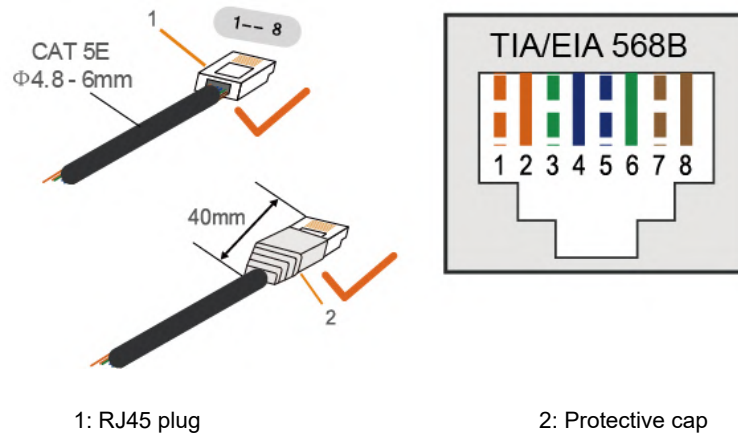

Skip this step if a standard network cable with RJ45 plug is prepared.

step 2 Remove the cable gland from the connector.

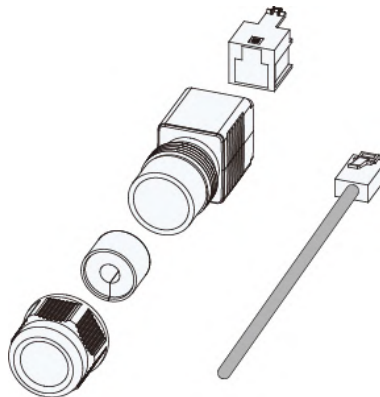

step 3 Pass the crimped RJ45 plug through the cable gland and the connector housing.

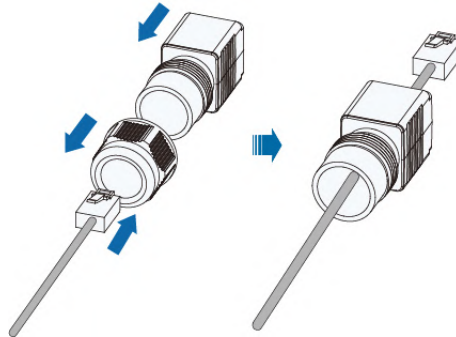

step 4 Attach the adapter to the RJ45 plug. Then, load the adapter and RJ45 plug assembly into the connector housing.

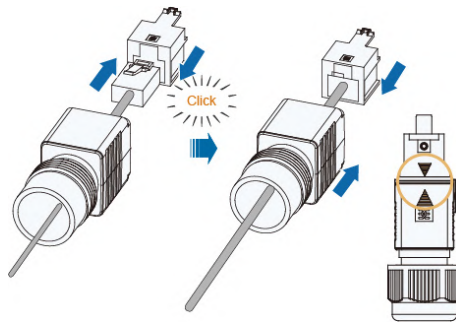

step 5 Fit the seal and the cable gland.

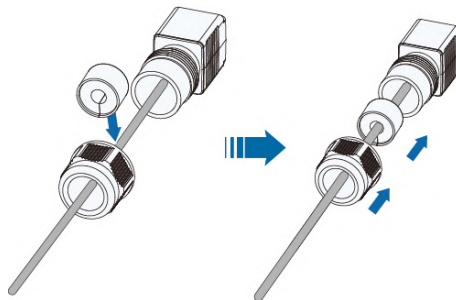

step 6 Tighten the connector at the specified torque.

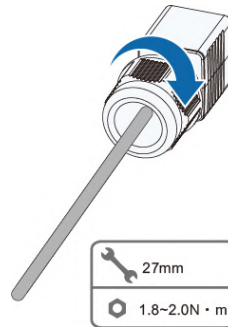

step 7 Pull gently backward the cable to ensure the connection is secure.

-- End

5.6.2 Installing the Communication Connectors

step 1 Connect the communication connector to the COM port.

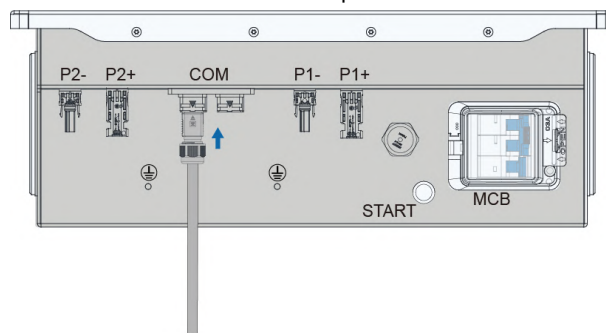

The characteristics of two COM ports are the same. Either one of them can be selected for connection.

step 2 Gently shake the connector by hand to ensure the connection is secure.

-- End

5.7 Matching Resistor Connection

5.7.1 Assembling the Matching Resistor

step 1 Assemble the stopper, gland, seal, and connector housing together in the correct order.

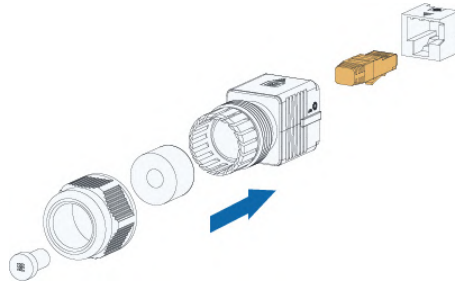

step 2 Tighten the connector housing assembly at the specified torque.

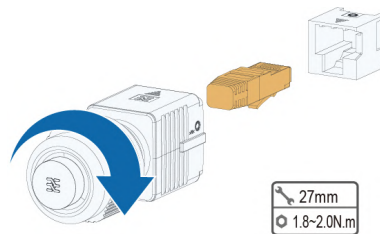

step 3 Attach the matching resistor to the adapter.

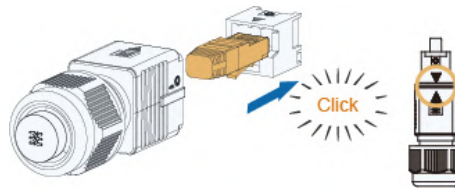

step 4 Load the adapter and resistor assembly into the connector housing.

-- End

5.7.2 Installing the Matching Resistor

step 1 Connect the matching resistor to the COM port.

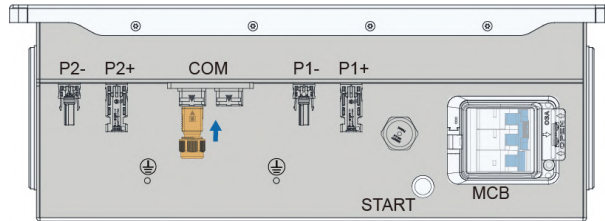

The characteristics of two COM ports are the same. Either one of them can be selected for connection.

step 2 Gently shake the connector by hand to ensure the connection is secure.

-- End

5.8 Battery Cascading



Batteries can be connected in parallel for capacity expansion (battery cascading). Typically, 2 to 4 batteries can be cascaded. Ensure the usable energy of each battery is the same before proceeding with cascading connection.

5.8.1 Side-by-Side Arrangement

In side-by-side arrangements, 2–4 batteries can be connected in parallel for capacity expansion. Below is a wiring diagram of the configuration with four parallel side-by-side batteries.

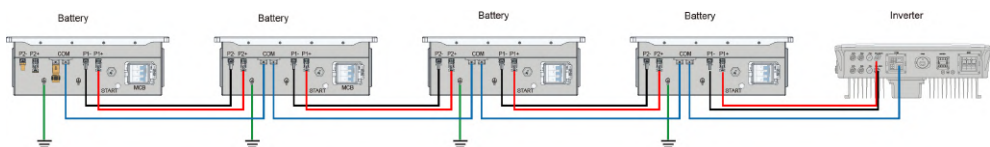

figure 5-3 Side-by-Side Battery Arrangement



Seal the unused DC input terminals on the battery with waterproof plugs.

5.8.2 Front-to-Back Arrangement

In front-to-back arrangements, a maximum of two batteries can be connected in parallel for capacity expansion.

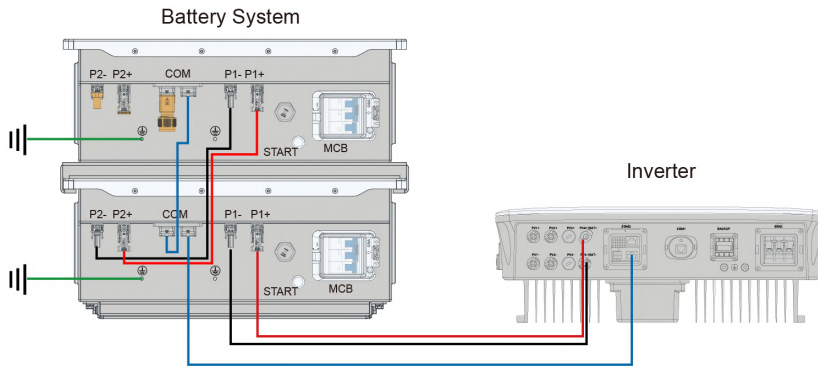

figure 5-4 Front-to-Back Battery Arrangement



Seal the unused DC input terminals on the battery with waterproof plugs.

6 Commissioning/Start-up

6.1 Inspection before Commissioning

Check the following items before starting the battery:

- Check that the battery is installed completely.
- Check that the appearance of the battery is intact.
- Check that the battery system output cables are correctly connected to the positive and negative terminals of the battery and hybrid inverter. Avoid misconnection and reverse connection.

6.2 Commissioning Procedure

If the requirements of the inspection items above are all met, please proceed with the following steps to start the battery for the first time.

Open the protective cover of the DC circuit breaker, and pull the switch up. The status indicator then blinks blue (at an interval of 1s). When the status indicator turns steady blue, it indicates that the battery is powered on and works normally.

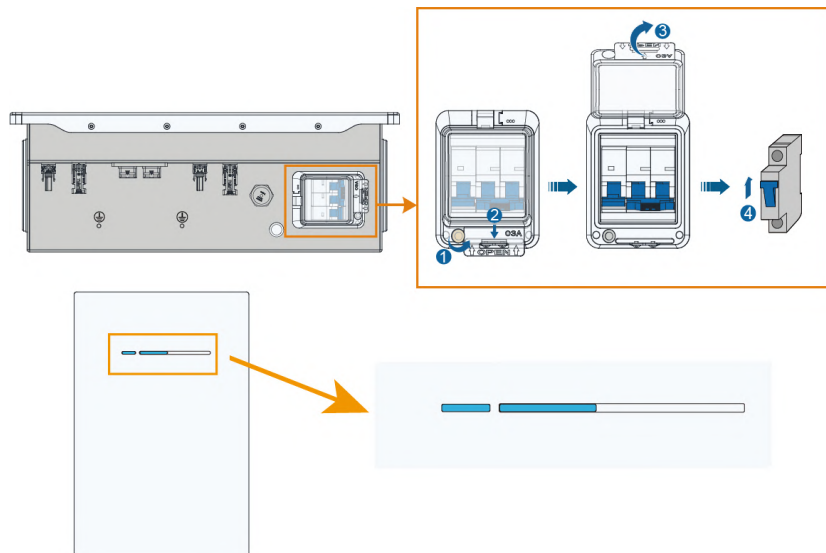

figure 6-1 Commissioning Procedure

Please refer to [2.4 LED Indicator](#) for the description of LED indicator status.



It is required to press the black start button at the first start-up of the system.

After the battery is started, close the cover of the DC circuit breaker by following the steps below. Failing to do so may expose the device to damage from adverse weather conditions, such as rain.

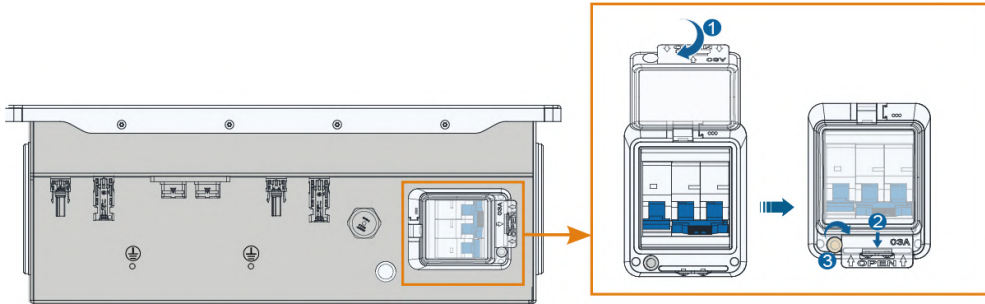

7 Decommissioning/Shutdown

The battery in the system should be decommissioned once the hybrid inverter is out of service. Proceed with the following steps to decommission the battery.

step 1 Turn off the DC circuit breaker of the battery.

step 2 One minute after the DC circuit breaker is turned off, disconnect and remove the power cables and communication cable.

-- End



Contact SUNGROW for battery disposal.

8 Viewing Battery Information

NOTICE

To view the battery information, you need to create a plant in iSolarCloud first. For detailed instructions on how to create a plant in iSolarCloud, please refer to *iSolarCloud App User Manual*. You can get the manual by scanning the QR code below.



Viewing Battery information on iSolarCloud App

1. Log in to the iSolarCloud App, and then tap **Overview**. You can check the PV energy charged into the battery on the screen.

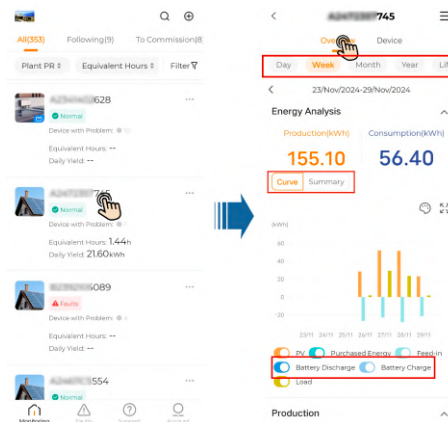

2. Choose **Device**→**Battery** to view the battery information.

Device information: Shows the basic information about the battery.

Other information: Shows the basic operating parameters of the battery.

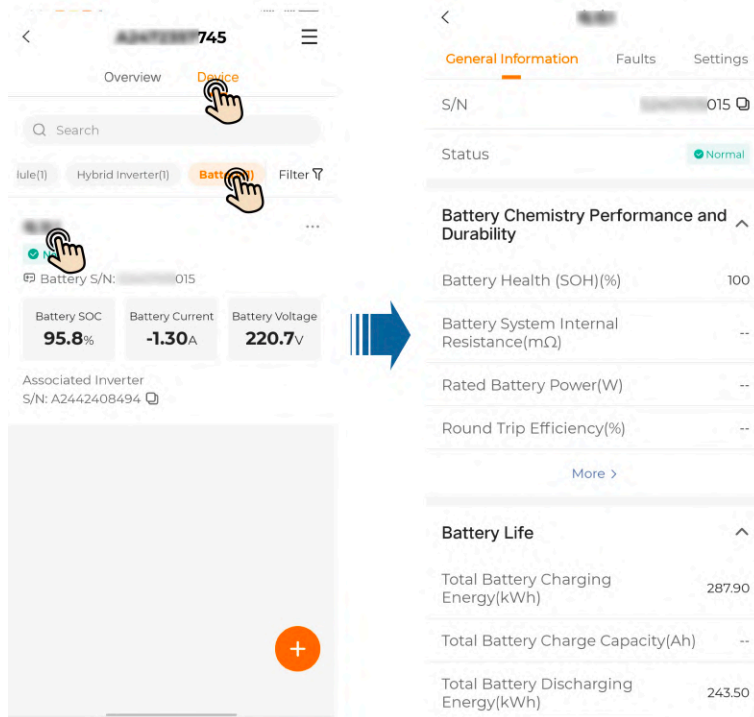

Viewing Battery information on iSolarCloud Web

1. Log in to the iSolarCloud Web, and then click **Overview**. You can check the PV energy charged into the battery on the screen.

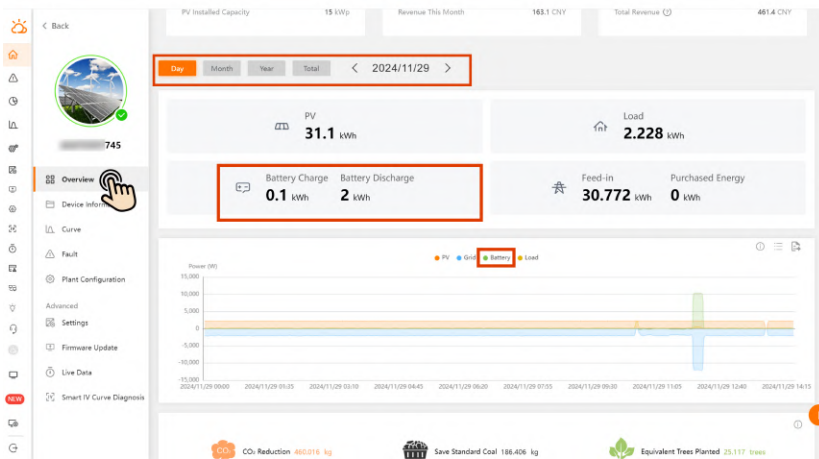
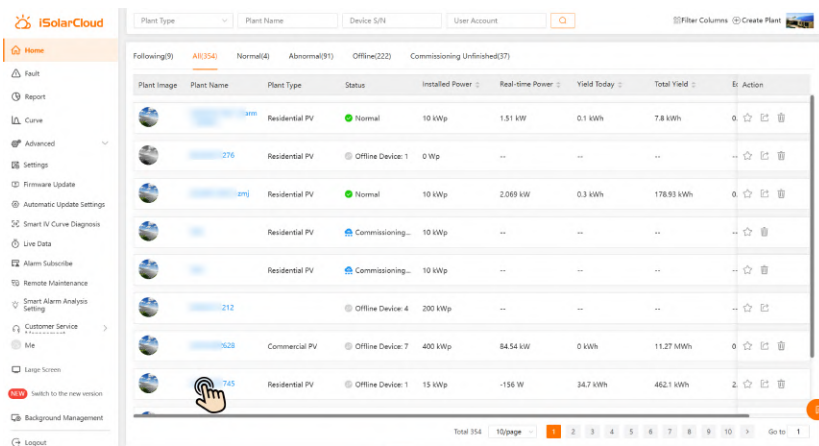

2. Choose **Device**→**Battery** to view the battery information.

Device information: Shows the basic information about the battery.

Other information: Shows the basic operating parameters of the battery.

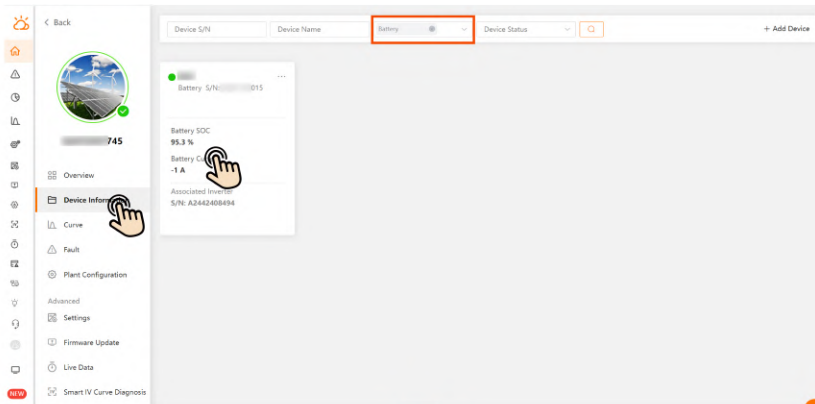

Plant Name: 745 Device Location: Device Model: SBH150-V11

General Information Pending Fault Fault History Remote Signaling Status Device Document

Measuring Point Parameter Data Update Time: 2024-11-29 16:15

Battery Information

Battery SOC	92.2 %	Battery Current	-10.3 A	Battery Voltage	223.4 V	Battery Temperature	19.1 °C
DC Contactor State	2	Fault Module ID	0	Battery Health (SOH)	100 %	Battery Operation Status	Run
Total Battery Charging Energy	289.5 kWh	Total Battery Discharging Energy	245.6 kWh				

Battery Chemistry Performance and Durability

Rated Battery Power	-- W	Round Trip Efficiency	-- %	Battery Max. Allowable Output Power	-- W	Rated Battery Capacity	-- Ah
Battery System Internal Resistance	-- mΩ						

Battery Life

Extreme Temperature Working Time	-- h	Battery Equivalent Cycles	--	Total Battery Discharge Capacity	-- Ah	Total Battery Charge Capacity	-- Ah
Deep Discharge Times	--	Extreme Temperature Charging Time	-- h				

Enabling Fast Battery Charging on iSolarCloud Web

1. Log in to the iSolarCloud Web, and then choose **Advanced**→**Settings** to view the battery parameters.

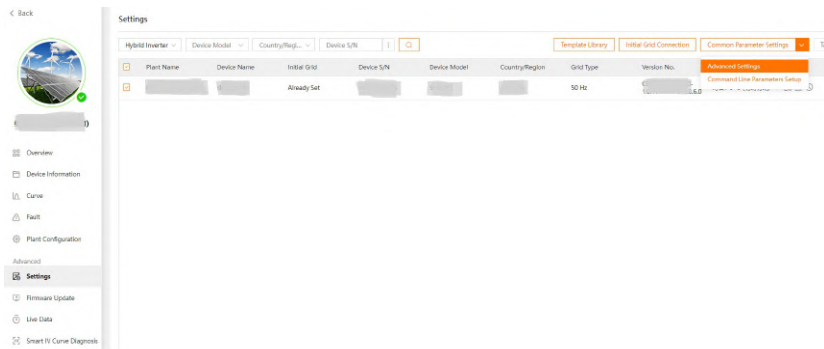

2. Choose **Power Control**→**Fast Battery Charging**, select **Enable**, and click **Apply Settings**.

The screenshot shows the 'Advanced Settings' window with the 'Power Control' tab selected. A table lists various parameters, with 'Fast Battery Charging' (No. 45) highlighted. Its 'Numerical Term' is 'Please Select', 'Degree of accuracy' is '1', and 'Unit' is '--'. A dropdown menu is open for this parameter, showing 'Please Select', 'Enable', and 'Disable' options. An 'Apply Settings' button is visible at the bottom of the table.

No.	Parameter Name	Latest Value	Numerical Term	Degree of accuracy	Unit	Remarks
33	Smooth Output		Please Select	--	--	--
34	Power Regulation at Grid Undervoltage		Please Select	--	--	--
35	MPPT Connection Mode		Please Select	--	--	--
36	Frequency Shift Power Control		Please Select	--	--	--
37	Frequency Shift Test		Please Select	--	--	--
38	Meter Reverse Connection Correction		Please Select	--	--	--
39	Import Power Limit			0.01	kW	0.01-50
40	Control Phase Selection		Please Select	--	--	--
41	Backup Voltage			0.1	V	154-276
42	Backup N-line to Ground Detection		Please Select	--	--	--
43	Offgrid Emergency Charging		Please Select	--	--	--
44	Target SOC of Offgrid Emergency Charging			1	%	1-100
45	Fast Battery Charging		Please Select	1	--	--



Please contact SUNGROW for an account and password to complete the settings.

WARNING

If fast charging is enabled, in the event of continuous charging/discharging at full power, a power derate will occur in the system once the battery temperature exceeds 50°C.

9 Battery Augmentation



If you have requirements of battery augmentation, please contact battery installers for professional support.

Battery charging and discharging may take a long time. So before adding a new battery (module), please finish charging and discharging the battery system on site remotely. Please follow the instructions as outlined below:

Follow steps 1-6 to remotely charge and discharge the batteries at the plant site to ensure that the SOC of these batteries is consistent with that of the new modules to be added.

The following conditions must be met to use the battery augmentation function:

- The iSolarCloud App version should be V2.1.6.20230731 or later.
- The battery version should be V01 or later.
- The inverter model should be SH3.0-6.0RS-20 series and the version should be later than SUNSTONE-H_01011.01.48(LCD).

WARNING

Before adding a new battery (module), be sure to charge/discharge the on-site battery system via iSolarCloud App. After the settings are completed successfully, battery charging/discharging will start automatically, until the SOC of the battery on site is the same as that of the battery to be added. Otherwise, the battery system may not work normally after the new battery is added, and the problems arising therefrom will not be covered by warranty.

step 1 Open the iSolarCloud App and tap **Local Access** at the bottom left of the login screen.

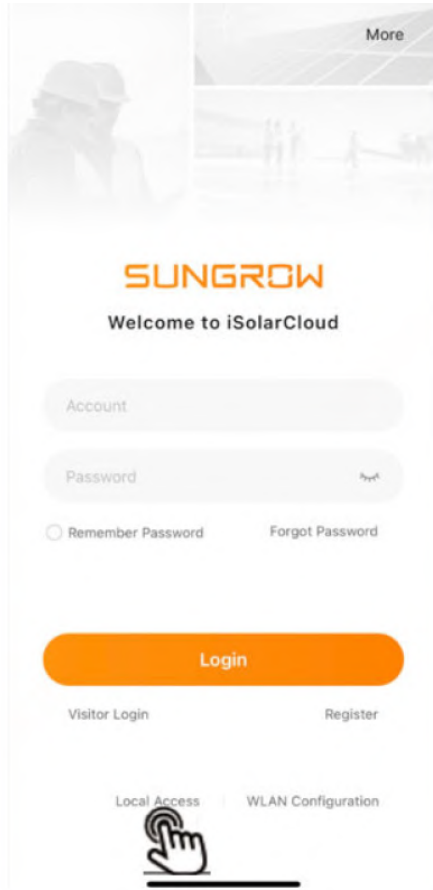

step 2 On the **Scan to Connect** screen, point your camera at the QR code on the device's enclosure, then wait for the connection to complete.

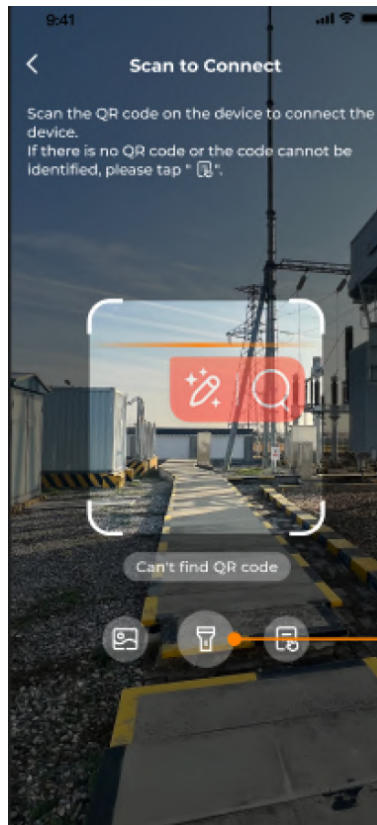

- a. If the QR code is missing or the scan fails, tap  to go to Manual Connection and connect to the device manually.

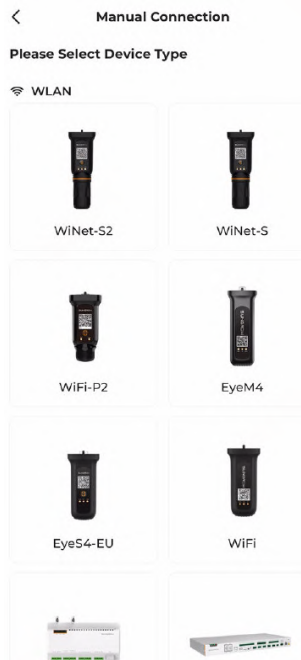

- b. Select the target device. The system will proceed to Bluetooth Connection. Wait for the connection to complete. If no Bluetooth device is found, disconnect and reconnect the communication module, then try again.

step 3 Enter your account name and password on the Identity Verification screen, and then tap Verify. The default account name and password are listed below. Please change your password as soon as possible to keep your account secure.

step 4 Navigate to **More** → **Battery Management** .

step 5 Tap **Battery Augmentation**.

step 6 Obtain the SOC of new battery modules by scanning the QR code or manually entering device

S/N. Tap  to enter the code scanning screen. Scan the QR code on the battery module to obtain the SOC.

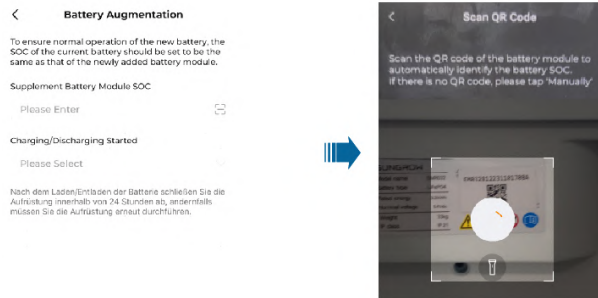

 If there is no QR code, please tap **Manually**.

step 7 Tap **Charging/Discharging Started** to set the start time, and tap **Execute Now** to wait for the charge and discharge to complete.

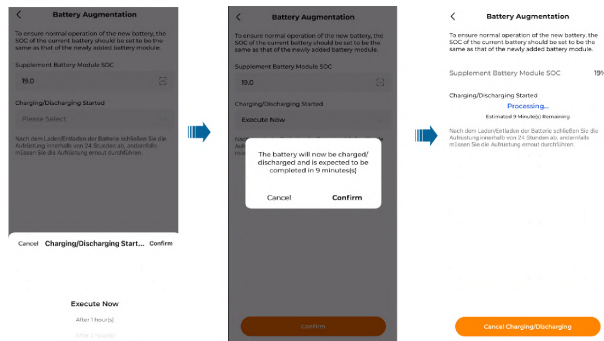

step 8 Power down the system following the commissioning steps. Install the new battery after the system is completely powered down.

step 9 Check the battery base to ensure that the battery is placed steadily after the new battery module has been added. Reactivate the battery referring to Chapter Commissioning in the battery user manual and check whether the battery operates properly. Restore the battery waterproof cover, awning (if there is), etc.

- - End

10 Troubleshooting and Maintenance

10.1 Troubleshooting

Fault Name	Fault Code	Corrective Measure
	703, 711, 712, 715, 717	<ol style="list-style-type: none"> 1. Generally, the fault will disappear by itself within 20 min. 2. In the event of continual and frequent occurrence of this fault, please switch off the battery, and contact the installer or manufacturer to check whether the inverter is damaged. 3. Please contact the installer or the manufacturer if the issue persists for a long time. Switch off the battery immediately if the SOC drops below 3% to avoid damage caused by battery over-discharge.
Battery fault	707, 733	<ol style="list-style-type: none"> 1. Check whether there is a heat source near the battery, and measure the ambient temperature. The operating temperature range of the battery is 0 to 55°C for charging, and -20 to 55°C for discharging. Please check whether the ambient temperature or the battery temperature goes beyond this range. In case the battery is placed near a heat source or in an unventilated environment, or the ambient temperature is too high, please improve the installation environment for the battery. 2. Please contact the installer or the manufacturer if the issue persists for a long time. Switch off the battery immediately if the SOC drops below 3% to avoid damage caused by battery over-discharge.
	708, 734	<ol style="list-style-type: none"> 1. The operating temperature range of the battery is 0 to 55°C for charging, and -20 to 55°C for discharging. Please check whether the ambient temperature or the battery temperature falls below this range. In case the ambient temperature is too low, please improve the installation environment for the battery. 2. Please contact the installer or the manufacturer if the issue persists for a long time. Switch off the battery immediately if the SOC drops below 3% to avoid damage caused by battery over-discharge.

Fault Name	Fault Code	Corrective Measure
	714	<ol style="list-style-type: none"> 1. Check whether the communication cable between the battery and the inverter is incorrectly or loosely connected. 2. Replace the communication cable if the problem is not resolved. 3. Please contact the installer or the manufacturer if the issue persists for a long time. Switch off the battery immediately if the SOC drops below 3% to avoid damage caused by battery over-discharge.
	732	<ol style="list-style-type: none"> 1. Please contact the installer or manufacturer to update the hybrid inverter, WiNet, and battery software to the latest version. 2. Please contact the installer or the manufacturer if the issue persists for a long time. Switch off the battery immediately if the SOC drops below 3% to avoid damage caused by battery over-discharge.
	735, 736, 737	<ol style="list-style-type: none"> 1. Generally, the battery will return to normal automatically; 2. If the problem is not resolved, switch off the battery, and restart it after 5 minutes. 3. Please contact the installer or the manufacturer if the issue persists for a long time. Switch off the battery immediately if the SOC drops below 3% to avoid damage caused by battery over-discharge.
	739	<ol style="list-style-type: none"> 1. Switch off the battery, and restart it after 5 minutes. 2. Please contact the installer or the manufacturer if the issue persists for a long time. Switch off the battery immediately if the SOC drops below 3% to avoid damage caused by battery over-discharge.
	740	<ol style="list-style-type: none"> 1. Check whether the client battery is incorrectly or loosely connected. Switch off the battery, and restart it after 5 minutes. 2. Please contact the installer or the manufacturer if the issue persists for a long time. Switch off the battery immediately if the SOC drops below 3% to avoid damage caused by battery over-discharge.

Fault Name	Fault Code	Corrective Measure
	741	<ol style="list-style-type: none"> 1. Please contact the installer or manufacturer to update the hybrid inverter, WiNet, and battery software to the latest version. 2. If the problem is not resolved, please check whether the system configuration is correct. 3. Please contact the installer or the manufacturer if the issue persists for a long time. Switch off the battery immediately if the SOC drops below 3% to avoid damage caused by battery over-discharge.
	742	<ol style="list-style-type: none"> 1. Check whether the power cables are connected in reverse or poorly connected. 2. Please contact the installer or the manufacturer if the issue persists for a long time. Switch off the battery immediately if the SOC drops below 3% to avoid damage caused by battery over-discharge.
	743, 744, 745	<ol style="list-style-type: none"> 1. Generally, the battery will return to normal automatically; 2. If the problem is not resolved, please update the battery software. 3. Please contact the installer or the manufacturer if the issue persists for a long time. Switch off the battery immediately if the SOC drops below 3% to avoid damage caused by battery over-discharge.
	746	<ol style="list-style-type: none"> 1. Please contact the installer or manufacturer to update the hybrid inverter, WiNet, and battery software to the latest version. 2. If the problem is not resolved, please contact the installer to change the order of PACKs and re-install the battery system. 3. Please contact the installer or the manufacturer if the issue persists for a long time. Switch off the battery immediately if the SOC drops below 3% to avoid damage caused by battery over-discharge.

Fault Name	Fault Code	Corrective Measure
	747	<ol style="list-style-type: none"> 1. Switch off the battery, and restart it after 5 minutes. 2. If the problem is not resolved, please update the battery software. 3. Please contact the installer or the manufacturer if the issue persists for a long time. Switch off the battery immediately if the SOC drops below 3% to avoid damage caused by battery over-discharge.
	833	<ol style="list-style-type: none"> 1. Please contact the installer or manufacturer to update the hybrid inverter, WiNet, and battery software to the latest version. 2. If the problem is not resolved, please check whether the system configuration is correct. 3. If the problem is not resolved, please contact the installer to change the order of PACKs and re-install the battery system. 4. Please contact the installer or the manufacturer if the issue persists for a long time. Switch off the battery immediately if the SOC drops below 3% to avoid damage caused by battery over-discharge.
Battery alarm	932, 939, 964	<ol style="list-style-type: none"> 1. Generally, the battery will return to normal automatically. 2. Please contact the installer or the manufacturer if the issue remains unresolved for a long term. Turn off the battery immediately if the SOC drops below 3% to avoid damage caused by battery over-discharge.
Battery alarm	937, 941, 942	<ol style="list-style-type: none"> 1. Generally, the battery will return to normal automatically. 2. If the problem is not resolved, please update the battery software. 3. Please contact the installer or the manufacturer if the issue remains unresolved for a long term. Turn off the battery immediately if the SOC drops below 3% to avoid damage caused by battery over-discharge.

Fault Name	Fault Code	Corrective Measure
	933	<ol style="list-style-type: none"> 1. Check whether there is a heat source near the battery, and measure the ambient temperature. The operating temperature range of the battery is 0 to 55°C for charging, and -20 to 55°C for discharging. Please check whether the ambient temperature or the battery temperature goes beyond this range. In case the battery is placed near a heat source or in an unventilated environment, or the ambient temperature is too high, please improve the installation environment for the battery. 2. Please contact the installer or the manufacturer if the issue persists for a long time. Switch off the battery immediately if the SOC drops below 3% to avoid damage caused by battery over-discharge.
	934	<ol style="list-style-type: none"> 1. The operating temperature range of the battery is 0 to 55°C for charging, and -20 to 55°C for discharging. Please check whether the ambient temperature or the battery temperature falls below this range. In case the ambient temperature is too low, please improve the installation environment for the battery. 2. Please contact the installer or the manufacturer if the issue persists for a long time. Switch off the battery immediately if the SOC drops below 3% to avoid damage caused by battery over-discharge.
	935	<ol style="list-style-type: none"> 1. Generally, the battery will return to normal automatically. 2. If the problem is not resolved, switch off the battery, and restart it after 5 minutes. 3. Please contact the installer or the manufacturer if the issue remains unresolved for a long term. Turn off the battery immediately if the SOC drops below 3% to avoid damage caused by battery over-discharge.

10.2 Maintenance

NOTICE

Please contact SUNGROW when adding any new battery for capacity expansion, and perform the operation following the instructions provided by SUNGROW. Otherwise, the system performance may be affected, and the system may not be able to work normally.

The recommended maintenance intervals are listed as follows, which however should be adjusted according to the actual installation environment.

The maintenance interval of the product is subject to factors such as power plant size, location, and site conditions. It is necessary to shorten the interval and increase the frequency of maintenance for products working in sandy or dusty environments.

Items to be inspected once a year

Inspection item	Inspection method
Battery status and cleanliness	<p>The following items should be inspected. Take corrective actions immediately for items that fail the inspection:</p> <ul style="list-style-type: none"> • Check if there is any damage to or deformation of the battery and its internal components. • Check if the internal components make abnormal noises during running. • Check if the temperature inside the battery goes too high.
Warning signs	Check if warning labels and signs are legible and clean. Clean them if necessary.
Cable	Check if the cables are correctly connected to the hybrid inverter.
Corrosion	Check if the battery has oxidized or rusted inside.

Items to be inspected every six months

Inspection item	Inspection method
Battery	<p>The following items should be inspected. Take corrective actions immediately for items that fail the inspection:</p> <ul style="list-style-type: none"> • Check if there are flammables near the battery. • Check if the battery is firmly fixed on the wall, and if the fixing points are rusted or corroded.
Wiring and cable laying	<p>Perform inspections only after confirming that the components inside the battery are all voltage-free. Take corrective actions immediately for items that fail the inspection during the inspection process</p> <ul style="list-style-type: none"> • Check if the cables are laid in compliance with relevant standards without short-circuit. Take corrective actions immediately for anything abnormal. • Check if water has penetrated into the battery. • Check if the cable is loosely connected. If so, fasten it at the required torque.
Grounding	Check if the system is correctly grounded.
Functions	Check if the current, voltage, and temperature of the battery are in the normal range.

NOTICE

Battery capacity auto-calibration is available only when SUNGROW hybrid inverters are used.

11 Appendix

11.1 Technical Data

table 11-1 Technical Data of high voltage LFP battery SBS050.

Type	SBS050
System Data	
Battery type	LiFePO4 Prismatic Cell
Battery module	5.12 kWh
Nominal voltage	102.4 V
Operating voltage	86.4 V to 116.8 V
Rated charging/disc harging current: continuous	30 A (charging) / 50 A (discharging)
Max. charging/disc harging current	50 A (charging) / 50 A (discharging)
Display	SOC indicator, status indicator
Communication interface	CAN
Protection	
Over-/under-voltage protection	Yes
Overcurrent protection	Yes
Over-/under-temperature protection	Yes
DC breaker	Yes
General Data	

Type	SBS050
Dimensions (W*H*D)	515±10mm*780±10mm*182±5mm
Weight	58±2 kg
Installation location	Indoor / Outdoor
Mounting method	Floor stand
Operating temperature	Charge: 0 to 55°C Discharge: -20 to 55°C
Ingress protection	IP65
Overvoltage category	II
Pollution degree	II
Allowable relative humidity range	0% to 95%, non condensing
Max. operating altitude	Max. 2000 m
Cooling method	Natural convection
Certificates	UN 38.3, IEC
Warranty ¹	10 years

Refer to battery warranty letter for conditional application.

11.2 FAQs

11.2.1 Battery Not Charging

1. Please wait 5–10 minutes for data refresh of iSolarCloud App.
2. If the problem persists, try charging the battery by enabling force mode. If the battery can be charged now, please contact the hybrid inverter installer or manufacturer.

3. Check if the current battery SOC is the same as the SOC upper limit set in hybrid inverter parameters. Once the battery SOC reaches or goes beyond the SOC upper limit, the battery cannot be charged (please set the value to 50–100 as needed).
4. If the problem is still not resolved, please check the system for any faults and take countermeasures according to the fault code.
5. If the problem is still not resolved, check whether the ambient temperature is near or below 0°C. Switch off the battery in the event of the temperature falling below 0°C, and restart and charge it when the temperature rises above 5°C.
6. If the problem persists, check whether there is a heat source near the battery and whether the ambient temperature goes higher than 55°C. Switch off the battery in the event of the temperature exceeding 55°C, and restart and charge it when the temperature falls below 40°C.
7. Contact the installer or manufacturer if the problem can still not be resolved. Switch off the battery immediately once the SOC drops below 3%.

11.2.2 Battery Not Discharging

1. Please wait 5–10 minutes for data refresh of iSolarCloud App.
2. If the problem persists, try discharging the battery by enabling force mode. If the battery can discharge now, please contact the hybrid inverter installer or manufacturer.
3. Check if the current battery SOC is the same as the SOC lower limit set in hybrid inverter parameters. Once the battery SOC reaches or falls below the SOC lower limit, the battery will not discharge (please set the value to 5–50 as needed).
4. If the problem is still not resolved, please check the system for any faults and take countermeasures according to the fault code.
5. Check whether there is a heat source near the battery and whether the ambient temperature goes higher than 55°C. Switch off the battery in the case of the temperature exceeding 55°C, and restart and discharge it when the temperature falls below 40°C.
6. Contact the installer or manufacturer if the problem can still not be resolved. Switch off the battery immediately once the SOC drops below 3%.

11.2.3 SOC Jump

1. Occasional occurrence of SOC jump is normal and does not compromise the normal operation of the system.

2. In case the SOC jump issue occurs frequently, please contact the installer or manufacturer.

11.2.4 Battery Update

1. Please contact the installer or manufacturer for iSolarCloud update if needed.
2. If the iSolarCloud is updated, please update the software of the hybrid inverter, the communication module, and the battery at the same time. Otherwise, there may be problems arising from the mismatch of software versions.
3. Please contact the installer or manufacturer immediately in case of anything abnormal during or after the update.

11.3 Quality Assurance

When product faults occur during the warranty period, SUNGROW will provide free service or replace the product with a new one.

Evidence

During the warranty period, the customer shall provide the product purchase invoice and date. In addition, the trademark on the product shall be undamaged and legible. Otherwise, SUNGROW has the right to refuse to honor the quality guarantee.

Conditions

- After replacement, unqualified products shall be processed by SUNGROW.
- The customer shall give SUNGROW a reasonable period to repair the faulty device.

Exclusion of Liability

In the following circumstances, SUNGROW has the right to refuse to honor the quality guarantee:

- The free warranty period for the whole machine/components has expired.
- The device is damaged during transport.
- The device is incorrectly installed, refitted, or used.
- The device operates in harsh conditions beyond those described in this manual.
- The fault or damage is caused by installation, repairs, modification, or disassembly performed by a service provider or personnel not from SUNGROW.
- The fault or damage is caused by the use of non-standard or non-SUNGROW components or software.

- The installation and use range are beyond stipulations of relevant international standards.
- The damage is caused by unexpected natural factors.

For faulty products in any of above cases, if the customer requests maintenance, paid maintenance service may be provided based on the judgment of SUNGROW.



Product data such as product dimensions are subject to change without prior notice. The latest documentation from SUNGROW should take precedence in case of any deviation.

11.4 Contact Information

In case of questions about this product, please contact us. We need the following information to provide you the best assistance:

- Model of the device
- Serial number of the device
- Fault code/name
- Brief description of the problem

For detailed contact information, please visit: <https://en.SUNGROWpower.com/contactUS>

SUNGROW

Sungrow Power Supply Co., Ltd.
www.sungrowpower.com