

Ecoflow PowerOcean Hybrid Inverter

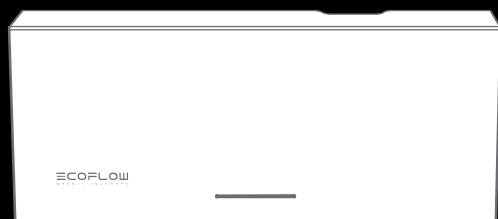

CHANGE HISTORY

Changes between document issues are cumulative. The latest document issue contains all the changes made in earlier issues.

Issue 1.1 (2024-06-12)

- Updated the METER communication terminal of the equipment.

Issue 1.0 (2024-03-07)

- This issue is the first official release.

CONTENTS

1	Safety Instructions
1	Disclaimer
1	Statement
1	Symbol Conventions
1	General Requirements
1	Personnel Requirements
1	Electrical Safety
2	Installation Environment Requirements
2	Equipment and personnel safety requirements
2	Grounding conductor monitoring
2	Declaration of the Rated Residual Current of the Residual Current Device
3	Checking before Installation
3	Checking Outer Packing
3	Checking Deliverables
3	Product Storage
3	Product Introduction
3	Function
3	System Overview
3	Networking Application
3	Supported Power Grid Types
4	Appearance
4	Label Description
4	Working Principles
4	System Operating Mode
4	System Installation
5	Electrical Connection
5	System Commissioning
5	System Operation
5	System Power-On
5	App Control
5	For End User
5	For Installer
6	System Maintenance
6	System Power-Off
6	Routine Maintenance
6	Troubleshooting
6	Inverter Decommissioning
6	Removing an inverter
6	Disposing an inverter
7	Technical Parameters
8	Appendix: Network security & Vulnerability Disclosure
9	EU Declaration of Conformity

Safety Instructions

DISCLAIMER

Read this user manual carefully before using the product to ensure that you completely understand the product and can correctly use it. After reading this user manual, keep it properly for future reference. Improper use of this product may cause serious injury to yourself or others, or cause product damage and property loss. Once you use this product, it is deemed that you understand, approve and accept all the terms and content in this document. EcoFlow is not liable for any loss caused by the user's failure to use this product in compliance with this user manual.

In compliance with laws and regulations, EcoFlow reserves the right to final interpretation of this document and all documents related to this product. This document is subject to changes (updates, revisions, or termination) without prior notice. Please visit EcoFlow's official website to obtain the latest product information.





STATEMENT

Follow local laws and regulations when installing, operating, or maintaining the equipment. The safety instructions in this manual are only supplements to local laws and regulations.

EcoFlow will not be liable for any consequence caused by the violation of general safety requirements or design, production, and usage safety standards.

SYMBOL CONVENTIONS

This is a safety warning symbol. Such safety information alerts you to hazards that can be lethal to you and others, and that can cause damages to the equipment. All safety information is preceded by safety warning symbols and hazard words, including: "DANGER", "WARNING", "CAUTION", and "NOTICE". The "DANGER", "WARNING", "CAUTION", and "NOTICE" statements in this manual do not cover all the safety instructions. They are only supplements to the safety instructions.

Symbol	Description
 DANGER	Indicates a hazard with a high level of risk which, if not avoided, will result in death or serious injury.
 WARNING	Indicates a hazard with a medium level of risk which, if not avoided, could result in death or serious injury.
 CAUTION	Indicates a hazard with a low level of risk which, if not avoided, could result in minor or moderate injury.
 NOTICE	Indicates a potentially hazardous situation which, if not avoided, could result in equipment damage, data loss, performance deterioration, or unanticipated results. NOTICE is used to address practices not related to personal injury.

GENERAL REQUIREMENTS

DANGER

- Do not work with power on during installation.

WARNING

- When the photovoltaic array is exposed to light, it supplies a d.c. voltage to the PCE.

CAUTION

- The product must only be operated with PV modules of protection class II in accordance with IEC 61730, application class A. The PV modules must be compatible with this product. Do not ground the PV array positive/negative hole.
- If the power cord of this equipment is damaged, it must be replaced by the manufacturer, customer service department or qualified personnel to prevent a safety hazard.
 - Do not touch the exposed cable with your hands.
 - Make sure the cables, connectors and ports are dry before starting up the equipment. Make sure all three are connected securely.
 - Do not install, use, or operate outdoor equipment and cables in harsh weather conditions such as lightning, rain, snow, and level 6 or stronger wind.
 - Tighten the screws to the specified torque using tools when installing the equipment.
 - After installing the equipment, remove the remnants of the device installation area, such as cardboard boxes, foam, plastic, wire ties, stripped insulation materials, etc.
 - All warning label and nameplates on the equipment should be visible after installation is complete. Do not scrawl, damage, or block any warning label on the device.

- Understand the components and functioning of a grid-tied PV power system and relevant local standards.
- Do not open the host panel of the equipment without permission.
- Do not reverse engineer, decompile, disassemble, adapt, add code to the device software or alter the device software in any other way. Any other operation that violates the original design specifications of the device hardware and software is not allowed.
- If there is a probability of personal injury or equipment damage during operations on the equipment, immediately stop the operations, take feasible protective measures.
- Use tools correctly to avoid hurting people or damaging the equipment.
- Do not touch the energized equipment, as the enclosure is hot.
- Use insulated tools when operating equipment and wear personal protective equipment to ensure personal safety. Wear anti-static gloves, clothing and wristbands when touching electronic devices to protect equipment from damage.
- Prior to performing any work on the equipment, always disconnect it from all voltage sources as described in this section. Always adhere to the prescribed sequence.
- Before installing PV modules, please read its user manual carefully.
- The system is not suitable for power supplying life-sustaining medical devices. It cannot guarantee backup power in all circumstances.
- Do not connect loads between the inverter and the AC switch that directly connects to the inverter.

PERSONNEL REQUIREMENTS

- Personnel who plan to install or maintain EcoFlow equipment must receive thorough training, understand all necessary safety precautions, and be able to correctly perform all operations.
- Only qualified professionals are allowed to install, operate, and maintain the equipment.
- Personnel who will operate the equipment, including operators, trained personnel, and professionals, should possess the local national required qualifications in special operations such as high-voltage operations, working at heights, and operations of special equipment.



Professionals: personnel who are trained or experienced in equipment operations and are clear of the sources and degree of various potential hazards in equipment installation, operation, and maintenance.

ELECTRICAL SAFETY

GROUNDING

- For the equipment that needs to be grounded, install the ground cable first when installing the equipment and remove the ground cable last when removing the equipment.
- Ground the PE hole of GRID & BACKUP connector and the equipment enclosure.
- Do not damage the ground conductor.
- Do not operate the equipment in the absence of a properly installed ground conductor.
- Ensure that the equipment is connected permanently to the protective ground. Before operating the equipment, check its electrical connection to ensure that it is securely grounded.

GENERAL REQUIREMENTS

DANGER

- Before connecting cables, ensure that the equipment is intact. Otherwise, electric shocks or fire may occur.

- Ensure that all electrical connections comply with local electrical standards.
- Obtain approval from the local electric utility company before using the equipment in grid-tied mode.
- Ensure that the cables installer prepared meet local regulations.
- Use dedicated insulated tools when performing high-voltage operations.
- Before connecting a power cable, check that the label on the power cable is correct. When fabricating cables and installing connectors on site, follow the respective instructions in this manual and the requirements of local laws and regulations.
- Before operating the equipment, disconnect all power to the equipment and wait for the corresponding delayed discharge time to ensure that the equipment is completely deenergized.

CABLING

- The cabling path must avoid the equipment cooling system and parts.
- When routing cables, ensure that a distance of at least 30 mm exists between the cables and heat-generating components or areas. This prevents damage to the insulation layer of the cables.
- Bind cables of the same type together. When routing cables of different types, ensure that they are at least 30 mm away from each other. Mutual entanglement or cross-deployment is not allowed.
- Ensure that the cables used in a grid-tied PV power system are properly connected and insulated and meet specifications.

INSTALLATION ENVIRONMENT REQUIREMENTS

1. Ensure that the equipment is installed in a well ventilated environment.
2. To prevent fire due to high temperature, ensure that the ventilation vents or heat dissipation system are not blocked when the equipment is under operation.
3. Do not expose the equipment to flammable or explosive gas or smoke. Do not perform any operation on the equipment in such environments.
4. Do not place the equipment next to any heat source, fire source, or water source, and not to perform any operation on the equipment next to that heat source, fire source, or water source.

EQUIPMENT AND PERSONNEL SAFETY REQUIREMENTS

MOVING THE EQUIPMENT

1. When moving the equipment by hand, wear protective gloves to prevent injuries.
2. Move the equipment with precaution as it is heavy. When two or more people are needed to assist in moving the equipment, please ensure communication and coordination between personnels to prevent being crushed or sprained.

USING TOOLS

1. Use wooden or fiberglass ladders when you need to perform live working at heights.
2. Before using a ladder, check that it is intact and confirm its load bearing capacity. Do not overload it.
3. Make sure the operator is regulated in the use of installation tools, such as ladders, electric paddles, drills, etc. Make sure the tool power cord is not tangled.
4. When installing, strictly prevent screws, nuts and spacers from falling inside the equipment and ensure that the tools (such as electric drill bit) do not fall into the gap between the installed equipment and the wall to prevent delaying the installation.

DRILLING HOLES

1. Wear goggles and protective gloves when drilling holes.
2. When drilling holes, protect the equipment from shavings or dust. After drilling, clean up any shavings or dust that have accumulated at the installation site in a timely manner, otherwise, it may block the drilled hole.

GROUNDING CONDUCTOR MONITORING

The inverter is equipped with a grounding conductor monitoring device. This grounding conductor monitoring device detects when there is no grounding conductor connected and disconnects the inverter from the utility grid if this is the case. Depending on the installation site and grid configuration, it may be advisable to disable the grounding conductor monitoring. This can be necessary, if there is no neutral conductor present and you intend to install the inverter between two line conductors.

1. Grounding conductor monitoring must be disabled after initial start-up depending on the grid configuration. Safety in accordance with IEC 62109 when the grounding conductor monitoring is deactivated. In order to guarantee safety in accordance with IEC 62109 when the grounding conductor monitoring is deactivated, you have to connect an additional grounding conductor to the inverter.
2. Connect an additional grounding conductor that has a cross-section of at least 10 mm. Ground the PE hole of GRID & BACKUP connector and the equipment enclosure.

DISPOSAL

For information on the disposal of electrical and electronic equipment, please visit the following website:
<https://eu.ecoflow.com/pages/electronic-devices-disposal>

SETTING THE RATED RESIDUAL CURRENT OF THE RESIDUAL-CURRENT DEVICE

RCD (type A) with rated residual operating current of 100 mA(AC-GRID) and 30mA (AC-BACKUP) would be recommended if there is additional protection by RCD shall be provided for local electrical installation, while the use of an RCD with lower rated residual operating current is also permitted if it is required by the specific local electrical codes. When using residual-current devices with a rated residual current of 100 mA, set the rated residual current to 100 mA.

Checking before Installation

CHECKING OUTER PACKAGING

Before unpacking the equipment, check the outer packing for damage, such as holes and cracks, and check the model. If any damage is found, do not unpack the package and contact your supplier as soon as possible.

CHECKING DELIVERABLES

After unpacking the equipment, check that the deliverables are intact and complete. If any item is missing or damaged, contact your dealer.



For details about the number of accessories delivered with the equipment, see **What's In The Box** in the Installation Guide.

Product Storage

The following requirements should be met if the equipment is not put into use directly:

1. Do not unpack the equipment.
2. Keep the storage temperature at -30°C to $+60^{\circ}\text{C}$ and the humidity at 0%–100% RH.
3. The product should be stored in a clean and dry place and be protected from dust and water vapor corrosion.
4. Do not stack the inverters to avoid personal injury or equipment damage. Do not place this product near water, fire or other heat sources (heaters, direct sunlight, gas ovens, etc.).
5. During the storage period, check the equipment periodically.
6. If the equipment has been stored for a long time (more than 6 months), it must be checked and tested by professionals before being put into use.



For details about Battery maintenance, see EcoFlow PowerOcean LFP Battery User Manual.

Product Introduction

FUNCTION

The EcoFlow PowerOcean Hybrid Inverter is a single-phase grid-tied string inverter that converts the DC power generated by PV strings into AC power and enables highly efficient solar energy usage and storage to achieve your home power independence. The inverter is integrated with backup module, offering up to 6kW output to power almost every essential appliance in case of any grid outage.

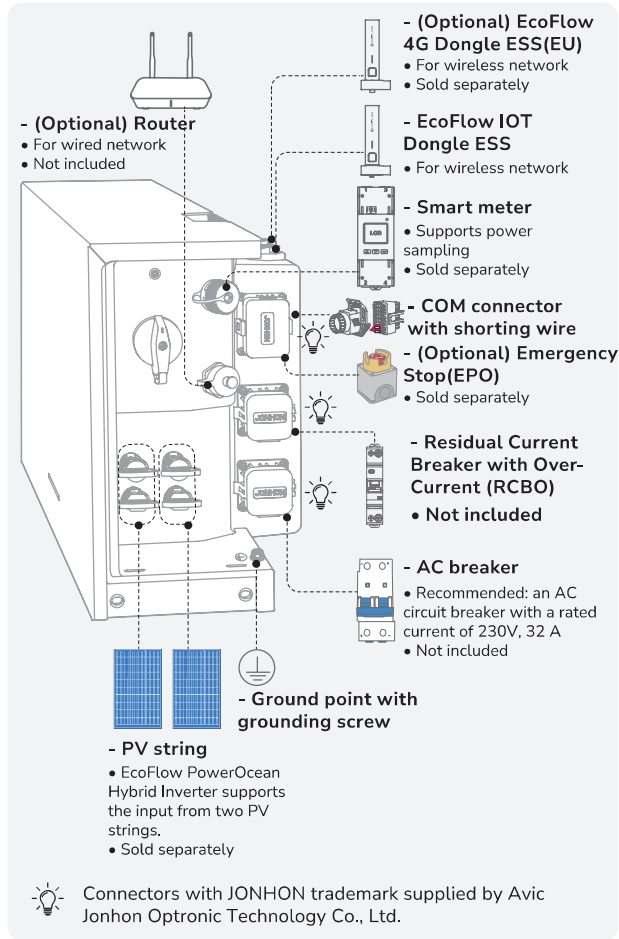

SYSTEM OVERVIEW

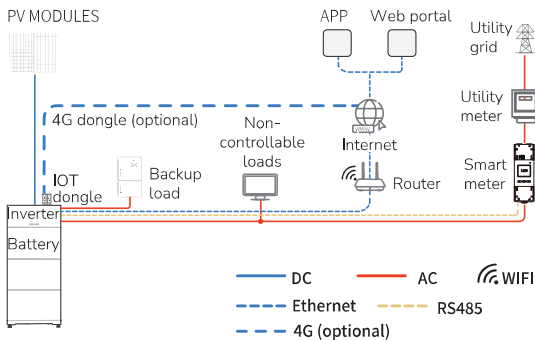

NETWORKING APPLICATION

This equipment applies to residential grid-tied systems. The system consists of PV strings, EF BD-5.1-S1 batteries, hybrid inverter, AC switches, and power distribution units.

SUPPORTED POWER GRID TYPES

The inverter supports the following power grid types: TN-S, TN-C, TN-C-S, and TT.

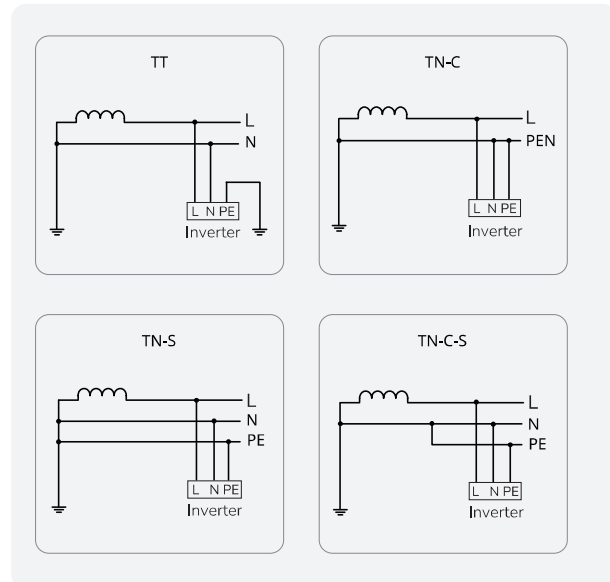

APPEARANCE

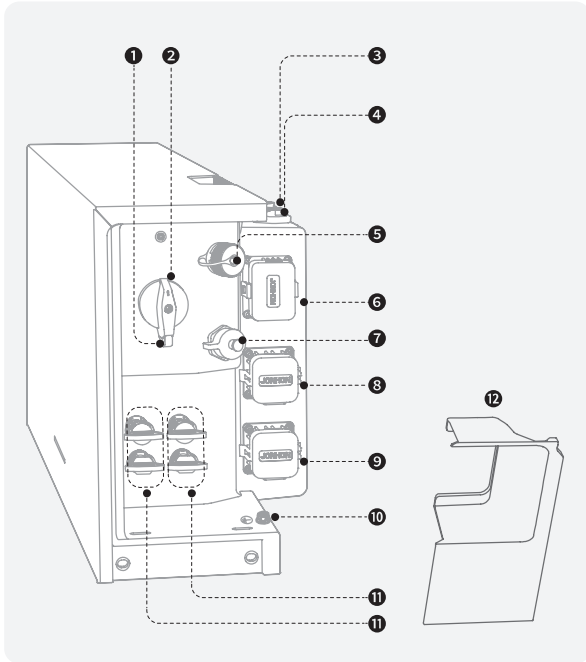

- | | |
|--|---|
| <p>① Lock hole button: Push upwards to reveal the lock hole and secure the PV switch with a lock to prevent accidental startup.</p> <p>② PV SWITCH: Control of solar PV input source only, no control of other voltage sources.</p> <p>③ 4G dongle port (USB-A)</p> <p>④ IOT dongle port (USB-C)</p> | <p>⑤ Meter communication port</p> <p>⑥ Communication port (COM)</p> <p>⑦ Ethernet port (WAN)</p> <p>⑧ Backup load port (BACKUP)</p> <p>⑨ Power grid port (GRID)</p> <p>⑩ Ground point with grounding screw</p> <p>⑪ PV input terminals (PV1+/- / PV2+/-)</p> <p>⑫ Trim cover with screw</p> |
|--|---|

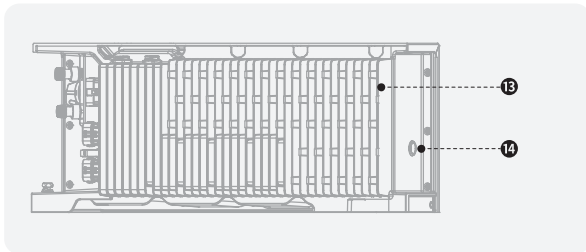

- | | |
|-------------|-------------------------|
| ⑬ Heat sink | ⑭ BATTERY ON/OFF button |
|-------------|-------------------------|

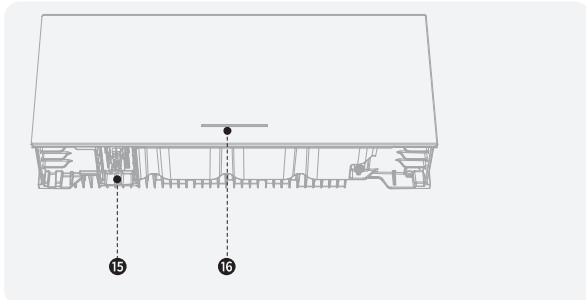

- | | |
|---------------------|-----------------|
| ⑮ Click-on terminal | ⑯ LED indicator |
|---------------------|-----------------|

LABEL DESCRIPTION

ENCLOSURE LABELS

Icon	Name	Meaning
	Electric shock warning	Caution, risk of electric shock
	Delayed discharge	Danger to life due to high voltages in the inverter; observe a waiting time of 5 minutes. High voltages that can cause lethal electric shocks are present in the live components of the inverter. Prior to performing any work on the inverter, disconnect it from all voltage sources as described in this document.
	Burn warning	Do not touch a running equipment because the enclosure is hot when the equipment is running.
	Refer to documentation	Reminds operators to refer to the documents delivered with the equipment.
	Grounding	Indicates the position for connecting the protective earthing (PE) cable.
	Operation warning	Do not remove the AC/DC connector when the equipment is running.
	Symbol of a crossed-out trash can	WEEE designation Do not dispose of the product together with the household waste but in accordance with the disposal regulations for electronic waste applicable at the installation site.
	CE marking	The product complies with the requirements of the applicable EU directives.



The labels are for reference only.

WORKING PRINCIPLES

The inverter receives inputs from up to two PV strings. Then the inputs are grouped into two MPPT routes inside the equipment to track the maximum power point of the PV strings. The DC power is then converted into single-phase AC power through an inverter circuit. Surge protection is supported on both the DC and AC sides.

System Operating Mode

SELF-POWERED MODE

- This mode applies to areas where the electricity price is high, or areas where the feed-in tariff subsidy is low or unavailable.
- Excess PV energy is stored in batteries. When PV power is insufficient or no PV power is generated at night, batteries discharge to supply power to the loads, improving the self-consumption rate of the PV system and the self-sufficiency rate of residential energy, and reducing electricity costs.
- In this mode, by default, the charge cutoff capacity is 100% and the discharge cutoff capacity is 5% for EcoFlow EF BD-5.1-S1 LFP batteries.

System Installation

For System Installation, please refer to Installation Guide delivered with the equipment.

Electrical Connection

For Electrical Connection, please refer to Installation Guide delivered with the equipment.

System Commissioning

For System Commissioning, please refer to Installation Guide delivered with the equipment.

System Operation

SYSTEM POWER-ON

PROCEDURE (ON-GRID AND PV MODULE CONFIGURED)

1. Turn on the AC switch between the inverter and the power grid.
2. Set the PV SWITCH on the side of the inverter to ON position.
3. Observe the LED to check the inverter operating status.

PROCEDURE (OFF-GRID AND NO PV MODULE CONFIGURED)

1. Turn on the AC switch between the inverter and the power grid.
2. Set the PV SWITCH on the side of the inverter to ON position.
3. After commissioning, press and hold for 5 seconds the BATTERY ON/OFF button.
4. Observe the LED to check the inverter operating status.

LED INDICATORS

LED Indicator	Symbol Conventions	
ON		Steady White
		Blinking White
		Carousel White
		Steady Orange
		Blinking Orange
OFF		OFF

Power On/Off Status	Description
	System startup
	System shutdown
Charge Status	Description
	0-25%
	25-50%
	50-75%
	75-99%
	100%
Discharge/Standby Status	Description
	<5%
	5-25%
	25-50%
	50-75%
	75-100%
Over-the-air Updates Status	Description
	Over-the-air update is in progress

Faulty Status	Description
	Abnormal electrical connection. Check if all equipment is installed correctly and securely.
	Abnormal smart meter communication.
	Abnormal IoT communication.
	Battery is faulty.
	Abnormal battery communication.
	Converter is faulty.
	Abnormal converter communication.

- NOTICE**
- If the LED indicates a faulty status, visit the EcoFlow Pro app to retrieve the error code for troubleshooting.

App Control

EcoFlow provides thorough support for the system. Both the end user and installer benefit from our comprehensive guides and resources.

FOR END USER

Effortlessly manage, monitor, and control your PowerOcean devices through a sleek, user-friendly interface via app or web management. Access real-time energy data, detailed power generation, storage and energy bills savings anytime and anywhere. Professional technical support is also readily available when needed.

EcoFlow App Management

Scan the QR code or download at <https://download.ecoflow.com/app>

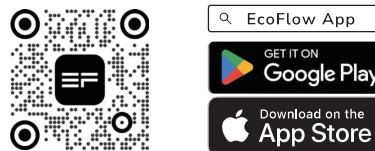

PRIVACY POLICY

By using EcoFlow Products, Applications and Services, you consent to the EcoFlow Term of Use and Privacy Policy, which you can access via the "About" section of the "User" page on the EcoFlow App or on the official EcoFlow website at <https://www.ecoflow.com/policy/terms-of-use> and <https://www.ecoflow.com/policy/privacy-policy>

FOR INSTALLER

Streamline the commissioning process, monitor device status in real-time, access detailed troubleshooting solutions for system faults and also offer customer support from EcoFlow professional support team.

EcoFlow Pro App Management

Scan the QR code or download at <https://download.ecoflow.com/ecoflowproapp>



System Maintenance

SYSTEM POWER-OFF

WARNING

- Before installing, operating, and maintaining the equipment, always disconnect it from all power.
1. Send a shutdown command on the App.
 2. Turn off the AC switch between the inverter and the power grid.
 3. Set the PV SWITCH to OFF position.
 4. (Optional) Secure the PV switch with a lock to prevent accidental startup. The lock is prepared by the customer.
 5. Press and hold the BATTERY ON/OFF button of the junction box for 10 seconds, until the indicator is off.

ROUTINE MAINTENANCE

WARNING

- Power off the inverter and follow the instructions on the delayed discharge label to ensure that the inverter is powered off.
 - Wear proper PPE before any operations.
1. Ensure that the PV SWITCH of the inverter and the AC switch between the inverter and the power grid are OFF.
 2. Place temporary warning signs or erect fences to prevent unauthorized access to the maintenance site.
 3. If the equipment is faulty, contact your dealer.
 4. The equipment can be powered on only after all faults are rectified. Failing to do so may escalate faults or damage the equipment.

Check Item	Check Method	Recommended Maintenance Interval
System cleanliness	Check periodically that the heat sinks are free from obstacles and dust. If there is any stain/dirt, use a dry, soft cloth to wipe it off and prohibit the use of stain removing powder, any liquid, coarse brush, abrasives or hard objects to clean the equipment. Ensure equipment well-ventilated.	Once every 6 months
System running status	Check that the equipment is not damaged or deformed. Check that the equipment operates with no abnormal sound. Check that all equipment parameters are correctly set during operation.	Once every 6 months
Electrical connection	Check that cables are secured. Check that cables are intact.	Once every 6 months
Grounding reliability	Check that ground cables are securely connected.	Once every 6 months
Seal ability	Check that unused terminals, ports, waterproof covers are locked as delivered.	Once every 6 months

TROUBLESHOOTING

WARNING

- Only professionals with appropriate qualifications can perform the following activities.
 - Wear proper PPE before any operations.
1. Visit and log in to the **EcoFlow Pro** app.
 2. Retrieve the error code and in-app instructions.
 3. Completely power off the entire system, see the **System Power-Off**.
 4. Follow the in-app instructions to fix the issue.



- As end users, you can visit and log in to the **EcoFlow** user app and find the most common FAQ or contact customer support by tapping the following in sequence **Setting-Help and feedback**.
- If the problem persists, contact the EcoFlow technical support team.

Inverter Decommissioning

If the inverter cannot work anymore, dispose of it according to the local disposal requirements for electrical equipment waste. The inverter cannot be disposed of together with household waste.

Hereby, our products have met the regulations of BattG in Germany.

CAUTION

- Before removing a inverter, power it off . For details, see **System Power-Off**.

REMOVING AN INVERTER

PROCEDURE

1. Sequentially disconnect GRID cables, BACKUP cables, PV input cables, communication cables and all modules connecting to the system..
2. Remove the inverter from the mounting bracket.
3. Remove the mounting bracket.
4. Pack and store the inverter properly.

DISPOSING AN INVERTER



If the inverter cannot work anymore, dispose of it according to the local disposal rules for electrical equipment waste. The inverter cannot be disposed of together with household waste.

Technical Parameters

Technical parameters		EF HD-P1-3K-S1	EF HD-P1-3.68K-S1	EF HD-P1-4.6K-S1	EF HD-P1-5K-S1	EF HD-P1-6K-S1
DC Input (PV)	Maximum PV Power (W)	9000	9680	10600	11000	12000
	Maximum Input Voltage (V)	600				
	Mppt Voltage Range (V)	90-520				
	Maximum Input Current per MPPT (A)	18 (single PV input), 16 (dual PV input)				
	Maximum Short Circuit Current per MPPT (A)	20				
	Backfeed Current to the PV Array (A)	0				
	Number of MPPTs	2				
DC Input (Battery)	Overvoltage Category	II				
	Rated Voltage (V)	790				
	Maximum Voltage (V)	800				
	Rated Current (A)	7.6				
	Maximum Current (A)	7.6	7.6	7.6	7.6	8.4
Maximum Battery Capacity (kWh)	15.3					
AC Input	Grid Connection	L+N+PE				
	Overvoltage Category	III				
	Rated Input Power (W)	3000	3680	4600	5000	6000
	Maximum Apparent Power (VA)	3000	3680	4600	5000	6000
	Rated Input Voltage (V)	220/230/240, L+N+PE				
	Maximum Input Current (A)	16	19.7	24.6	26.7	32
	Nominal Frequency (Hz)	50/60				
AC Output (On-grid)	Inrush Current (Peak Value/Duration Time) (A)	92@3μs				
	Grid Connection	L+N+PE				
	Overvoltage Category	III				
	Rated Output Power (W)	3000	3680	4600	5000	6000
	Maximum Apparent Power (VA)	3000	3680	4600	5000	6000
	Rated Output Voltage (V)	220/230/240, L+N+PE				
	Rated Output Current (A)	13.1	16	20	21.7	26.1
	Maximum Output Current (A)	15	18.4	23	25	30
	Nominal Frequency (Hz)	50/60				
	Total Harmonic Distortion (At Rated Power)	≤5%	≤5%	≤3%	≤3%	≤3%
	Power Factor	-0.8...1...+0.8				
AC Output (Backup load)	Inrush Current (Peak Value/Duration Time) (A)	92@3μs				
	Maximum Output Fault Current (Peak Value/Duration Time) (A)	108@2.8μs				
	Maximum Output Power (VA)	3000	3680	4600	5000	6000
	Nominal Output Voltage (V)	220/230/240, L+N+PE				
	Nominal Frequency (Hz)	50/60				
	Maximum Output Current (A)	16	19.7	24.6	26.7	32
Efficiency	Rated Output Current (A)	13.1	16	20	21.7	26.1
	Inrush Current (Peak Value/Duration Time) (A)	92@3μs				
Efficiency	Maximum Output Fault Current (Peak Value/Duration Time) (A)	108@2.8μs				
	Maximum Efficiency	>96%			>96.5%	
Protection	European Weighted Efficiency	>95%			>96%	
	GFCI	Supported				
	Insulation Resistance Detection	Supported				
	Anti-Islanding Protection	Supported				
	PV Reverse Polarity Protection	Supported				
	AC Overcurrent Protection	Supported				
	AC Short-Circuit Protection	Supported				
Compliance	AC Overvoltage Protection	Supported				
	Protective Class	I				
	Certificates	CE/CB/DEKRA MARK				
	Safety Standard	IEC/EN62109-1, IEC/EN62109-2				
Compliance	Grid-Tied Standards	G98, G99, G100, VDE-AR-N 4105, CEI 0-21, UTE C15-712-1, VDE 0126-1-1, EN 50549-1, C10/11, NTS631, UNE 217001, UNE 217002, PPDS, PTPIREE, PSE, NC RFG, ORDINANCE No.140, NRS 097-2-1				
	EMC	EN/IEC 61000-6-1/2/3/4, IEC 61000-4-16/18/29, IEC 61000-2-2, EN 300328, EN 301489-1, EN 301489-17, EN IEC 62311				
General	Topology	Non-isolated				
	Ingress Protection Rating	IP65				
	Operating Temperature Range (°C)	-20 to 50 (derating when the temperature is above 40 or below 0)				
	Storage Temperature Range (°C)	-30 to 60				
	Operating Humidity	0%-100% (Condensing)				
	Maximum Operating Altitude (m)	3000 (derating above 2000)				
	Weight (kg)	21.5				
	Dimensions (WxDxH) (mm)	679,6x182,7x280 (without IOT & Wi-Fi module)				
	Noise Emission (dB)	40				
	Self-Consumption at Night (W)	<30				
	Cooling Method	Natural Convection				
	Communication Method	RS485 & CAN & Wi-Fi & Bluetooth & WAN & 4G				
	Wi-Fi	Frequency Range: 2400 MHz-2483,5 MHz, Maximum Output Power: 17 dBm				
	Bluetooth	Frequency Range: 2400 MHz-2483,5 MHz, Maximum Output Power: 8 dBm				
Pollution Degree	PD3					
Environmental Category	Outdoor/Indoor					

Appendix: Network security & Vulnerability Disclosure

CHANGE MECHANISMS

Users can change their login identity by switching accounts and entering the password corresponding to that account on EcoFlow App login page. See the **Installation Guide** delivered with the inverter.

SENSORS

- The device is connected to a smart meter via an RS485 interface for power sampling.
- The device comes with built-in NTC to sample the internal inverter temperature for control strategies.

SECURITY SETTING

Users will be instructed to set an access password during the initial binding of the device. See the **Installation Guide** delivered with the inverter.

SETUP CHECK

Each input by the user is checked based on the validation rules. The only scenario where the user can make an insecure input is creating a new user account. If the password entered does not comply with the password rules, the app immediately notifies the user via a pop-up window, and the setup process can only proceed when the user enters valid characters.

PERSONAL DATA

The device will record the hotspot information of the wifi accessed by the user so that the device can automatically connect to the corresponding hotspot after re-powering on without having to re-enter the information.

TELEMETRY DATA

- Telemetry parameters include home load power consumption, PV production, grid usage, etc., to be revealed to the user via EcoFlow App or web portal.
- Telemetry parameters include internal inverter parameters such as current, voltage, temperature, etc., which are used for safety diagnosis of the device.

ERASING DATA

Users can visit the home page of the EcoFlow App, and delete the corresponding data by tapping the following in sequence "Settings" -> "Reset and erase data".

MODEL DESIGNATION

- EF HD-P1-3K-S1
- EF HD-P1-3.68K-S1
- EF HD-P1-4.6K-S1
- EF HD-P1-5K-S1
- EF HD-P1-6K-S1

SUPPORT PERIOD

This device under test is actively maintained concerning security updates for the following 12 years after market launch.

VULNERABILITY DISCLOSURE POLICY

For the Vulnerability Disclosure Policy, users can visit Ecoflow's official website at

https://account.ecoflow.com/agreement/en-uk/EFSRC_Vulnerability_Disclosure_Plan.html

EcoFlow Inc.

Address: RM 401, Plant #1, Runheng Industrial Zone, Fuyuan Road, Zhancheng Community, Fuhai Street, Bao'an District, Shenzhen City, Guangdong Province, P.R.China
Tel: 0086(0)755-23590789

EU Declaration of Conformity

We, EcoFlow Inc. declare under our sole responsibility that the products

PRODUCT: EcoFlow PowerOcean Hybrid Inverter

MODELS: EF HD-P1-3K-S1, EF HD-P1-3.68K-S1, EF HD-P1-4.6K-S1, EF HD-P1-5K-S1,
EF HD-P1-6K-S1

to which this declaration relates, is in compliance with the follow documents:

Directives:

2014/53/EU (RED)
2011/65/EU (RoHS)
(EU)2015/863 (RoHS)

Product Safety and Performance Standard(s):

EN 62109-1:2010
EN 62109-2:2011

Health Standards:

EN IEC 62311:2020

EMC Standards:

EN IEC 61000-6-1:2019
EN IEC 61000-6-2:2019
EN IEC 61000-6-3:2021
EN IEC 61000-6-4:2019
ETSI EN 301489-1 V 2.2.3 (2019-11)
ETSI EN 301 489-17 V3.2.4 (2020-09)
EN IEC 61000-3-2:2019
EN 61000-3-3:2013+A1:2019
EN IEC 61000-3-11:2019
EN 61000-3-12:2011

Radio Standards:

ETSI EN 300 328 V2.2.2 (2019-07)

RoHS Standards:

IEC 62321-3-1:2013
IEC 62321-5:2013
IEC 62321-4:2013+AMD1:2017
IEC 62321-7-1:2015
IEC 62321-7-2:2017
IEC 62321-6:2015
IEC 62321-8:2017

EU Representative:

EcoFlow Europe s.r.o
Doubravice 110, 533 53 Pardubice, Czech Republic



Signed for and on behalf of:

signature and seal

Compliance Engineer
position

2024-03-06
date of issue

