



WE MEASURE ELECTRICITY

PRODUCT CATALOG



EASTRON

Web: www.eastrongroup.com

E-mail: sales@eastrongroup.com

Tel: +86-573-83698881 Fax: +86-573-83698883

Add: No.1369,Chengnan Rd. Jiaxing, Zhejiang, 314001, China

Zhejiang Eastron Electronic Co., Ltd.

CHINA · JIAXING

COMPANY INTRODUCTION

Eastron Electronic Co., Ltd., headquartered in Jiaxing, China, is one of the leading high-tech manufacturer and supplier for electricity products and energy measurement solutions. Over the years, we have developed a rich range of electricity meters, sensors, communication modules and management systems. Our products are widely used in such applications as:

- Original Equipment Manufacturers (Switchboard/ Panel Boards, EV Charging Points and Infrastructures)
- System Integrators for remote monitoring (Energy Analysis, Smart Buildings and Billing Applications)
- Renewable energy (Solar, Wind)

Eastron keeps investing on the research and development of new technology and new products on electricity metering. We have energetic and innovative development teams in both China and UK. That help us keep the competitive edge in the market. The collaboration with leading university and institution also brings many cutting-edge technology into our products. To make sure the reliability of the products, Eastron has setup own professional lab that can performs EMC, LVD, Accuracy and environment tests according to IEC, EN, GB, UL standards.

With more than 40 patented technologies on software, embedded software and hardware, Eastron has been awarded with “High-tech Enterprise” and “High-tech R&D Centre of Electricity Application”. Eastron strictly follows ISO 9001 Quality management system, and the production is approved by SGS according to MID standard.

We have 55000 ft² fully ESD-controlled production facility. The production covers SMT, Wave soldering, Automatic DIP, Calibration, Aging etc. All products are well protected, properly proceeded, precisely calibrated and fully tested. Automation is widely used in processing. Eastron runs the ERP and MES systems, which make sure all materials, products and production information are under control and traceable.

Create value to and grow up with our partners is our mission. Eastron provides not only the high quality and innovative products, but also first class service to all our customers. We have professional team for technical supports and aftersales services. We have provided products and services to more than 50 countries in Europe, Asia-Pacific, America, Middle East, and Africa. We pride ourselves on having long term partners globally that allow us to further our growth and bring our innovation and quality to the market.

Eastron, your trustable partner for ever.

Persuing the excellence of quality

Climbing the peak of technology



What's MID?

The Measuring Instruments Directive (2014/32/EU) is a directive by the European Union, which seeks to harmonise many aspects of legal metrology across all member states of the EU. Its most prominent tenet is that all kinds of meters which receive a MID approval may be used in all countries across the EU.

Conditions of application

In the European Union, the use of MID-certificated meters on "Private" electrical networks has been mandatory in the context of active energy billing based on consumption reading by index differences. Typical examples includes: camping sites, holiday rentals, student accommodations, office buildings, shopping centers, marinas, exhibition halls, electric vehicle recharging station, etc.

As the MID is applicable to all European Union Member States, certification of ammeter by a Notified Body(NB) means that no other testing by a national legal metrological service is required. So a MID certificated Eastron meter can be used as an active energy billing meter in all European Union countries.

The Directive also imposes product certification according to the EN50470-1/-3 standards, as well as design certification (Module B) and manufacturing process certification(Module D) by a Notified Body. In order to ensure product traceability and guarantee its metrological value, thus to protect consumers.

Certificates MID B +D we have:



Which products of us are MID approved by SGS.

Till present, Eastron has the MID approved models cover these items:



MID becomes the ONLY accepted European Legislation from 2016!

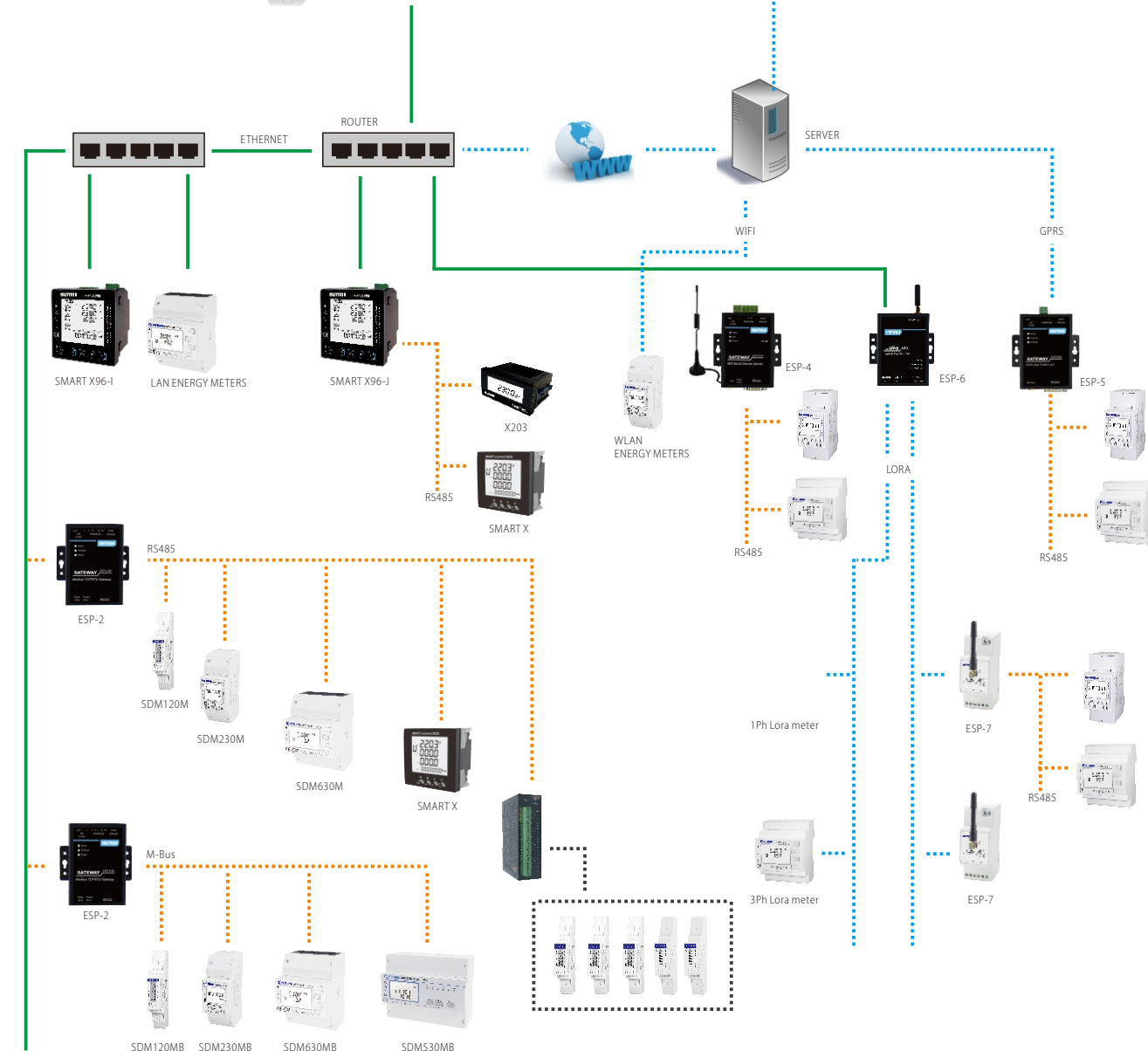

SDM120 SERIES

> Single Phase



Model	Specifications	Description	Output
SDM 120A	230V,0.25~5(45)A, Analogue	Active Energy(kWh)	Pulse output
SDM 120D/DB	230V / 110V,0.25~5(45)A	Active Energy(kWh)	Pulse output
SDM 120P	230V / 110V,0.25~5(45)A	Multi-parameters, Imp & Exp	2 Pulse output
SDM 120M	230V / 110V,0.25~5(45)A	Multi-parameters, Imp & Exp	RS485 Modbus + 2 Pulse Output
SDM 120MB	230V / 110V,0.25~5(45)A	Multi-parameters, Imp & Exp	Mbus + 2 Pulse Output
SDM 120CTM	230V / 110V,0.25~5(6)A	Multi-parameters, Imp & Exp	RS485 Modbus + 2 Pulse Output
SDM 120CTP	230V / 110V,0.25~5(6)A	Multi-parameters, Imp & Exp	2 Pulse output
SDM 120CT-MB	230V / 110V,0.25~5(6)A	Multi-parameters, Imp & Exp	RS485 Mbus + 2 Pulse Output
SDM 120CT-MV	230V / 110V, 100mV CT	Multi-parameters, Imp & Exp	RS485 Modbus + 2 Pulse Output

SDM220 SERIES

> Single Phase



Model	Specifications	Description	Output
SDM220Modbus	230V/110V,0.25~5(100)A	Multi-parameters, Imp & Exp	RS485 Modbus + 2 Pulse Output
SDM220Mbus	230V/110V,0.25~5(100)A	Multi-parameters, Imp & Exp	Mbus + 2 Pulse Output
SDM220MT	230V/110V,0.25~5(100)A	Multi-parameters, Imp & Exp, 4 Tariffs	RS485 Modbus + 2 Pulse Output
SDM220Pulse	230V/110V,0.25~5(100)A	Multi-parameters, Imp & Exp	Pulse Output
SDM220Std	230V/110V,0.25~5(100)A	Imp & Exp (kWh & W)	RS485 Modbus + 2 Pulse Output

SDM230 SERIES

> Single Phase



Model	Specifications	Description	Output
SDM230A	230V,0.5~10(100)A, Analogue	Active Energy(kWh)	Pulse Output
SDM230D	230V/110V,0.5~10(100)A	Active Energy(kWh)	Pulse Output
SDM230DR	230V,0.5~10(100)A	Active Energy(kWh & W), Resettable	Pulse Output
SDM230Bi	230V,0.5~10(100)A	Active Energy(kWh & W), Imp & Exp, Resettable, Imp & Exp	Pulse Output
SDM230Modbus	230V,0.5~10(100)A	Multi-parameters, Imp & Exp	RS485 Modbus + 2 Pulse Output
SDM230Mbus	230V,0.5~10(100)A	Multi-parameters, Imp & Exp	Mbus + 2 Pulse Output
SDM230Pulse	230V,0.5~10(100)A	Multi-parameters, Imp & Exp	RS485 Modbus + 2 Pulse Output
SDM230Standard	230V,0.5~10(100)A	Active Energy(kWh), Imp & Exp (kWh & W)	RS485 Modbus + 2 Pulse Output
SDM230-2T	230V,0.5~10(100)	Multi-parameters, Imp & Exp, 2 Tariff (Dual Power Source)	RS485 Modbus + 2 Pulse Output
SDM230-LoRaMESH	230V,0.5~10(100)	Multi-parameters, Imp & Exp	LoRaMesh + 2 Pulse Output
SDM230-LoRaWAN	230V,0.5~10(100)	Multi-parameters, Imp & Exp	LoRaWAN + 2 Pulse Output

SDM320 SERIES

> Single Phase



Model	Specifications	Description	Output
SDM320Y-D	230V,0.5~10(100)A	Energy(kWh)	Pulse Output
SDM320E	230/110V,0.5~10(100)A	Energy(kWh), 1P3W	Pulse Output
SDM320E-M	230V,0.5~10(100)A	Energy(kWh), 1P3W	RS485 Modbus + Pulse Output
SDM320Y-RF	230, 0.5~10(80)A	Multi-parameters, Imp & Exp, Prepaid	RS485 Modbus + Pulse output

SDM72 CT SERIES

> Three Phase



Model	Specifications	Description	Output
SDM72CT-D	3X230/400V,0.25~5(6)A	Active Energy(kWh)	Pulse Output
SDM72CTM	3X230/400V,0.25~5(6)A	Active Energy(kWh & W), Imp & Exp, Resettable	RS485 Modbus + 2 Pulse Output

SDM72 SERIES

> Three Phase



Model	Specifications	Description	Output
SDM72D	3X230(400)V,0.5~10(100)A,50/60Hz	Active Energy(kWh)	Pulse Output
SDM72DR	3X230(400)V,0.5~10(100)A,50/60Hz	Active Energy(kWh & W), Resettable	Pulse Output
SDM72BI	3X230(400)V,0.5~10(100)A,50/60Hz	Active Energy(kWh & W), Imp & Exp, Resettable	2 Pulse Output
SDM72DM	3X230(400)V,0.5~10(100)A,50/60Hz	Active Energy(kWh & W), Imp & Exp, Resettable	RS485 Modbus + 2 Pulse Output

SDM630 100A V1 SERIES

> Three Phase



Model	Specifications	Description	Output
SDM630Pulse	3X230/400V,0.5~10(100)A	Multi-parameters, Imp & Exp	2 Pulse Output
SDM630Std	3X230/400V,0.5~10(100)A	Active Energy(kWh), Imp & Exp (kWh & W)	RS485 Modbus + 2 Pulse Output
SDM630Modbus	3X230/400V,0.5~10(100)A	Multi-parameters, Imp & Exp	RS485 Modbus + 2 Pulse Output
SDM630Mbus	3X230/400V,0.5~10(100)A	Multi-parameters, Imp & Exp	Mbus + 2 Pulse Output
SDM630MT	3X230/400V,0.5~10(100)A,	Multi-parameters, Imp & Exp, 4 Tariff (RTC)	RS485 Modbus + 2 Pulse Output
SDM630-2T	3X230/400V,0.5~10(100)A	Multi-parameters, Imp & Exp, 2 Tariff (Dual Power Source)	RS485 Modbus + 2 Pulse Output

SDM630 100A V2 SERIES

> Three Phase



Model	Specifications	Description	Output
SDM630Pulse V2	3X230/400V,0.5~10(100)A	Multi-parameters, Imp & Exp	2 Pulse Output
SDM630Std V2	3X230/400V,0.5~10(100)A	Active Energy(kWh), Imp & Exp (kWh & W)	RS485 Modbus + 2 Pulse Output
SDM630Modbus V2	3X230/400V,0.5~10(100)A	Multi-parameters, Imp & Exp	RS485 Modbus + 2 Pulse Output
SDM630Mbus V2	3X230/400V,0.5~10(100)A	Multi-parameters, Imp & Exp	Mbus + 2 Pulse Output
SDM630MT V2	3X230/400V,0.5~10(100)A,	Multi-parameters, Imp & Exp, 4 Tariffs (RTC)	RS485 Modbus + 2 Pulse Output
SDM630-2T V2	3X230/400V,0.5~10(100)A	Multi-parameters, Imp & Exp, 2 Tariffs (Dual Power Source)	RS485 Modbus + 2 Pulse Output

SDM630 MCT SERIES

> Three Phase



Model	Specifications	Description	Output
SDM630MCT	3X230/400V,1A or 5A	Multi-parameters, Imp & Exp	RS485 Modbus + 2 Pulse Output
SDM630MCT-Mbus	3X230/400V,1A or 5A	Multi-parameters, Imp & Exp	Mbus + 2 Pulse Output
SDM630MCT-2T	3X230/400V,1A or 5A	Multi-parameters, Imp & Exp, 2 Tariff (Dual Power Source)	RS485 Modbus + 2 Pulse Output
SDM630MCT-MT	3X230/400V,1A or 5A	Multi-parameters, Imp & Exp, 4 Tariff (RTC)	RS485 Modbus + 2 Pulse Output
SDM630MCT-MV	3X230/400V, 333mV CT	Multi-parameters, Imp & Exp	RS485 Modbus + 2 Pulse Output
SDM630MCT-RJ	3X230(400)V,100mA or 333mV CT	Multi-parameters, Imp & Exp, Rj12 CTs	RS485 Modbus
SDM630MCT-2L	3X230(400)V,100mA or 333mV CT	Multi-parameters, Imp & Exp, Multi-Circuit	RS485 Modbus
SDM630MCT-LoRa	3X230(400)V,100mA or 333mV CT	Multi-parameters, Imp & Exp	LoraMESH + 2 Pulse Output
SDM630MCT-LoRaWAN	3X230(400)V,100mA or 333mV CT	Multi-parameters, Imp & Exp	LoraWAN + 2 Pulse Output
SDM630MCT-RC	3X230(400)V,100mA or 333mV CT	Multi-parameters, Imp & Exp, Rogowski coil	RS485 Modbus + 2 Pulse Output

SDM630 2C SERIES

> Multi-Circuit



Model	Specifications	Description	Output
SDM630 MCT-2C	3X230(400)V,1A or 5A,50/60Hz	Multi-parameters, Imp & Exp, Dual-load	RS485 Modbus +2 Pulse Output
SDM630 MV-2C	3X230(400)V,333mV CT ,50/60Hz	Multi-parameters, Imp & Exp, Dual-load	RS485 Modbus +2 Pulse Output

SDM530 SERIES

> Three Phase



Model	Specifications	Description	Output
SDM530D	3X230(400)V,0.5~10(100)A	Active Energy(kWh)	Pulse output
SDM530D-2T	3X230(400)V,0.5~10(100)A	Active Energy(kWh),2 tariff (Dual Power Source)	Pulse output
SDM530-Modbus	3X230(400)V,0.5~10(100)A	Multi-parametters, Imp & Exp	RS485 Modbus +2 Pulse output
SDM530-DO	3X230(400)V,0.5~10(100)A	Multi-parametters, Imp & Exp	RS485 Modbus +2 Pulse output +DO
SDM530-Mbus	3X230(400)V,0.5~10(100)A	Multi-parametters, Imp & Exp	Mbus+2 Pulse output
SDM530-MT	3X230(400)V,0.5~10(100)A	Multi-parametters, Imp & Exp, 4 tariff (RTC)	RS485 Modbus +2 Pulse output
SDM530CT-Modbus	3X230(400)V,1A or 5A	Multi-parametters, Imp & Exp	RS485 Modbus +2 Pulse output
SDM530CT-Mbus	3X230(400)V,1A or 5A	Multi-parametters, Imp & Exp	Mbus+2 Pulse output
SDM530CT-MT	3X230(400)V,1A or 5A	Multi-parametters, Imp & Exp, 4 tariff (RTC)	RS485 Modbus +2 Pulse output

REMOTE CONTROL SERIES



Model	Specifications	Description	Output
SDM320C	230V, 0.5~10(80)A	Multi-parametters, Imp & Exp	RS485 Modbus + Pulse output
SDM320Y	230V, 0.5~10(80)A	Multi-parametters, Imp & Exp, Prepaid	RS485 Modbus + Pulse output
SDM530C	3X230(400)V, 3x0.5~10(80)A	Multi-parametters, Imp & Exp	RS485 Modbus + Pulse output
SDM530Y	3X230(400)V, 3x0.5~10(80)A	Multi-parametters, Imp & Exp, Prepaid	RS485 Modbus + Pulse output

MULTI CIRCUIT MONOTRING SOLUTION



Model	Specifications	Description
MCS-I30	3x CT operated RJ12 input	Current , power, energy,Multi-Parameters
MCS-I31	3x CT operated RJ12 input	Current , power, energy, THD-i,Multi-Parameters,THD
MCS-I32	3x CT operated RJ12 input	Current , power, energy, THD-i, Overcurrent,Multi-Parameters,THD,Demand,Alarm
MCS-U20	3x230/400V; 3x127/220V	Voltage , Frequency
MCS-U21	3x230/400V; 3x127/220V	Voltage , Frequency, THD-u,Alarm
MCS-U22	3x230/400V; 3x127/220V	Voltage , Frequency, THD-u, Alarm,RS485 Modbus
MCS-D40	230V ac / 24V dc. Aux. supply	Graphical display ; RS485 Modbus;
MCS-D50	230V ac / 24V dc. Aux. supply	Graphical display ; RS485 Modbus; Ethernet
MCS-D60	230V ac / 24V dc. Aux. supply	Graphical display ; RS485 Modbus; Ethernet; Web server

SMART X96 SERIES

> Three Phase



Model	Specifications	Description	Output
Smart X96-1A	3x230/400V, 100mA 3P4W, 3P3W, 2P3W, 1P2W	85electricparametersmeasured; Class1.0/0.5s;2~63rdTHD;self-powersupply;	RS485Modbus+2Pulseoutput
Smart X96-5A	3x230/400V, 1A or5A 3P4W, 3P3W, 2P3W, 1P2W	85electricparametersmeasured; Class1.0/0.5s;2~63rdTHD;self-powersupply;	RS485Modbus+2Pulseoutput

SMART X96-5 SERIES

> Three Phase



Model	Specifications	Description	Output
Smart X96-5F	3x230/400V, 1A or5A 3P4W, 3P3W, 2P3W, 1P2W	85electricparametersmeasured; Class1.0/0.5s/0.2s;2~63rdTHD;Aux.powersupply;	RS485Modbus
Smart X96-5G	Sameas Model"F"	Model"F"+4DI and2DO	RS485Modbus+DI/DO
Smart X96-5H	Sameas Model"F"	Model"F"+Ethernetport	RS485Modbus+ModbusTCP
Smart X96-5I	Sameas Model"F"	Model"F"+Ethernetport+4DI and2DO	RS485Modbus+ModbusTCP+DO
Smart X96-5J	Sameas Model"F"	Model"F"+EthernetGateway(RTUtoTCP) +4DIand2DO	RS485Modbus+ModbusTCP+DO
Smart X96-Lora	Sameas Model"F"	Model"F"+LoraCommunication	RS485Modbus+LoRaMesh
Smart X96-RC	3x230/400V, Rogowski coil 3P4W, 3P3W, 2P3W, 1P2W	85electricparametersmeasured,CT&PTprogrammable; Class1.0/0.5s/0.2s; Aux.powersupply;	RS485Modbus

SMART X835 SERIES

> Three Phase



Model	Specifications	Description	Output
Smart X835P	3x230/400V, 1A/5A 3P4W, 3P3W, 1P2W	Multi-parametters;CT&PTprogrammable; Class1.0/0.5s;2~31stTHD;Aux.powersupply	RS485Modbus
Smart X835B	3x230/400V, 1A/5A 3P4W, 3P3W, 1P2W	Multi-parametters;CT&PTprogrammable; Class1.0/0.5s;2~31stTHD;Aux.powersupply	RS485Modbus+2Pulseoutput
Smart X835-A0	3x230/400V, 1A/5A 3P4W, 3P3W, 1P2W	Multi-parametters;CT&PTprogrammable; Class1.0/0.5s;2A0;2~31stTHD;Aux.powersupply	RS485Modbus+2A0+2Pulseoutput
Smart X835 DIO	3x230/400V, 1A/5A 3P4W, 3P3W, 1P2W	Multi-parametters;CT&PTprogrammable;Aux.powersupply; Class1.0/0.5s;2DO;2DI;2~31stTHD	RS485Modbus+2DI/DO+2Pulseoutput

SMART Connect X835 SERIES

> Three Phase



Model	Specifications	Description	Output
Smart Connect X835 CT	3x230(400)V AC, 1A or5A	Multifunction, Class1.0 / 0.5s, 31st THD	RS485Modbus+2Pulseoutput
Smart Connect X835 MV	3x230(400)V AC, 333mV	Multifunction, Class1.0 / 0.5s, 31st THD	RS485Modbus+2Pulseoutput
Smart Connect X835 A	1A or5A	3Phase current;Class0.5s/0.2s	RS485Modbus
Smart Connect X835 V	3x230(400)V	3PhaseVoltage;Class0.5s/0.2s	RS485Modbus
Smart Connect X835 W	3x230(400)V AC, 1A or5A	3Phasecurrent,VoltageandPower;Class0.5s/0.2s	RS485Modbus

SMART X72 SERIES

> Three Phase



Model	Specifications	Description	Output
Smart X72-F	3x230/400V, 1A or5A 3P4W, 3P3W, 2P3W, 1P2W	85electricparametersmeasured;CT&PTprogrammable; Class1.0/0.5s/0.2s;2~63rdTHD;Aux.powersupply;	RS485Modbus
Smart X72-G	SameasModel"F"	Model"F"+4DI and2DO	RS485Modbus+DI/DO
Smart Connect X72 A	1A or5A	3Phase current;Class0.5s/0.2s	RS485Modbus
Smart Connect X72 V	3x230(400)V	3PhaseVoltage;Class0.5s/0.2s	RS485Modbus
Smart Connect X72 W	3x230(400)V AC, 1A or5A	3Phasecurrent,VoltageandPower;Class0.5s/0.2s	RS485Modbus

ESP-2 SERIES > Ethernet Gateway



Model	Input	Output	Power supply
ESP-2100	RS232/485/422 x1; 1200~115200bps	Ethernet TCP 10/100Mbps	9~24V DC, 350W
ESP-2200	RS232/485/422 x2; 1200~115200bps	Ethernet TCP 10/100Mbps	9~24V DC, 4W
ESP-2400	RS232/485/422 x4; 1200~115200bps	Ethernet TCP 10/100Mbps	9~24V DC, 4W
ESP-2800	RS232/485/422 x8; 1200~115200bps	Ethernet TCP 10/100Mbps	9~24V DC, 6W
ESP-2120	M-Bus EN13757-3; 300~9600bps	Ethernet TCP 10/100Mbps	9~24V DC, 6W

ESP-4 SERIES > wifi Gateway



Model	Input	Output	Power supply
ESP-4142	RS232/485/422; 1200~115200bps	Wifi IEEE802.11b/g/n	9~24V DC, 310mA
ESP-4104	RS232/485/422; 1200~115200bps	Wifi IEEE802.11b/g/n; Ethernet TCP 10/100M	9~24V DC, 1W

ESP-5 SERIES > GPRS DTU Gateway



Model	Input	Output	Power supply
ESP-5100	RS232/485/422; 1200~115200bps	GPRS 900Mhz/1800Mhz; Ethernet TCP	9~24V DC, 170mA@9V
ESP-5305	RS232/485/422; 1200~115200bps	3G / 4G; Ethernet TCP	9~24V DC, 200mA@9V

ESP-6 SERIES > Lora Gateway



Model	Input	Output	Power supply
ESP-6100	LoRa 470/433Mhz	Ethernet TCP 10/100M	9~24V DC, 2W
ESP-6200	LoRa 470/433Mhz	GPRS 900Mhz/1800Mhz; Ethernet TCP	9~24V DC, 2W

EST485 SERIES > Pulse Collector



Model	Input	Output	Power supply
EST485-P16	Passive Pulse x16	Rs485 Modbus	24V DC; 220V AC
EST485-P32	Passive Pulse x32	Rs485 Modbus	24V DC; 220V AC

ESP-7 SERIES > Converter



Model	Input	Output	Power supply
ESP-7100	RS 485; 1200~38400bps	LoRa 470/433Mhz	9~24V DC, 2W
ESP-7110	RS 485; 1200~38400bps	Ethernet TCP	9~24V DC, 2W
ESP-7120	RS 485; 1200~38400bps	Wifi IEEE802.11b/g/n	9~24V DC, 2W

ESCT-RJ SERIES > RJ12



Model	Primary Current	Secondary Output	Accuracy
ESCT-RJ335	60,100,125,150,200,250A	333mV / 100mV / 100mA	0.5 / 1
ESCT-RJ345	2501300,400,500,630A	333mV / 100mV / 100mA	0.5 / 1
ESCT-RJ16	5,10,20,30,50,100,150A	100mV	0.5 / 1
ESCT-RJ24	10,50,100,200,300A	100mV	0.5 / 1
ESCT-RJ36	20,50,100,200,300,400,500,600A	100mV	0.5 / 1

ESCT-SC SERIES > 3-in-1



Model	Primary Current	Secondary Current	Accuracy
ESCT-SC325	60,100,125,150,200A	1A or 5A	0.5 / 1
ESCT-SC335	60,100,125,200,250A	1A or 5A	0.5 / 1
ESCT-SC345	250,300,400,500,600,630A	1A or 5A	0.5 / 1

ESCT-C SERIES > 3-in-1



Model	Primary Current	Secondary Current	Accuracy
ESCT-C325	60,100,125,150,200A	5A / 1A	0.5 / 1
ESCT-C335	60,100,125,200,250A	5A / 1A	0.5 / 1
ESCT-C345	250,300,400,500,600,630A	5A / 1A	0.5 / 1

ESCT-B SERIES > Split Core



Model	Primary Current	Secondary Current	Accuracy
ESCT-B23	100,200,250,300,400A	5A / 1A	0.5 / 1
ESCT-B58	250,300,400,500,600,750,800,1000A	5A / 1A	0.5 / 1
ESCT-B88	200,300,400,500,600,750,800,1000A	5A / 1A	0.5 / 1
ESCT-B812	500,600,750,800,1000,1200,1250,1500A	5A / 1A	0.5 / 1
ESCT-B816	1000,1500,2000,3000,4000,5000A	5A / 1A	0.5 / 1

ESCT-T SERIES > Split Core



Model	Primary Current	Secondary Current	Accuracy
ESCT-T24	100,150,200,250,300A	5A / 1A	0.5 / 1
ESCT-T36	100,150,200,300,400,500,600A	5A / 1A	0.5 / 1

ESCT-TU SERIES > Split Core



Model	Primary Current	Secondary Current	Accuracy
ESCT-TU10	5,10,20,50,75 A	333mV / 100mV / 100mA	0.5 / 1
ESCT-TU16	5,10,50,100,150 A	333mV / 100mV / 100mA	0.5 / 1
ESCT-TU24	10,50,100,250,300A	333mV / 100mV / 100mA	0.5 / 1
ESCT-TU36	20,100,250,400,600 A	333mV / 100mV / 100mA	0.5 / 1

ESCT-U SERIES > Split Core



Model	Primary Current	Secondary Output	Accuracy
ESCT-U75	5,10,50,75,100,125,150,200 A	333mV	0.5 / 1
ESCT-U125	50,100,125,200,250,400,600,630A	333mV	0.5 / 1
ESCT-U200	100,250,400,630,800,1000,2000A	333mV	0.5 / 1
ESCT-U250	200,250,400,630,1500,2500,3000A	333mV	0.5 / 1
ESCT-U300	400,800,1000,1500,2500,3000,5000A	333mV	0.5 / 1

ESCT-RC SERIES > Rogowski Coil



Model	Primary Current	Secondary Current	Accuracy
ESCT-RC16	100A	333mV / 100mV	0.5 / 1
ESCT-RC24	300A	333mV / 100mV	0.5 / 1
ESCT-RC36	600A	333mV / 100mV	0.5 / 1
ESCT-RC60	500A	333mV / 100mV	0.5 / 1
ESCT-RC100	1000A	333mV / 100mV	0.5 / 1
ESCT-RC105	1500A	333mV / 100mV	0.5 / 1
ESCT-RC150	3000A	333mV / 100mV	0.5 / 1
ESCT-RC200	6000A	333mV / 100mV	0.5 / 1
ESCT-RC240	10000A	333mV / 100mV	0.5 / 1

ESCT-ABO SERIES > Solid Core



Model	Primary Current	Secondary Current	Accuracy
ESCT-AB030	50,60,75,80,100,150,200,250,300A	5A	0.5S / 0.5
ESCT-AB040	75,80,100,150,200,250,300,400,500A	5A	0.5S / 0.5
ESCT-AB060	200,250,300,400,500,600,750,800,1000A	5A	0.5S / 0.5
ESCT-AB0100	800,1000,1200,1500,1600,2000,2500,3000A	5A	0.5S / 0.5

ESCT-DM SERIES > Solid Core



Model	Primary Current	Secondary Current	Accuracy
ESCT-DM20/30	50,60,75,80,100,125,150,200,250,300 A	5A	1
ESCT-DM20/35	50,60,75,80,100,125,150,200,250,300 A	5A	1

ESRD TMS SERIES > Digital multifunction time relay



Model	Specifications	Description	Size
ESRD-TMS1	AC/DC 24-240V,50/60Hz	1C/O+1NO contacts, 0s-99h59min59sec, Backlit, LCD display	2 Module
ESRD-TMS2	AC/DC 24-240V,50/60Hz	1C/O+1NO contacts, 0-9999s, 0-9999min, Backlit, LCD display	2 Module

ESRD TPA SERIES > Single channel astronomical time switch



Model	Specifications	Description	Size
ESRD-TPA1	AC220-240V,50/60Hz	Single Channel, 40 programs, LCD display, Holiday mode, Automatic	2 Module

ESRD TPW SERIES > Digital weekly time switch



Model	Specifications	Description	Size
ESRD-TPW1	AC220-240V,50/60Hz	Single Channel, 40 programs, LCD display, Holiday mode, Automatic	2 Module
ESRD-TPW2	AC/DC24-264V,50/60Hz	Double Channel, 100 programs, Backlit, LCD, Holiday mode, Automatic	2 Module

ESRD ST SERIES > Twilight switch



Model	Specifications	Description	Size
ESRD-ST1	230V,50/60Hz, 1NO	Fixed watching on and off delay, LED indication	2 Module

ESRSTM SERIES > Multifunction time relay



Model	Specifications	Description	Size
ESRS-TM11	AC 220V,50/60Hz	10 operating modes, 10 time ranges, LED indication	1 Module
ESRS-TM12	A1-A2:AC220V; A3-A2; AC / DC24V,50/60Hz	10 operating modes, 10 time ranges, LED indication	1 Module
ESRS-TM14	AC/DC 12-240V,50/60Hz	10 operating modes, 10 time ranges, LED indication	1 Module
ESRS-TM23	AC/DC 24-240V,50/60Hz	10 operating modes, 10 time ranges, LED indication	1 Module

ESRSTSL SERIES > Staircase light timer



Model	Specifications	Description	Size
ESRS-TSL	230V,50/60Hz	3 operation modes, 3 wire or 4 wire connection	1 Module



SDM120 Modbus / Mbus/Pulse

SINGLE PHASE MULTI-FUNCTION ENERGY METER

- 45A direct load
- 1 module 17.5mm wide
- Multi-measurement: kWh, W, V, A, PF, Hz, dmd.etc.
- Bi-directional measurement
- 2 Pulse outputs
- RS485 Modbus or M-bus communication



Introduction

SDM120-45A series are advanced single phase energy monitoring solution with built-in configuration push button and LCD data displaying, particularly indicated for energy and other parameters metering and for cost allocation. Housing for DIN-rail mounting, IP51 protection degree, direct connection up to Max 45A. Moreover the meter can be provided with a pulses output proportional to the active energy being measured and a RS485 output/ M-bus output port for remote monitoring. It is an ideal choice as a sub-meter for AMR system or SCADA system.

This series has been assessed and certified as meeting the requirements of EU Directive 2014/32/EU. The EU Type Examination Certificate Number is 0120/SGS0141.



SDM120—M—1—1

- P: Multi-parameters, 2 Pulse outputs
- M: Multi-parameters, 2 Pulse outputs + RS485 Modbus RTU
- MB: Multi-parameters, 2 Pulse outputs + M-Bus Communication
- 1: 110V/120V AC
- 2: 220V/230V AC
- 1: MID
- 2: Non-MID

Specification	
Nominal voltage(Un)	120V or 230V ac
Operational voltage	80%~120% of Un
Insulation capabilities	
- AC voltage withstand	4KV for 1 minute
- Impulse voltage withstand	6KV-1.2μS
Basic current (Ib)	5A
Maximum rated current (Imax)	45A
Operational current range	0.4% Ib-Imax
Over current withstand	30 Imax for 0.01s
Operational frequency range	50 / 60Hz
Internal power consumption	≤ 2W/10VA
Pulse output	1000imp/kWh
Display	LCD with backlight
Max reading	99999.9 kWh/kVarh

Performance criteria	
Operating humidity	≤ 90%
Storage humidity	≤ 95%
Operating temperature	-25°C - +55°C
Storage temperature	-40°C - +70°C
Reference temperature	23°C± 2°C
International standard	IEC 62053-21 / EN50470-1/3
Accuracy class	Class1/Class B
Installation category	CAT II
Mechanical environment	M1
Electromagnetic environment	E2
Degree of pollution	2
Protection against penetration of dust and water	IP51(indoor)
Insulating encased meter of protective class	II
Altitude	up to 2000m
Electrostatic discharges	8kV contact / 15kV air gap
Electromagnetic HF fields	IEC 61000-4-3
Electrical fast transients	4kV
Surge	4kV
Radiated & conducted emissions	EN 55022

Accuracy	
Voltage,Current	0-5%
Frequency	0-2% of mid-frequency
Power factor	1% of unity (0.01)
Active power , Apparent power	±1% of range maximum
Reactive power	±1% of range maximum
Reactive energy(Varh)	Class 2
Active energy (Wh)	Class 1

Modbus	
Bus type	RS485(semi-duplex)
Protocol	Modbus RTU
Baud rate	1200/2400/4800/9600bps/19200(optional)bps
Address range	1-247
Max. Bus loading	64pcs
Communication distance	1000M
Parity	EVEN/ODD/NONE
Data bit	8
Stop bit	1

M-bus	
Bus type	M-bus
Protocol	EN13757-3
Baud rate	600/1200/2400/4800/9600/19200(optional)bps
Parity	NONE/EVEN/ODD
Stop bits	1 or 2
Primary Address	1 to 250
Secondary Address	00 00 00 01 to 99 99 99 99

Pulse output	
Pulse outputs	2
Pulse output type	Passive
Pulse Output 1	Configurable
Pulse width	200/100(default)/60ms
Pulse output 2	1000imp/kWh

Wiring diagram

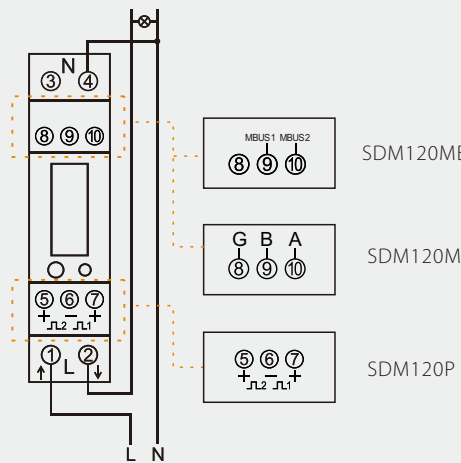

Dimensions

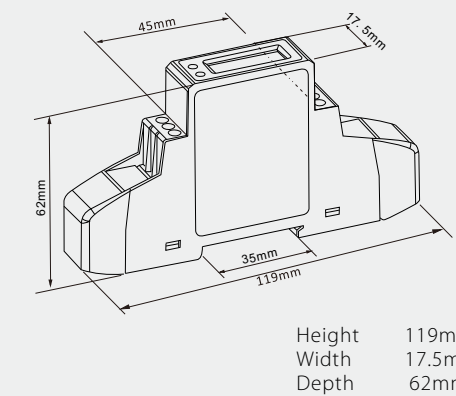



SDM120CT Modbus / Mbus / Pulse

SINGLE PHASE MULTI-FUNCTION ENERGY METER

- CT operated
- 1 module 17.5mm wide
- Multi-measurement: kWh, W, V, A, PF, Hz, dmd. etc.
- Bi-directional measurement
- 2 Pulse outputs
- RS485 Modbus or M-bus communication



Introduction

SDM120 CT series is CT operated type single phase multi-function energy meter. The meter is compactly designed in one module din rail enclosure. LCD display is provided to show the energy and other important electric parameters measured. Moreover the meter can provide with pulse outputs proportional to the energy being measured and a RS485 output/ M-bus output port for remote monitoring. CT ratio can be set, which enables this meter to measure big current load.

This series has been assessed and certified as meeting the requirements of EU Directive 2014/32/EU. The EU Type Examination Certificate Number is 0120/SGS0141.

Specification	
Nominal voltage(Un)	120V or 230V ac
Operational voltage	80%~120% of Un
Insulation capabilities	
- AC voltage withstand	4KV for 1 minute
- Impulse voltage withstand	6KV-1.2μS
Primary current	5~9999A
Secondary input	1A/5A or 100mV
Over current withstand	20 I _{max} for 0.01s
Operational frequency range	50 or 60Hz
Internal power consumption	≤ 2W/10VA
Pulse output 1	configurable
Pulse output 2	1000imp/kWh
Display	LCD with backlight
Max reading	999999 kWh/kVarh

Performance criteria	
Operating humidity	≤ 90%
Storage humidity	≤ 95%
Operating temperature	-25°C - +55°C
Storage temperature	-40°C - +70°C
Reference temperature	23°C± 2°C
International standard	IEC 62053-21 / EN50470-1/3
Accuracy class	Class1/Class B
Installation category	CAT II
Mechanical environment	M1
Electromagnetic environment	E2
Degree of pollution	2
Protection against penetration of dust and water	IP51 (indoor)
Insulating encased meter of protective class	II
Aititude	up to 2000m
Electrostatic discharges	8kV contact / 15kV air gap
Electromagnetic HF fields	IEC 61000-4-3
Electrical fast transients	4kV
Surge	4kV
Radiated & conducted emissions	EN 55022

Accuracy	
Voltage, Current	0.5%
Frequency	0.2% of mid-frequency
Power factor	1% of unity (0.01)
Active power, Apparent power	±1% of range maximum
Reactive power	±1% of range maximum
Reactive energy(Varh)	Class 2
Active energy (Wh)	Class 1

Modbus	
Bus type	RS485(semi-duplex)
Protocol	Modbus RTU
Baud rate	1200/2400/4800/9600bps/19200(optional)bps
Address range	1-247
Max. Bus loading	64pcs
Communication distance	1000M
Parity	EVEN/ODD/NONE
Data bit	8
Stop bit	1

M-bus	
Bus type	M-bus
Protocol	EN13757-3
Baud rate	600/1200/2400/4800/9600/19200(optional)bps
Parity	NONE/EVEN/ODD
Stop bits	1 or 2
Primary Address	1 to 250
Secondary Address	00 00 00 01 to 99 99 99 99

Pulse output	
Pulse outputs	2
Pulse output type	Passive
Pulse Output 1	Configurable
Pulse width	200/100(default)/60ms
Pulse output 2	1000imp/kWh

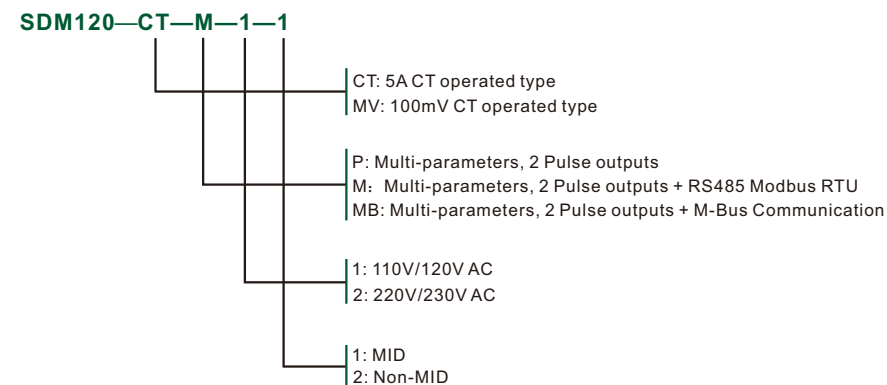

Wiring diagram

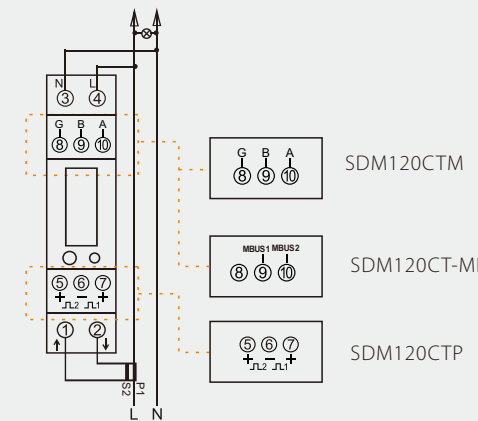

Dimensions

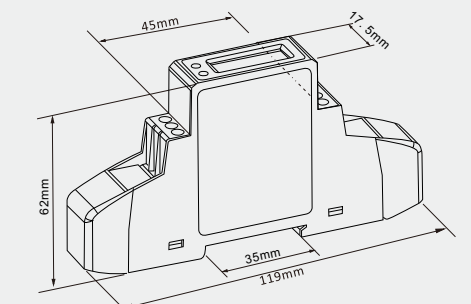

Height 119mm
Width 17.5mm
Depth 62mm



SDM220 Modbus / Mbus / MT / Std / Pulse

SINGLE PHASE MULTI-FUNCTION ENERGY METER

- 100A direct load
- 2 Module 36mm wide
- Multi-measurement:kWh,kVarh,W,Var,VA,PF,HZ,dmd,V,A,etc.
- Bi-directional measurement
- 2 Pulse outputs
- RS485 Modbus or M-bus communication
- Multi-tariffs available (RTC)



Introduction

SDM220 series is an advanced digital single phase multi-function energy meter, which measures up to 100A direct load. The unit measures active energy, reactive energy, current, voltage, power, power factor, frequency, demand, etc. Bi-directional measurement makes this unit an ideal choice for Solar PV measurement. A remote communication port is provided, RS485 Modbus RTU/M-bus EN13757-3 and Communication parameters are password protected in setup mode. User can check data and set up the meter via the buttons on the front panel.

This Series has been assessed and certified as meeting the requirements of EU Directive 2014/32/EU. The EU Type Examination Certificate Number is 0120/SGS0172.

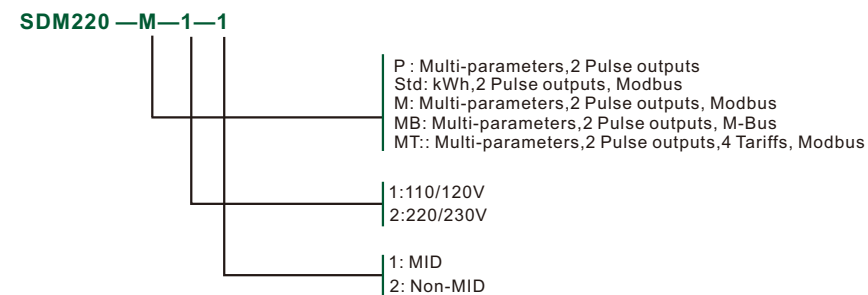

Specification	
Nominal voltage(Un)	230V ac
Operational voltage	80%~120% of Un
Insulation capabilities	
- AC voltage withstand	4KV for 1 minute
- Impulse voltage withstand	6KV-1.2μS
Basic current (Ib)	5A
Maximum rated current (Imax)	100A
Operational current range	0.4% Ib-Imax
Over current withstand	30 Imax for 0.01s
Operational frequency range	50 or 60Hz
Internal power consumption	≤ 2W/10VA
Pulse output 1	configurable
Pulse output 2	1000imp/kWh
Max reading	99999.99 kWh/kVarh

Performance criteria	
Operating humidity	≤ 90%
Storage humidity	≤ 95%
Operating temperature	-25°C - +55°C
Storage temperature	-40°C - +70°C
Reference temperature	23°C± 2°C
International standard	IEC 62053-21 / EN50470-1/3
Accuracy class	Class1/Class B
Installation category	CAT II
Mechanical environment	M1
Electromagnetic environment	E2
Degree of pollution	2
Protection against penetration of dust and water	IP51 (indoor)
Insulating encased meter of protective class	II

Multi-tariff	
time clock accuracy	< 1s/day
Tariff	4
Time segments	10

Accuracy	
Voltage,Current	0.5%
Frequency	0.2% of mid-frequency
Power factor	1% of unity (0.01)
Active power , Apparent power	±1% of range maximum
Reactive power	±1% of range maximum
Reactive energy(Varh)	Class 2
Active energy (Wh)	Class 1

Modbus	
Bus type	RS485(semi-duplex)
Protocol	Modbus RTU
Baud rate	1200/2400/4800/9600bps/19200(optional)
Address range	1-247
Max. Bus loading	64pcs
Communication distance	1000M
Parity	EVEN/ODD/NONE
Data bit	8
Stop bit	1

M-bus	
Bus type	M-bus
Protocol	EN13757-3
Baud rate	600/1200/2400/4800/9600/19200(optional)
Parity	NONE/EVEN/ODD
Stop bits	1 or 2
Primary Address	1 to 250
Secondary Address	00 00 00 01 to 99 99 99 99

Pulse Output	
Pulse outputs	2
Pulse output type	Passive
Pulse Output 1	Configurable
Pulse width	200/100(default)/60ms
Pulse output 2	1000imp/kWh

Wiring diagram

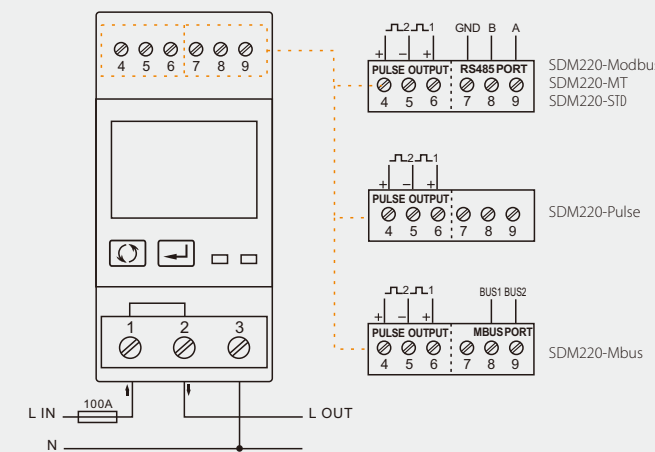

Dimensions

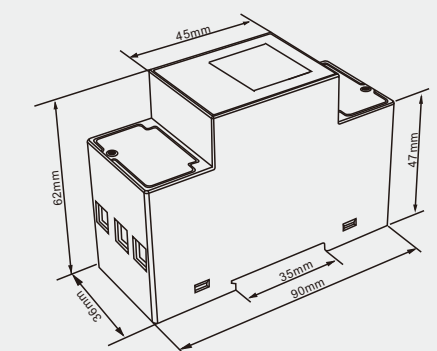

Height 90mm
Width 36mm
Depth 62mm



SDM 230 Modbus / Mbus / 2T / Std / Pulse

SINGLE PHASE MULTI-FUNCTION ENERGY METER

- 100A direct load
- 2 Module 36mm wide
- Multi-measurement:kWh,kVarh,W,Var,VA,PF,HZ,dmd,V,A,etc.
- Bi-directional measurement
- 2 Pulse outputs
- RS485 Modbus or M-bus communication
- 2 Tariffs available(dual power source)



Introduction

SDM230 series is an advanced digital single phase multi-function energy meter, which measures up to 100A direct load. The unit measures active energy, reactive energy, current, voltage, power, power factor, frequency, demand, etc. Bi-directional measurement makes this unit an ideal choice for Solar PV measurement. A remote communication port is provided, RS485 Modbus RTU or M-bus EN13757-3 and communication parameters are password protected in setup mode. User can check data and set up the meter via the buttons on the front panel. SDM230-2T can measure energy from two different power supplies.

This Series has been assessed and certified as meeting the requirements of EU Directive 2014/32/EU. The EU Type Examination Certificate Number is 0120/SGS0206.

Specification	
Nominal voltage(Un)	120V or 230V ac
Operational voltage	80%~120% of Un
Insulation capabilities	
- AC voltage withstand	4KV for 1 minute
- Impulse voltage withstand	6KV-1.2μS
Basic current (Ib)	10A
Maximum rated current (I _{max})	100A
Operational current range	0.4% I _b -I _{max}
Over current withstand	30 I _{max} for 0.01s
Operational frequency range	50 or 60Hz
Internal power consumption	≤ 2W/10VA
Pulse output 1	1000imp/kWh
Pulse output 2	1000imp/kWh
Max reading	999999.9 kWh/kVarh

Performance criteria	
Operating humidity	≤ 90%
Storage humidity	≤ 95%
Operating temperature	-25°C - +55°C
Storage temperature	-40°C - +70°C
Reference temperature	23°C± 2°C
International standard	IEC 62053-21 / IEC620532-22 / EN50470-1/3
Accuracy class	Class1/Class0.5S/Class B
Installation category	CAT II
Mechanical environment	M1
Electromagnetic environment	E2
Degree of pollution	2
Protection against penetration of dust and water	IP51(indoor)
Insulating encased meter of protective class	II
Electrostatic discharges	8kV contact / 15kV air gap
Electromagnetic HF fields	IEC 61000-4-3
Electrical fast transients	4kV
Surge	4kV
Radiated & conducted emissions	EN 55022

Accuracy	
Voltage,Current	0.5%
Frequency	0.2% of mid-frequency
Power factor	1% of unity (0.01)
Active power , Apparent power	±1% of range maximum
Reactive power	±1% of range maximum
Reactive energy(Varh)	Class 2
Active energy (Wh)	Class 1/Class0.5S

Modbus	
Bus type	RS485(semi-duplex)
Protocol	Modbus RTU
Baud rate	1200/2400/4800/9600bps/19200(optional)
Address range	1-247
Max. Bus loading	64pcs
Communication distance	1000M
Parity	EVEN/ODD/NONE
Data bit	8
Stop bit	1

M-bus	
Bus type	M-bus
Protocol	EN13757-3
Baud rate	600/1200/2400/4800/9600/19200(optional)
Parity	NONE/EVEN/ODD
Stop bits	1 or 2
Primary Address	1 to 250
Secondary Address	00 00 00 01 to 99 99 99 99

Pulse Output	
Pulse outputs	2
Pulse output type	Passive
Pulse Output 1	Configurable
Pulse width	200/100(default)/60ms
Pulse output 2	1000imp/kWh

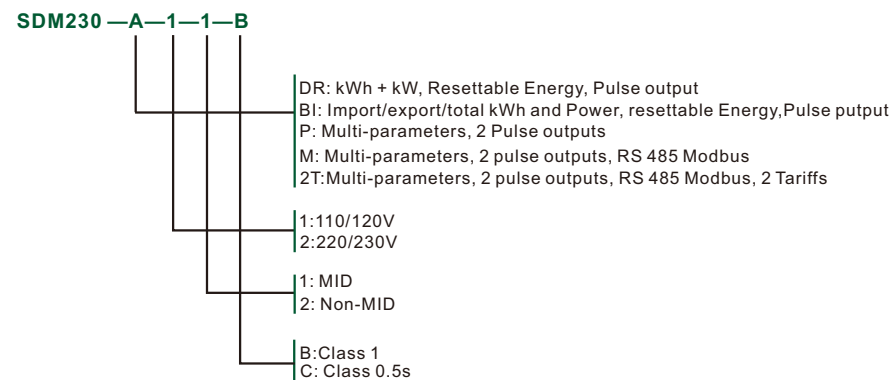

Wiring diagram

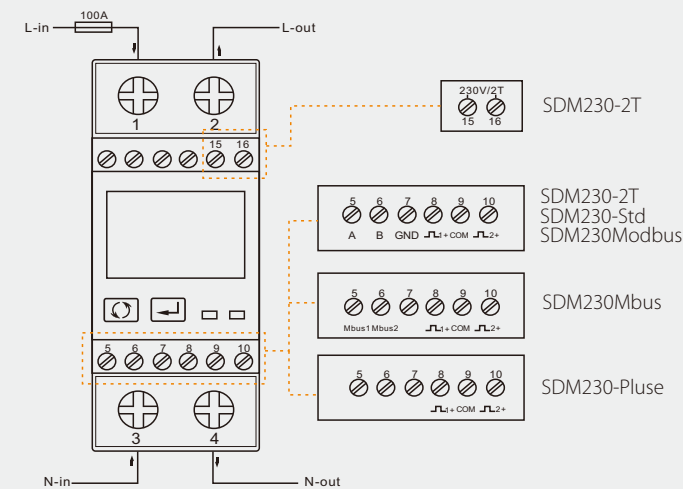

Dimensions

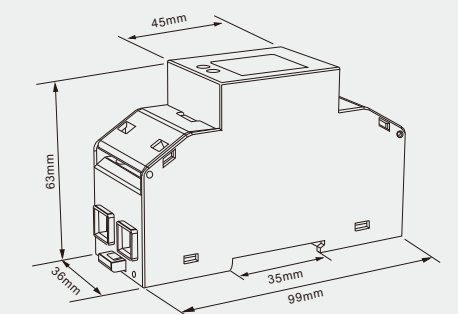

Height 99mm
Width 36mm
Depth 63mm



SDM530 Modbus / Mbus / MT / DO

THREE PHASE FOUR WIRE MULTI-FUNCTION ENERGY METER

- 100A direct load
- 7 Module wide
- Multi-measurement:kWh,kVarh,W,Var,VA,PF,HZ,dmd,V,A,etc.
- Bi-directional measurement
- 2 Pulse outputs
- RS485 Modbus or M-bus communication
- Multi-tariffs available(RTC)

Introduction

The SDM530 100A series measure and display the characteristics of three phase four wires(3p4w) supplies, including voltage, frequency, current, power, active and reactive energy, imported or exported. Energy is measured in terms of kWh, kVarh. Maximum demand current can be measured over preset periods of up to 60 minutes. In order to measure energy, the unit requires voltage and current inputs in order to the supply required to power the product.

SDM530 100A series support max.100A direct connection, save the cost and avoid the trouble to connect external CTs, giving the unit a cost-effective and easy operation. Built-in interfaces provide pulse and RS485 Modbus RTU outputs/ Mbus Port. All the configuration are password protected.

Specification	
Nominal voltage(Un)	3x230/400V ac
Operational voltage	80%~120% of Un
Insulation capabilities	
- AC voltage withstand	4KV for 1 minute
- Impulse voltage withstand	6KV-1.2μs
Basic current (Ib)	10A
Maximum rated current (Imax)	100A
Operational current range	0.4% Ib-Imax
Over current withstand	30 Imax for 0.01s
Operational frequency range	50 or 60Hz
Power consumption per phase	≤ 2W/10VA
Display	LCD
Max reading	999999.99 kWh/kVarh

Performance criteria	
Operating humidity	≤ 90%
Storage humidity	≤ 95%
Operating temperature	-25°C - +55°C
Storage temperature	-40°C - +70°C
Reference temperature	23°C± 2°C
International standard	IEC 62053-21 / IEC 62053-22 / EN50470-1/3
Accuracy class	Class1/Class0.5S/Class B
Installation category	CAT III
Mechanical environment	M1
Electromagnetic environment	E2
Degree of pollution	2
Protection against penetration of dust and water	IP51(indoor)
Insulating encased meter of protective class	II
Electrostatic discharges	8kV contact / 15kV air gap
Electromagnetic HF fields	IEC 61000-4-3
Electrical fast transients	4kV

Multi-tariff	
time clock accuracy	< 1s/day
Tariff	4
Time segments	10

Accuracy	
Voltage,Current	0.5%
Frequency	0.2% of mid-frequency
Power factor	1% of unity (0.01)
Active power , Apparent power	±1% of range maximum
Reactive power	±1% of range maximum
Reactive energy(Varh)	Class 2
Active energy (Wh)	Class 1/Class0.5s

Modbus	
Bus type	RS485(semi-duplex)
Protocol	Modbus RTU
Baud rate	1200/2400/4800/9600bps
Address range	1-247
Max. Bus loading	64pcs
Communication distance	1000M
Parity	EVEN/ODD/NONE
Data bit	8
Stop bit	1

M-bus	
Bus type	M-bus
Protocol	EN13757-3
Baud rate	600/1200/2400/4800/9600bps
Parity	NONE/EVEN/ODD
Stop bits	1 or 2
Primary Address	1 to 250
Secondary Address	00 00 00 01 to 99 99 99 99

Pulse Output	
Pulse outputs	2
Pulse output type	Passive
Pulse Output 1	Configurable
Pulse width	200/100(default)/60ms
Pulse output 2	400imp/kWh

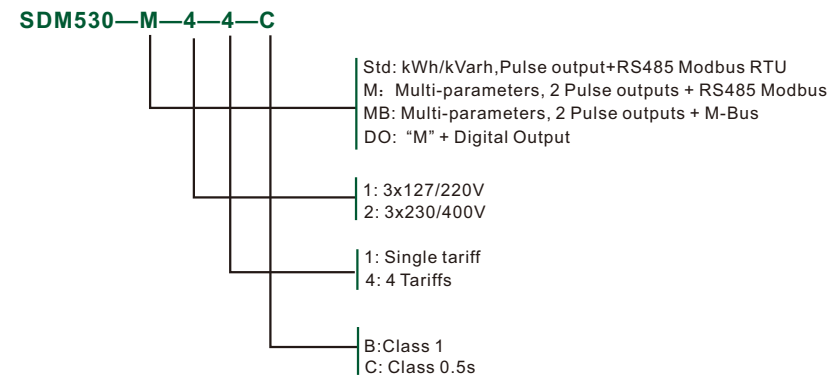

Wiring diagram

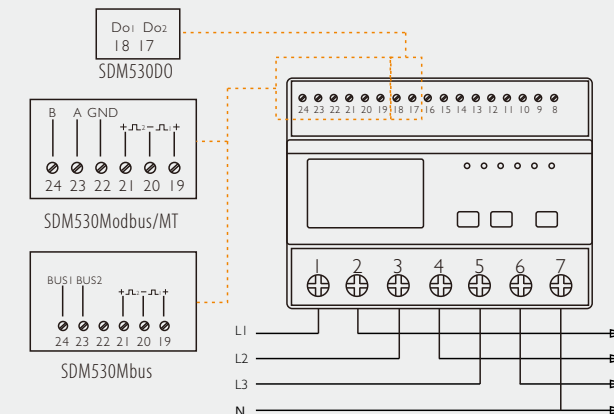

Dimensions

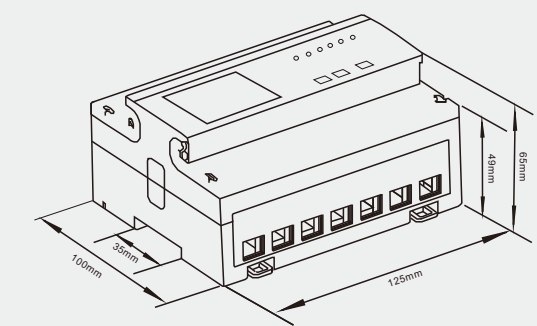

Height 100mm
Width 125mm
Depth 65mm



SDM530CT Modbus / Mbus / MT / DO

THREE PHASE FOUR WIRE MULTI-FUNCTION ENERGY METER

- 5A CT operated
- 7 Module wide
- Multi-measurement:kWh,kVarh,W,Var,VA,PF,HZ,dmd,V,A,etc.
- Bi-directional measurement
- 2 Pulse outputs
- RS485 Modbus or M-bus communication
- Multi-tariffs available(RTC)

Introduction

The SDM530 CT series measure and display the characteristics of three phase four wires(3p4w) supplies, including voltage, frequency, current, power, active and reactive energy, imported or exported. Energy is measured in terms of kWh, kVarh. Maximum demand current can be measured over preset periods of up to 60 minutes. In order to measure energy,the unit requires voltage and current inputs in addition to the supply required to power the product

SDM530CT series can be configured to work with a wide range of CTs, giving the unit a wide range of operation. Built-in interfaces provides pulse and RS485 Modbus or Mbus.Configuration is password protected.



SDM530CT-M-4-4-C

- Std: kWh/kVarh,Pulse output+RS485 Modbus RTU
- M: Multi-parameters, 2 Pulse outputs + RS485 Modbus RTU
- MB: Multi-parameters, 2 Pulse outputs + M-Bus Communication
- DO: "M" + Digital Output
- 1: 127/220V
- 2: 230/400V
- 1: Single tariff
- 4: 4 Tariffs
- B: Class 1
- C: Class 0.5s

Specification	
Nominal voltage(Un)	3x230/400V ac
Operational voltage	80%~120% of Un
Insulation capabilities	
- AC voltage withstand	4KV for 1 minute
- Impulse voltage withstand	6KV-1.2μS
Basic current (Ib)	5A
Maximum rated current (Imax)	100A
Operational current range	0.4% Ib-Imax
Over current withstand	20 Imax for 0.01s
Operational frequency range	50 or 60Hz
Power consumption per phase	≤ 2W/10VA
Display	LCD
Max reading	99999999 kWh/kVarh

Performance criteria	
Operating humidity	≤ 90%
Storage humidity	≤ 95%
Operating temperature	-25°C - +55°C
Storage temperature	-40°C - +70°C
Reference temperature	23°C± 2°C
International standard	IEC 62053-21 / IEC 62053-22/ EN50470-1/3
Accuracy class	Class1/Class0.5S/Class B
Installation category	CAT III
Mechanical environment	M1
Electromagnetic environment	E2
Degree of pollution	2
Protection against penetration of dust and water	IP51(indoor)
Insulating encased meter of protective class	II
Electrostatic discharges	8kV contact / 15kV air gap
Electromagnetic HF fields	IEC 61000-4-3
Electrical fast transients	4kV

Multi-tariff	
time clock accuracy	< 1s/day
Tariff	4
Time segments	10

Accuracy	
Voltage,Current	0.5%
Frequency	0.2% of mid-frequency
Power factor	1% of unity (0.01)
Active power , Apparent power	±1% of range maximum
Reactive power	±1% of range maximum
Reactive energy(Varh)	Class 2
Active energy (Wh)	Class 1/Class0.5S

Modbus	
Bus type	RS485(semi-duplex)
Protocol	Modbus RTU
Baud rate	1200/2400/4800/9600bps
Address range	1-247
Max. Bus loading	64pcs
Communication distance	1000M
Parity	EVEN/ODD/NONE
Data bit	8
Stop bit	1

M-bus	
Bus type	M-bus
Protocol	EN13757-3
Baud rate	600/1200/2400/4800/9600bps
Parity	NONE/EVEN/ODD
Stop bits	1 or 2
Primary Address	1 to 250
Secondary Address	00 00 00 01 to 99 99 99 99

Pulse Output	
Pulse outputs	2
Pulse output type	Passive
Pulse Output 1	Configurable
Pulse width	200/100(default)/60ms
Pulse output 2	1000imp/kWh

Wiring diagram

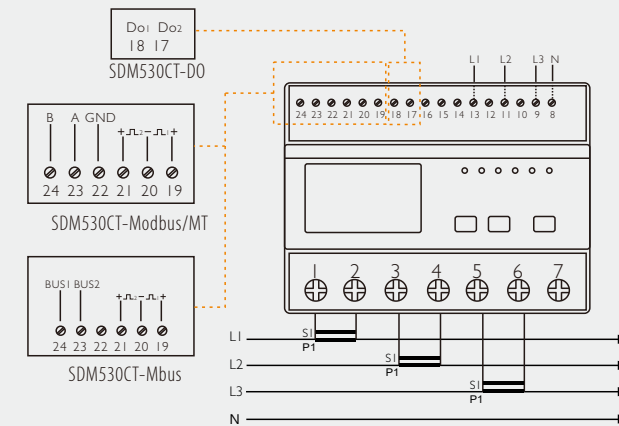

Dimensions

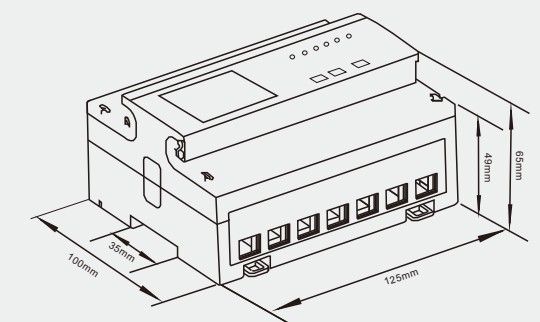

Height 100mm
Width 125mm
Depth 65mm



SDM630 Modbus / Mbus / MT / Std / Pulse/2T

THREE PHASE MULTI-FUNCTION ENERGY METER

- 100A direct load
- Works with 3P4W / 3P3W / 1P2W
- 4 Module wide
- Multi-measurement:kWh,kVarh,W,Var,VA,PF,Hz,dmd,V,A,THD,etc.
- Bi-directional measurement
- 2 Pulse outputs
- RS485 Modbus or M-bus communication
- Multi-tariffs available(RTC)
- 2 Tariffs available(dual power source)



Introduction

The SDM630 100A series are three phase multifunction DIN rail meter. It can measure and display the characteristic of 1p2w,3p3w and 3p4w supplies, including voltage, current, power, active and reactive energy imported or exported. Energy is measured in terms of kWh, kVarh. Max demand current can be measured over preset periods of up to 60 minutes. The SDM630 100A series has wonderful industrial design, big size LCD and touch buttons. All electronic parameters can be set with the button and the configuration is password protected. It can directly connect to max. 100A saving the cost to install external CT. Built-in interfaces provides pulse and RS485 Modbus RTU outputs.

SDM630 Series have been assessed and certified as meeting the requirements of EU Directive 2014/32/EU. The instrument traceable number is 0120/SGS0151

Specification	
Nominal voltage(Un)	3x230/400V ac
Operational voltage	80%~120% of Un
Insulation capabilities	
- AC voltage withstand	4KV for 1 minute
- Impulse voltage withstand	6KV-1.2μS
Basic current (Ib)	10A
Maximum rated current (Imax)	100A
Operational current range	0.4% Ib-Imax
Over current withstand	30 Imax for 0.01s
Operational frequency range	50 or 60Hz
Power consumption per phase	≤ 2W/10VA
Display	LCD
Max reading	999999.99 kWh/kVarh

Performance criteria	
Operating humidity	≤ 90%
Storage humidity	≤ 95%
Operating temperature	-25°C - +55°C
Storage temperature	-40°C - +70°C
Reference temperature	23°C± 2°C
International standard	IEC 62053-21 / IEC 62053-22 / EN50470-1/3
Accuracy class	Class1/Class0.5S/Class B
Installation category	CAT III
Mechanical environment	M1
Electromagnetic environment	E2
Degree of pollution	2
Protection against penetration of dust and water	IP51(indoor)
Insulating encased meter of protective class	II
Electrostatic discharges	8kV contact / 15kV air gap
Electromagnetic HF fields	IEC 61000-4-3
Electrical fast transients	4kV

Multi-tariff	
time clock accuracy	< 1s/day
Tariff	4
Time segments	10

Accuracy	
Voltage,Current	0.5%
Frequency	0.2% of mid-frequency
Power factor	1% of unity (0.01)
Active power , Apparent power	±1% of range maximum
Reactive power	±1% of range maximum
Reactive energy(Varh)	Class 2
Active energy (Wh)	Class 1/Class0.5S

Modbus	
Bus type	RS485(semi-duplex)
Protocol	Modbus RTU
Baud rate	2400/4800/9600/19200/38400bps
Address range	1-247
Max. Bus loading	64pcs
Communication distance	1000M
Parity	EVEN/ODD/NONE
Data bit	8
Stop bit	1

M-bus	
Bus type	M-bus
Protocol	EN13757-3
Baud rate	600/1200/2400/4800/9600bps
Parity	NONE/EVEN/ODD
Stop bits	1 or 2
Primary Address	1 to 250
Secondary Address	00 00 00 01 to 99 99 99 99

Pulse Output	
Pulse outputs	2
Pulse output type	Passive
Pulse Output 1	Configurable
Pulse width	200/100(default)/60ms
Pulse output 2	400imp/kWh

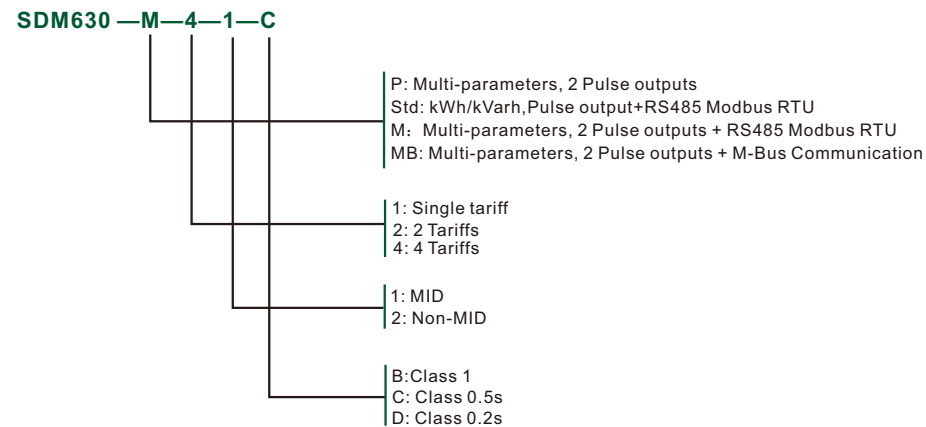
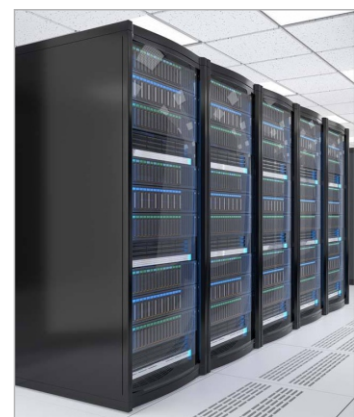

Wiring diagram

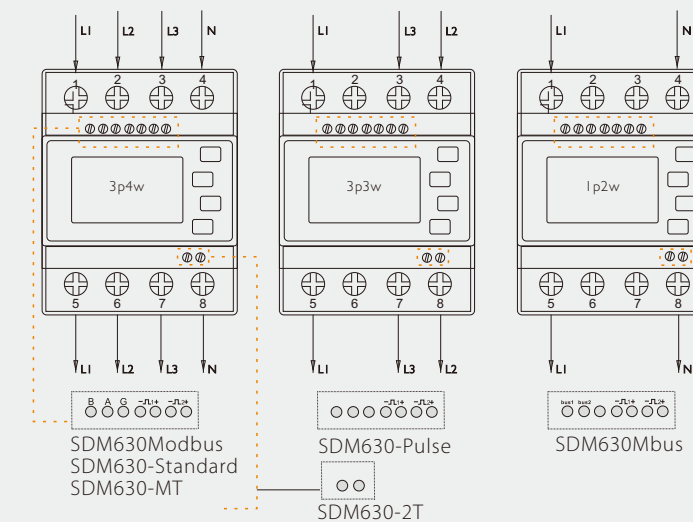

Dimensions

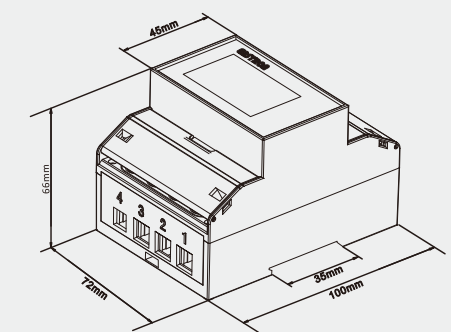

Height 100mm
Width 72mm
Depth 66mm



SDM630MCT Modbus/Mbus/2T/MV

THREE PHASE MULTI-FUNCTION ENERGY METER

- CT & PT operated
- Works with 3P4W / 3P3W / 1P2W
- 4 Module wide
- Multi-measurement:kWh,kVarh,W,Var,VA,PF,HZ,dmd,V,A,THD,etc.
- Bi-directional measurement
- 2 Pulse outputs
- RS485 Modbus or M-bus communication
- 2 Tariffs available(dual power source)



Introduction

The SDM630M CT Series is a three phase multifunction DIN rail meter. It can measure and display the characteristic of 1p2w, 3p3w and 3p4w supplies, including voltage, current, power, active and reactive energy imported or exported. Energy is measured in terms of kWh, kVarh. Max demand current can be measured over preset periods of up to 60 minutes. In order to measure energy, the unit requires voltage and current inputs in addition to the supply required to the power the meter. The required current inputs are obtained via current transformers. This meter can be configurable to work with a wide range of CTs, giving the unit a wide range of operation. Build-in interface provides pulse and RS485 Modbus RTU or Mbus outputs. And the configuration is password protected.

SDM630 CT Series have been assessed and certified as meeting the requirements of EU Directive 2014/32/EU. The instrument traceable number is 0120/SGS0142

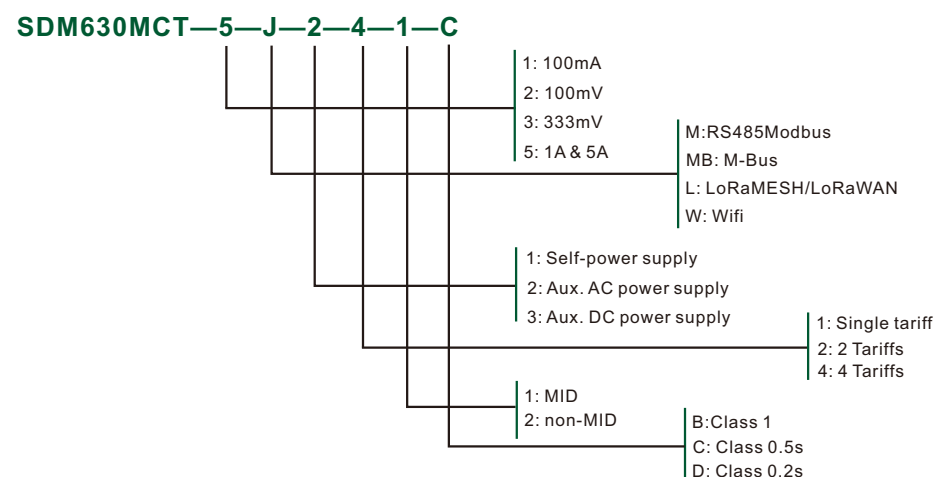
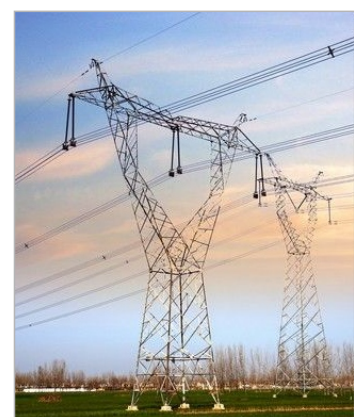

Specification	
Nominal voltage(Un)	3x230/400V ac
Operational voltage	60%~120% of Un
Insulation capabilities	
- AC voltage withstand	4KV for 1 minute
- Impulse voltage withstand	6KV-1.2μS
Rated current (Ib)	5A CT or 333mV CT input/100mA
Operational current range	0.4% Ib-Imax
Over current withstand	20 Imax for 0.01s
Operational frequency range	50 or 60Hz
Power consumption per phase	≤ 2W/10VA
Pulse output 1	Configurable
Pulse output 2	3200 imp/kWh
Display	LCD
Max reading	9999999.9 kWh/kVarh

Performance criteria	
Operating humidity	≤ 90%
Storage humidity	≤ 95%
Operating temperature	-25°C - +55°C
Storage temperature	-40°C - +70°C
Reference temperature	23°C± 2°C
International standard	IEC 62053-21/IEC 62053-22/ EN50470-1/3
Accuracy class	Class1/Class0.5S/Class B
Installation category	CAT III
Mechanical environment	M1
Electromagnetic environment	E2
Degree of pollution	2
Protection against penetration of dust and water	IP51(indoor)
Insulating encased meter of protective class	II
Electrostatic discharges	8kV contact / 15kV air gap
Radiated & conducted emissions	EN 55022

Accuracy	
Voltage,Current	0.5%
Frequency	0.2% of mid-frequency
Power factor	1% of unity (0.01)
Active power , Apparent power	±1% of range maximum
Reactive power	±1% of range maximum
Reactive energy(Varh)	Class 2
Active energy (Wh)	Class 1/Class0.5S

Modbus	
Bus type	RS485(semi-duplex)
Protocol	Modbus RTU
Baud rate	2400/4800/9600/19200/38400bps
Address range	1-247
Max. Bus loading	64pcs
Communication distance	1000M
Parity	EVEN/ODD/NONE
Data bit	8
Stop bit	1

M-bus	
Bus type	M-bus
Protocol	EN13757-3
Baud rate	600/1200/2400/4800/9600bps
Parity	NONE/EVEN/ODD
Stop bits	1 or 2
Primary Address	1 to 250
Secondary Address	00 00 00 01 to 99 99 99 99

Wiring diagram

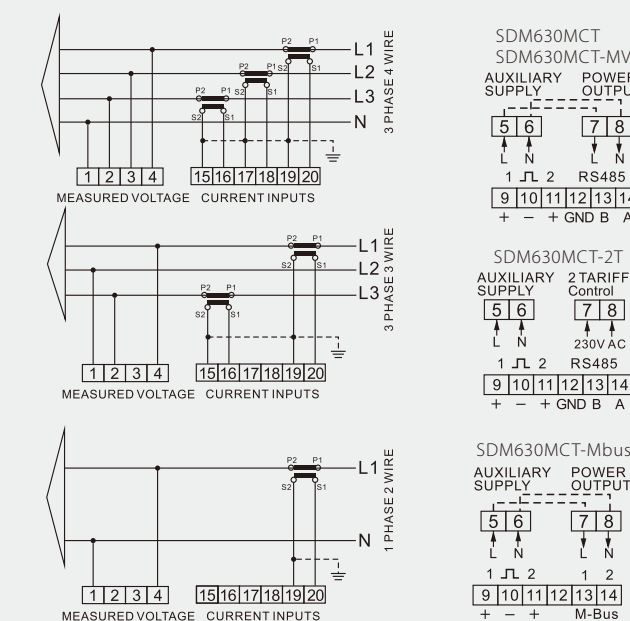

Dimensions

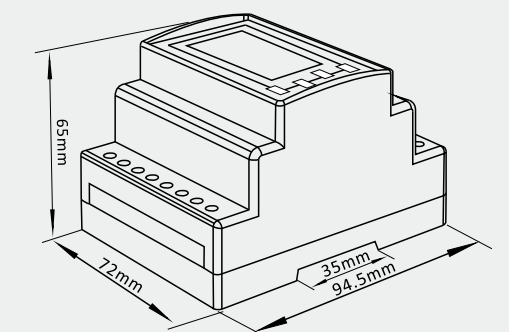

Height 94.5mm
 Width 72mm
 Depth 65mm



SDM630MCT-RJ/2L

THREE PHASE FOUR WIRE MULTI-FUNCTION ENERGY METER

- CT operated
- Plug-in connection
- RJ12 100mA/333mV current input
- Multi-parameter measured
- THD of voltage and current
- RS485 Modbus
- 2 Pulse outputs

Introduction

The SDM630MCT-RJ/2L is a three phase 4 wire multi-function energy meter. It measures and displays the characteristic of 3p4w network, including voltage, current, power, active and reactive energy imported and exported, THD, power demand, frequency, power factor etc. The meter uses plug-in terminals for both voltage input and current input. With 3-in-1 Current Transformer (ESCT-RJ), the meter provides an easy, quick and error-free connection solution. Equipped with RS485 communication port and 2 pulse outputs, the meter is an ideal product for sub-metering in low voltage application.

Specification	
Nominal voltage(Un)	3x230/400V ac
Operational voltage	60%~120% of Un
Insulation capabilities	
- AC voltage withstand	4KV for 1 minute
- Impulse voltage withstand	6KV-1.2μS
Rated current (Ib)	100mA or 333mV CT input
Operational current range	0.4% Ib-Imax
Over current withstand	20 I _{max} for 0.01s
Operational frequency range	50 or 60Hz
Power consumption per phase	≤ 2W/10VA
Pulse output 1	Configurable
Pulse output 2	3200 imp/kWh
Display	LCD
Max reading	9999999.9 kWh/kVarh

Performance criteria	
Operating humidity	≤ 90%
Storage humidity	≤ 95%
Operating temperature	-25°C - +55°C
Storage temperature	-40°C - +70°C
Reference temperature	23°C± 2°C
International standard	IEC 62053-21 / IEC 62053-22 / EN50470-1/3
Accuracy class	Class1/Class0.5S/Class B
Installation category	CAT III
Mechanical environment	M1
Electromagnetic environment	E2
Degree of pollution	2
Protection against penetration of dust and water	IP51(indoor)
Insulating encased meter of protective class	II
Electrostatic discharges	8kV contact / 15kV air gap
Radiated & conducted emissions	EN 55022

Accuracy	
Voltage,Current	0.5%
Frequency	0.2% of mid-frequency
Power factor	1% of unity (0.01)
Active power, Apparent power	±1% of range maximum
Reactive power	±1% of range maximum
Reactive energy(Varh)	Class 2
Active energy (Wh)	Class 1/Class0.5S

Modbus	
Bus type	RS485(semi-duplex)
Protocol	Modbus RTU
Baud rate	2400/4800/9600/19200/38400bps
Address range	1-247
Max. Bus loading	64pcs
Communication distance	1000M
Parity	EVEN/ODD/NONE
Data bit	8
Stop bit	1

M-bus (Optional)	
Bus type	M-bus
Protocol	EN13757-3
Baud rate	600/1200/2400/4800/9600bps
Parity	NONE/EVEN/ODD
Stop bits	1 or 2
Primary Address	1 to 250
Secondary Address	00 00 00 01 to 99 99 99 99

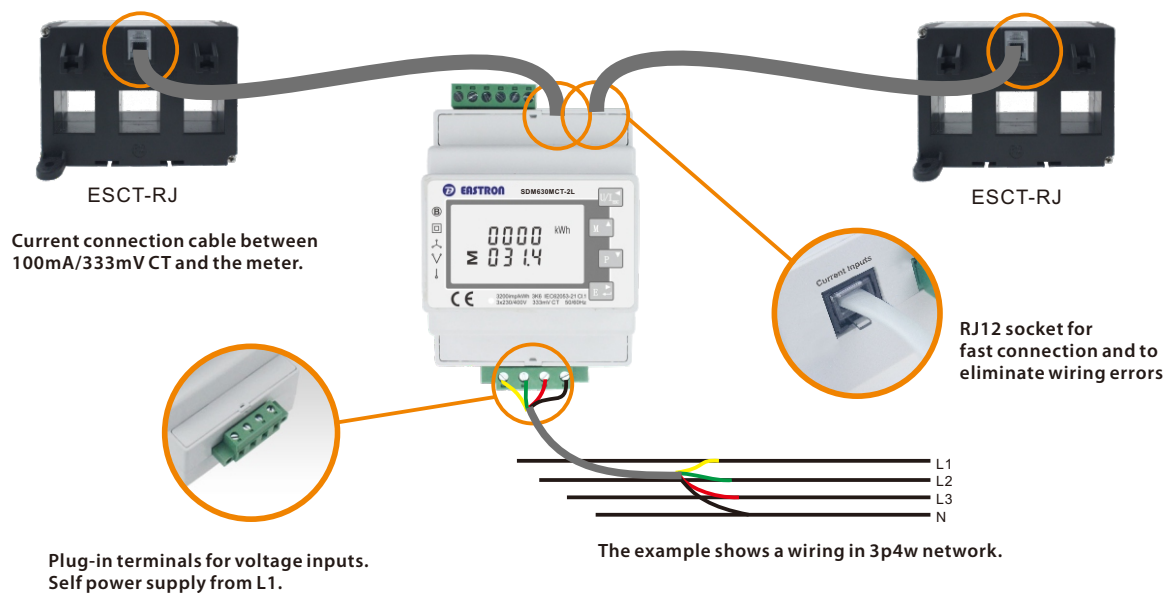

Wiring diagram

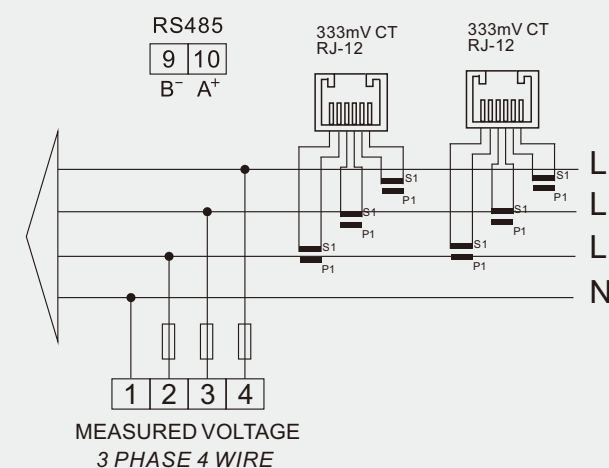

Dimensions

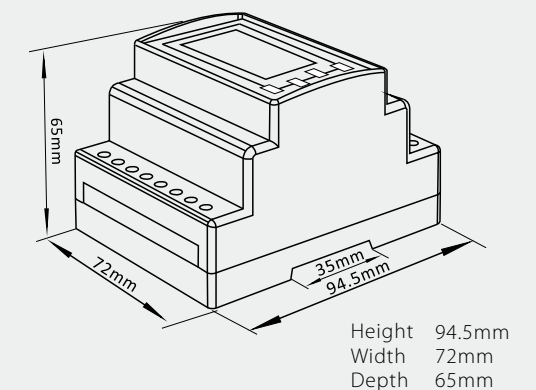



SDM630-2C

DUAL LOAD MULTI-FUNCTION ENERGY METER

- 2 Meters in 1
- Easy and error free connection
- 5A / 333mV CT input
- Multi-parameter measured
- RS485 Modbus RTU
- 2 Pulse outputs

Introduction

The SDM630-2C is a dual load three phase 4 wire multi-function energy meter for measuring energy consumption in split load applications such as Power and lighting loads. The meter measures 2 three phase circuits separately and display the parameters including voltage, current, power, power factor, frequency, demand, active energy, reactive energy etc.

The meter connects with 3-in-1 CT via wiring looms for plug-in connection. It is a cost-effective and space saving solution for all new power and lighting, or dual load, distribution and panel boards. ESCT-SC series current transformer provides a range of CT with primary current up to 630A.

DUAL LOAD SOLUTION

Three phase 3-in-1 Current Transformer with plug-in terminal and wiring looms for quick and error-free installation.

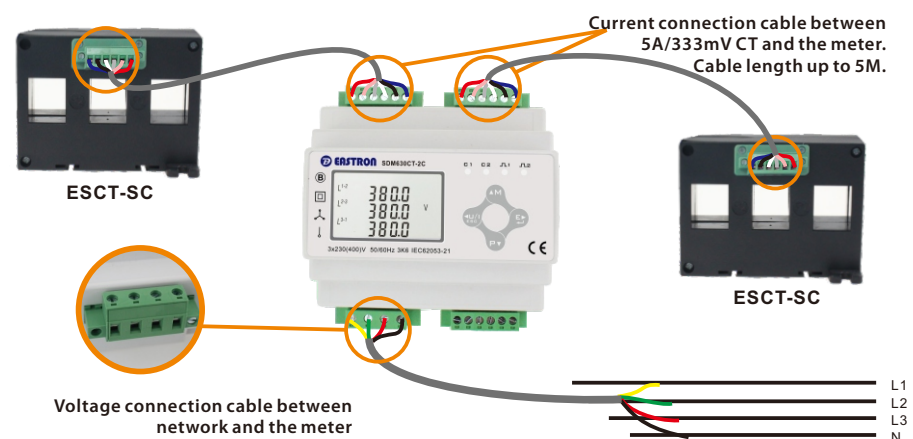

Specification	
Nominal voltage(Un)	3x230/400V ac
Operational voltage	80%~120% of Un
Insulation capabilities	
- AC voltage withstand	4KV for 1 minute
- Impulse voltage withstand	6KV-1.2μs
Rated current (Ir)	5A or 333mV CT input
Operational current range	0.4% Ib-I _{max}
Over current withstand	20 I _{max} for 0.01s
Operational frequency range	50 or 60Hz
Power consumption per phase	≤ 2W/10VA
Pulse output	Configurable
Display	LCD
Max reading	9999999.9 kWh/kVarh

Performance criteria	
Operating humidity	≤ 90%
Storage humidity	≤ 95%
Operating temperature	-25°C - +55°C
Storage temperature	-40°C - +70°C
Reference temperature	23°C± 2°C
International standard	IEC 62053-21 / IEC 62053-22 / EN50470-1/3
Accuracy class	Class1/Class0.5S/Class B
Installation category	CAT III
Mechanical environment	M1
Electromagnetic environment	E2
Degree of pollution	2
Protection against penetration of dust and water	IP51(indoor)
Insulating encased meter of protective class	II
Electrostatic discharges	8kV contact / 15kV air gap
Electromagnetic HF fields	IEC 61000-4-3
Electrical fast transients	4kV
Surge	4kV
Radiated & conducted emissions	EN 55022

Accuracy	
Voltage,Current	0.5%
Frequency	0.2% of mid-frequency
Power factor	1% of unity (0.01)
Active power, Apparent power	±1% of range maximum
Reactive power	±1% of range maximum
Reactive energy(Varh)	Class 2
Active energy (Wh)	Class 1/Class0.5S

Modbus	
Bus type	RS485(semi-duplex)
Protocol	Modbus RTU
Baud rate	2400/4800/9600/19200/38400 bps
Address range	1-247
Max. Bus loading	64pcs
Communication distance	1000M
Parity	EVEN/ODD/NONE
Data bit	8
Stop bit	1

Pulse Output	
Pulse outputs	2
Pulse output type	Passive
Pulse Output 1	C1 Configurable
Pulse output 2	C2 Configurable
Pulse width	200/100(default)/60ms

Wiring diagram

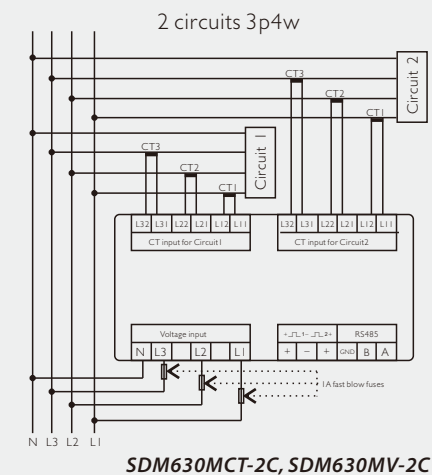

Dimensions

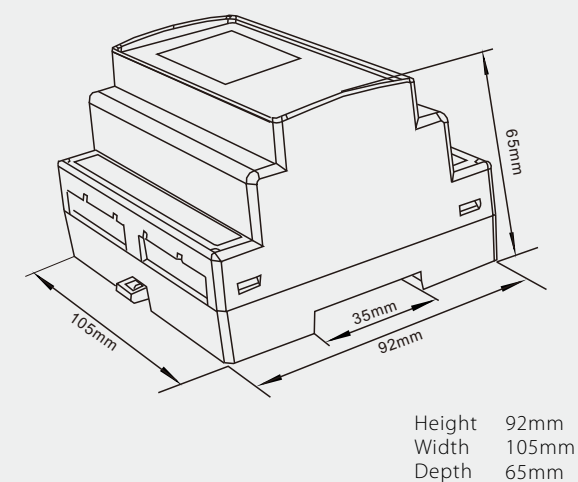



SDM120 A/D/DB
SINGLE PHASE TWO WIRE KWH METER

- 45A Max. direct load
- 1 module wide
- Active energy measured
- Pulse output
- Din rail mounted



SDM 230A/D
SINGLE PHASE TWO WIRE KWH METER

- 100A Max. direct load
- 2 module wide
- Active energy measured
- Pulse output
- Din rail mounted

Specification	
Model	SDM120A/120D/120DB
Display	SDM120A electromechanical register
	SDM120D LCD
	SDM120DB LCD with Backlit
Nominal voltage(Un)	120V or 230V ac
Operational voltage	80%~120% of Un
Insulation capabilities	
- AC voltage withstand	4KV for 1 minute
- Impulse voltage withstand	6KV-1.2μS
Basic current (Ib)	5A
Maximum rated current (Imax)	45A
Operational current range	0.4% Ib-Imax
Over current withstand	30 Imax for 0.01s
Operational frequency range	50 / 60Hz
Internal power consumption	≤ 2W/10VA
Pulse output	1000imp/kWh
Max reading	99999.9 kWh

Performance criteria	
Operating humidity	≤ 90%
Storage humidity	≤ 95%
Operating temperature	-25°C - +55°C
Storage temperature	-40°C - +70°C
Reference temperature	23°C±2°C
International standard	IEC 62053-21 / EN50470-1/3
Accuracy class	Class1/Class B
Installation category	CAT II
Mechanical environment	M1
Electromagnetic environment	E2
Degree of pollution	2
Protection against penetration of dust and water	IP51(indoor)
Insulating encased meter of protective class	II
Electrostatic discharges	8kV contact / 15kV air gap
Electromagnetic HF fields	IEC 61000-4-3
Electrical fast transients	4kV
Surge	4kV
Radiated & conducted emissions	EN 55022



The SDM120 A/D/DB series provides an uni-direction (anti-reverse) measurement model. It would only count the forward energy, and not count the reverse energy. It is widely used in solar generation energy measurement.

► Description

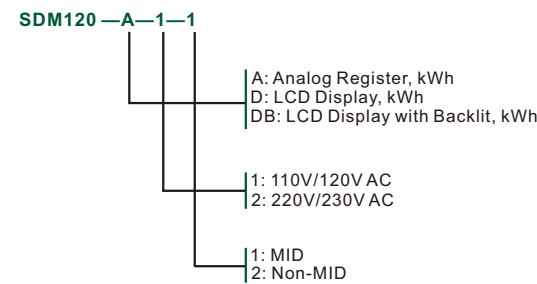

► Wiring diagrams

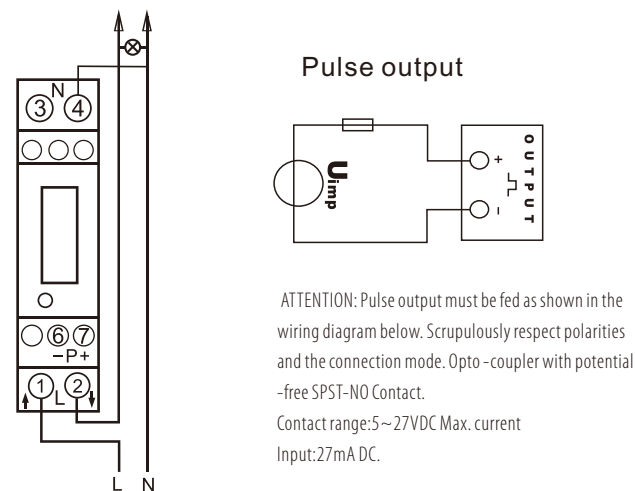

► Dimensions

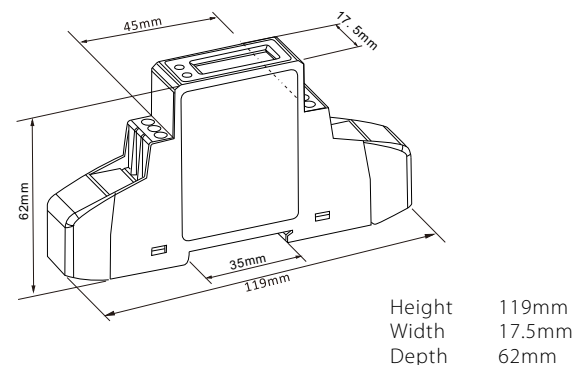

Specification	
Model	SDM 230A /SDM230D
Display	SDM230A electromechanical register
	SDM230D LCD
Nominal voltage(Un)	120V or 230V ac
Operational voltage	80%~120% of Un
Insulation capabilities	
- AC voltage withstand	4KV for 1 minute
- Impulse voltage withstand	6KV-1.2μS
Basic current (Ib)	10A
Maximum rated current (Imax)	100A
Operational current range	0.4% Ib-Imax
Over current withstand	30 Imax for 0.01s
Operational frequency range	50 or 60Hz
Internal power consumption	≤ 2W/10VA
Pulse output	1000imp/kWh
Max reading	999999.9 kWh(SDM230A) 99999.9 kWh(SDM230D)

Performance criteria	
Operating humidity	≤ 90%
Storage humidity	≤ 95%
Operating temperature	-25°C - +55°C
Storage temperature	-40°C - +70°C
Reference temperature	23°C±2°C
International standard	IEC 62053-21 / EN50470-1/3
Accuracy class	Class1/Class B
Installation category	CAT II
Mechanical environment	M1
Electromagnetic environment	E2
Degree of pollution	2
Protection against penetration of dust and water	IP51 (indoor)
Insulating encased meter of protective class	II
Aititude	up to 2000m
Electrostatic discharges	8kV contact / 15kV air gap
Electromagnetic HF fields	IEC 61000-4-3
Electrical fast transients	4kV
Surge	4kV
Radiated & conducted emissions	EN 55022

Mechanics	
Din rail dimensions	99x36x63 (HxWxD) DIN 43880
Mounting DIN rail	35mm
Sealing	IP51 (indoor)
Material	self-extinguishing UL94V-0

► Description

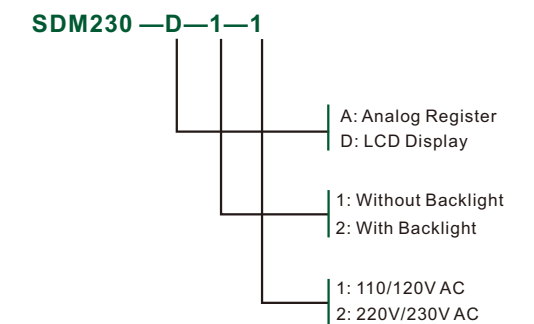

► Wiring diagrams

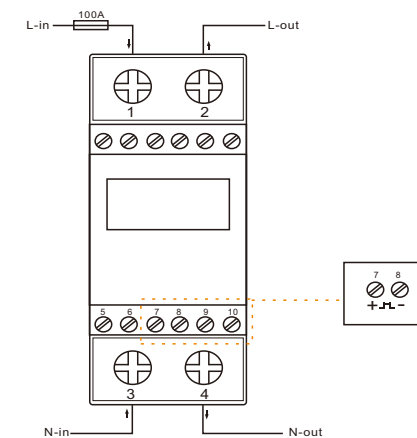

► Dimensions

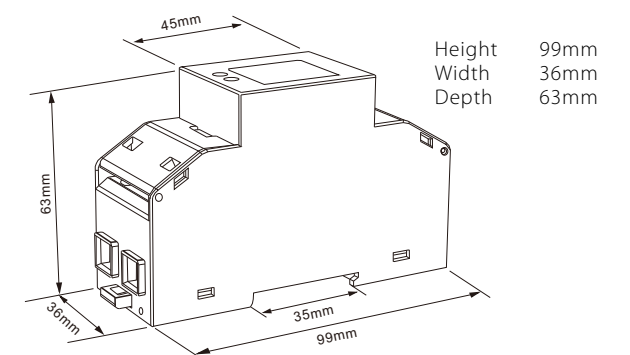



SDM 230DR/BI

SINGLE PHASE TWO WIRE KWH METER

- 100A Max. direct load
- Active energy + power measured
- Resettable energy
- Pulse output
- Din rail mounted



SDM320Y/D

SINGLE PHASE TWO WIRE KWH METER

- 100A Max. direct load
- 4 Module wide
- Active energy measured
- Pulse output
- IEC62053-21 Class 1

Specification	
Model	SDM 230DR / SDM230BI
Display	LCD with Backlit
Nominal voltage(Un)	120V or 230V ac
Operational voltage	80%~120% of Un
Insulation capabilities	
- AC voltage withstand	4KV for 1 minute
- Impulse voltage withstand	6KV-1.2μS
Basic current (Ib)	10A
Maximum rated current (Imax)	100A
Operational current range	0.4% Ib-Imax
Over current withstand	30 Imax for 0.01s
Operational frequency range	50 or 60Hz
Internal power consumption	≤ 2W/10VA
Pulse output 1	1000imp/kWh
Pulse output 2	1000imp/kWh
Max reading	999999.9 kWh

Performance criteria	
Operating humidity	≤ 90%
Storage humidity	≤ 95%
Operating temperature	-25°C - +55°C
Storage temperature	-40°C - +70°C
Reference temperature	23°C ± 2°C
International standard	IEC 62053-21 / EN50470-1/3
Accuracy class	Class1/Class B
Installation category	CAT II
Mechanical environment	M1
Electromagnetic environment	E2
Degree of pollution	2
Protection against penetration of dust and water	IP51 (indoor)
Insulating encased meter of protective class	II
Electrostatic discharges	8kV contact / 15kV air gap
Electromagnetic HF fields	IEC 61000-4-3
Electrical fast transients	4kV
Surge	4kV
Radiated & conducted emissions	EN 55022

MECHANICS	
Din rail dimensions	99x36x63 (HxHxD) DIN 43880
Mounting DIN rail	35mm
Sealing	IP51 (indoor)
Material	self-extinguishing UL94V-0

Description Buttons

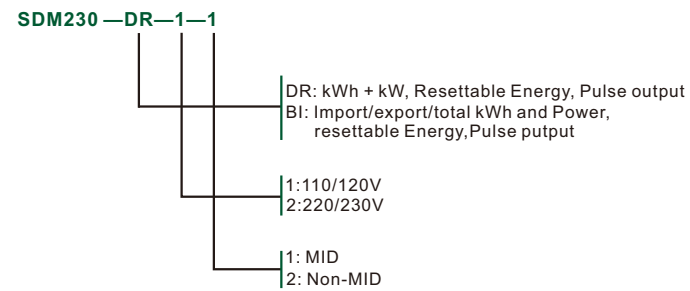

Wiring diagrams

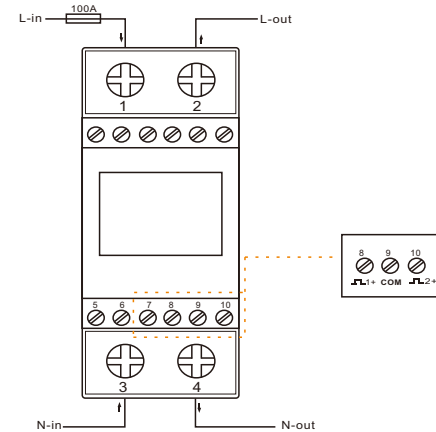

Dimensions

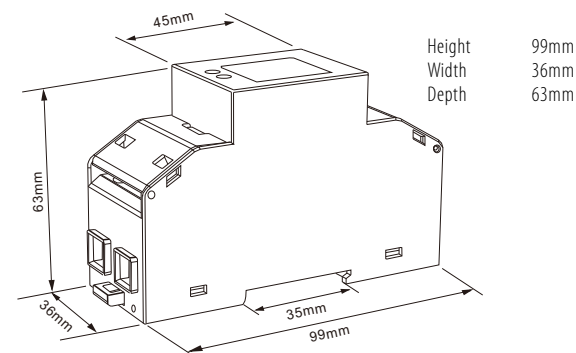

Specification	
Model	SDM320Y/320D
Nominal voltage(Un)	230V or 120V ac
Operational voltage	80%~120% of Un
Insulation capabilities	
- AC voltage withstand	4KV for 1 minute
- Impulse voltage withstand	6KV-1.2μS
Basic current (Ib)	10A
Maximum rated current (Imax)	80A
Operational current range	0.4% Ib-Imax
Over current withstand	30 Imax for 0.01s
Operational frequency range	50 or 60Hz
Internal power consumption	≤ 2W/10VA
Pulse output	1000imp/kWh
Display	LCD
Max reading	99999.99 kWh

Performance criteria	
Operating humidity	≤ 90%
Storage humidity	≤ 95%
Operating temperature	-25°C - +55°C
Storage temperature	-40°C - +70°C
Reference temperature	23°C ± 2°C
International standard	IEC 62053-21 / EN50470-1/3
Accuracy class	Class1/Class B
Installation category	CAT II
Mechanical environment	M1
Electromagnetic environment	E2
Degree of pollution	2
Protection against penetration of dust and water	IP51 (indoor)
Insulating encased meter of protective class	II
Altitude	up to 2000m
Electrostatic discharges	8kV contact / 15kV air gap
Electromagnetic HF fields	IEC 61000-4-3
Electrical fast transients	4kV
Surge	4kV
Radiated & conducted emissions	EN 55022

MECHANICS	
Din rail dimensions	76x100x66 (WxHxD) DIN 43880
Mounting DIN rail	35mm
Sealing	IP51 (indoor)
Material	self-extinguishing UL94V-0

Description

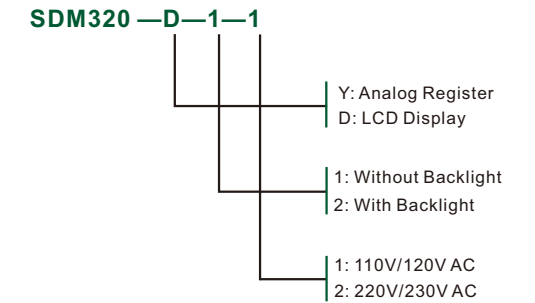

Wiring diagrams

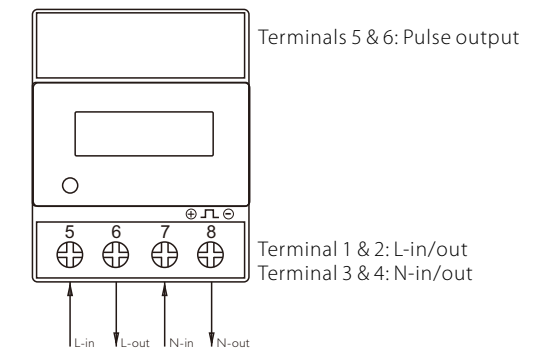

Dimensions

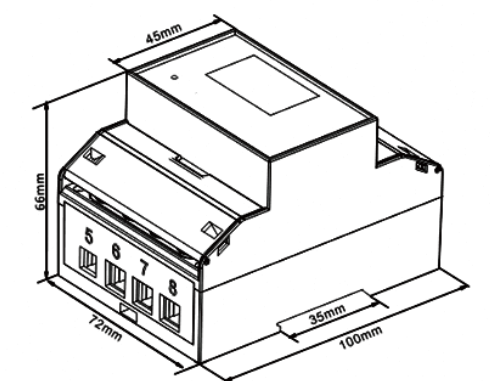

Height 100mm
Width 72mm
Depth 66mm



SDM320E
SINGLE PHASE THREE WIRE KWH METER

- 100A MAX. direct load
- 4 Module wide
- Active energy measured
- Pulse output
- IEC62053-21 Class 1



SDM530D/D-2T
THREE PHASE FOUR WIRE KWH METER

- 100A MAX. direct load
- 7 Module wide
- Active energy measured
- IEC62053-21 Class 1
- Pulse output
- 2 Tariffs available

Specification	
Model	SDM320E
Nominal voltage(Un)	110/220V ac or 220/380V ac
Operational voltage	80%~120% of Un
Insulation capabilities	
- AC voltage withstand	4KV for 1 minute
- Impulse voltage withstand	6KV-1.2μs
Basic current (Ib)	10A
Maximum rated current (Imax)	100A
Operational current range	0.4% Ib-Imax
Over current withstand	30 Imax for 0.01s
Operational frequency range	50 or 60Hz
Internal power consumption	≤ 2W/10VA
Pulse output	1600imp/kWh
Display	LCD
Max reading	99999.99 kWh

Performance criteria	
Operating humidity	≤ 90%
Storage humidity	≤ 95%
Operating temperature	-25°C - +55°C
Storage temperature	-40°C - +70°C
Reference temperature	23°C±2°C
International standard	IEC 62053-21 / EN50470-1/3
Accuracy class	Class 1/Class B
Installation category	CAT II
Mechanical environment	M1
Electromagnetic environment	E2
Degree of pollution	2
Protection against penetration of dust and water	IP51 (indoor)
Insulating encased meter of protective class	II
Electrostatic discharges	8kV contact / 15kV air gap
Electromagnetic HF fields	IEC 61000-4-3
Electrical fast transients	4kV
Surge	4kV
Radiated & conducted emissions	EN 55022

Mechanics	
Din rail dimensions	76x100x66 (WxHxD) DIN 43880
Mounting DIN rail	35mm
Sealing	IP51 (indoor)
Material	self-extinguishing UL94V-0

► Description

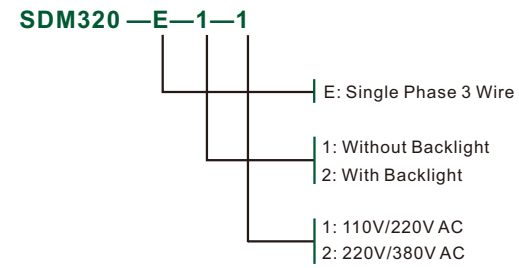

► Wiring diagrams

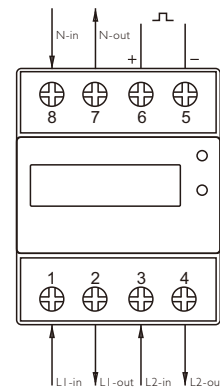

► Dimensions

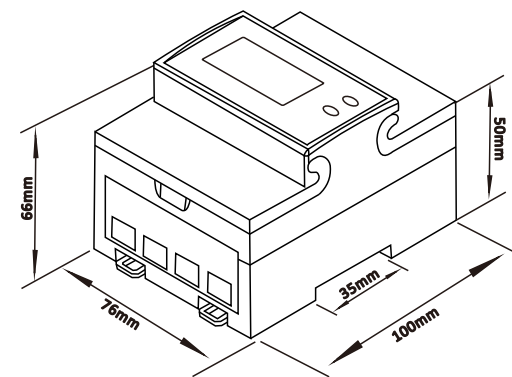

Height 100mm
Width 76mm
Depth 66mm

Specification	
Model	SDM530D / SDM530D-2T
Nominal voltage(Un)	3x230/400V ac or 3x127/220V ac
Operational voltage	80%~120% of Un
Insulation capabilities	
- AC voltage withstand	4KV for 1 minute
- Impulse voltage withstand	6KV-1.2μs
Basic current (Ib)	10A
Maximum rated current (Imax)	100A
Operational current range	0.4% Ib-Imax
Over current withstand	30 Imax for 0.01s
Operational frequency range	50 or 60Hz
Power consumption per phase	≤ 2W/10VA
Pulse output	800imp/kWh
Display	LCD
Max reading	999999.9 kWh

Performance criteria	
Operating humidity	≤ 90%
Storage humidity	≤ 95%
Operating temperature	-25°C - +55°C
Storage temperature	-40°C - +70°C
Reference temperature	23°C±2°C
International standard	IEC 62053-21 / EN50470-1/3
Accuracy class	Class 1/Class B
Installation category	CAT III
Mechanical environment	M1
Electromagnetic environment	E2
Degree of pollution	2
Insulating encased meter of protective class	II
Electrostatic discharges	8kV contact / 15kV air gap
Electromagnetic HF fields	IEC 61000-4-3
Electrical fast transients	4kV
Surge	4kV
Radiated & conducted emissions	EN 55022

Mechanics	
Din rail dimensions	100x125x65 (HxWxD) DIN 43880
Mounting DIN rail	35mm
Sealing	IP51 (indoor)
Material	self-extinguishing UL94V-0

► Description

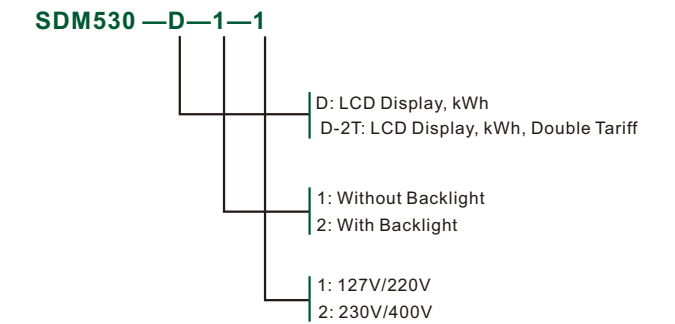

► Wiring diagrams

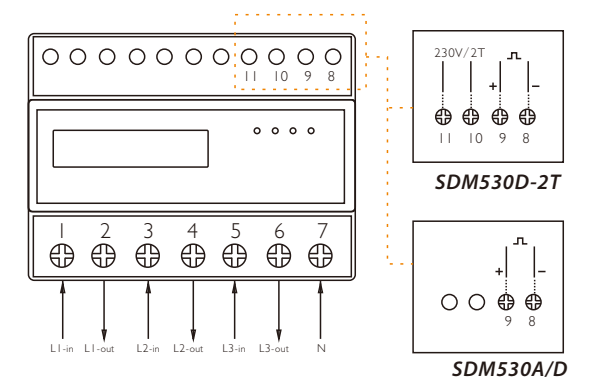

► Dimensions

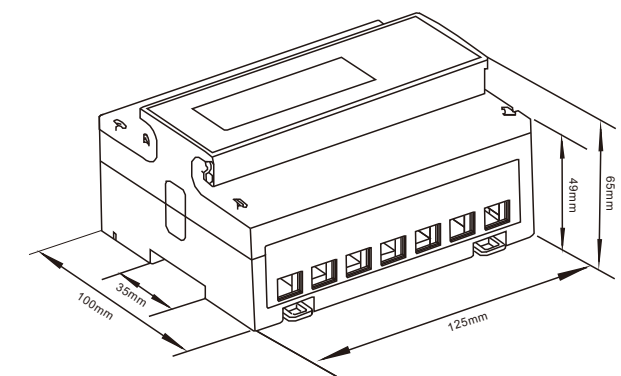

Height 100mm
Width 125mm
Depth 65mm



SDM72D/DR/BI

THREE PHASE FOUR WIRE ENERGY METER

- 100A MAX. direct load
- 4 Module wide
- Measures active energy(kWh)+ power(W)
- Bi-directional measurement
- Resettable energy
- Pulse output



SDM72D-M

THREE PHASE FOUR WIRE ENERGY METER

- 100A MAX. direct load
- 4 Module wide
- Measures active energy(kWh)+ power(W)
- Bi-directional measurement
- Resettable energy
- Rs485 Modbus + Pulse output



Specification	
Model	SDM72D/DR/BI
Nominal voltage(Un)	3x230/400V ac
Operational voltage	80%~120% of Un
Insulation capabilities	
- AC voltage withstand	4KV for 1 minute
- Impulse voltage withstand	6KV-1.2μS
Basic current (Ib)	10A
Maximum rated current (Imax)	100A
Operational current range	0.4% Ib-Imax
Over current withstand	30 Imax for 0.01s
Operational frequency range	50 or 60Hz
Power consumption per phase	≤ 2W/10VA
Pulse output	1000imp/kWh
Display	LCD
Max reading	999999.9 kWh

Performance criteria	
Operating humidity	≤ 90%
Storage humidity	≤ 95%
Operating temperature	-25°C - +55°C
Storage temperature	-40°C - +70°C
Reference temperature	23°C± 2°C
International standard	IEC 62053-21 / EN50470-1/3
Accuracy class	Class1/Class B
Installation category	CAT III
Mechanical environment	M1
Electromagnetic environment	E2
Degree of pollution	2
Protection against penetration of dust and water	IP51(indoor)
Insulating encased meter of protective class	II
Altitude	up to 2000m
Electrostatic discharges	8kV contact / 15kV air gap
Electromagnetic HF fields	IEC 61000-4-3
Electrical fast transients	4kV
Surge	4kV
Radiated & conducted emissions	EN 55022

Mechanics	
Din rail dimensions	72x100x66 (WxHxD) DIN 43880
Mounting DIN rail	35mm
Sealing	IP51 (indoor)
Material	self-extinguishing UL94V-0

► Description

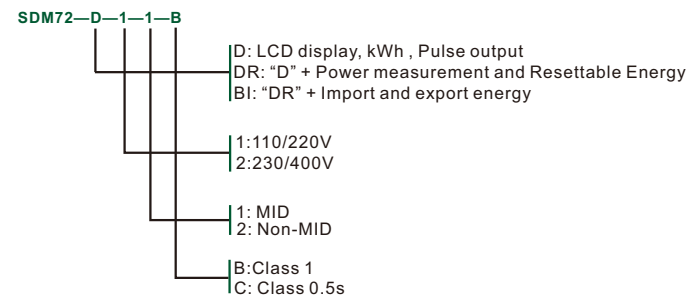

► Wiring diagrams

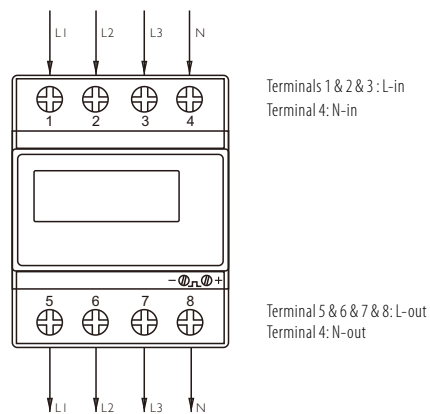

► Dimensions

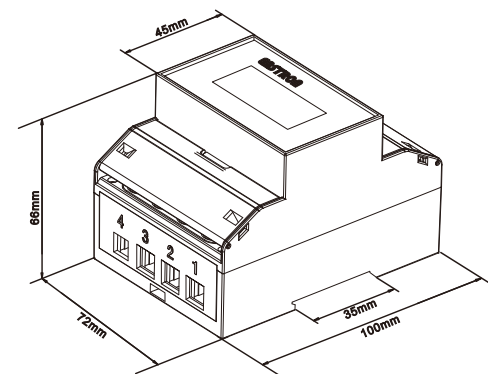

Height 100mm
Width 72mm
Depth 66mm

Specification	
Model	SDM72D-M
Nominal voltage(Un)	3x230/400V ac
Operational voltage	80%~120% of Un
Insulation capabilities	
- AC voltage withstand	4KV for 1 minute
- Impulse voltage withstand	6KV-1.2μS
Basic current (Ib)	10A
Maximum rated current (Imax)	100A
Operational current range	0.4% Ib-Imax
Over current withstand	30 Imax for 0.01s
Operational frequency range	50 or 60Hz
Power consumption per phase	≤ 2W/10VA
Pulse output	1000imp/kWh
Display	LCD
Max reading	999999.9 kWh

Performance criteria	
Operating humidity	≤ 90%
Storage humidity	≤ 95%
Operating temperature	-25°C - +55°C
Storage temperature	-40°C - +70°C
Reference temperature	23°C± 2°C
International standard	IEC 62053-21 / EN50470-1/3
Accuracy class	Class1/Class B
Installation category	CAT III
Mechanical environment	M1
Electromagnetic environment	E2
Degree of pollution	2
Protection against penetration of dust and water	IP51(indoor)
Insulating encased meter of protective class	II
Altitude	up to 2000m
Electrostatic discharges	8kV contact / 15kV air gap
Electromagnetic HF fields	IEC 61000-4-3
Electrical fast transients	4kV
Surge	4kV
Radiated & conducted emissions	EN 55022

Mechanics	
Din rail dimensions	72x100x66 (WxHxD) DIN 43880
Mounting DIN rail	35mm
Sealing	IP51 (indoor)
Material	self-extinguishing UL94V-0

Modbus	
Bus type	RS485(semi-duplex)
Protocol	Modbus RTU
Baud rate	1200/2400/4800/9600bps
Address range	1-247
Max. Bus loading	64pcs
Communication distance	1000M
Parity	EVEN/ODD/NONE
Data bit	8
Stop bit	1

► Description

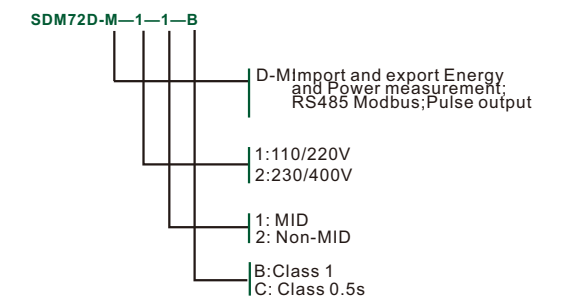

► Wiring diagrams

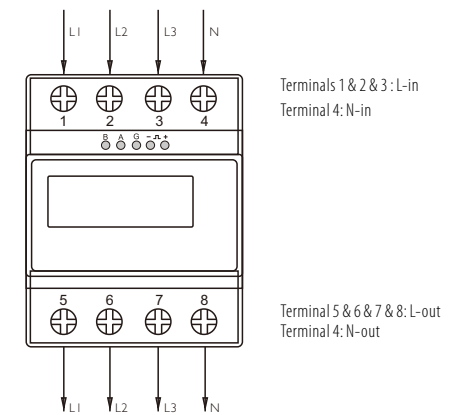

► Dimensions

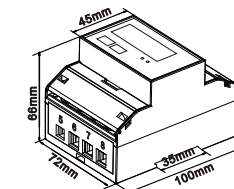

Height 100mm
Width 72mm
Depth 66mm



SDM72CT-D/DR/BI
THREE PHASE FOUR WIRE ENERGY METER

- CT operated
- 4 Module wide
- Measures active energy(kWh)+ power(W)
- Bi-directional measurement
- Resetable energy
- Pulse output

Specification	
Model	SDM72CT-D/DR/BI
Nominal voltage(Un)	3x230/400V ac
Operational voltage	80%~120% of Un
Insulation capabilities	
- AC voltage withstand	4KV for 1 minute
- Impulse voltage withstand	6KV-1.2μS
Basic current (Ib)	5A
Maximum rated current (Imax)	6A
Operational current range	0.4% Ib-Imax
Over current withstand	20 Imax for 0.01s
Operational frequency range	50 or 60Hz
Power consumption per phase	≤ 2W/10VA
Pulse output	1000imp/kWh
Display	LCD
Max reading	999999.9 kWh

Performance criteria	
Operating humidity	≤90%
Storage humidity	≤ 95%
Operating temperature	-25°C - +55°C
Storage temperature	-40°C - +70°C
Reference temperature	23°C± 2°C
International standard	IEC 62053-21 / EN50470-1/3
Accuracy class	Class1/Class B
Installation category	CAT III
Mechanical environment	M1
Electromagnetic environment	E2
Degree of pollution	2
Protection against penetration of dust and water	IP51 (indoor)
Insulating encased meter of protective class	II
Electrostatic discharges	8kV contact / 15kV air gap
Electromagnetic HF fields	IEC 61000-4-3
Electrical fast transients	4kV
Surge	4kV
Radiated & conducted emissions	EN 55022

Mechanics	
Din rail dimensions	72x94.5x65 (WxHxD) DIN 43880
Mounting DIN rail	35mm
Material	self-extinguishing UL94V-0

► Description

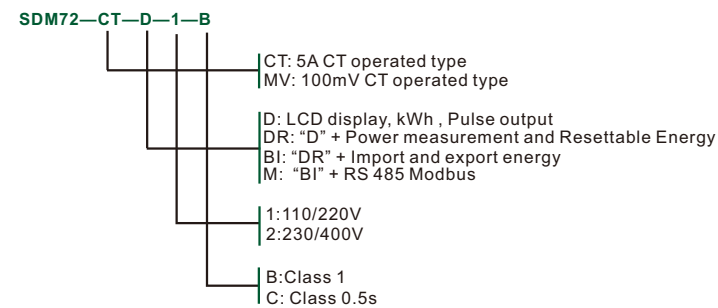

► Wiring diagrams

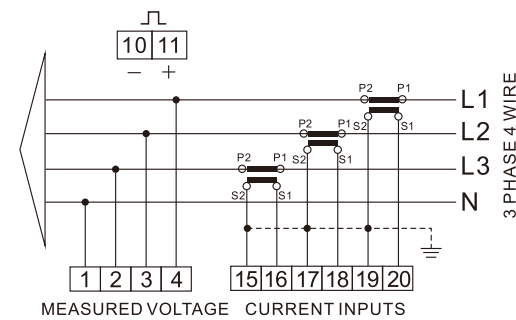

► Dimensions

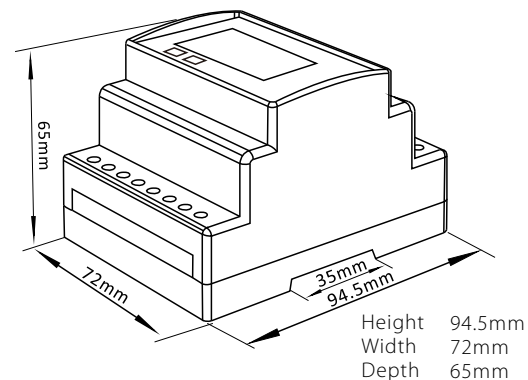

SDM72CT-M
THREE PHASE FOUR WIRE ENERGY METER

- CT operated
- 4 Module wide
- Measures active energy(kWh)+ power(W)
- Bi-directional measurement
- Resetable energy
- RS485+Pulse output

Specification	
Model	SDM72CT-M
Nominal voltage(Un)	3x230/400V ac
Operational voltage	80%~120% of Un
Insulation capabilities	
- AC voltage withstand	4KV for 1 minute
- Impulse voltage withstand	6KV-1.2μS
Basic current (Ib)	5A
Maximum rated current (Imax)	6A
Operational current range	0.4% Ib-Imax
Over current withstand	20 Imax for 0.01s
Operational frequency range	50 or 60Hz
Power consumption per phase	≤ 2W/10VA
Pulse output	1000imp/kWh
Display	LCD
Max reading	999999.9 kWh

Performance criteria	
Operating humidity	≤90%
Storage humidity	≤ 95%
Operating temperature	-25°C - +55°C
Storage temperature	-40°C - +70°C
Reference temperature	23°C± 2°C
International standard	IEC 62053-21
Accuracy class	Class1
Installation category	CAT III
Mechanical environment	M1
Electromagnetic environment	E2
Degree of pollution	2
Protection against penetration of dust and water	IP51 (indoor)
Insulating encased meter of protective class	II
Electrostatic discharges	8kV contact / 15kV air gap
Electromagnetic HF fields	IEC 61000-4-3
Electrical fast transients	4kV
Surge	4kV
Radiated & conducted emissions	EN 55022

Mechanics	
Din rail dimensions	100x125x65 (WxHxD) DIN 43880
Mounting DIN rail	35mm
Material	self-extinguishing UL94V-0

Modbus	
Bus type	RS485(semi-duplex)
Protocol	Modbus RTU
Baud rate	1200/2400/4800/9600bps
Address range	1-247
Max. Bus loading	64pcs
Communication distance	1000M
Parity	EVEN/ODD/NONE
Data bit	8
Stop bit	1

► Description

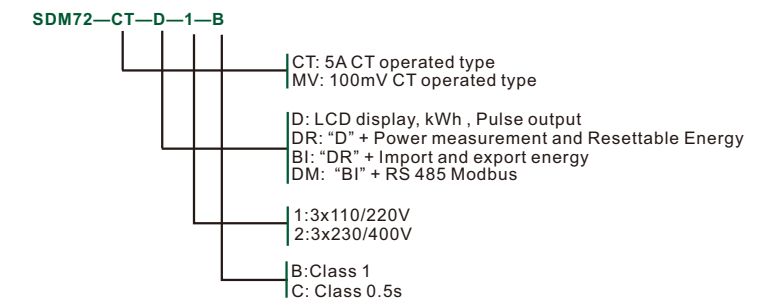

► Wiring diagrams

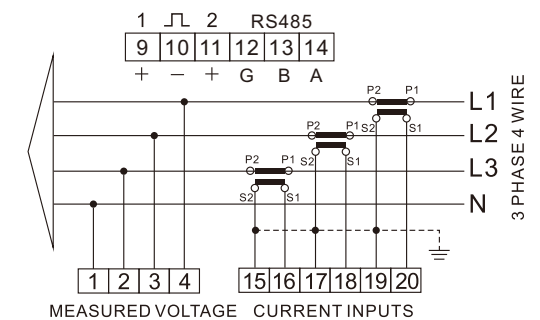

► Dimensions

Height 94.5mm
Width 72mm
Depth 65mm

Smart X96 A Series

SMART ENERGY ANALYZER FOR SINGLE AND THREE PHASE SYSTEMS



- Measures kWh, kVarh, kW, kVar, kVa, P, F, PF, Hz, dmd, V, A, etc.
- Bi-directional measurement Imp & Exp
- Energy information of each phase
- Total harmonic distortion of voltage and current
- 2nd~63rd individual harmonic distortion
- RS485 Modbus RTU & 2 pulse outputs
- Bar graph for power indication
- Three phase self-power supply
- Backlit LCD display for full viewing angles
- Accuracy class 0.2s / 0.5s / 1.0
- Plug-in play solution



Introduction

The Smart X96 digital smart meter from Eastron is an ideal solution for the measurement and display of all important electrical parameters including harmonic distortion of total and individual, up to 63rd. The meter uses a high definition screen with programmable backlight for high visibility in dark area and from all viewing angles. New sector icons shows the percentage of the power load on 3 phases. Modbus RS485 RTU and 2 pulse outputs are equipped as standard.

The Smart X96 and 3-in-1 current transformers provide a simple and fast installation solutions. With pre-cut wiring looms, the meters and CTs can be easily connected. This solution reduces lots of wiring and installation time, and saves wrong wiring troubles.

"Plug-in Play Solution"

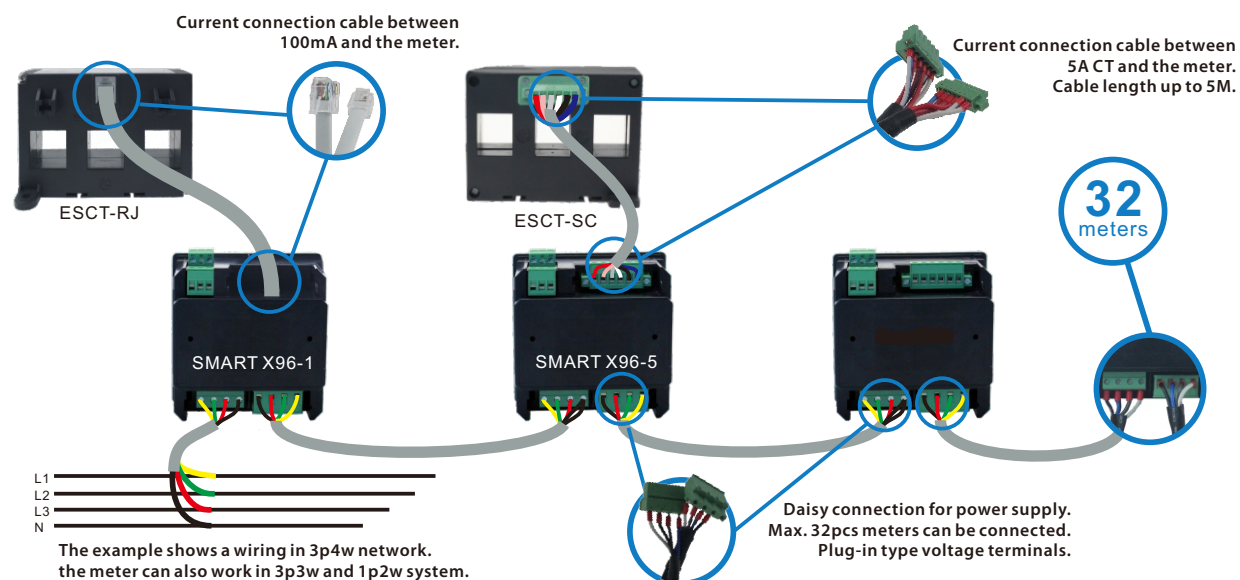

Input	
Nominal input voltage	57.7-276V AC (L-N) 173-480V AC (L-L)
Max. continuous input overload voltage	120% of nominal
Max. short duration input voltage	2 x nominal voltage for 1 second
Nominal input voltage burden	< 0.2VA per phase
Nominal input current	100mA / 5A
Nom. Input current burden	< 0.1 VA
Max. continuous input overload current	120% of nominal
Max. short duration input current	20 x nominal current for 10ms

Power supply	
Operating range	Self powered (from any of the three phases)
Supply burden	≤ 2W / 10VA

Accuracy	
Voltage (V)	0.5% of range maximum
Current (A)	0.5% of range maximum
Frequency (Hz)	0.2% of mid-frequency
Power factor (PF)	1% of unity (0.01)
Active power (W)	1.0% of range maximum
Reactive power (VAR)	1.0% of range maximum
Apparent power (VA)	1.0% of range maximum
Active energy (kWh)	Class 0.5S IEC62053-22 Class 1.0 IEC62053-21
Reactive energy (kVARh)	1.0% of range maximum to IEC 62053-24
THD	2% to 63rd harmonic

Measured Range	
Voltage (V)	15 – 120% of nominal (Min 100V -self powered)
Current (A)	5 – 120% of nominal
Frequency (Hz)	45 – 66 Hz
Power (W, VAR, VA)	5 – 120% of nominal (bi-directional)
Energy	8digit, upto 9999999.9 kWh
Power factor	4 quadrants
THD	Up to 63rd harmonic

Environment	
Operating temperature	-25 °C to +55 °C
Storage temperature	-40 °C to +70 °C
Relative humidity	0 to 95%, non-condensing
Shock	30g in 3 planes
Vibration	10Hz to 50Hz, IEC 60068-2-6, 2g
Dielectric Voltage	4kV between voltage and current to earth
Altitude	3000m
Warm-up	1 minute

Outputs	
Pulse Width	60 / 100 / 200 ms
Pulse rate of S0 1	0.01 / 0.1 / 1 / 10 / 100 / 1000kWh/kVARh
Pulsed output of S0 2 (non-configurable)	3200IMP/kWh
Communications	Modbus RTU (RS485)
Type	2-wire half duplex
Baud rate	2400, 4800, 9600, 19200, 38400bps
Address	1 to 247

Enclosure	
Enclosure Style	DIN 96 panel mount
Dimensions	96x96x70mm
Panel cut-out	92x92mm
Panel thickness	1-3 mm
Protection rating	IP51 (Indoor)
Material	UL 94-V0
Weight	420 g
Cable size	0.05mm-4mm stranded wire
Terminals	Voltage: Shrouded screw-clamp.

Installation

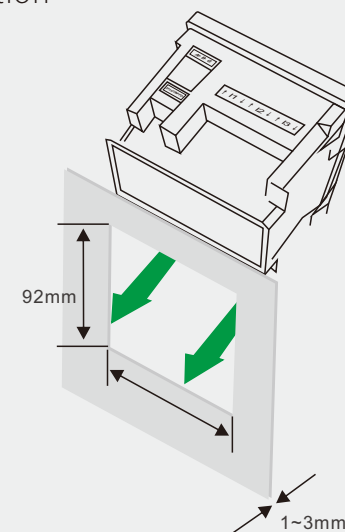

Dimensions

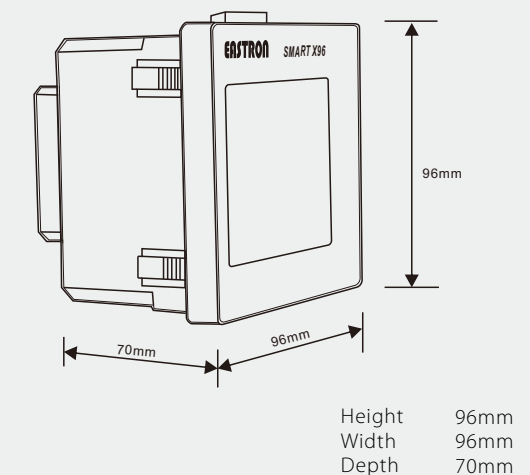

Smart X96 F~J Series

SMART ENERGY ANALYZER FOR SINGLE AND THREE PHASE SYSTEMS



- Multi-parameters measurements
- Up to 63rd THD and IHD
- RS485 Modbus RTU
- Ethernet TCP gateway
- Multi-tariffs
- Digital input/output
- Accuracy class 0.2s
- Bar graph for power indication
- Backlit LCD display for full viewing angles
- Push-in installation and plug-in connection

Introduction

The multifunction energy analyzer SMART X96 F~J series is a top new-generation intelligent panel meter with built-in interfaces provides RS485 Modbus RTU and Ethernet TCP/IP communication. Digital input and outputs are provided for external signal counting and external device control. 30 type's parameters can be set for alarm. This series is widely used not only in the electricity transmission and power distribution system, but also in the power consumption measurement and analysis in LV/MV Intelligent power grid. The Unit can be used as a gateway for Modbus RTU/TCP.

SMART X96 measures and displays the characteristics of 1p2w, 3p4w and 3p3w supplies, including voltage, frequency, current, power and active and reactive energy, imported or exported, Harmonic, Power factor, Max. Demand etc. Energy is measured in terms of kWh, kVAh and kVAh. Maximum demand current can be measured over preset periods of up to 60 minutes. The Smart X96 can be configured to work with a wide range of CTs and PTs, giving the unit a wide range of operation.

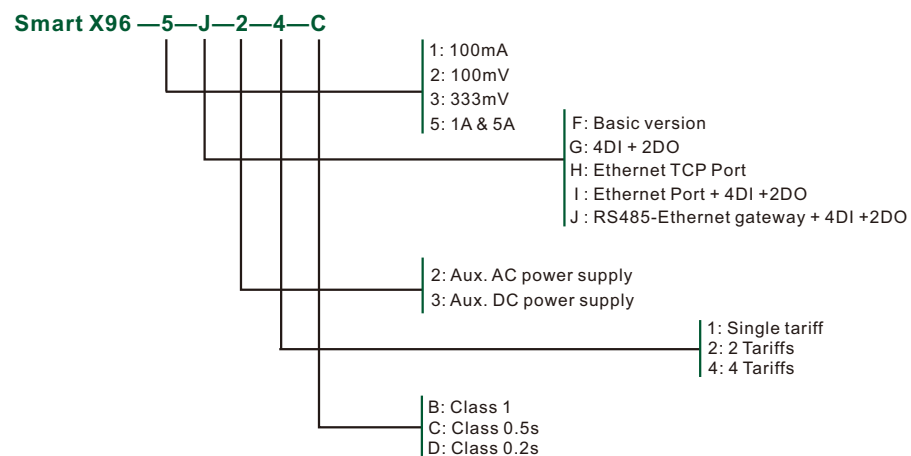

Input	
Nominal input voltage	57.7-276V AC (L-N) 173-480V AC (L-L)
Max. continuous input overload voltage	120% of nominal
Max. short duration input voltage	2 x nominal voltage for 1 second
Nominal input voltage burden	< 0.2VA per phase
Nominal input current	5A
Nom. Input current burden	< 0.1 VA
Max. continuous input overload current	120% of nominal
Max. short duration input current	20 x nominal current for 1 second

Auxiliary Power supply	
Operating range	65-480V AC/80-660V DC
Power consumption	< 2W/10VA

Accuracy	
Voltage (V)	0.5% of range maximum
Current (A)	0.5% of range maximum
Frequency (Hz)	0.2% of mid-frequency
Power factor (PF)	1% of unity (0.01)
Active power (W)	1.0% of range maximum
Reactive power (VAR)	1.0% of range maximum
Apparent power (VA)	1.0% of range maximum
Active energy (kWh)	Class 0.5S IEC62053-22
	Class 1.0 IEC62053-21
Reactive energy (kVAh)	1.0% of range maximum to IEC 62053-24
THD	2% to 63rd harmonic

Measured Range	
Voltage (V)	15 – 120% of nominal (Min 100V -self powered)
Current (A)	5 – 120% of nominal
Frequency (Hz)	45– 66 Hz
Power (W, VAR, VA)	5 – 120% of nominal (bi-directional)
Energy	8digits, up to 9999999.9 kWh
Power factor	4 quadrants
THD	Up to 63rd harmonic

Environment	
Operating temperature	-25 °C to +55 °C
Storage temperature	-40 °C to +70 °C
Relative humidity	0 to 95%, non-condensing
Shock	30g in 3 planes
Vibration	10Hz to 50Hz, IEC 60068-2-6, 2g
Dielectric Voltage	4kV between voltage and current to earth
Altitude	3000m
Warm-up	1 minute

Modbus	
Bus type	RS485(semi-duplex)
Protocol	Modbus RTU/Modbus TCP
Baud rate	2400/4800/9600/19200/38400bps
Address range	1-247
Communication distance	1000M
Parity	EVEN/ODD/NONE
Data bit	8
Stop bit	1
Digital Input	4
Digital Output	2

Enclosure	
Enclosure Style	DIN 96 panel mount
Dimensions	96x96x70 mm
Panel cut-out	92x92mm
Panel thickness	1-3 mm
Protection rating	IP51 (Indoor)
Material	UL 94-V0
Weight	420 g
Cable size	0.05mm-4mm stranded wire
Terminals	Voltage: Shrouded screw-clamp.

Installation

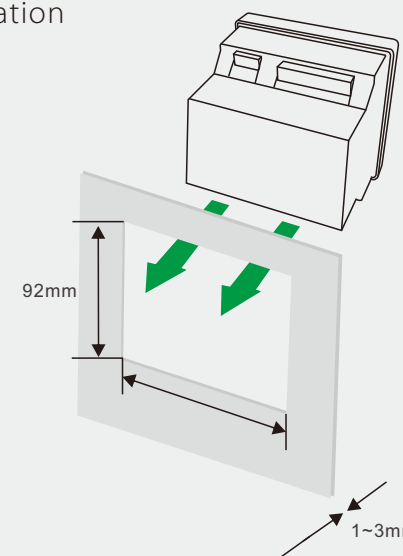

Dimensions

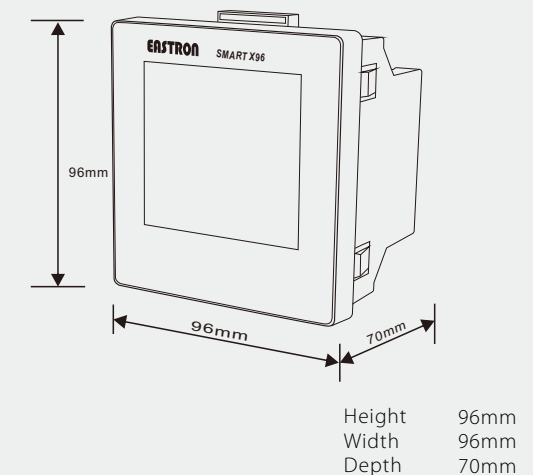

Smart X835 Series

SMART ENERGY ANALYZER FOR SINGLE AND THREE PHASE SYSTEMS



- Multi-parameters measured
- 2nd~63rd individual harmonic distortion
- Support 3p4w, 3p3w, 1p2w system
- CT and PT connected
- Multi tariffs available
- Digital output/ digital input/ analog output / pulse output
- RS485 Modbus communication
- Crest factor & key factor

Introduction

The multifunction energy analyzer SMART X835 series is a new-generation intelligent panel meter, used not only in the electricity transmission and power distribution system, but also in the power consumption measurement and analysis in high voltage intelligent power grid.

The unit measures and displays the characteristics of single phase two wires, three phase three wires and three phase four wires supplies, including voltage, frequency, current, power, active and reactive energy, imported or exported, Harmonic, Power factor, Max. Demand, crest factor and key factor etc. Energy is measured in terms of kWh, kVArh. Maximum demand current can be measured over preset periods of up to 60minutes. In order to measure energy, the unit requires voltage and current inputs in addition to the supply required to power the product. The requisite current input(s) are obtained via current transformers The SMART X835 can be configured to work with a wide range of CTs, giving the unit a wide range of operation. Built-in interfaces provide pulse and RS485 Modbus RTU outputs. Configuration is password protected.

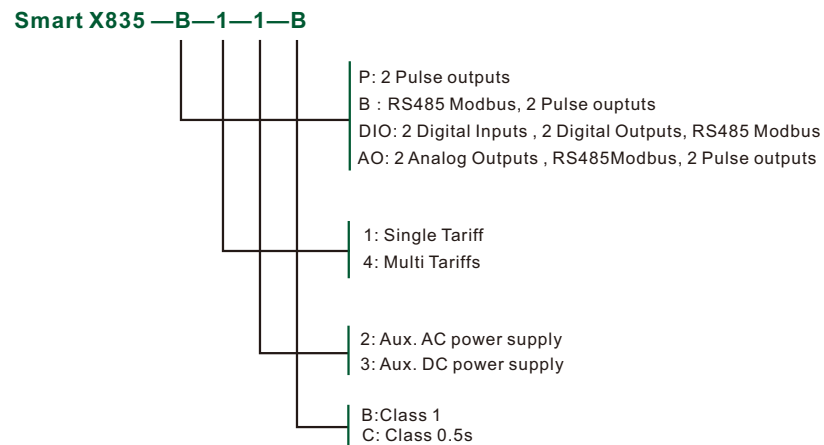

Input	
Nominal input voltage	57.7 – 276V AC L-N (100-480V L-L)
Max. continuous input overload voltage	120% of nominal
Max. short duration input voltage	2 x nominal voltage for 1 second
Nominal input voltage burden	< 0.2VA per phase
Nominal input current	5A
Nom. Input current burden	< 0.1 VA
Max. continuous input overload current	120% of nominal
Max. short duration input current	20 x nominal current for 1 second
Auxiliary	85-276V AC 50/60Hz or 120-380V DC
Supply burden	< 2W / 10 VA

Accuracy	
Voltage (V)	0.5% of range maximum
Current (A)	0.5% of range maximum
Frequency (Hz)	0.2% of mid-frequency
Power factor (PF)	1% of unity (0.01)
Active power (W)	1.0% of range maximum
Reactive power (VAR)	1.0% of range maximum
Apparent power (VA)	1.0% of range maximum
Active energy (kWh)	1.0% of range maximum to IEC 62053-21
Reactive energy (kVArh)	1.0% of range maximum to IEC 62053-24
THD	2% to 63rd harmonic

Measured Range	
Voltage (V)	15 – 120% of nominal (Min 100V – self powered)
Current (A)	5 – 120% of nominal
Frequency (Hz)	45 – 66 Hz
Power (W, VAR, VA)	5 – 120% of nominal (bi-directional)
Energy	8 digits, up to 9999999.9 kWh
Power factor	4 quadrants
THD	Upto 63rd harmonic

Environment	
Operating temperature	-25°C to +55°C
Storage temperature	-40°C to +70°C
Relative humidity	0 to 95%, non-condensing
Shock	30g in 3 planes
Vibration	10Hz to 50Hz, IEC 60068-2-6, 2g
Dielectric Voltage	4kV between voltage and current to earth
Altitude	3000m
Warm-up	1 minute

Outputs	
Pulse Width	60 / 100 / 200 ms
Pulse rate of SO 1	0.01 / 0.1 / 1 / 10 / 100 kWh/kVArh
Pulsed output of SO 2 (non-configurable)	3200IMP/kWh
Communications	Modbus RTU (RS485)
Type	2-wire half duplex
Baud rate	2400, 4800, 9600, 19200, 38400bps
Address	1 to 247

Enclosure	
Enclosure Style	DIN 96 panel mount
Dimensions	96x96x72 mm
Panel cut-out	92x92mm
Panel thickness	1-3 mm
Protection rating	IP51 (Indoor)
Material	UL 94-V0
Weight	340 g
Cable size	0.05mm-4mm stranded wire

Wiring diagram

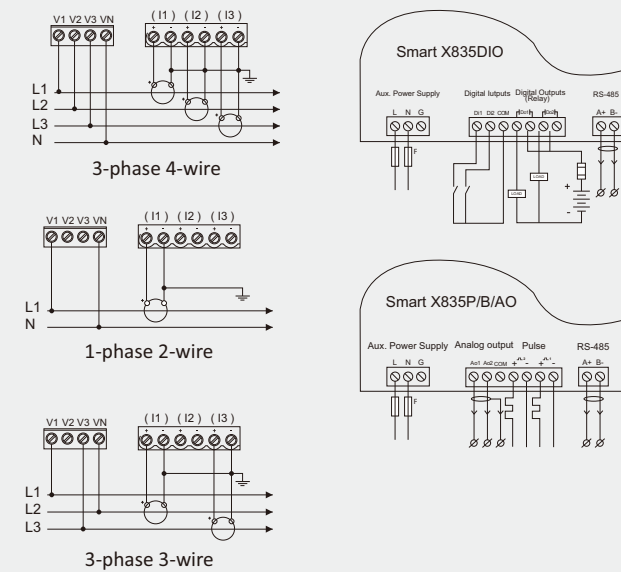

Dimensions

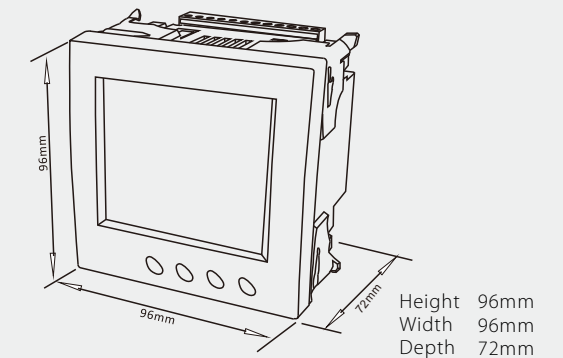



SMART X72

SMART POWER ANALYZER

- THD of voltage and current
- Multi-parameters measured
- RS485 Modbus RTU & 2 pulse output
- Digital input & digital output
- CT&PT programmable
- RoHS & CE

Introduction

The multifunction energy analyzer SMART X72 series is an intelligent panel meter, used not only in the electricity transmission and power distribution system, but also in the power consumption measurement and analysis in high voltage intelligent power grid.

The unit measures and displays the characteristics of single phase two wires, three phase three wires and three phase four wires supplies, including voltage, frequency, current, power, active and reactive energy, imported or exported, Harmonic, Power factor, Max. Demand, etc. Energy is measured in terms of kWh, kVAh. Maximum demand current can be measured over preset periods of up to 60minutes. In order to measure energy, the unit requires voltage and current inputs in addition to the supply required to power the product. The requisite current input(s) are obtained via current transformers The Smart X72 can be configured to work with a wide range of CTs, giving the unit a wide range of operation. Built-in interfaces provide pulses and RS485 Modbus RTU outputs. Configuration is password protected.

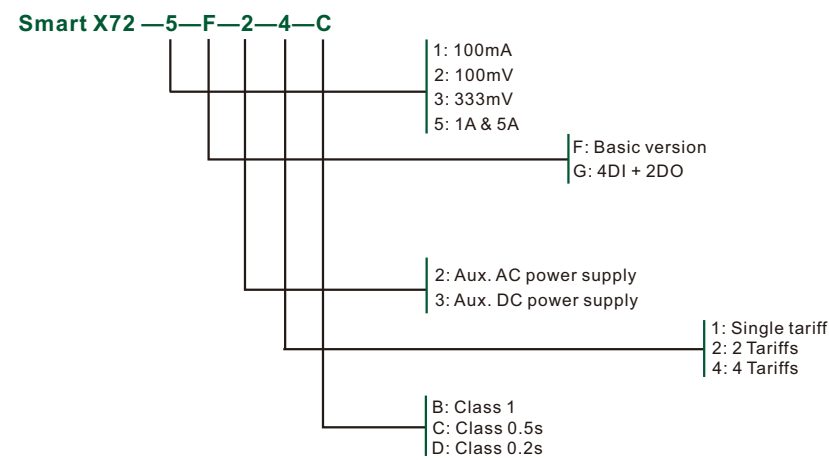

Input	
Nominal input voltage	57.7 – 276V AC L-N (100-480V L-L)
Max. continuous input overload voltage	120% of nominal
Max. short duration input voltage	2 x nominal voltage for 1 second
Nominal input voltage burden	< 0.2VA per phase
Nominal input current	5A
Nom. Input current burden	< 0.1 VA
Max. continuous input overload current	120% of nominal
Max. short duration input current	20 x nominal current for 10ms

Power supply	
Auxiliary	85-276V AC 50/60Hz or 120-380V DC
Supply burden	< 2W /10VA

Accuracy	
Voltage (V)	0.5% of range maximum
Current (A)	0.5% of range maximum
Frequency (Hz)	0.2% of mid-frequency
Power factor (PF)	1% of unity (0.01)
Active power (W)	1.0% of range maximum
Reactive power (VAr)	1.0% of range maximum
Apparent power (VA)	1.0% of range maximum
Active energy (kWh)	1.0% of range maximum to IEC 62053-21
Reactive energy (kVAh)	1.0% of range maximum to IEC 62053-24
THD of current and voltage	2%

Measured Range	
Voltage (V)	15 – 120% of nominal (Min 100V -self powered)
Current (A)	5 – 120% of nominal
Frequency (Hz)	45 – 66 Hz
Power (W, VAr, VA)	5 – 120% of nominal (bi-directional)
Energy	8 digits, up to 9999999.9 kWh
Power factor	4 quadrants
THD	Up to 21st harmonic

Environment	
Operating temperature	-25°C to +55°C
Storage temperature	-40°C to +70°C
Relative humidity	0 to 95%, non-condensing
Shock	30g in 3 planes
Vibration	10Hz to 50Hz, IEC 60068-2-6, 2g
Dielectric Voltage	4kV between voltage and current to earth
Altitude	3000m
Warm-up	1 minute

Outputs	
Communications	Modbus RTU (RS485)
Type	2-wire half duplex
Baud rate	2400,4800, 9600, 19200, 38400bps
Address	1 to 247

Enclosure	
Enclosure Style	DIN 96 panel mount
Dimensions	72x72x74 mm
Panel cut-out	67x67mm
Protection rating	Front IP54, Rear IP30
Material	UL 94-V0
Weight	300 g
Cable size	0.05mm-4mm stranded wire
Terminals	Voltage: Shrouded screw-clamp.

Wiring diagram

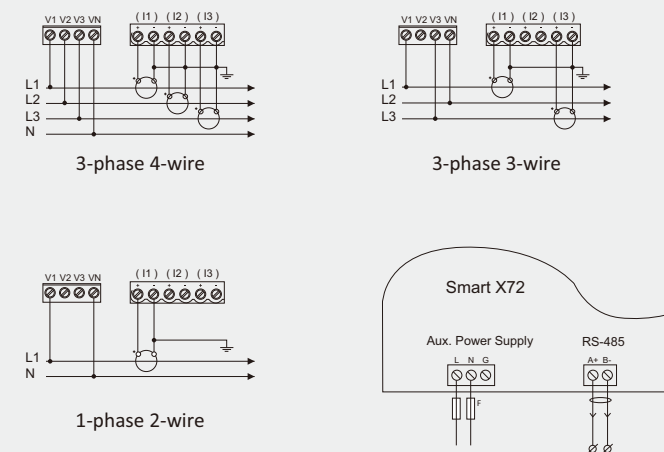

Dimensions

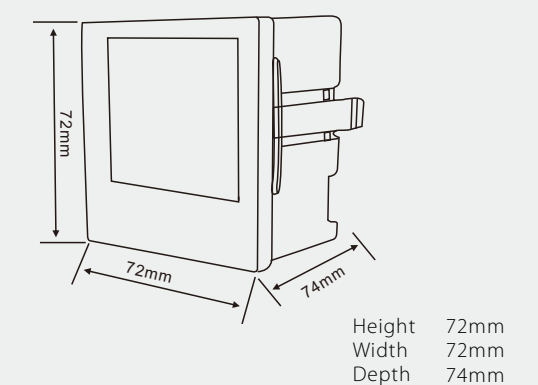



SMARTconnect X835

SMART POWER ANALYZER

- Measures kWh, kVarh, kW, kVar, kVA, P, F, PF,Hz, dmd, V, A, etc.
- Bi-directional Measurement IMP & EXP
- Total Harmonic Distortion of Voltage and Current
- RS485 Modbus RTU & Two Pulse Outputs
- Backlit LCD Display
- Plug-in solution

Introduction

The multifunction energy analyzer Smartconnect X835 series is an economic solution for three phase intelligent panel meter, used not only in the electricity transmission and power distribution system, but also in the power consumption measurement and analysis in high voltage intelligent power grid.

The unit measures and displays the characteristics of single phase two wires, three phase three wires and three phase four wires supplies, including voltage, frequency, current, power, active and reactive energy, imported or exported, THD, Power factor, Max. Demand etc. The meter provides a RS485 communication port for remote reading and monitoring.

Input	
Nominal input voltage	57.7-276V AC (L-N) 173-480V AC(L-L)
Max. continuous input overload voltage	120% of nominal
Max. short duration input voltage	2 x nominal voltage for 1 second
Nominal input voltage burden	< 0.2VA per phase
Nominal input current	333mV / 5A
Nom. Input current burden	< 0.1VA
Max. continuous input overload current	120% of nominal
Max. short duration input current	20 x nominal current for 1 second
Operating range	Self powered (from any of the three phases)
Supply burden	<2W/10VA

Accuracy	
Voltage (V)	0.5% of range maximum
Current (A)	0.5% of range maximum
Frequency (Hz)	0.2% of mid-frequency
Power factor (PF)	1% of unity (0.01)
Active power (W)	1.0% of range maximum
Reactive power (VAr)	1.0% of range maximum
Apparent power (VA)	1.0% of range maximum
Active energy (kWh)	1.0% of range maximum to IEC 62053-21
Reactive energy (kVArh)	1.0% of range maximum to IEC 62053-24
THD	2%

Measured Range	
Voltage (V)	5 – 120% of nominal (Min 100V – self powered)
Current (A)	5 – 120% of nominal
Frequency (Hz)	44 – 66 Hz
Power (W, VAr, VA)	5 – 144% of nominal (bi-directional)
Energy	8 digits, up to 9999999.9 kWh
Power factor	4 quadrants
THD	0 – 40% upto 63rd harmonic

Environment	
Operating temperature	-25°C to +55°C
Storage temperature	-40°C to +70°C
Relative humidity	0 to 95%, non-condensing
Shock	30g in 3 planes
Vibration	10Hz to 50Hz, IEC 60068-2-6, 2g
Dielectric Voltage	4kV between voltage and current to earth
Altitude	3000m
Warm-up	1 minute

Outputs	
Pulse Width	60 / 100 / 200 ms
Pulse rate	0.01 / 0.1 / 1 / 10 / 100 kWh/kVArh
Pulsed output relay (non-configurable)	3200IMP/kWh
Communications	Modbus RTU (RS485)
Type	2-wire half duplex
Baud rate	2400,4800, 9600, 19200, 38400bps
Address	1 to 247

Enclosure	
Enclosure Style	DIN 96 panel mount
Dimensions	96x96x50 mm
Panel cut-out	92x92mm
Protection rating	Front IP54, Rear IP30
Material	UL 94-V0
Weight	300 g
Cable size	0.05mm-4mm stranded wire
Terminals	Voltage: Shrouded screw-clamp.

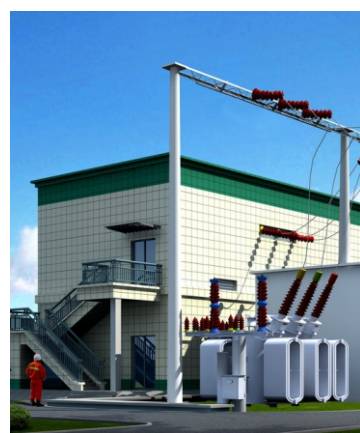

Smartconnect X835 —CT—B

- CT: 5A CT input, Multi Parameters, RS 485 Modbus
- MV: 333mV CT input, Multi Parameters, RS 485 Modbus
- V: 3 phase voltage (L-N, L-L), RS 485 Modbus
- A: 3 phase Current, RS 485 Modbus
- W: 3 phase Current, Voltage and Power, RS 485 Modbus

- B: Class 1
- C: Class 0.5s

Wiring diagram

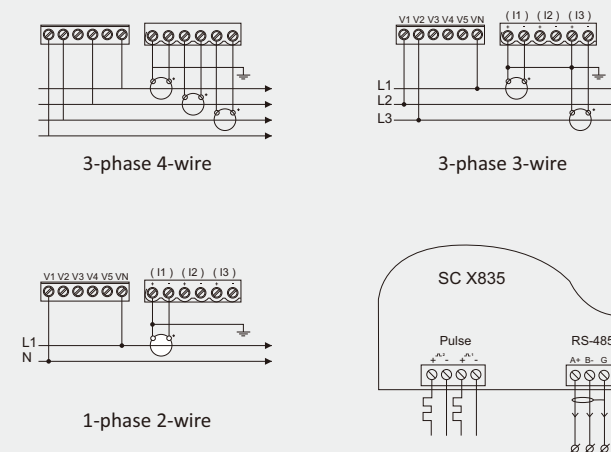

Dimensions

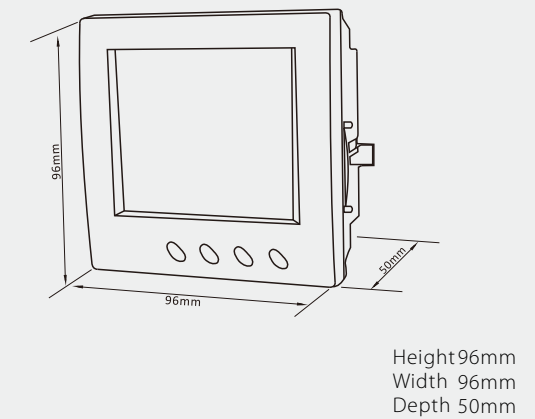



ESP-2000 SERIES

Modbus RTU to Modbus TCP

- Convert Between Modbus TCP and Modbus RTU
- 1 Ethernet port and 1,2,4,8 RS232/422/485 Ports
- Each RS485 port supports up to 256 nodes
- Support DHCP / DNS / HTTP protocols
- Easy Hardware setup

Isolation Character

Power Isolation	3KV
RS485/422 Isolation	2.5KV
HCMTI	2.5KV/us
RS485/422 ESD Protection	15KV

Electrical Character

Voltage Range	18~36V DC, 400~600mW (can be customized 12V input)
Voltage Input	DC Plug or Terminal

Network Interface

Ethernet	10/100 Mbps, RJ45, 2 KV surge protection
Work Mode	TCP Server, TCP Client, UDP/UDP Multicast, TCP Server /Client Coexist

Mechanical Character

Size	L x W x H 9.4cmx6.5cmx2.5cm
------	--------------------------------

Serial Interface

Interface	RS232/485/422 x 1
Baud Rate	1200bps~115200bps
Serial Parameter	Check bit: None, Odd, Even Data bit: 5~9, Stop bit: 1,2; Flow control: RTS/CTS,DTR/DCR, XON/XOFF

Work Environment

Work Temp. Humidity	-45~85°C, 5~95% RH
Storage Temp. Humidity	-45~165°C, 5~95% RH

Introduction

ESP-2000 series is a high performance serial device server and Modbus Gateway product designed by Eastron for lightning resistance, anti-electromagnetic interference and resisting bad environment requirements, is the flagship product on serial device server. The Gateway are designed for easy integration of Modbus TCP and RTU networks. With those models, Modbus serial slave devices can be seamlessly incorporated into an existing Modbus TCP network, and Modbus TCP slaves can be made accessible to serial masters. The ESP-2100, ESP-2200, ESP-2400, ESP-2800 offer features that make network integration easy, customizable, and compatible with any Modbus network.



ESP-2200

Parameter:

Rs232 Interface	Rj45 interface, qty. 2
Rs485 Interface	Terminal, qty. 2
Rs422 Interface	Need customized to open, qty. 2
Input Voltage	DC9~24V, power consumption less than 4W
Size	L x W x H=9.4cmx6.5cmx2.5cm



ESP-2400

Parameter:

Rs232 Interface	Db9, qty. 4
Rs485 Interface	Terminal, qty. 4
Rs422 Interface	4 Line terminal, qty. 4
Input Voltage	DC9~24V, power consumption less than 4W
Size	L x W x H=9.2cmx19.7cmx2.5cm



ESP-2800

Parameter:

Rs232 Interface	Db9, qty. 8
Rs485 Interface	Equip Db9 to terminal pinboard, qty. 8
Rs422 Interface	None
Input Voltage	DC9~24V, power consumption less than 5.4W
Size	L x W x H=27cmx10.5cmx2.6cm

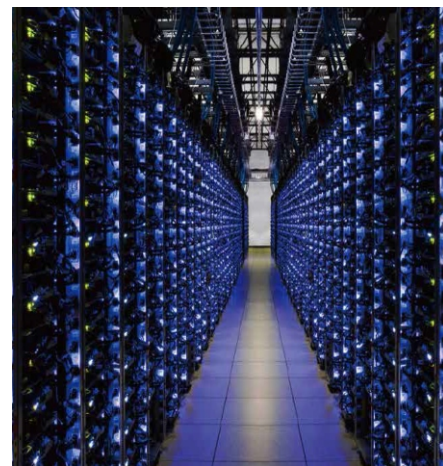

ESP-2—100—1

- 100: 1x RS232/422/485 ports
- 200: 2x RS232/422/485 ports
- 400: 4x RS232/422/485 ports
- 800: 8x RS232/485 ports
- 1: 12V DC aux. power supply
- 2: 24 V DC aux. power supply

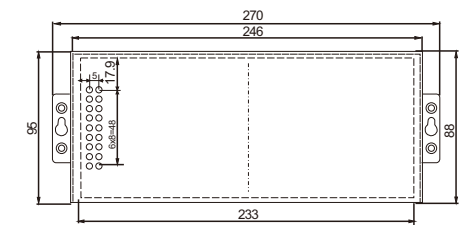
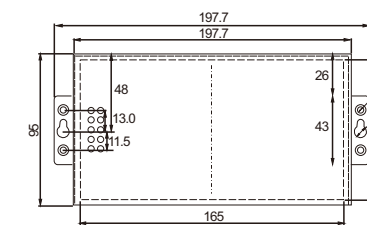
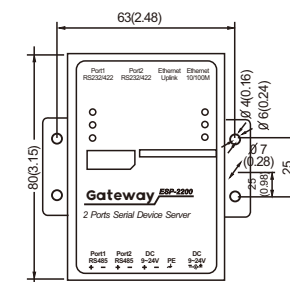



ESP-4000 SERIES

RS232/422/485 to WIFI

- Convert between RS232/422/485 to WIFI
- Ethernet port available
- Each RS485 port supports up to 256 nodes
- Support Modbus TCP to RTU.
- Support IEEE802.11g/b/n
- Easy hardware setup



ESP-5000 SERIES

RS232/485 to GPRS/3G/4G

- Support RS232/485 to GPRS ESP-5100
- Support RS232/485 to 3G/4G ESP-5307
- Support RS232/485 to Ethernet

Introduction

ESP-4142 and ESP-4144 is Wifi serial device server designed by Eastron, supporting RS232/422/485 to Wifi. It supports Ethernet and Wifi simultaneous access. the host serial software can self-adapt serial parameter, without setting device serial baudrate. The ESP-4000 series is a high performance serial device server and Wifi Gateway product designed by for lightning resistance, anti-eletromagnetic interference and resisting bad environment requirements. it provides an easy and wireless integration way of Modbus TCP and RTU networks. With those models, Modbus serial slave devices can be seamlessly incorporated into an existing Modbus TCP network, and Modbus TCP salves can be made accessible to serial masters.

Introduction

ESP-5 series covers 2G/3G/4G mobile network. It converts serial port RS232/RS485 to GPRS (ESP-5100), and to 3G/4G(ESP-5307). ESP-5100 is good option for applications which does not ask high speed communication. ESP-5307 is advanced version with fater transmission speed. ESP-5307 supports TD-LTE/FDD-LTE/WCDMA/TD-SCDMA/GSM. An extra Ethernet port is provided, which can be used at same time when 2G/3G/4G is working. P2P connection is also possible.



WIFI	IEEE802.11b/g
Antenna	Stick antenna, sucker antenna
Interface	RS232/485/422 serial port
Baud Rate	1200bps~115200ps
Network Format	10M/100M self-adapting
Power Interface	In-positive, out-negative, standard outlet; 2 line terminal
Input Voltage	9~48V input, less than 1W
Size	L x W x H=9.4cmx6.5cmx2.5cm
Work Temp. & Humidity	-45~85°C, 5~95% RH

Parameter:

Serial Port Type	RS232/RS485
Baud Rate	1200~115200bps
Frequency range	900MHZ/1800MHZ, GPRS multi-slot class 10/8,GPRS mobile station class B
Transmission Rate	Downlink Max: 85.6kbps; Uplink Max: 42.8kbps; Support PBCCH, Coding schemes CS 1,2,3,4,CSD up to14.4kbps, USSD, PPP-stack
SIM Card Voltage	3V, 1.8V
Antenna Interface	50Ω/SMA (Female)
Interface Type	2 line Terminal or 5.5mm, inside positive outside negative, standard power plug (alternative)
Input Voltage	9~24V DC
Current	No card or standby in 77mA
Size	LxWxH=9.4cmx6.5cmx2.5cm
Work Temp. Humidity	-40~85°C, 5~95% RH

Parameter:

Transmission Rate	1)3G net speed: uplink 5.76Mbps downlink 7.2Mbps. 2)4G net speed: uplink 2Mbps downlink 68Mbps.
SIM Card	Voltage: 3V, 1.8V; Size: Big Card
Antenna Interface	Optional 50Ω/SMA glue stick antenna or sucker antenna
Serial Port Type	RS232/RS485
Serial Parameter	Baud Rate: 1200~115200bps
Power Port	Q2.1 outlet, can be customized to power terminal input
Input Voltage	9~24V DC
Current	<200mA@9V
Size	LxWxH=9.4cmx6.5cmx2.5cm
Work Temp. Humidity	-40~85°C, 5~95% RH



ESP-6000 SERIES

LORA to Ethernet

- Support Lora to Ethernet
- Support Lora to RS485



ESP-7000 SERIES

Rs485 to LOR/Wifi/Ethernet

- Support RS485 to Lora ESP-7100
- Support RS485 to Wifi ESP-7110
- Support RS485 to Ethernet ESP-7120

Introduction

ESP-6 is a high-performance LoRa gateway that implements RS485 and LoRa, TCP / IP and LoRa-related translation functions. As a gateway in LoRa network, ESP-6 adopts LoRa ad hoc network communication mode, and LoRa meter or LoRa converter can form a perfect LoRa remote meter reading system. LoRa network using MESH wireless Ad Hoc network, while supporting star, cluster network, the depth of the leading network routing, automatically select the best route, up to 4 relay hopping; with routing auto-repair feature to achieve seamless new Add or delete devices without manual intervention in routing operations.

Introduction

ESP-7 Series is a high-performance converter, to achieve RS485 and LoRa / WIFI / Ethernet conversion function. RS485 port can be connected to the conventional RS485 communication meter, through the built-in processor, to achieve the conversion of the two communications. ESP-7100 converts RS485 to LoRa; ESP-7110 converts RS485 to Wifi; ESP7120 converts RS485 to Ethernet. With ESP series Gateway, they can be used to cooperate with LoRa Gateway (ESP-6 series) to form a complete wire / wireless meter reading system.

Input channel:

Communication mode	LoRaMESH or LoRaWan
Communication frequency	433Mhz, 470Mhz, 868Mhz, 915Mhz
Communication speed	2.93~0.5 kbps A (Configurable)
Maximum transmit power	20dBm
Receiver sensitivity	-112dBm/9.6kbps @GFSK
Maximum communication distance Point to point	1.5km (urban road); 2.5km (Open area)
Networking mode	MESHwireless ad hoc network, up to 4 relay hopping

Output channel :

Output port 1	Ethernet
Interface parameters	RJ45,10/100Mbps
Operating mode	TCP server
Output port 2	RS485 Modbus RTU
Baud rate	1200 ~ 38400 bps
Parity	None/Odd/Even
Stop bit	1/2 bit
Data bits	8 bit

Temperature and humidity parameter:

Operating temperature	-25 to 55°C
Storage temperature	-40°C to +70°C
Humidity range	0 to 95%, No condensation

Power supply parameters:

Supply voltage	9~24VDC, maximum power consumption<2.5W
Maximum input voltage	28VDC

Input channel:

Input port	Rs485 Modbus RTU
Baud rate	1200 ~ 38400 bps
Parity bit	None/Odd/Even
Stop bit	1/2 bit
Data bits	8 bit
Max. Bus Load	32pcs Submeters

Temperature and humidity parameter:

Operating temperature	-25 to 55°C
Storage temperature	-40°C to +70°C
Humidity range	0 to 95%, No condensation

Power supply parameters:

Supply voltage	9~24VDC, maximum power consumption<1.5W
Maximum input voltage	28VDC

ESP-7100 Output :

Communication mode	LoRaMESH or LoRaWan
Communication frequency	433Mhz, 470Mhz, 868Mhz, 915Mhz
Communication speed	2.93~0.5 kbps (Configurable)
Maximum transmit power	20dBm
Receiver sensitivity	-112dBm/9.6kbps @GFSK
Maximum communication distance Point to point	1km (urban road); 2km (Open area)
Networking mode	MESHwireless ad hoc network, up to 4 relay hopping

ESP-7110 Output :

WIFI	IEEE802.11b/g
Antenna	Stick antenna, sucker antenna

ESP-7120 Output :

Ethernet	10/100 Mbps, RJ45,2 KV surge protection
Work Mode	TCP Server, TCP Client,UDP/UDP Multicast, TCP Server/Client Coexist



ESCT-RJ Series 3-IN-1 CURRENT TRANSFORMER

- Cost effective three-phase moulded case
- Ratio's ranging from 60A~630A
- RJ12 socket for quick connection and to eliminate wiring error
- Busbar, DIN-rail and metal feet are supplied as standard

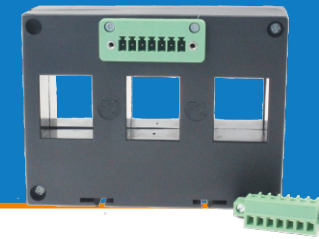

ESCT-SC Series 3-IN-1 CURRENT TRANSFORMER

- Cost effective three-phase moulded case
- Ratio's ranging from 60/5 to 630/5
- Plug-in quite connection, 80% labor saving
- Lockable terminal for safety
- Both available for Busbar or DIN Rail mounted

Specification	
Frequency	50Hz-60Hz
Rated current	60A to 630A loads
Rated output	100mA / 333mV (AC)
Secondary terminals	RJ12
Aperture holes centers	35,45mm
Accuracy	Class 0.5 or 1 from 20% to 120% of rated current
Phase angle	Less than 2 degrees at 50% of rated current
Insulation voltage	600Vac
Maximum primary voltage	5000Vac (Insulated Conductor)
Dielectric strength	2.5KV/1mA/1min
Operating temperature	-15°C to 60°C
Operating humidity	<85%
Case material	PC / UL 94-V0
Bobbin	PBT
Internal structure	Epoxy
Compliant with	IEC/EN60044/1

Model	Rated Amp	Output	Burden (VA)	
			class:0.5	Class:1.0
ESCT-RJ335	60A	100mV/100mA	0.25	0.25
ESCT-RJ335	125A	100mV/100mA	0.25	0.5
ESCT-RJ335	150A	100mV/100mA	0.25	0.5
ESCT-RJ335	200A	100mV/100mA	0.25	0.5
ESCT-RJ335	250A	100mV/100mA	0.25	0.5
ESCT-RJ345	250A	100mV/100mA	0.25	0.5
ESCT-RJ345	300A	100mV/100mA	0.25	0.5
ESCT-RJ345	400A	100mV/100mA	0.25	0.5
ESCT-RJ345	500A	100mV/100mA	0.25	0.5
ESCT-RJ345	600A	100mV/100mA	0.25	0.5
ESCT-RJ345	630A	100mV/100mA	0.25	0.5

► Dimensions

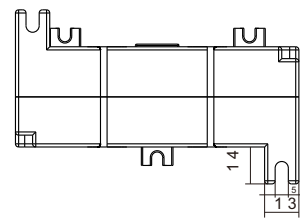
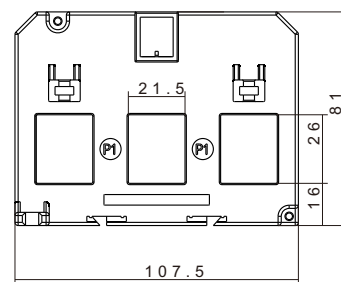

ESCT-RJ335

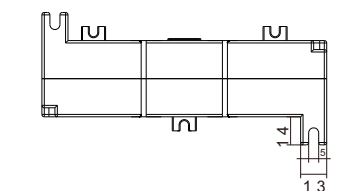
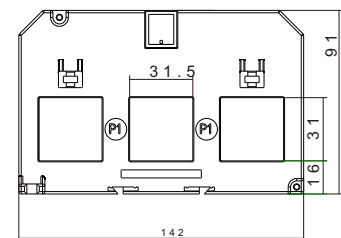

ESCT-RJ345

Specification	
System voltage	720V maximum
Test voltage	3kV for 1 minute
System frequency	50Hz or 60Hz
Primary ratings	60A to 630A
Short circuit thermal current	60 x rated primary current
Overload withstand	1.2 x rated current continuously
Rated dynamic current	2.55 x Ith
Secondary terminals	M4 screw terminals
Enclosure	Flame retardant grad classified UL 94V-0
Aperture holes centers	25,35,45mm
Mounting hardware	Plug-in metal feet for wall or base Mounting
	Bus-bar and DIN-rail
Compliant with	IEC/EN60044-1

Model	Ratio (A)	Burden (VA)	
		class:0.5	Class:1.0
ESCT-SC325	60/1 or 0.5	-	1
ESCT-SC325	100/1 or 0.5	-	1.5
ESCT-SC325	125/1 or 0.5	1.5	1.5
ESCT-SC325	150/1 or 0.5	1.5	1.5
ESCT-SC325	300/1 or 0.5	1.5	1.5
ESCT-SC335	100/1 or 0.5	-	1.5
ESCT-SC335	125/1 or 0.5	-	1.5
ESCT-SC335	150/1 or 0.5	-	1.5
ESCT-SC335	160/1 or 0.5	1.5	1.5
ESCT-SC335	200/1 or 0.5	1.5	1.5
ESCT-SC335	250/1 or 0.5	1.5	1.5
ESCT-C345	250/1 or 0.5	1.5	1.5
ESCT-C345	300/1 or 0.5	2.5	2.5
ESCT-C345	400/1 or 0.5	2.5	2.5
ESCT-C345	500/1 or 0.5	2.5	2.5
ESCT-C345	600/1 or 0.5	2.5	2.5
ESCT-C345	630/1 or 0.5	2.5	2.5

► Dimensions

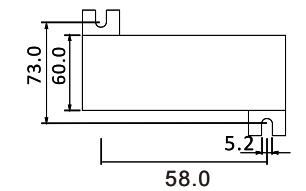
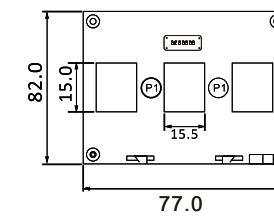

ESCT-SC325

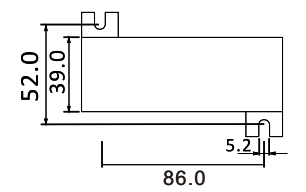
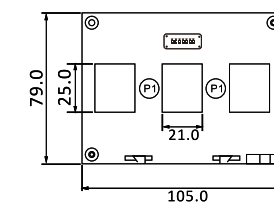

ESCT-SC335

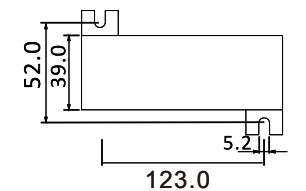
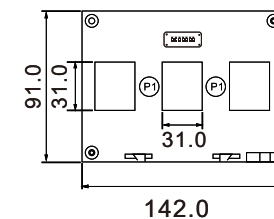

ESCT-SC345

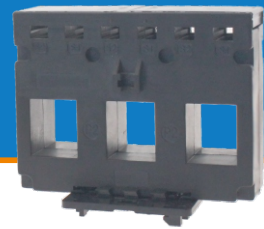

ESCT-C Series 3-IN-1 CURRENT TRANSFORMER

- Cost effective three-phase moulded case
- Ratio's ranging from 60/5 to 630/5
- Integrated wire sealable terminal cover
- Busbar, DIN-rail and metal feet mounting hardware supplied
- Combined M4 posi /slot screw

Specification	
Rated current	60A to 630A loads
Rated output	5A (AC)
Accuracy	Class 0.5 or 1 from 20% to 120% of rated current
Phase angle	Less than 2 degrees at 50% of rated current
Insulation voltage	600Vac
Maximum primary voltage	5000Vac (Insulated Conductor)
Dielectric strength	2.5KV /1mA /1min
Operating temperature	-15°C to 60°C
Operating humidity	<85%
Case material	PC / UL 94-V0
Bobbin	PBT
Internal structure	Epoxy

Model	Ratio (A)	Burden (VA)	
		class:0.5	Class:1.0
ESCT-C325	60/5	-	1
ESCT-C325	100/5	-	1.5
ESCT-C325	125/5	1.5	1.5
ESCT-C325	150/5	1.5	1.5
ESCT-C325	200/5	1.5	1.5
ESCT-C335	100/5	-	1.5
ESCT-C335	125/5	-	2.5
ESCT-C335	150/5	-	3.75
ESCT-C335	160/5	1.5	1.5
ESCT-C335	200/5	1.5	1.5
ESCT-C335	250/5	1.5	1.5
ESCT-C345	250/5	1.5	1.5
ESCT-C345	300/5	2.5	2.5
ESCT-C345	400/5	2.5	2.5
ESCT-C345	500/5	2.5	2.5
ESCT-C345	600/5	2.5	2.5
ESCT-C345	630/5	2.5	2.5

► Dimensions

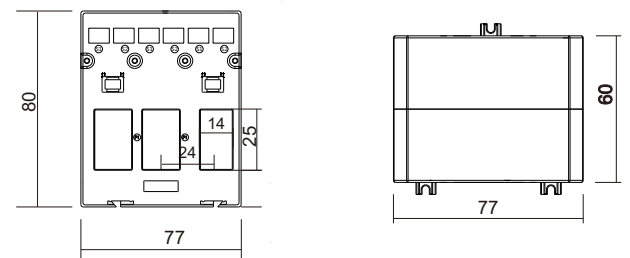

ESCT-C325

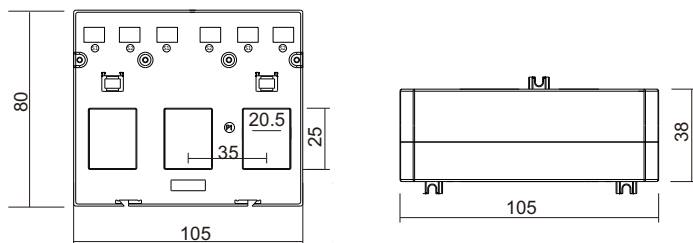

ESCT-C335

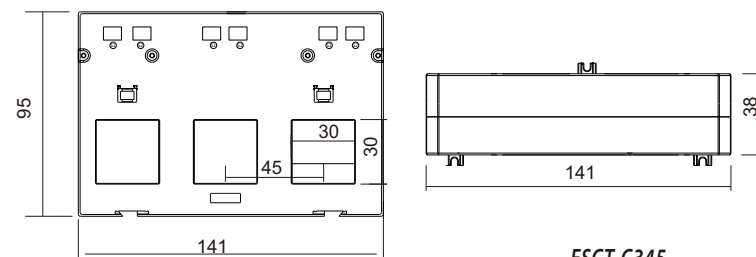

ESCT-C345



ESCT-B Series SPLIT CORE CURRENT TRANSFORMER

- Split Core
- Primary input 100A~6000A
- Secondary output 5A / 1A
- Two building fixing methods: Base; Busbar mounting
- Wide inner window, allowing clamping of big cables or bus-bars
- Standard: IEC60044-1, EN60044-1, VDE0414-44-1, GB1208-2006

Specification	
Frequency	50Hz-60Hz
Rated current	100A to 6000A loads
Rated output	5A / 1A (AC)
Accuracy	Class 0.5 or 1 from 20% to 120% of rated current
Phase angle	less than 2 degrees at 50% of rated current
Insulation voltage	600Vac
Maximum primary voltage	5000Vac (Insulated Conductor)
Dielectric strength	2.5KV /1mA /1min
Operating temperature	-15°C to 60°C
Operating humidity	<85%
Case material	PC / UL 94-V0
Bobbin	PBT
Internal structure	Epoxy

Model	Ratio (A)	Burden (VA)	
		class:0.5	Class:1.0
ESCT-B23	100/5	1.5	2.5
ESCT-B23	150/5	1.5	2.5
ESCT-B23	200/5	2.5	3.75
ESCT-B23	250/5	2.5	5
ESCT-B23	300/5	5	5
ESCT-B23	400/5	5	5
ESCT-B58	250/5	1.5	2.5
ESCT-B58	300/5	2.5	5
ESCT-B58	400/5	3.75	5
ESCT-B58	500/5	5	7.5
ESCT-B58	600/5	5	7.5
ESCT-B58	750/5	5	10
ESCT-B58	800/5	5	10
ESCT-B58	1000/5	7.5	10
ESCT-B812	500/5	2.5	5
ESCT-B812	600/5	2.5	5
ESCT-B812	750/5	5	10
ESCT-B812	800/5	5	10
ESCT-B812	1000/5	7.5	10
ESCT-B812	1200/5	7.5	10
ESCT-B812	1250/5	7.5	10
ESCT-B812	1500/5	7.5	10
ESCT-B816	1000/5	10	15
ESCT-B816	1500/5	10	15
ESCT-B816	2000/5	15	20
ESCT-B816	2500/5	20	25
ESCT-B816	3000/5	20	30
ESCT-B816	4000/5	20	30
ESCT-B816	5000/5	20	30
ESCT-B816	6000/5	20	30

► Dimensions

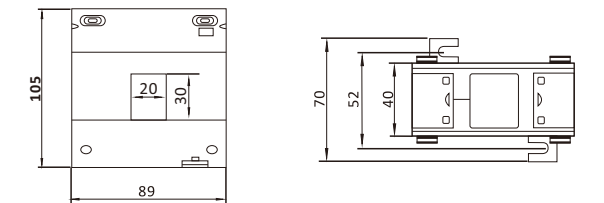

ESCT-B23

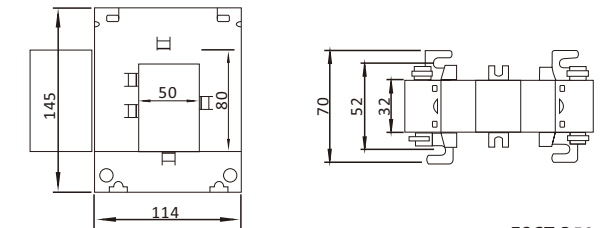

ESCT-B58

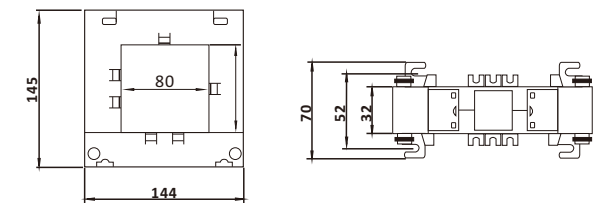

ESCT-B88

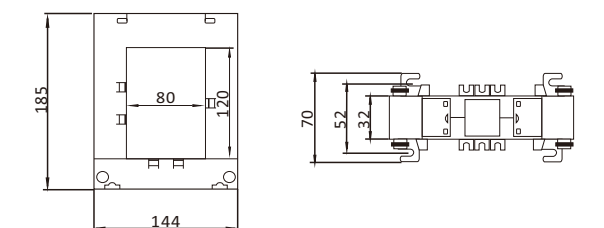

ESCT-B812

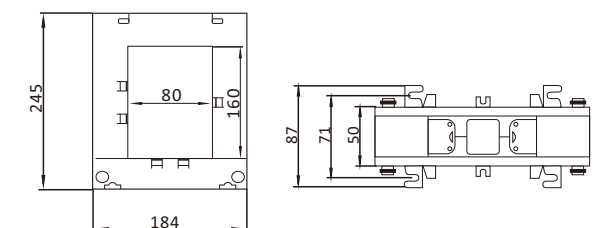

ESCT-B816



ESCT-T Series SPLIT CORE CURRENT TRANSFORMER

- Split Core, easy installation
- Primary input 100A~600A
- Secondary output 5A / 1A
- Safe operation
- Standard: IEC60044-1, EN60044-1, VDE0414-44-1, GB1208-2006



ESCT-TU Series MINI SPLIT CORE CURRENT TRANSFORMER

- Split Core, easy installation
- Primary input 5A~600A
- Secondary output 333mV / 100mV / 100mA
- Safe operation
- Standard: IEC60044-1, EN60044-1, VDE0414-44-1, GB1208-2006

Specification	
Frequency	50-60Hz
Rated current	100A to 600A loads
Rated output	1A / 5A (AC)
Accuracy	Class 0.5 or 1 from 20% to 120% of rated current
Phase angle	Less than 2 degrees at 50% of rated current
Insulation voltage	600Vac
Maximum primary voltage	5000Vac (Insulated Conductor)
Dielectric strength	2.5KV/1mA/1min
Operating temperature	-15°C to 60°C.
Operating humidity	<85%
Case material	PC / UL94-V0
Bobbin	PBT
Core	Permalloy
Internal structure	Epoxy

Model	Ratio (A)	Burden (VA)	
		class 0.5	Class 1.0
ESCT-T24-1	100/1	-	1.5
ESCT-T24-1	150/1	-	1.5
ESCT-T24-1	200/1	1.5	2.5
ESCT-T24-1	250/1	1.5	2.5
ESCT-T24-1	300/1	1.5	2.5
ESCT-T36-1	100/1	-	1.5
ESCT-T36-1	150/1	-	1.5
ESCT-T36-1	200/1	1.5	2.5
ESCT-T36-1	300/1	1.5	2.5
ESCT-T36-1	400/1	1.5	2.5
ESCT-T36-1	500/1	2.5	3.75
ESCT-T36-1	600/1	2.5	5
ESCT-T24-5	100/5	-	1.5
ESCT-T24-5	150/5	-	1.5
ESCT-T24-5	200/5	1.5	2.5
ESCT-T24-5	250/5	1.5	2.5
ESCT-T24-5	300/5	1.5	2.5
ESCT-T36-5	100/5	-	1.5
ESCT-T36-5	150/5	-	1.5
ESCT-T36-5	200/5	1.5	2.5
ESCT-T36-5	300/5	1.5	2.5
ESCT-T36-5	400/5	1.5	2.5
ESCT-T36-5	500/5	2.5	3.75
ESCT-T36-5	600/5	2.5	5

► Dimensions

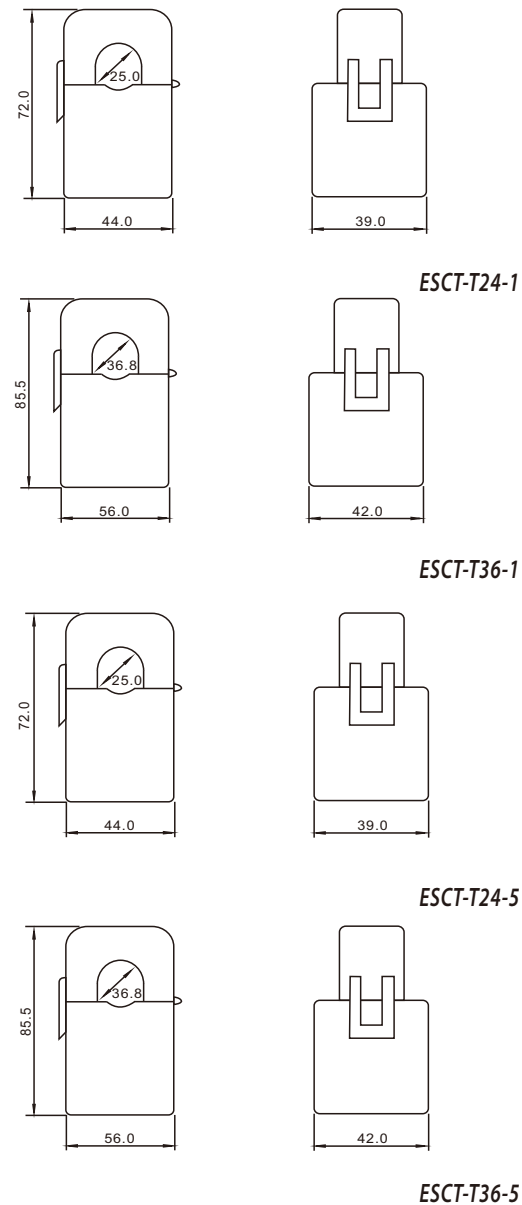

Specification	
Frequency	50-60Hz
Rated current	5A to 600A loads
Rated output	100mA/333mV/100mV (AC)
Accuracy	Class 0.5 or 1 from 20% to 120% of rated current
Phase angle	less than 2 degrees at 50% of rated current
Insulation voltage	600Vac
Maximum primary voltage	5000Vac (Insulated Conductor)
Dielectric strength	2.5KV/1mA/1min
Operating temperature	-15°C to 60°C.
Operating humidity	<85%
Case material	PC / UL94-V0
Bobbin	PBT
Core	Permalloy
Internal structure	Epoxy
Leads	UL 1015, Twisted Pair, 22AWG

► Dimension

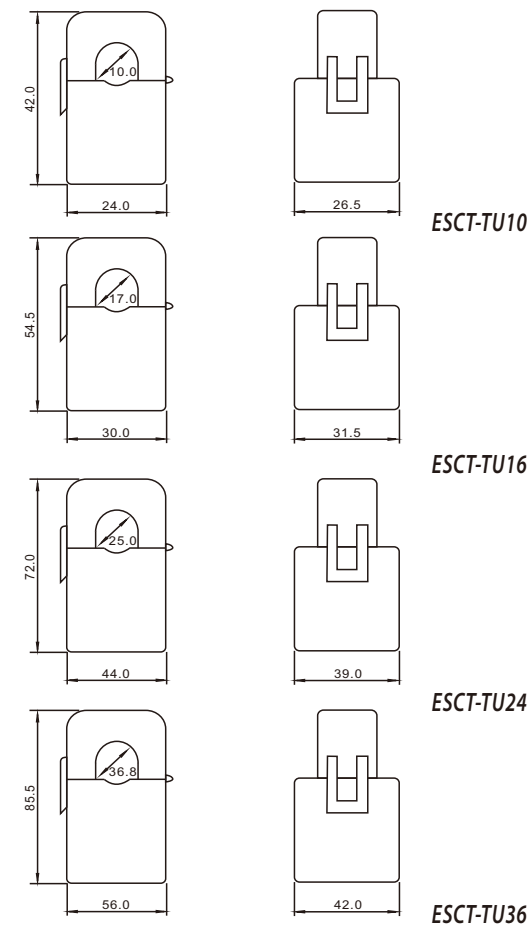

Model	Rated Amps	Output(mV)	Accuracy
ESCT-TU10	5	333	0.5 or 1
ESCT-TU10	10	333	0.5 or 1
ESCT-TU10	20	333	0.5 or 1
ESCT-TU10	50	333	0.5 or 1
ESCT-TU10	75	333	0.5 or 1
ESCT-TU10	5	100	0.5 or 1
ESCT-TU10	10	100	0.5 or 1
ESCT-TU10	20	100	0.5 or 1
ESCT-TU10	50	100	0.5 or 1
ESCT-TU10	75	100	0.5 or 1
ESCT-TU16	5	333	0.5 or 1
ESCT-TU16	10	333	0.5 or 1
ESCT-TU16	50	333	0.5 or 1
ESCT-TU16	100	333	0.5 or 1
ESCT-TU16	150	333	0.5 or 1
ESCT-TU16	5	100	0.5 or 1
ESCT-TU16	10	100	0.5 or 1
ESCT-TU16	50	100	0.5 or 1
ESCT-TU16	100	100	0.5 or 1
ESCT-TU16	150	100	0.5 or 1
ESCT-TU24	10	333	0.5 or 1
ESCT-TU24	50	333	0.5 or 1
ESCT-TU24	100	333	0.5 or 1
ESCT-TU24	250	333	0.5 or 1
ESCT-TU24	300	333	0.5 or 1
ESCT-TU24	10	100	0.5 or 1
ESCT-TU24	50	100	0.5 or 1
ESCT-TU24	100	100	0.5 or 1
ESCT-TU24	250	100	0.5 or 1
ESCT-TU24	300	100	0.5 or 1
ESCT-TU36	20	333	0.5 or 1
ESCT-TU36	100	333	0.5 or 1
ESCT-TU36	250	333	0.5 or 1
ESCT-TU36	400	333	0.5 or 1
ESCT-TU36	600	333	0.5 or 1
ESCT-TU36	20	100	0.5 or 1
ESCT-TU36	100	100	0.5 or 1
ESCT-TU36	250	100	0.5 or 1
ESCT-TU36	400	100	0.5 or 1
ESCT-TU36	600	100	0.5 or 1



ESCT-U Series SPLIT CORE CURRENT TRANSFORMER

- Split Core, easy installation
- Primary input 5A~3000A
- Secondary output 333mV
- Wide inner window, allowing clamping of big cables
- Standard: IEC60044-1, EN60044-1, VDE0414-44-1, GB1208-2006

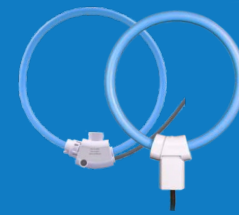

ESCT-RC FLEXIBLE ROGOWSKI COIL CURRENT SENSOR

- Flexible and light weights
- Easy & quick installation in tight spaces
- No danger from open-circuited secondary
- No core saturation or damage if overloaded
- excellent linearity
- Multi- size are available
- Single phase and three phase are available

Specification	
Frequency	50-60Hz
Rated current	5A to 3000A loads
Rated output	333mV (AC)
Accuracy	± 1% from 20% to 120% of rated current
Phase angle	less than 2 degrees at 50% of rated current
Insulation voltage	600Vac
Maximum primary voltage	5000Vac (Insulated Conductor)
Dielectric strength	2.5KV/1mA/1min
Operating temperature	-15°C to 60°C.
Operating humidity	<85%
Case material	PC / UL94-V0
Bobbin	PBT
Core	Permalloy
Internal structure	Epoxy
Leads	UL 1015, Twisted Pair, 22AWG

Model	Rated Amps	Output(mV)	Accuracy
ESCT-U75	5	333	0.5or1
ESCT-U75	10	333	0.5or1
ESCT-U75	50	333	0.5or1
ESCT-U75	75	333	0.5or1
ESCT-U75	100	333	0.5or1
ESCT-U75	125	333	0.5or1
ESCT-U75	150	333	0.5or1
ESCT-U75	200	333	0.5or1
ESCT-U125	50	333	0.5or1
ESCT-U125	100	333	0.5or1
ESCT-U125	200	333	0.5or1
ESCT-U125	250	333	0.5or1
ESCT-U125	400	333	0.5or1
ESCT-U125	600	333	0.5or1
ESCT-U200	100	333	0.5or1
ESCT-U200	125	333	0.5or1
ESCT-U200	250	333	0.5or1
ESCT-U200	400	333	0.5or1
ESCT-U200	630	333	0.5or1
ESCT-U200	800	333	0.5or1
ESCT-U200	1000	333	0.5or1
ESCT-U200	2000	333	0.5or1
ESCT-U300	400	333	0.5or1
ESCT-U300	800	333	0.5or1
ESCT-U300	1000	333	0.5or1
ESCT-U300	1500	333	0.5or1
ESCT-U300	2500	333	0.5or1
ESCT-U300	3000	333	0.5or1

► Dimension

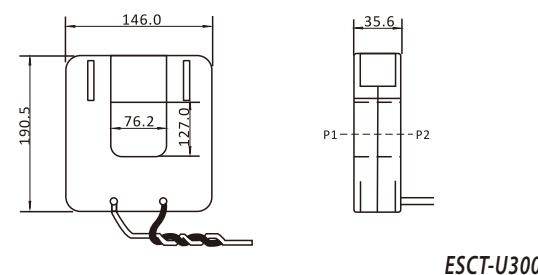
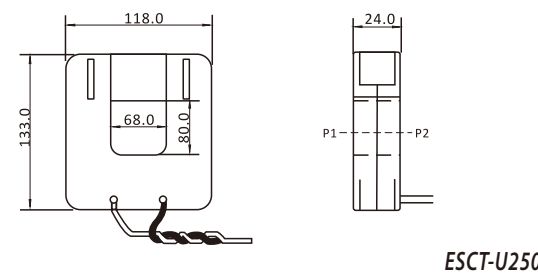
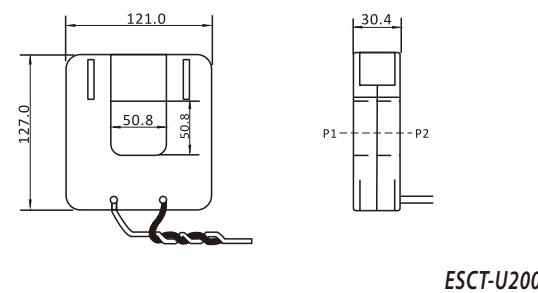
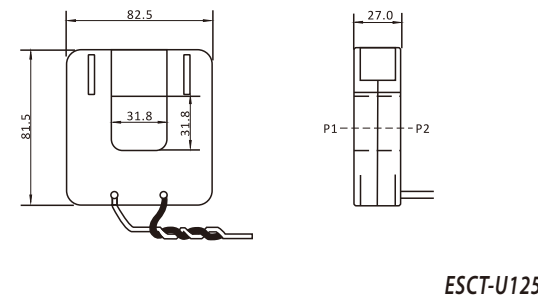
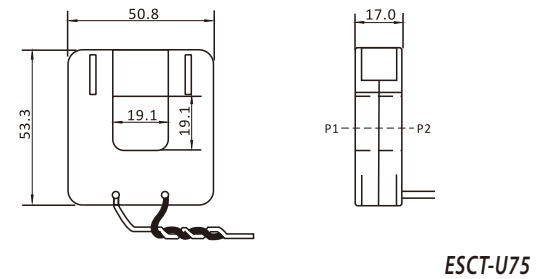

Specification	
Current Range	10A to 100kA
Rated output	0.333Vac at rated current with Integrator, 100mV/per 1000A @ 50Hz without integrator
Accuracy	± 1% from 5% to 120% of rated current with integrator(45-65Hz)
Phase Angle	≤±1°5% to 120% from 5% to 120% of rated current
Linear	0.5%
Frequency	1Hz-1MHz ,50/60 Hz nominal
Work Voltage	600V
Power supply	7-30VDC (9 Vdc, 12 Vdc recommended)
Coil Diameter	10.5mm, 12mm or as customer order
Window size	10mm, 15mm or as per customer ordered
Wire lead	1 meter sheath cable or as customers order
Withstand Voltage	3000V
Operating temperature	-25°C~+70°C
IP class	IP65
Certification	CE recognized, RoHS Compliant

Model	Rated Amps	Class	Coil Length	Window Size A	Window Size B	Type No.
ESCT-RC16	100A	0.5	80	22	16	C
ESCT-RC24	300A	0.5	97	27.5	24	C
ESCT-RC36	600A	0.5	130	36	37	C
ESCT-RC60	500A	0.5	200	60	50	A
ESCT-RC100	1000A	0.5	395	135	100	B
ESCT-RC105	1500A	0.5	350	105	100	A
ESCT-RC150	3000A	0.5	525	165	150	B
ESCT-RC200	6000A	0.5	665	240	200	B
ESCT-RC240	10000A	0.5	800	245	240	A
ESCT-3RC16	100A	0.5	80	22	16	C
ESCT-3RC24	300A	0.5	97	27.5	24	C
ESCT-3RC36	600A	0.5	130	36	37	C
ESCT-3RC60	500A	0.5	200	60	50	A
ESCT-3RC100	1000A	0.5	395	135	100	B
ESCT-3RC105	1500A	0.5	350	105	100	A
ESCT-3RC150	3000A	0.5	525	165	150	B
ESCT-3RC200	6000A	0.5	665	240	200	B
ESCT-3RC240	10000A	0.5	800	245	240	A

Type A:	RC60	RC105	RC240
A.Windows Size A	60	105	245
B.Windows Size B	50	100	240
C.Coil O.D.	66	121	261
D.Coil Section	8		
E.Lead Cable Total Length	2000		
F.Coil Length	200	350	800

Type B:	RC100	RC150	RC200
A.Windows Size A	135	165	210
B.Windows Size B	100	150	200
C.Coil O.D.	151	181	226
D.Coil Section	8		
E.Lead Cable Total Length	2000		
F.Coil Length	395	525	665

Type c:	RC16	RC24	RC36
A.Windows Size A	22	27.5	36
B.Windows Size B	16	24	37
C.Coil O.D.	24	39.5	48
D.Coil Section	6		
E.Lead Cable Total Length	2000		
F.Coil Length	80	97	130

Type A:

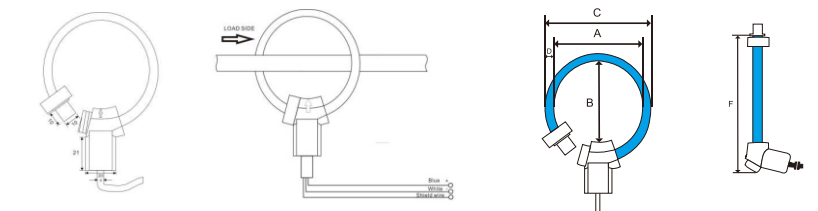

Type B:

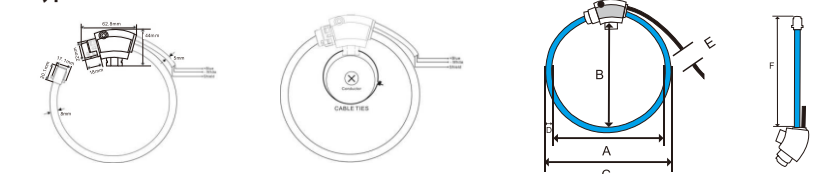

Type c:

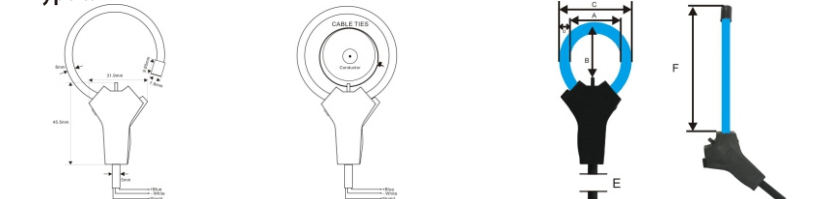



ESCT-ABO Series
SOLID CORE CURRENT TRANSFORMER

- Two built in fixing methods: 1 side base; Busbar mounting
- Built in hinged terminal cover
- Built in transparent cover for name plate
- Wide range accuracy (3,1,0.5,0.5s, 0.2,0.2s)
- Primary current from 50A to 3000A



ESCT-DM Series
SOLID CORE CURRENT TRANSFORMER

- Two built in fixing methods: 1 side base; Busbar mounting
- Built in hinged terminal cover
- Primary current from 50A to 300A

Specification	
Rated Frequency	50Hz-60Hz
Rated current	5A to 3000A loads
Rated output	5A, 1A, 0.5A, 0.25A, 0.1A
Accuracy	± 1% from 20% to 120% of rated current
Rated short-time thermal current (Ith)	60In
Rated voltage (Um)	1.2 In
Operating temperature	-10°C~50°C
Housing self-extinguishing class	VO
Standard	IEC60044-1, EN60044-1, VDE0414-44-1, GB1208-2006

Model	Ratio(A)	Burden (VA)	
		class 0.5	Class 1.0
ESCT-ABO-30	50/5	1.5	2.5
ESCT-ABO-30	60/5	1.5	2.5
ESCT-ABO-30	75/5	2.5	3.75
ESCT-ABO-30	100/5	3.75	5
ESCT-ABO-30	150/5	5	5
ESCT-ABO-30	200/5	5	5
ESCT-ABO-30	250/5	5	5
ESCT-ABO-30	300/5	5	5
ESCT-ABO-40	75/5	1.5	1.5
ESCT-ABO-40	80/5	1.5	1.5
ESCT-ABO-40	100/5	2.5	2.5
ESCT-ABO-40	150/5	3.75	5
ESCT-ABO-40	200/5	5	5
ESCT-ABO-40	250/5	5	5
ESCT-ABO-40	300/5	5	5
ESCT-ABO-40	400/5	5	5
ESCT-ABO-40	500/5	5	5
ESCT-ABO-60	200/5	5	5
ESCT-ABO-60	250/5	5	5
ESCT-ABO-60	300/5	5	5
ESCT-ABO-60	400/5	5	5
ESCT-ABO-60	500/5	5	5
ESCT-ABO-60	600/5	5	10
ESCT-ABO-60	750/5	5	10
ESCT-ABO-60	800/5	5	10
ESCT-ABO-60	1000/5	5	10
ESCT-ABO-100	800/5	5	10
ESCT-ABO-100	1000/5	5	10
ESCT-ABO-100	1200/5	7.5	10
ESCT-ABO-100	1500/5	7.5	10
ESCT-ABO-100	1600/5	7.5	10
ESCT-ABO-100	2000/5	10	15
ESCT-ABO-100	2500/5	10	15
ESCT-ABO-100	3000/5	10	15

► Introduction

ESCT-ABO perfect designed plastic case current transformer, advanced snap on body, high accuracy (up to Class 0.2S), humanization transparent cover and lead seal hole design makes the CT very easy to identify after long term use and perfect anti-stealing electricity.

► Dimension

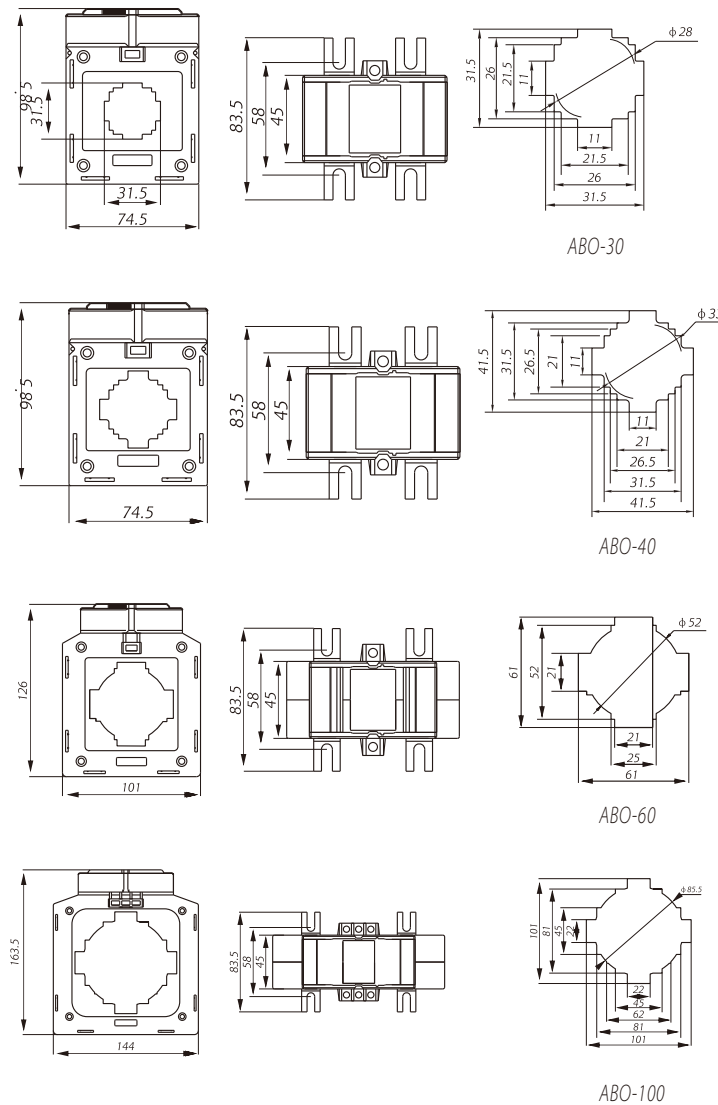

Specification	
Rated Frequency	50Hz-60Hz
Rated current	50A to 300A loads
Rated test voltage	3kV AC (1min)
Rated short-time thermal current (Ith)	60In
Rated voltage (Um)	0.72kV AC.
Rated output	5A or 1A
Rated voltage (Um)	1.2 In
Operating temperature	-10°C~50°C
Housing self-extinguishing class	VO
Safety factor	F5S
Standard	IEC60044-1, EN60044-1, VDE0414-44-1, GB1208-2006

Model	Rated Amps	Burden(VA)/Class 1.0
ESCT-DM-20/30	50/5	1
ESCT-DM-20/30	60/5	1.25
ESCT-DM-20/30	75/5	1.5
ESCT-DM-20/30	80/5	1.5
ESCT-DM-20/30	100/5	2.5
ESCT-DM-20/30	120/5	2.5
ESCT-DM-20/30	150/5	2.5
ESCT-DM-20/30	200/5	3.75
ESCT-DM-20/30	250/5	3.75
ESCT-DM-20/30	300/5	3.75
ESCT-DM-20/35	50/5	-
ESCT-DM-20/35	60/5	-
ESCT-DM-20/35	75/5	1.5
ESCT-DM-20/35	80/5	1.5
ESCT-DM-20/35	100/5	2.5
ESCT-DM-20/35	120/5	2.5
ESCT-DM-20/35	150/5	2.5
ESCT-DM-20/35	200/5	2.5
ESCT-DM-20/35	250/5	3.75
ESCT-DM-20/35	300/5	3.75

► Introduction

ESCT-DM is world famous MINI design plastic case current transformer, snap on body, be wildly used in generators. It is available for connecting with cable, and also available for connecting with Busbas. Its primary currents between 50A~300A with 5A secondaries with up to Class1.0 accuracy Performance.

► Dimension

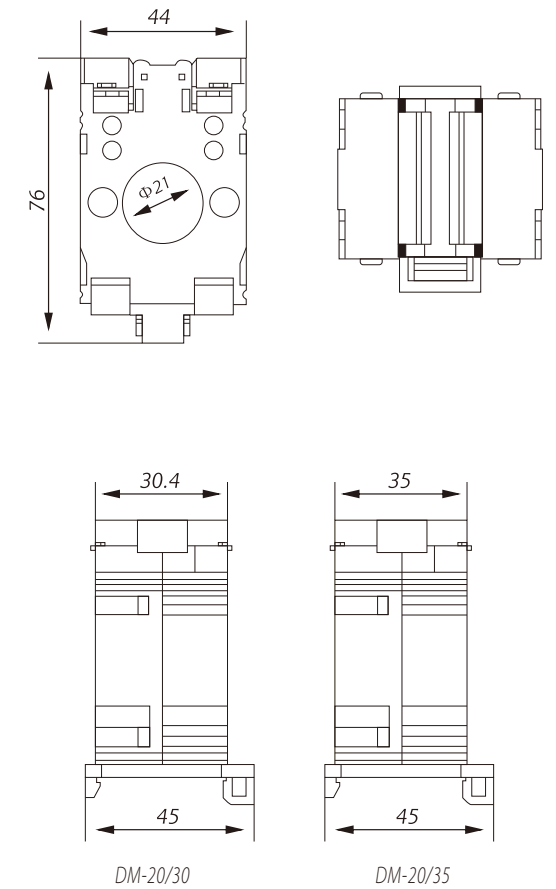



ESRD-TMS1/S2 MULTIFUNCTION TIME RELAY

- Microcontroller based
- 24 operating modes
- LCD display operating modes, set delay and operating time
- Time ranges : 0~9999s, 0~9999min
- AC/DC 24-240V supply voltage
- 2 independent NO contacts, controlled by different operating modes
- Backlighted LCD display
- Easy setting by keys
- 2 module Din rail mounting



ESRD-TPA1 SINGLE CHANNEL ASTRONOMICAL

- Digital time switch with astronomical program
- 3 year power reserve(lithium battery).
- Sealable cover of the front panel, easy setting by 4 keys.
- Automatic summer/winter time switchover
- LCD display, Holiday mode.
- Single channel
- Automatic transfer of weekdays
- 220-240V AC input supply.
- Double-modules, mounted on TH-35 rail.

Specification	
Supply terminals	A1,A2
Pulse terminal	S
Supply voltage	AC/DC 24-240V
Rated frequency	50/60Hz
Time range	0~9999s, 0~9999min
Repetition accuracy	max.±3s/24h 25°C
Data readout	Back-lighted LCD display
Data storage	10 years
Output contacts	1 C/O +1 NO
Current rating	8A/ AC1
Contacts capacity	AC-15:2A
Insulation voltage	250V
Protection degree	IP20
Pollution degree	3
Electrical life	10 ⁵
Mechanical life	10 ⁶
Altitude	≤2000m
Ambient temperature	-5°C~+40°C
Storage temperature	-10°C~+50°C
Wire size	0.5mm ² ~1mm ²
Torque	0.5Nm
Mounting	TH-35 DIN-Rail

► Description

○ Panel ○ Symbol legend

● — Output relay ON
 ○ — Output relay OFF
 R 1 — Output relay 1
 R 2 — Output relay 2
 SET — Parameters setting
 ONStart — Starting with ON
 OFFStart — Starting with OFF
 ⌋ — Time impulse release by rising edge
 ⌋ — Time impulse release by falling edge
 min — Set time: minute
 sec — Set time: second
 T — Time delay T
 T1 — Time delay T1
 T2 — Time delay T2
 start — Starting with S pulse

○ Enter configuration menu
 ○ Exit configuration menu
 ○ Select menu
 ○ Digit +
 ○ Display menu selection

○ Confirm settings
 ○ Select menu
 ○ Digit -
 ○ Display menu selection

► Wiring diagrams

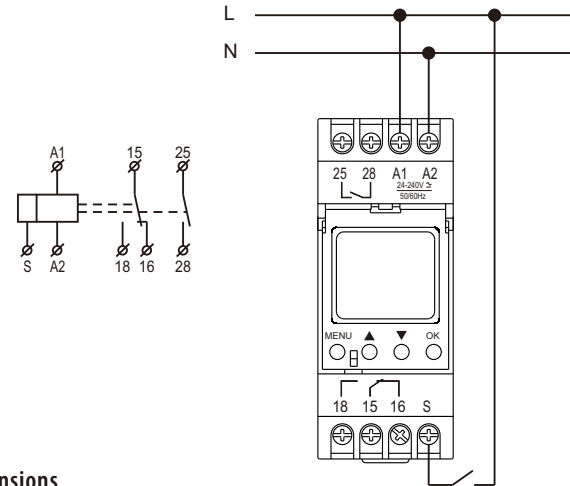

► Dimensions

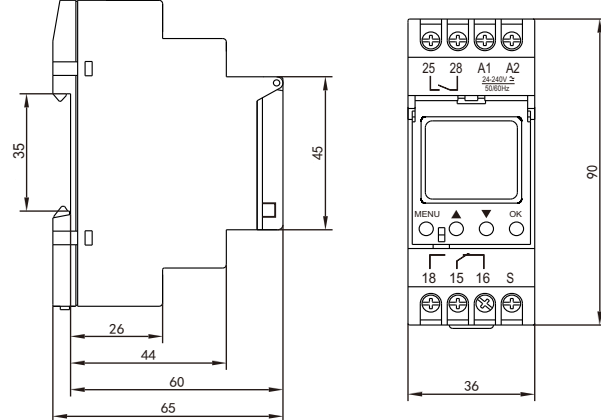

► Front-face panel

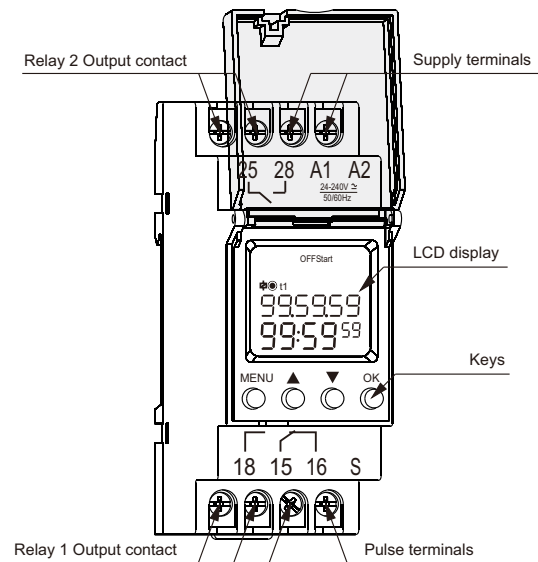

Specification	
Supply terminals	A1-A2
Rated voltage	AC220-240V
Rated frequency	50/60Hz
Power consumption	1W
Supply voltage tolerance	± 10%
Number of channels	1
Program	astronomical
Mode of work	manual, automatic, holiday
Summer/winter time	off, automatic changes
Time tolerance	≤ 1s/day at 20°C
Power reserve	3 year
Data readout	LCD display
Number of contacts	1 C/O
Current of contacts	16A/250V AC1
Switching capacity	4000VA/AC, 384W/DC
Electrical life	10 ⁶
Mechanical life	10 ⁵
Rated insulation voltage	250V
Protection degree	IP20
Pollution degree	3
Altitude	≤ 2000m
Ambient temperature	-30°C~55°C
Permissible relative humidity	≤ 50%(40°C, without condensation)
Storage temperature	-35°C~70°C
Wire size	1mm ² ~ 4mm ²
Tightening torque	0.5Nm
Mounting	TH-35 Rail(EN60715)
Dimensions	90*36*64mm
Standard	IEC60947-1/IEC60947-2-7

► Front-face panel

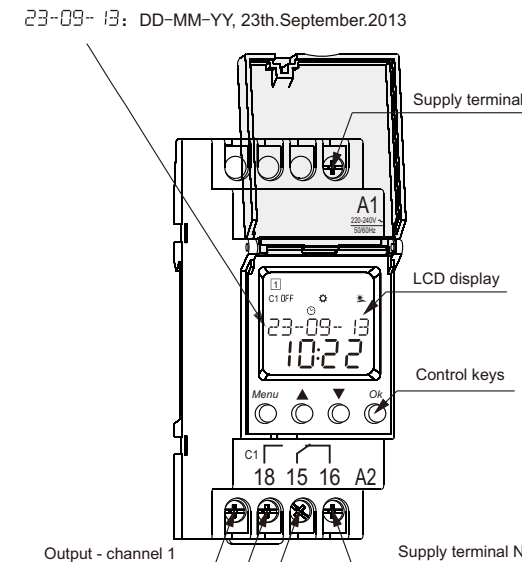

► Description

○ Panel 1 2 3 4 5 6 7 — Days of the week Monday, Tuesday, ...Sunday

C1 — Channel 1
 On OFF — Relay status: On Activate, OFF Deactivate
 ☀ — Automatic mode
 ☀ — Manual mode
 ☀ — Holiday mode
 ☀ — Sunrise
 ☀ — Sunset
 ☀ — Winter time
 ☀ — Summer time
 Prog — Program setting

○ Enter main menu
 ○ Back to main menu
 ○ Select menu
 ○ Increase a numerical value
 ○ C1 manual operation

○ Confirm selection
 ○ Select menu
 ○ Decrease a numerical value

► Wiring diagrams

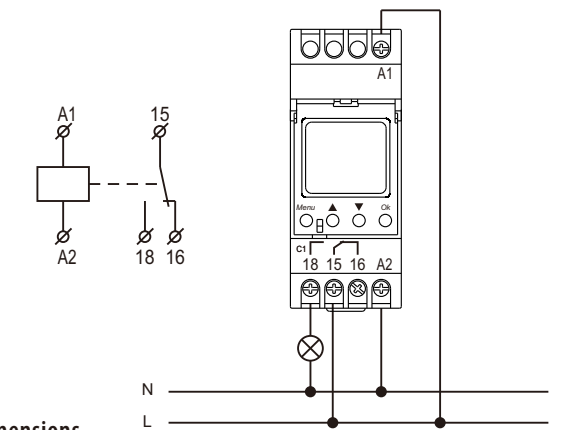

► Dimensions

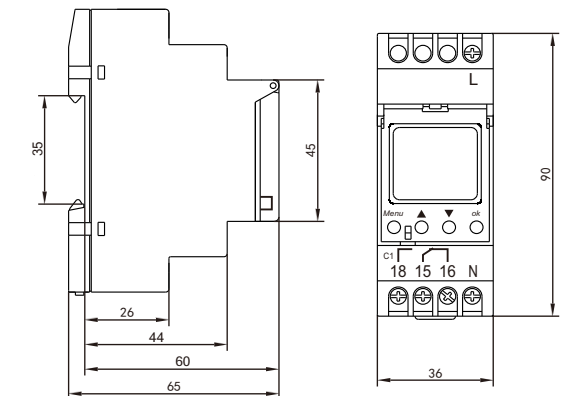



ESRD-TPW1/2
DOUBLE CHANNEL DIGITAL WEEKLY

- Digital time switch with weekly program
- 10 year power reserve(lithium battery)
- Sealable cover of the front panel, easy setting by 4 keys
- Automatic summer/winter time switchover
- Back-lighted LCD display,Holiday mode
- Double channels
- Automatic transfer of weekdays
- 24-264V AC/DC input supply
- Double-module, mounted on TH-35 rail



ESRD-ST1
TWILIGHT SWITCH

- Modular design, 36mm wide housing.
- Sensitivity adjustment from 2 to 100 lux
- Eternal light sensor included in delivery
- Fixed switching on and off delay
- LED indication for power supply and relay status
- DIN Rail mounting

Specification	
Supply terminals	A1-A2
Rated voltage	AC220-240V
Rated frequency	50/60Hz
Power consumption	2W
Supply voltage tolerance	± 10%
Number of channels	Double channels
Number of programs	100
Program	weekly program, daily program
Operating modes	manual, automatic, holiday
Summer/winter time	off, automatic changes
Time tolerance	≤ 1s/day at 25°C
Power reserve	10 year
Data readout	LCD display with backlight
Number of contacts	2 C/O
Current of contacts	16A/250V AC1
Switching capacity	4000VA/AC1, 384W/DC
Mechanical life	10 ⁶
Electrical life	10 ⁵
Rated insulation voltage	250V
Protection degree	IP20
Pollution degree	3
Altitude	≤ 2000m
Ambient temperature	-20°C~55°C
Permissible relative humidity	≤ 50%(40°C,without condensation)
Storage temperature	-30°C~70°C
Wire size	1mm ² ~4mm ²
Tightening torque	0.5Nm
Mounting	TH-35 Rail(EN60715)
Dimensions	90*36*64mm
Standard	IEC60947-1/IEC60947-2-7

Description

1 2 3 4 5 6 7 — Days of the week Monday, Tuesday, ...Sunday

C1 — Channel 1
C2 — Channel 2
On OFF — Relay status
⌚ — Automatic mode
⏸ — Manual mode
🏠 — Holiday mode
❄ — Winter time
☀ — Summer time
Prog — Program setting

Menu: Enter main menu, Back to main menu
Ok: Confirm selection
⬆: Select menu, Decrease a numerical value
⬆: Select menu, Decrease a numerical value
⬆: C1 manual operation, ⬆: C2 manual operation

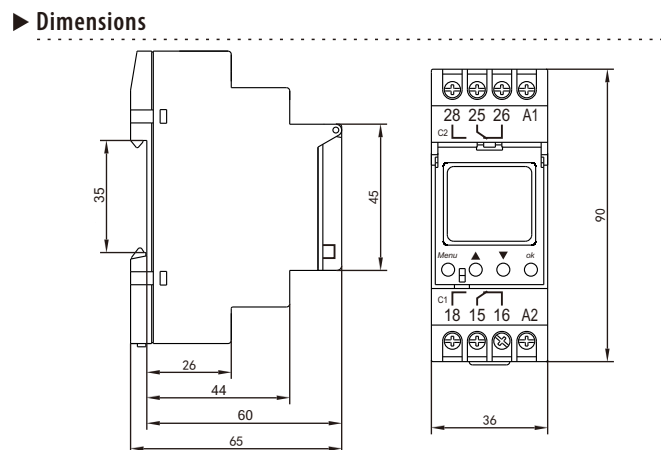
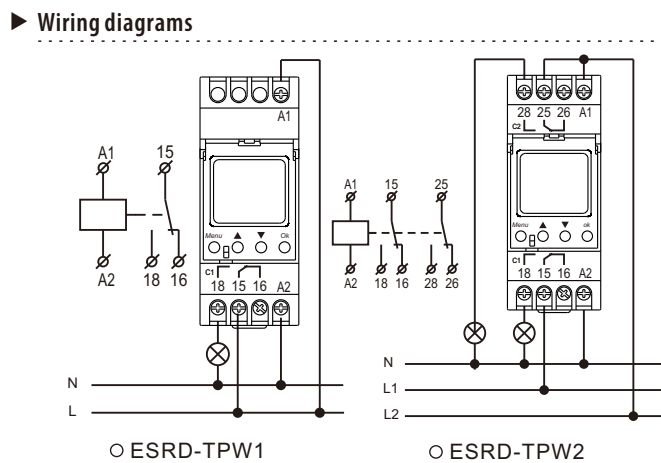

Specification	
Rated control voltage	AC220V
Frequency	50/60Hz
Sensitivity threshold	2~100lux adjustable
Switch-on delay	2-5s
Switch-off delay	10-15s
Hysteresis (switching off/on ratio)	1.20
Output contact	1NO
Current rating	25A/250V AC1
Incandescent lamp load	3000 W
Halogen lamp load	3000 W
Fluorescent lamp load (compensated)	1000 W
Fluorescent lamp load (uncompensated)	1300 W
Protection degree	Terminal: IP20, Sensor: IP65
Ambient temperature	-25°C~+40°C

Front-face panel

Output contact, Supply terminal, Supply indication (yellow), Output indication (red), Sensitivity adjustment, Sensor input terminal

1. Connect the sensor ST110.
2. Set the sensitivity.
3. When the strength of light goes below set sensitivity value, output indication LED lights up and the delay begins. After the switch on delay, switch energizes its contacts. Delay can avoid any command caused by temporary illumination or headlights

When the strength of light goes above the hysteresis value, output indication LED goes out and the delay begins. After the switch off delay, switch de-energizes its contacts.

Hysteresis= 1/4* set sensitivity value

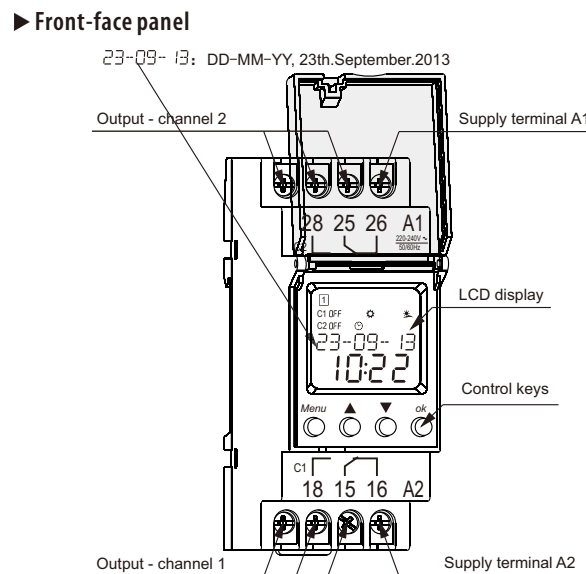
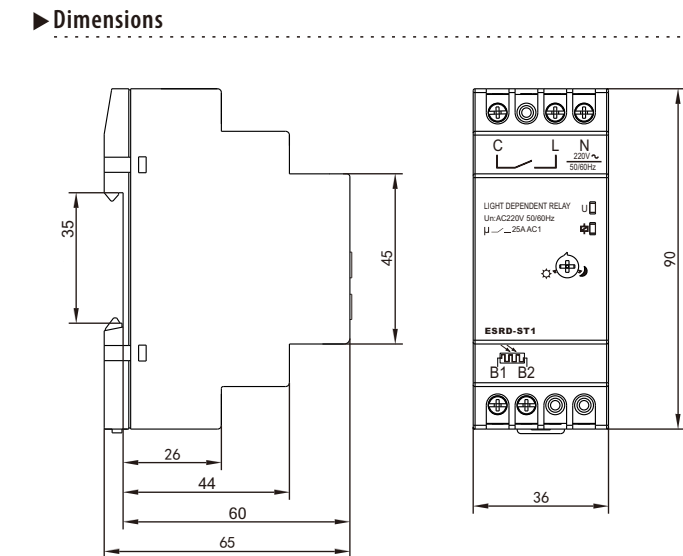
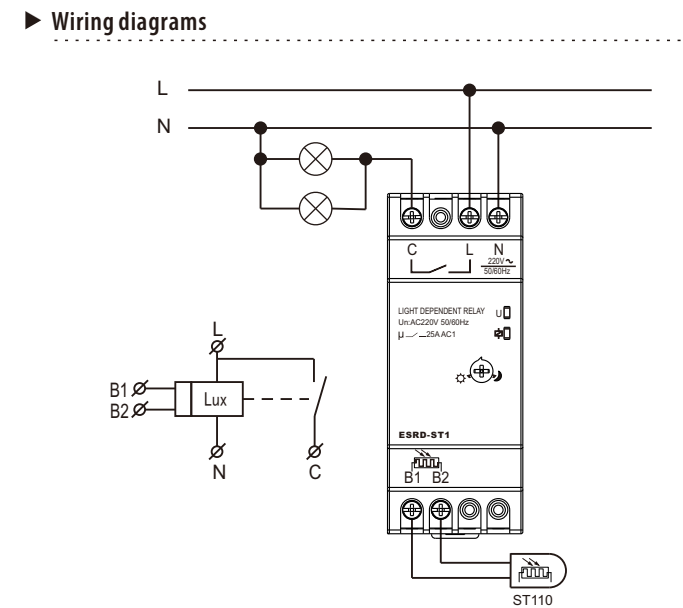
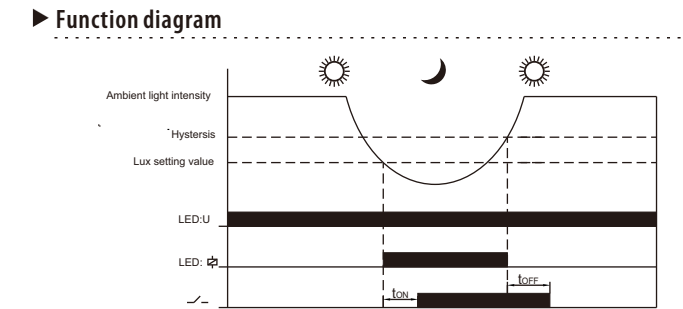



ESRS-TM11/12/14/23 MULTIFUNCTION TIME RELAY

- Microcontroller based
- Modular design, 18mm wide housing
- 10 operating modes
- 10 time ranges(1s, 10s, 1m, 10m, 1h, 10h, 1d, 10d, ON, OFF)
- 1 changeover contact
- LED indication for power supply and relay status
- DIN-Rail mounting

Specification		
Models	ESRS-TM11/14/23	ESRS-TM12
Supply terminals	A1,A2	A1,A2,A3
Pulse terminal	S	
Supply voltage	AC 220V	A1-A2: AC 220V A3-A2: AC/DC 24V
Rated frequency	50/60Hz	
Time range	0.1s-10days	
Setting accuracy	<5%	
Repetition accuracy	<0.2%	
Output contacts	1 C/O	
Current rating	8A /AC1	
Contacts capacity	AC-15: 2A	
Insulation voltage	250V	
Protection degree	IP20	
Pollution degree	3	
Electrical life	10 ⁵	
Mechanical life	10 ⁶	
Altitude	≤2000m	
Ambient temperature	-5°C~+40°C	
Storage temperature	-10°C~+50°C	
Wire size	0.5mm ² ~1mm ²	
Torque	0.5Nm	
Mounting	TH-35 DIN-Rail	

► Description

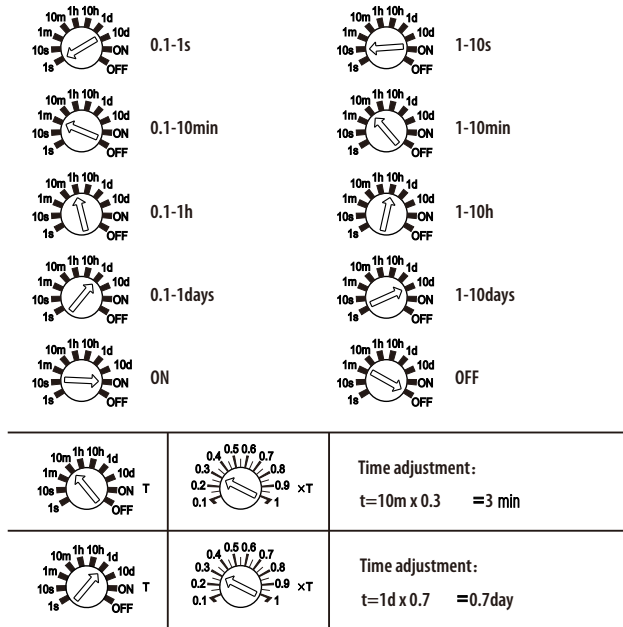

► Wiring diagrams

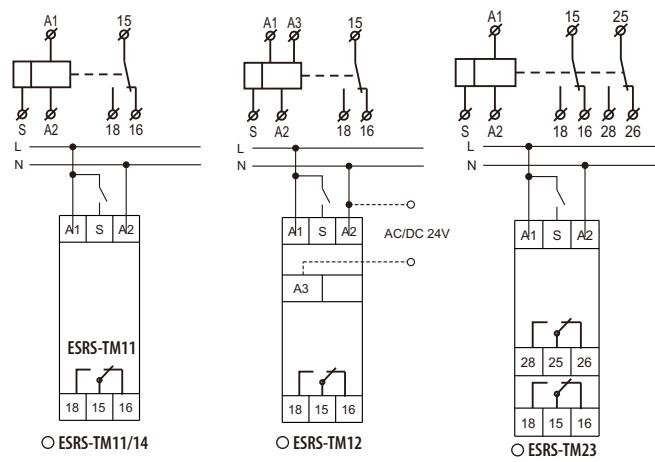

► Dimensions

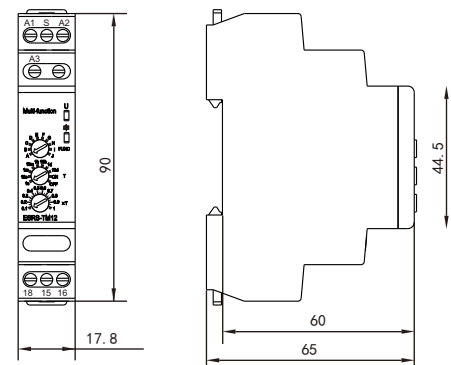

ESRD-TSL Series STAIRCASE LIGHTING TIME

- Microcontroller based
- Modular design, 18mm wide housing
- Possibility of 3 wire or 4 wire connection
- ON, OFF, AUTO three operation modes
- Repetition accuracy < 0.2%
- LCD indication for relay status
- DIN-Rail mounting

Specification	
Rated supply voltage	AC230VAC, 50/60Hz
Type of contact	1NO(AgNi)
Rated current(Ith)	10A
Power consumption	≤1.5VA
Incandescent lamp load	2000W
Fluorescent lamp load, lead-lag circuit	1000W
Fluorescent lamp load, inductive-capacitive	1000W
Fluorescent lamp load, parallel compensated	650W
Inductive load, cosφ=0.6@230V	650W
Mechanical life	10 ⁵
Electrical life	10 ⁶
Time range	0.5-20m
Setting accuracy	≤5%
Repetition accuracy	≤0.2%
Maximum load of illuminated switch	50mA
Reset time	≥200ms
Altitude	≤2000m
Protection degree	IP20
Pollution degree	3
Ambient temperature	-5°C~+40°C
Storage temperature	-25°C~+75°C

► Front-face panel

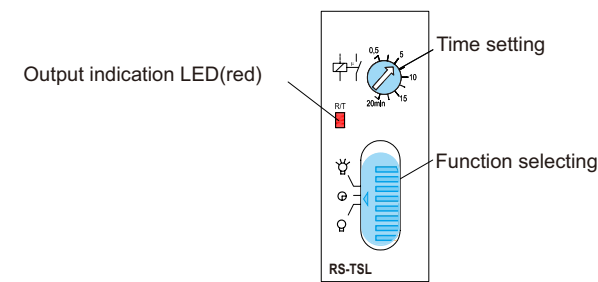

► FUNCTION DIAGRAM

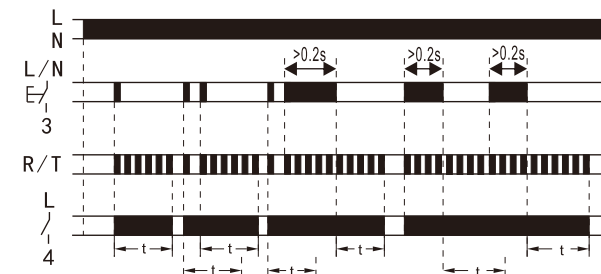

► Wiring diagrams

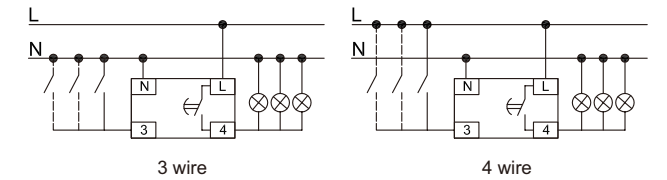

Example of application

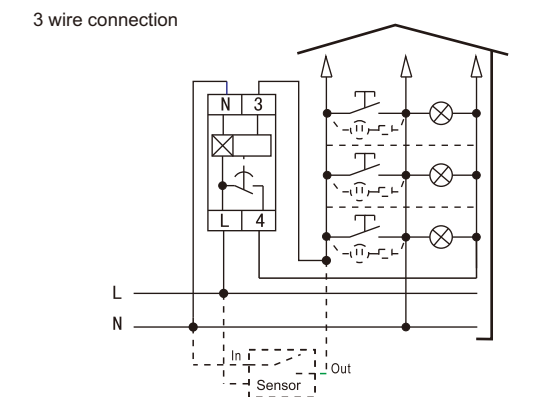

4 wire connection

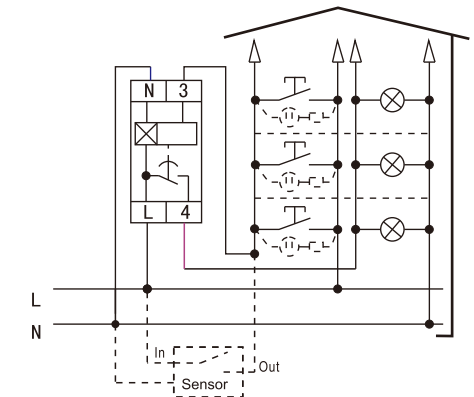

► Dimensions

