



200A Smart Programmable Voltage Sensitive Relay Part 0-727-43

WARNINGS

Before using this unit please read these instructions carefully. Take special care to follow the warnings and safety suggestions listed below. Keep these instructions for future reference. There are no user-serviceable parts within the unit, refer servicing to qualified service personnel.

GENERAL

The Durite Smart Relay has been designed to be used with the latest range of vehicles fitted with smart alternators and regenerative braking systems. In addition, there are 9 available programmes allowing the user to set the charging/protection voltages to suit their requirements. Therefore, the Smart Relay is suitable for use either for charging of a secondary / accessory battery or for protection of the main battery from a particular high drain circuit. Additionally, it has the facility for a manual override allowing both batteries to be used to start the engine or to make safe a piece of equipment on the protected circuit before power is lost.

INSTALLATION INSTRUCTIONS

Terminal 30 to main battery +12V
Terminal 87 to secondary battery or separate circuit +12V
Terminal 85 to ground or -0V
Terminals 86 is used for programming or override function

OVERRIDE FUNCTION

Connect terminal 86 through a momentary switch (not supplied) to terminal 30. When the switch is operated and the circuit is made the unit will make the connection between terminals 30 and 87 for 30 seconds from when the switch is released.

PROGRAMMING FUNCTION

To enter programming mode, the power must be off to terminal 30 and terminal 85 must be connected to ground or -0V.
Connect terminal 86 to terminal 30 and then re-connect the power to terminal 30. The LED on the top of the unit will flash a number of times indicating the current programme number (once for 1, twice for 2, Etc.).
Remove and replace, within 40 seconds, the connection to terminal 86 and the LED will start to sequence through the programme numbers (once for 1, pause, twice for 2, pause, Etc.). When the number of the programme required is reached remove the connection to terminal 86.

The LED will flash the number of times to confirm the programme number selected.
 If this is OK re-connect terminal 86 and the LED will flash quickly indicating that the setting is saved. (If not OK turn the power off and start again.)
 Turn the power off.
 When the power is turned back on the unit will use the last programme set.

Programme	Switch off	Delay	Switch on after 5 Seconds	
1	10V	5 Seconds	11.5V	
2	11.71V	5 Seconds	13.2V	
3	10.5V	5 Seconds	12.0V	
4	10.5V	5 Seconds	12.8V	
5	11.25V	5 Minutes	13.25V	
6	11.5V	5 Minutes	12.8V	FactorySet
7	11.5V	5 Minutes	13.8V	
8	11.8V	5 Minutes	12.8V	
9	12.8V	5 Minutes	13.2V	

DIMENSIONAL DRAWING

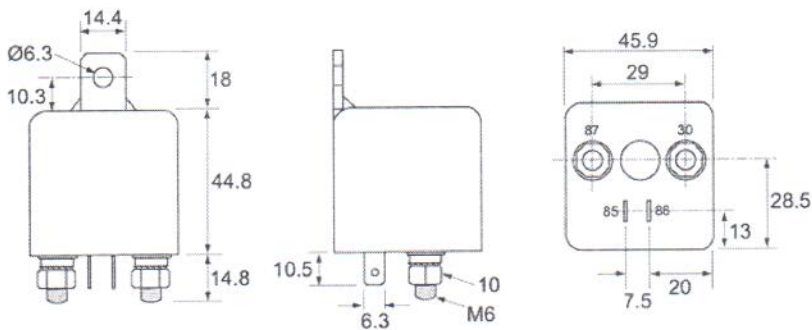

SPECIFICATION

Nominal Voltage.....12V
 Maximum Voltage.....16.5V
 Voltage Sensing.....Primary Battery Only
 Maximum Current.....200A
 Standby Current.....2mA
 Dimensions.....Please see dimensional drawing
 Weight140g
 Terminals.....2 x M6 bolts + 2 x 6.3mm blades



www.durite.co.uk

0-727-43-LEAF