

## Intafil "Slimline"

### Compact all-in-one solution for sealed systems

#### Introduction

"Slimline" compact expansion vessel, with an all in one solution and unique five-way connector allows for easy and convenient installations, where space is limited.



- Slimline compact design allows for installation where space is limited
- Compact, all-in-one solution for sealed heating systems
- Fixed wall bracket permits left or right installations
- Unique five-way connection provides the most flexible installation available
- 360° fully rotatable safety relief valve
- Compression joints allow direct connection to pipework
- Ideal for both new and retro-fit installations
- Available in 8, 12, 18 and 24 litre capacity vessels
- Complies fully with G24.1 and G24.2 of the water regulations



360° Fully Rotatable



Wall Bracket

#### Product Range

Description	Code
8 Ltr Compact Intafil Sealed System Kit	IFS08
12 Ltr Compact Intafil Sealed System Kit	IFS12
18 Ltr Compact Intafil Sealed System Kit	IFS18
24 Ltr Compact Intafil Sealed System Kit	IFS24

## Intafil "Slimline"

### ▀ Dimensions

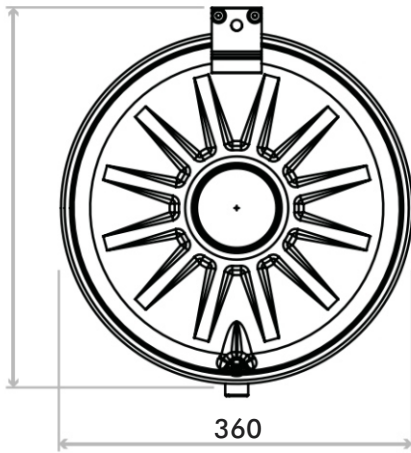

8 Litres

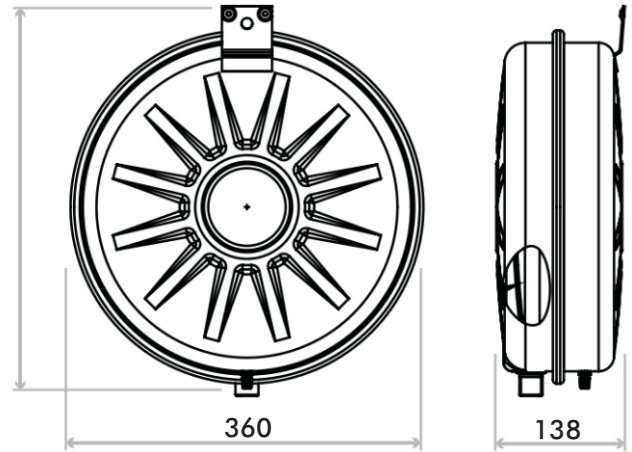

12 Litres

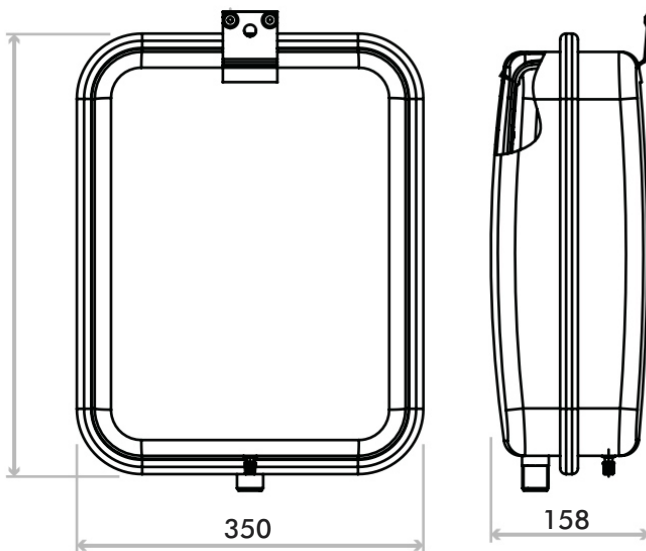

18 Litres

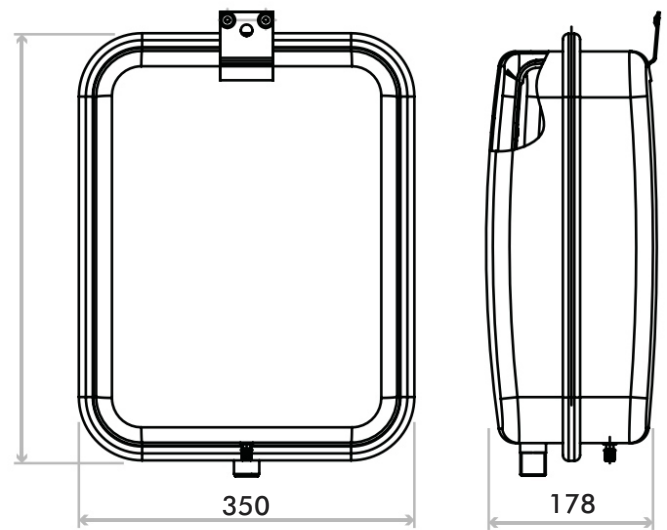

24 Litres

AIRFIELD INDUSTRIAL ESTATE, HIXON, STAFFORD, ST18 0PF  
T. 01889 272180 F. 01889 272181 SALE@INTATEC.CO.UK  
WWW.INTATEC.CO.UK