



AEL.TF.32
INTRODUCTORY AND OPERATING MANUAL
THREE-PHASE ACTIVE
ELECTRONIC ELECTRICITY METERS

CE 0122

CONTENTS

Part Name	Page No
0. Introduction.....	1
1. Introduction Technical Specifications of the Electricity Meter.....	2
2. Main Functions.....	3
3. Structure And Operation Principle Of The Electricity Meter.....	4
4. Starting-Up The Electricity Meter.....	4
5. LCD Monitor Indicators.....	5
6. Connection Diagram.....	8
7. Diagram for assemblage measurement And Seal Points.....	8

0. INTRODUCTION

Electronic electricity meters which are;

in compliance with the Measuring Instruments Directive 2014/32/EU, published by European Union and is within the scope of new approach regulation can measure active electric energy and drawn maximum power and display this data on LCD screen, Can realize day light saving time during summer and winters automatically, can save required information and programs in the memory, and accessible when required, and technical information of these meters which are manufactured with advanced technology are being described within this operating manual.

WARNING!

BEFORE ASSEMBLY OF THE ELECTRICITY METER READ THIS MANUAL CAREFULLY.

- The electricity meter should be mounted only by **licensed qualified personnel**.
- During mounting, avoid contact with the **parts with voltage**.
- During mounting and dismounting the electricity meter, **the power should be cut off**.
- KHLSM Electronic electricity meters are high-tech products. Any and all technical data and documents are under intellectual property of the Company; they may neither be reproduced nor used by third parties.
- This booklet provides summarized information about the electricity meter.
- Prior to assembly, qualified personnel should check whether the electricity meter type to be mounted is or is not in compliance with the electric supply system and electrical installation. Otherwise, the mounted electricity meter may be damaged because of faulty selection and connection of electricity meter. **Such electricity meters shall not be assessed under the guarantee.**

1. TECHNICAL SPECIFICATIONS OF THE ELECTRICITY METER

Type	AEL.TF.32
Name	3 Phase 4 Wire, 4 Tariff, Demand Measuring, Outdoor, Active Electronic Electric Meter
Class	B
Reference Voltage (Un)	3x230/400V
Reference Frequency (Fn)	50 Hz ±%5
Starting Current (Ist)	20mA (0,04.Itr)
Minimum Current (Imin)	0,25A
Transition Current (Itr)	0,5A
Reference Current (In)	5A
Maximum Current (Imax)	100A
Operating Voltage Range	From 0,8Un to 1,15Un
IP Class	IP54 (Outdoor)
Protection Class	Two (2)
Relative Humidity Ratio	%95
Operating Temperature	-40°C, +70°C (3K7)
Connection	Direct
Mechanical Environment	M1 (2004/22/EC Directive)
Electromagnetic Environment	E2 (2004/22/EC Directive)
User Environment	For Non-Condensing Humidity Environment
Power Consumption in Voltage Circuit	≤ 2W, ≤10VA
Power Consumption in Current Circuit	≤ 4VA
ESD Voltage Resistance	Contact Discharge : 8 kV Air Discharge : 15 kV
Pulse Voltage	6 kV
Meter Constant	1000 imp/kWh,
LCD Display	6+3 Digit
Communication Speed	300-4800 Baud (IEC 62056-21)
Interface Unit	Optik Port (IEC 62056-21)
Battery Life of the System	≥ 10 year
Real Time Clock Battery Life	≥ 10 year
Shelf Life of the Electricity Meter	≥ 4 year
Time Clock Accuracy	0,5 s/day (at room temperature) (IEC-EN 61038)
Data Storage Capacity	1 year
Related Standards	EN 50470-1, EN 50470-3

Percentage Error Limits at Reference Conditions

Current Range	Power Factor	Percentage Error Limit (%)
0,5A < I < 1A	1	± 1,5
1A < I < 80A	0,5 ind....1.....cap 0,8	± 1

2. MAIN FUNCTIONS

- **Programming the Electricity Meter:** On the electricity meter, the date and time, tariff data may be adjusted by the authorized personnel by opening the lid of electric terminal box.
- **Reading the Electricity Meter:** Invoicing data for 12 months, consumed total power amount, data about lid openings of electric terminal box, demand data for 6 months and initial opening date of upper lid can be read on optic port of the electricity meter.
- **Auto Trouble-Shooting Feature:** The electricity meter continuously controls its internal circuits and displays in the menu of its monitor the trouble types shown hereunder.



The Upper Lid is
Open Warning



The Lid of Electric Terminal
Box is Open Warning



Battery of the System
is Warning



Battery of the Clock is
Weak Warning



Clock Error

- **Electric Terminal Box Lid and Upper Lid Opening, Closing, Recording Features:** When the upper lid is opened, the first opening date is stored. When the lid of electric terminal box is opened, the first opening date of each month and total of openings throughout the relevant month is stored. Lid opening dates and numbers of the most recent 12 months are stored in the memory.
- **Communication:** The data is transmitted to a portable computer (indexor) through an optical reader from optic port of the electricity meter.
- **Signal Output:** On the electricity meter, there is two LEDs so as to indicate the consumed active energy. Numbers of blinks of these LEDs shows Imp/kWh values of the electricity meter.
1000 Imp/kWh : 1000 Blinks = 1 kWh
- **Summer/Winter Day Light Saving Time:** The electricity meter automatically switches to summer / winter day time light saving time.
- **Displaying during Power Failure:** When the power is cut, the data requested can be brought to the LCD monitor via the call-button on the electricity meter and reading can be taken from optic port.

3. STRUCTURE AND OPERATION PRINCIPLE OF THE ELECTRICITY METER

3.1. Structure of the Electricity Meter

Casing and lids of the electricity meter are in compliance with IP54 Outdoor Standard and fully sealed. The electricity meter is made of high-grade nonflammable plastics (PVC). All electronic components are laid on a special PCB card; and these cards are mounted to the casing of the electricity meter.

3.2. Block Diagram of Operation

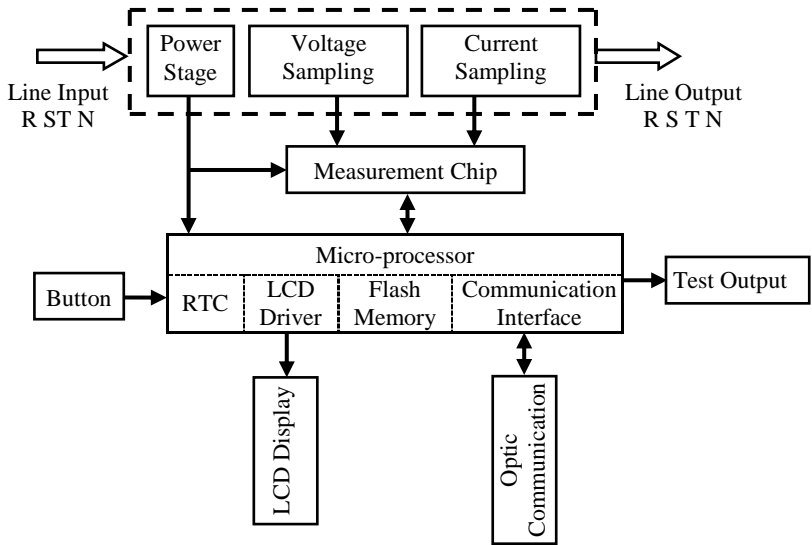

4. STARTING-UP THE ELECTRICITY METER

Normally the electricity meter as well as the LCD monitor operates, when the meter is mounted and powered on.

4.1. Controlling the Functions

Once the electricity meter is mounted, its electrical connections should be checked whether they are proper or not. After the electricity meter mounted properly to its place, the screw on the lid of the electric terminal box should be tightened. 2nd lock indicator blinking on the LCD monitor will disappear after the first reading. If not, then it means either the lid of the electric terminal box is not attached properly or its screw is not tightened well.

4.2. Operation of the LCD Monitor

Following initial operation of the electricity meter, the auto-display mod will activate. Each menu of the display will be displayed for 5 seconds and then automatically proceed to the next informative menu. When the button on the electricity meter is pushed down, the button menu mod will activate and the data on the monitor will be stay for 1 minute on the monitor. After 1 minute it return to the auto-display mod.

5. LCD MONITOR INDICATORS

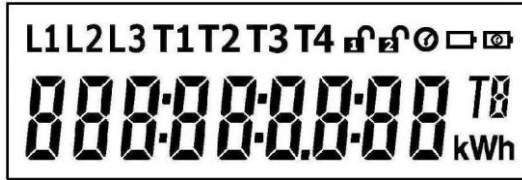

Definitions of the symbols and indicators on the LCD Monitor are as follows:



The Upper Lid is Open

This symbol indicates that the upper lid is opened. If the indicator is blinking while the lid is close, then it is indicating that the lid is opened earlier. If the indicator is being displayed on the monitor continuously, then the upper lid is on open position.



The Lid of Electric Terminal Box is Open :

This symbol indicates that the lid of the electric terminal box is opened. If the indicator is blinking while the lid is close, then it is indicating that the lid is opened earlier. If the indicator is being displayed on the monitor continuously, then the lid is on open position. Symbol will disappear after the electricity meter is read.



Clock Error: If the clock does not operate normal, this symbol will be displayed.



Battery of the System: If the voltage of the battery of the system is low, this symbol will be displayed.



Battery of the Clock: If the voltage of the battery of the clock is low, this symbol will be displayed.

T1 T2 T3 T4

Tariff display: These symbols indicate the timely using active tariff period of the electricity meter.

T8

These symbol indicate currently reading active tariff on the monitor.

kWh

These symbol indicate the active energy unit.

L1 L2 L3

L1, L2 and L3 symbols indicate existence of, respectively, **R, S and T** phases. Using by the three-phase electricity meters.

5.1 Samples from Display List

Data Menu

T1
20 10:03:18

Hour Menu

T1
10:03:16

Total Active Energy

T1
0 14538.968^T kWh

Active Energy on the T1
Tariff

T1
005532.757^{T1} kWh

Maximum Demand
Within the Month

T1
008.357 P
kW

Demand Date

T1
20 10:0 1:02 P

Demand Hour

T1
07:02 P

Version of the Programm

T1
PR06:0007

Test Display

L1L2L3T1T2T3T4 ⏏ ⏏ ⏏ ⏏
888:88:88:88 T8
kWh

6. CONNECTION DIAGRAM

Inner diameter of phase and neutral sleeve of AEL.TF.32 5(100)A three-phase electricity meters is 6,3mm. If this electricity meter will be connected to a line of 100 Ampere, the cross section of copper and conductive part of line cable should at least be 25mm².

The connection diagram of AEL.TF.32 three-phase electricity meter is given below.

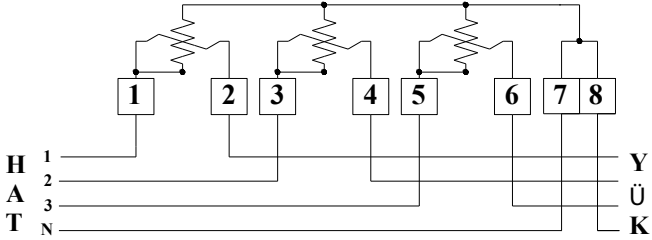

7. DIAGRAM FOR ASSEMBLAGE MEASUREMENT AND SEAL POINTS

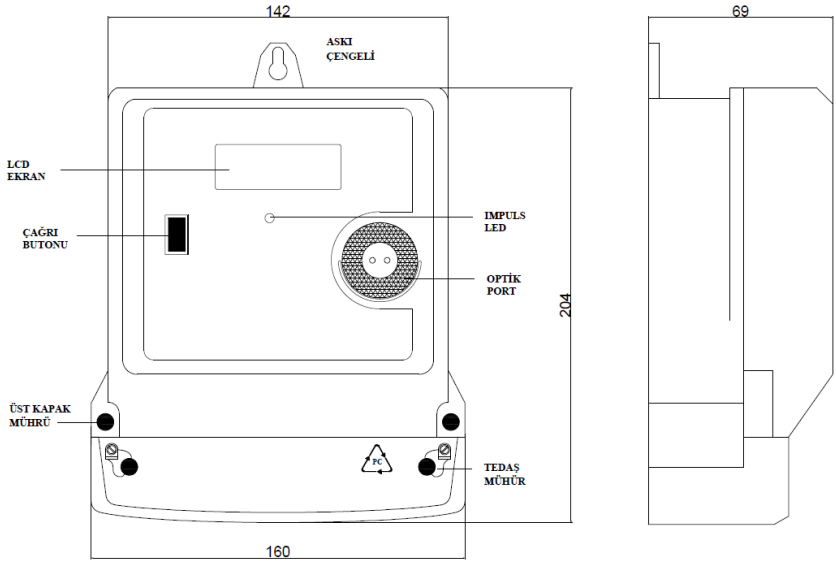



1 Church Lane,
Normanton,
West Yorkshire,
WF6 2DE

01924 891049

www.smartelectricitymeters.co.uk