

SolarCache+

the PV energy use maximiser

Installation Manual



(SolarCache+Duo Plus display shown)



The system should be installed only by a suitably qualified person

We recommend that you read right through these instructions before you begin, but in summary:

1. **Inspection**
Assess the existing electrical wiring to make sure that it is suitable for the installation of **SolarCache+**.
2. **Mounting**
Mount the **SolarCache+** controller and power throttle in suitable locations.
3. **Wiring**
Make connections as shown below in Figures 1 to 5. Leave the current transformers unclipped for now.
4. **Commissioning**
Electrically test the circuitry and then energize the system.
Carry out the commissioning steps as described below.
5. **Handover**
Remember to give the User Instructions to the householder, and demonstrate how the system works.

General information

SolarCache+ measures how much power is flowing through the electricity meter using a *current transformer* which clips around the live wire of the feed from the Grid. When there are more than 50 Watts being exported, it brings up the immersion heater (water heater), always adjusting the exact level so as to maintain the exported power below about 200 Watts. Electric appliances can be turned on and off in the house and *SolarCache+* makes the appropriate adjustment. *SolarCache+Duo Plus* and *Wi-Link* versions also measure the amount of power being generated by the PV installation using a second clip-on current transformer. This information is displayed, but has no effect on the control of the water-heater.

What's in the box?

	<i>SolarCache+ Mono</i>	<i>SolarCache+ Duo Plus</i>	<i>SolarCache+ Wi-Link</i>
controller unit	1	1	1
wired power throttle	1	1	-
wireless power throttle	-	-	1
CT clips with phono plug terminations	1	2	2
control signal cable with phono plug	1	1	-
power supply cable with power plug	1	1	-
5-core cable	1.5m	1.5m	-
PVC cable glands	1	1	-
mounting screws for the controller	4	4	4
AC power supply	-	-	1

Please identify each of these components. Call 01223 440100 if there is a discrepancy.

You will also need screws and the appropriate wall fixings for the power throttle.

1 Inspect the wiring

SolarCache+Mono and *SolarCache+Duo Plus*: assess the existing immersion heater circuit to ensure that it is a dedicated radial circuit fed directly from the consumer unit. Any other equipment which is also connected to this circuit must be disconnected and re-wired.

SolarCache+Wi-Link: the power throttle may be fitted next to the immersion heater in the airing cupboard, by-passing any spurs already connected to the circuit between the consumer unit and the immersion heater.

We recommend that the *SolarCache+* controller and associated AC circuitry is protected by a 30mA RCD. Our modular design allows the controller unit to be mounted away from the consumer unit in a more convenient position so that the display can be seen at a glance with ease.

2 Mount the power throttle

SolarCache+Mono and *SolarCache+Duo Plus*: the power throttle should be installed adjacent to the property's main consumer unit, and incoming electrical supply.

SolarCache+Wi-Link: the power throttle can be installed next to the immersion heater in the airing cupboard, or connected anywhere between the immersion heater spur and immersion heater.

Please note that there are separate wiring diagrams and instructions for each version.



The power throttle may run hot at times! Mount the unit on a non-flammable vertical surface and make sure that air is free to run through the vents. If in doubt, we recommend spacing the power throttle from the wall surface by 10 mm.



Inspect the existing immersion heater integral thermostat to ensure that it complies with safety requirements and regulations to provide thermal overload protection where the hot-water system includes a plastic header tank. Replace the thermostat if necessary.

3 Mount the control unit

Remove the lid by gently pressing in the centre of the upper side of the base. The cover will release from the top, hinging at the bottom. Refit the lid by aligning the two locators at the bottom, gently pushing home at the top.

Mount the controller unit carefully on a flat surface so as not to distort the enclosure. Failure to do this may result in damage to the unit and poor fitting of the cover.

The cable entry slot is designed to allow the power and phono cables to be threaded through from the rear or from the bottom. The plugs may be inserted into their respective sockets prior to final fixing. We recommend that you first prepare and loosely fix the unit to the wall, and then, before tightening the fixings, thread the plugs through the cable entry slot and insert them into their respective sockets, starting at the top and working down. There should be no need to make additional holes in the base.

Figure 1 showing the controller unit

*SolarCache+
Mono*

*SolarCache+
Duo Plus*

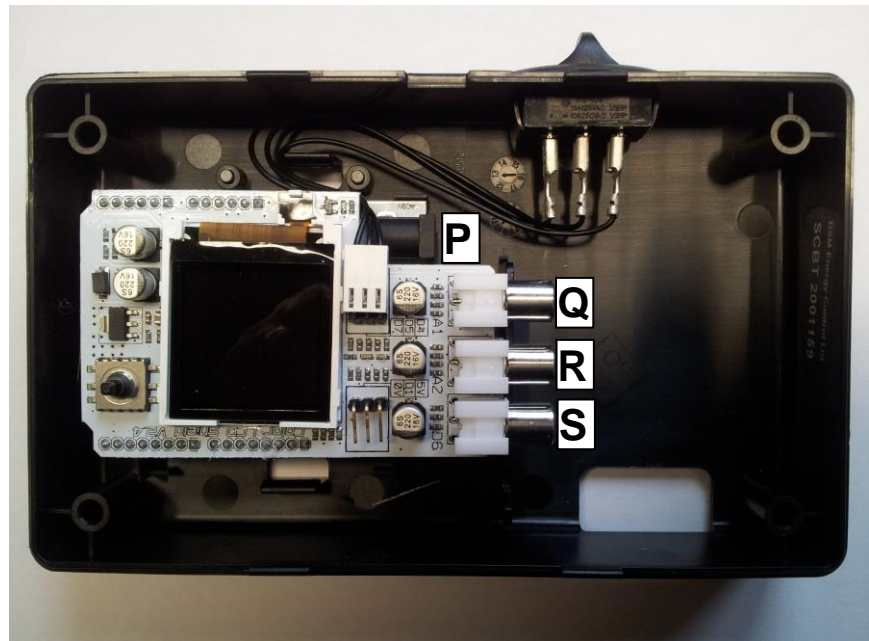

*SolarCache+
Wi-Link*

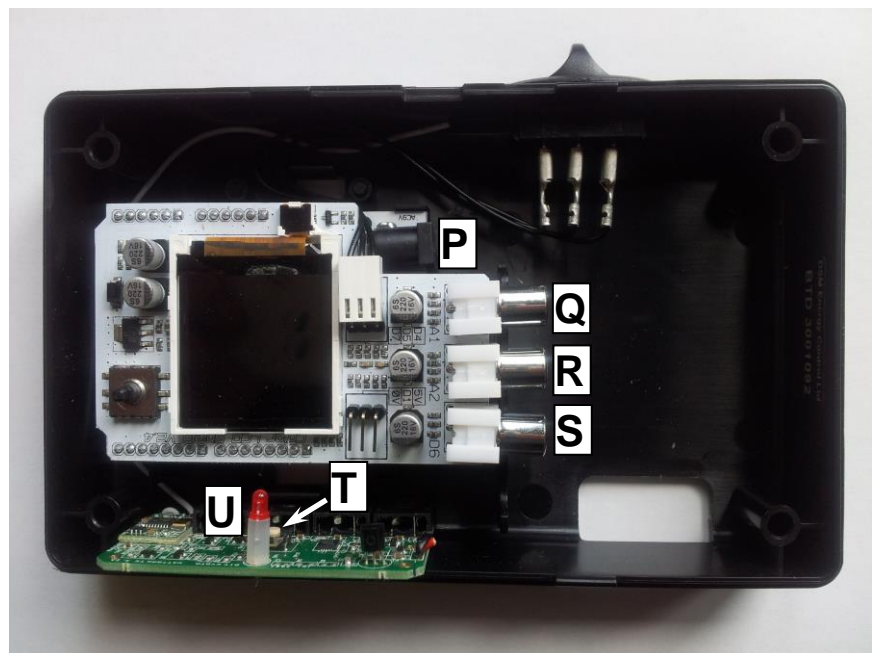

P: controller low-voltage AC power supply input from the power throttle (*Mono & Duo Plus*), or from the AC power supply (*Wi-Link*)

Q: socket for the clip-on transformer which monitors the current at the electricity meter

R: socket for the clip-on current transformer which monitors the PV output (not used in the *Mono* version)

S: low-voltage control signal output to the power throttle (not usually needed in the *Wi-Link* version)

T: wireless transmitter pairing button (*Wi-Link* version only)

U: transmitter signal LED (*Wi-Link* version only)

4 Wiring and connections

SolarCache+Mono and *SolarCache+Duo Plus*: insert the supply lead plug end into socket P and connect the free ends to the AC O/P screw terminals within the power throttle, as shown in Figures 2a and 3a. These may be connected either way around.

A length of 5-core 1.5mm cable is provided together with a PVC cable gland. Use this between the consumer unit and the power throttle, intercepting the dedicated water heater circuit. Make the connections as shown in the three wiring diagrams, Figures 2a, 3a and 4 for *SolarCache+Mono* and *SolarCache+Duo Plus*, and Figures 2b, 3b and 4 for *SolarCache+Wi-Link*. At this stage, **please leave the current transformer/s plugged in but unclipped**.



British standard BS 7671: 2008 (amended 2011), regulation 537.3.2.1, allows the circuit-breaker in the consumer unit to act as ‘the means of local isolation’ for switching off the *SolarCache+* unit and associated circuits for maintenance purposes provided that you mount the power throttle near by the consumer unit. However, if you are mounting the power throttle some way away from the circuit-breaker (for example, in another cupboard or in a room away from the consumer unit), you will need to provide a double-pole isolation switch next to the power throttle as ‘the means of local isolation’. Alternatively, you can install a means of locking off the circuit-breaker.

Figure 2a: control unit and power throttle wiring (*Mono & Duo Plus* versions)

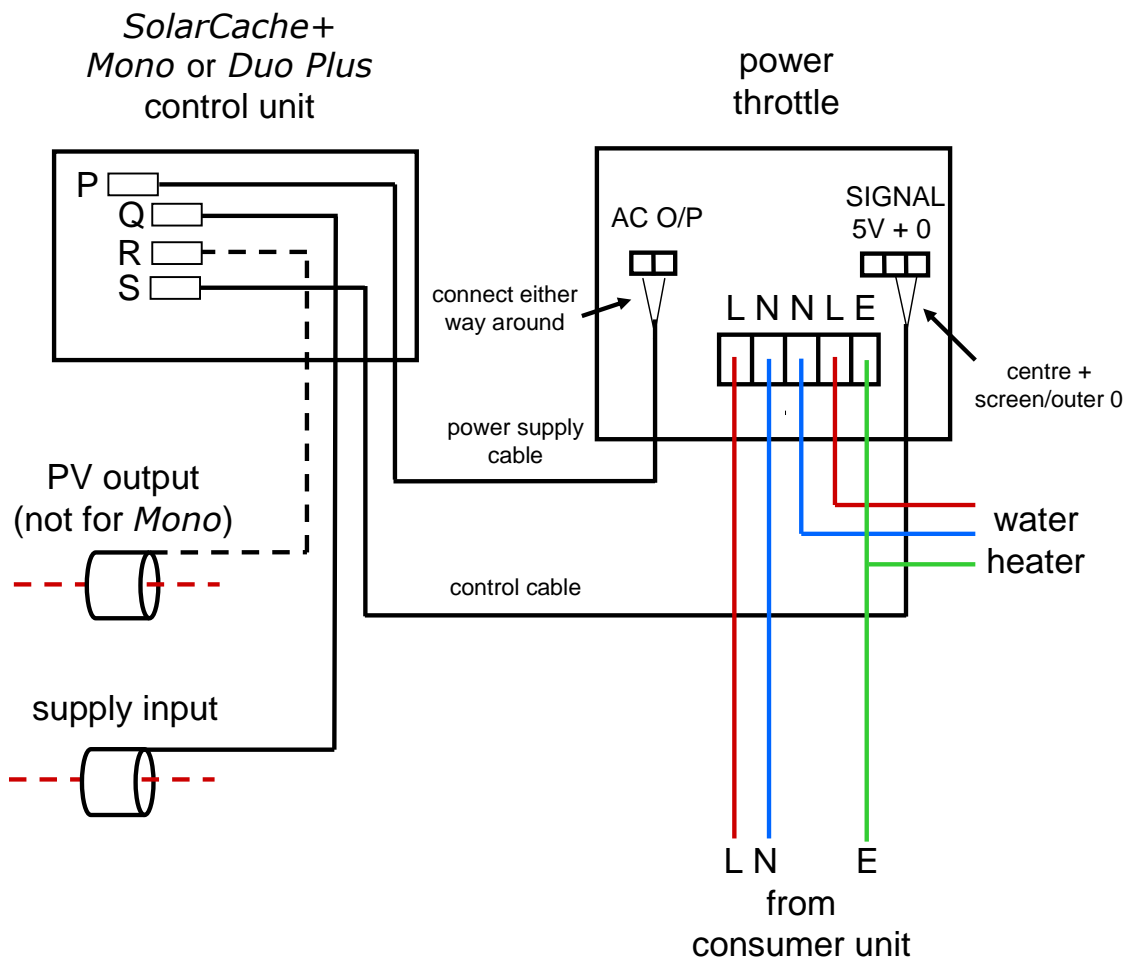

Figure 2b: control unit and power throttle wiring (**Wi-Link** version)

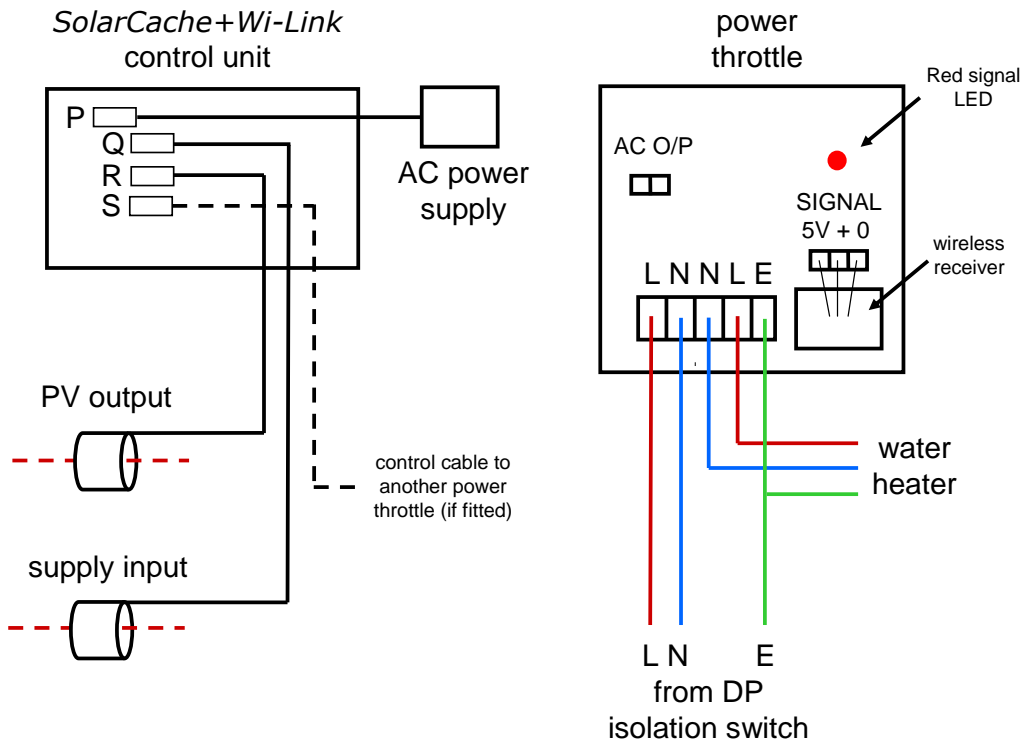

Figure 3a: connections in the power throttle (**Mono & Duo Plus** versions)

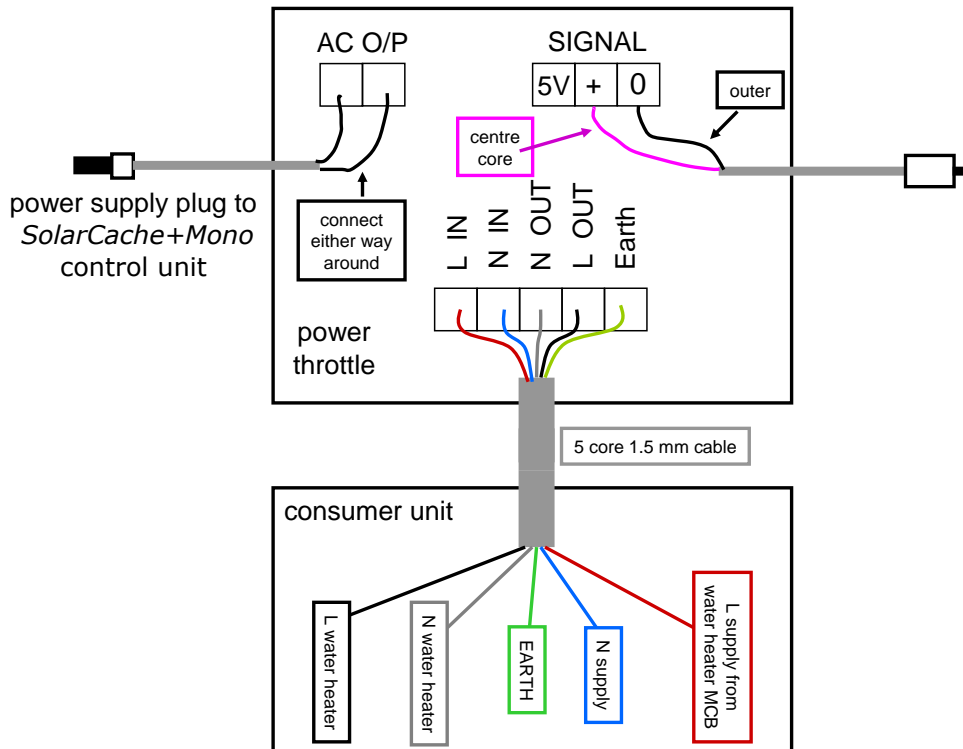

Figure 3b: connections in the power throttle (*Wi-Link* version)

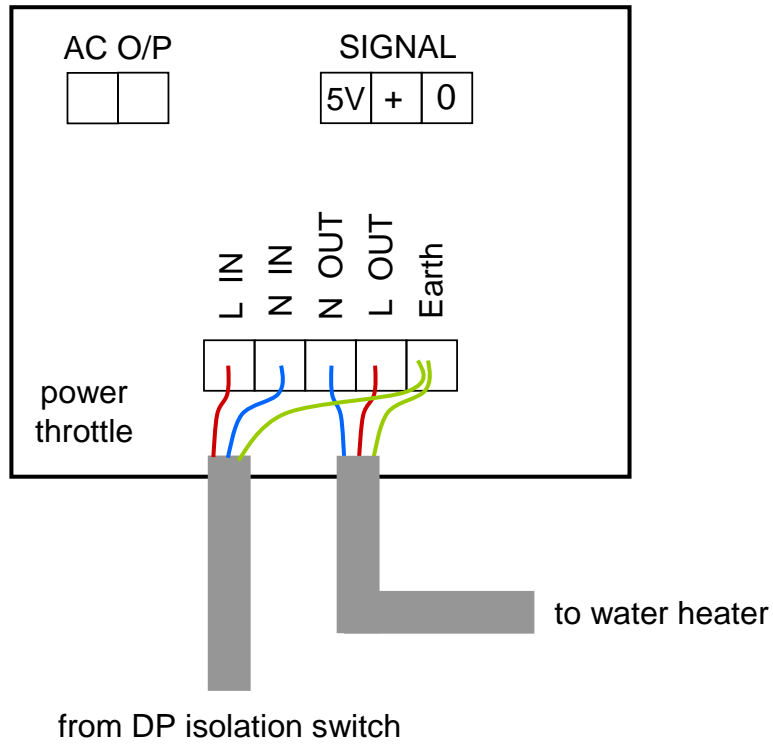
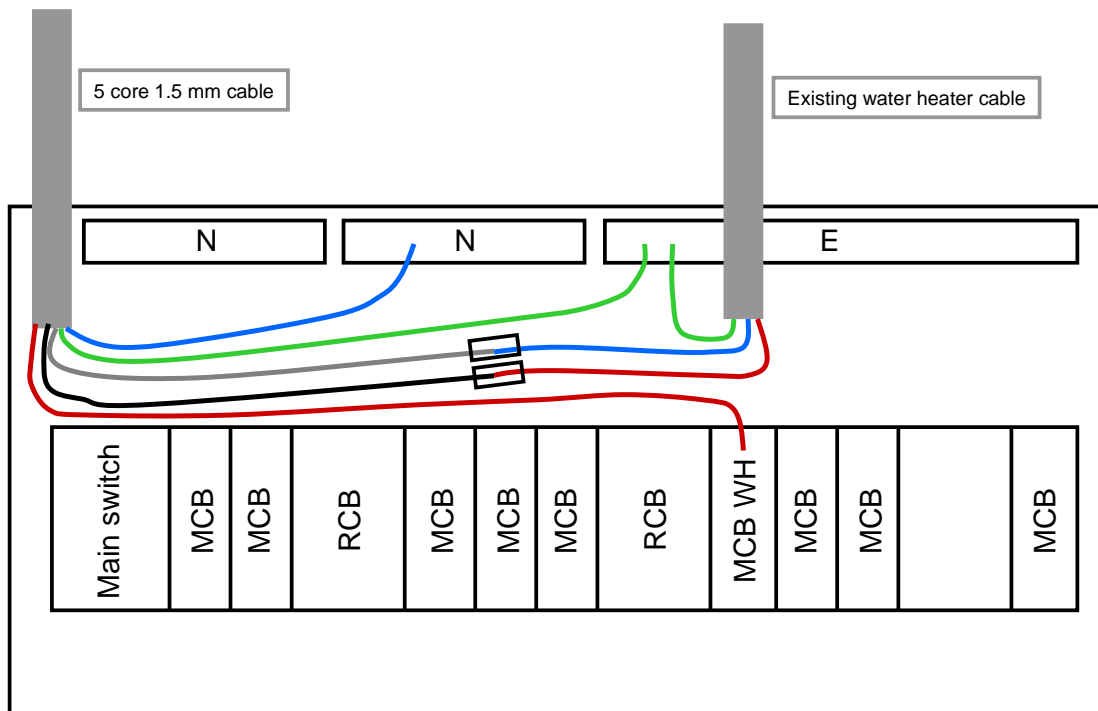

Figure 4: connections in the consumer unit



5 Commissioning

Check that all AC electrical connections are complete and ready for energizing. Carry out appropriate electrical tests of your wiring, according to BS7671:2008 (amended 2011). Switch on the immersion heater MCB in the consumer unit and the power throttle DP isolation switch (if fitted) to energize the system. If fitting the *Wi-Link* version, switch on the AC power supply.

Slide the slider function switch, located on the top of the *SolarCache+* controller unit to the mid position. The legend “Heat: automatic” should appear in green at the bottom of the display. If instead the legend “Heat: 1-hr boost” appears, slide the switch to the left, wait for the display to show “Heat: continuous”, and then slide it back to the centre. The legend should change to “Heat: automatic” after a few seconds.

Make sure that the PV system is switched on and generating power. If fitting the *Duo Plus* or *Wi-Link* versions, clip the PV current transformer around the PV supply live wire. (Please refer to Figure 5 for correct placement. Note that the connection block (labelled Block) is not always present.) Take care to ensure that the magnet surfaces are clean and engage properly. After a few seconds, the yellow ‘Sun’ display should indicate the value of the power currently being generated by the PV plant. If the display reads zero, or if you get a red warning message, the current transformer needs to be unclipped and reversed so that the live wire feeds through from the other direction. (Note that the ‘Sun:’ display alternates every 6 seconds with the ‘Gen:’ display. The yellow bar, however, always shows how much power is being generated.)

Clip the electricity supply input current transformer (see Figure 5) around the live wire of the incoming electricity supply cable, between the supply cut-out fuse and the electricity meter, or between the electricity meter and the consumer unit, ensuring that both magnet surfaces fully engage. If the PV system is generating more power than the house uses, the ‘Net’ display value will be green after a short time (allow up to a minute) indicating that power is being exported. If the house usage is greater than the generated power, then the ‘Net’ display value will be shown in red.

You must check that the electricity supply input current transformer is correctly installed by turning on a high power appliance, such as an electric kettle. The ‘Net’ display figure should increase and appear in red as power is being imported from the grid. If the opposite happens (i.e. the ‘Net’ display goes down, or turns green), then the current transformer requires reversing so that the live wire feeds through from the other direction.

Figure 5: current transformer placement

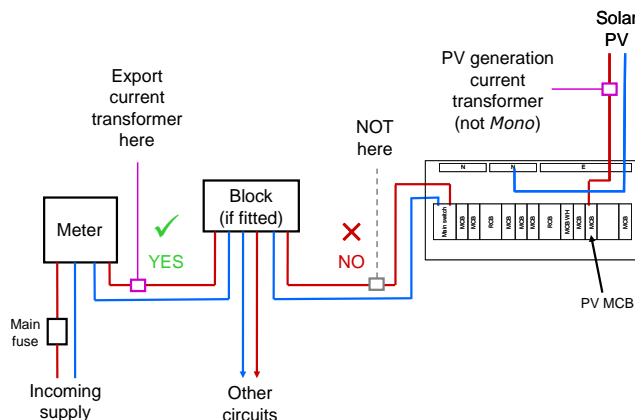

If you are fitting the Wi-Link version, check that the power throttle is receiving the signal from the control unit as follows. The red led inside the control unit (labelled U in Figure 1) should flash regularly once per second, with a double flash every six seconds. The signal LED inside the power throttle will flash approximately every 1.5 seconds, until it receives a message from the controller. Push to the slider switch on top of the control unit over to the left-hand position. The legend “Heat: continuous” should appear in red at the bottom of the display. Now look at the red signal LED in the power throttle noted on Figure 2b. This should be lit continuously. Slide the switch on the control unit back to the centre, wait for the display to show “Heat: 1-hr boost”, slide it back to the left, wait for “Heat: continuous”, and then slide it to the centre. The legend should change to “Heat: automatic” after a few seconds. Check the blue “Control:” bar on the display. The red signal LED in the power throttle should change brightness as the bar changes length, being fully lit when the bar is at its full length, and off when the bar is at zero length.

6 Three-position slider function switch

The three-position switch is located on the top right-hand side of the *SolarCache+* controller. It is a slide switch and operates as follows:

SolarCache+ Mono:

Left position: the heater is fully on, and *SolarCache+Mono* has no effect. The legend “Heat: continuous” appears in red at the bottom of the display, and the blue “Control:” bar should be at full length.

Mid position: the heater is controlled automatically by *SolarCache+Mono*. The legend “Heat: automatic” or “Heat: 1-hr boost” (see below) appears in green (or yellow) at the bottom of the display. This is the normal position.

Right position: the heater is turned off and *SolarCache+Mono* has no effect.

Mid-left-mid movement: if you move the switch from the mid position to the left position, wait for the words “Heat: continuous” to appear, and then slide it back to the mid position, the heater is turned fully on for 1 hour. This is useful for all-electric systems to boost the heat. Repeat the process to cancel this function. During the boost period, the legend “Heat: 1-hr boost” will appear in yellow at the bottom of the display, and the blue “Control:” bar should be at full length.

SolarCache+Duo Plus and *SolarCache+Wi-Link:*

Left position: the heater is fully on, and *SolarCache+* has no effect. The legend “Heat: continuous” appears in red at the bottom of the display, and the blue “Control:” bar should be at full length.

Mid position: the heater is controlled automatically by *SolarCache+*. The legend “Heat: automatic” or “Heat: 1-hr boost” (see below) appears in green (or yellow) at the bottom of the display. This is the normal position.

Right position: the heater is controlled automatically by *SolarCache+*. However, the heater is turned fully on during the boost periods under the control of the internal clock. You can set up to three boost periods (see below). This switch setting is intended for

SolarCache+

the PV energy use maximiser

Economy 7 (or similar reduced rate tariff) users. The legend “Heat: auto/night” appears in yellow at the bottom of the display. The current clock time is also displayed after the “Control:” legend. The legend changes to “Heat: boost 1”, “Heat: boost 2” or “Heat: boost 3” during the corresponding boost period, and the blue “Control:” bar should be at full length.

Mid-left-mid movement: if you move the switch from the mid position to the left position, wait for the words “Heat: continuous” to appear, and then slide it back to the mid position, the heater is turned fully on for 1 hour. This is useful for all-electric systems to boost the heat. Repeat the process to cancel this function. During the boost period, the legend “Heat: 1-hr boost” will appear in yellow at the bottom of the display, and the blue “Control:” bar should be at full length.

6 System parameter setting (clock, boost periods, heater power, and connectivity)

The toggle switch on the left-hand side of the display may be used to set the clock, up to three boost periods (not *Mono*), and the nominal rating of the heater in Watts. If using the *Wi-Link* version with an additional wired power throttle fitted, you can also specify which of the power throttles to connect, or both.

The toggle switch has five positions: press up (UP), press down (DN), press left (L), press right (R), and press in (IN). (These directions are appropriate for a unit mounted on a wall in the correct orientation.) When power is first applied to the unit, the legend labelled 1a (*Mono* version) or 1b (*Duo Plus* or *Wi-Link* version) appears shortly after the opening information screen. Normal operation resumes if you do nothing during the count-down period, otherwise, the legend changes to that shown at 1a.

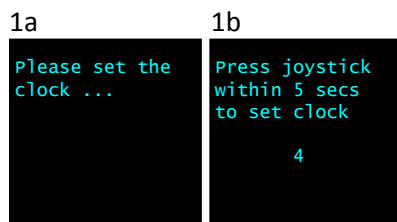

You can also get back to the first setting screen by pressing IN during normal operation when the screen is not being refreshed. (Press again if there is no response the first time.)

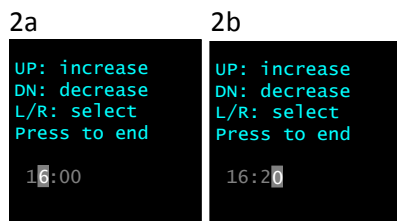

The first setting screen displays the legend shown at 2a with the current clock time in the 24-hour format HH:MM in dark gray. The right-hand digit of the hour's part of the time has a lighter gray background and the digit appears in white. This is the selected digit, and you can increase (press UP) or decrease (press DN) the value shown in the HH field in the range 00 to 23. For example, if the current time is twenty past four in the afternoon (16:20) you would set this to 16 as shown.

You can switch between the HH and MM fields by pressing L or R. The left-hand digit of the MM field will then be selected, and you can set the MM field in the range 00 to 59. You would set this to 20 (as shown at 2b).

When you are satisfied, press IN to start the clock at the time shown by the digits on the screen. The words **Clock set** appear briefly, and then the setting screen for setting the three boost periods (*Duo Plus* and *Wi-Link* versions only.) The setting screen for the first period of heat boost appears (shown at 3a). This is the time at which the heater is turned on (default value 02:00) during the first period of boosting. Set the digits to your requirement, and then press IN to set the turn-off time (3b).

Press in again when you have entered the time at which you want the first boost period to end.

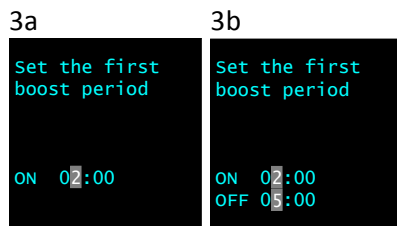

You can set the on and off times of the second and third heat boosting periods in a similar fashion. By default, these are set to 00:00 and 00:00 respectively. The controller will ignore a boost period altogether if the on and off times are the same. Make sure that the first, second and third boost periods **do not** overlap with each other! You should also note that a boost period must **not** include midnight, so ON at 23:00 and OFF at 01:00 will cause unexpected results!

Press IN after setting the off time of the third boost period to set the nominal heater power. This defaults to 3000 (i.e. a 3 KW immersion heater) shown at 4. The power field is a four-digit decimal number which may be set in the range 0000 to 9999. You may select any of the digits by pressing L or R. Press IN to exit the parameter setting pages (*Mono* or *Duo Plus* versions).

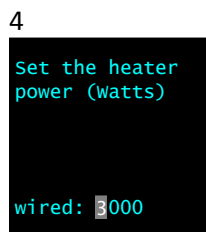

You can set two heater powers with the *Wi-Link* version, corresponding to the heater connected to the wireless power throttle (w'less) and the wired power throttle (if fitted). The displays are illustrated at 5a and 5b. You can also set which of the two, or both, is connected to the *SolarCache+* controller (illustrated at 5c). Press IN to complete the parameter setting.

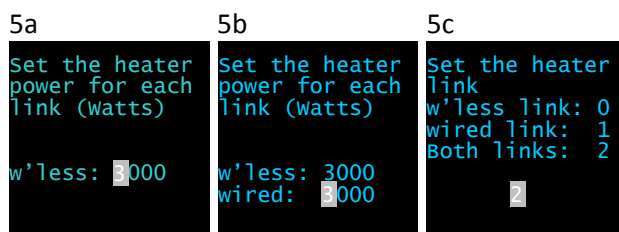

7 Handover

Please remember to give the householder the User Instructions, and show that the system is operating correctly. You will also need to demonstrate how it works, particularly the parameter setting pages and slider-switch control.

8 Technical specification and support

SolarCache+ is sold for professional use and installation. Please contact our technical support team at DSM Energy Control Ltd., if you have any questions regarding the installation or operation of the *SolarCache+* systems. The email address is support@solarcache.co.uk or you can call a telephone number given below.

Power consumption of controller (Watt)	2
Transfer efficiency of throttle	98
Max. load current surge (Amp)	half a cycle 250, non-repetitive /25
Max. load current constant (Amp)	17
Mains frequency tolerance at 50Hz (Hz)	+/- 1
Operating temperature (°C)	65 operational
Maximum power dissipation at 3kW output (Watt)	13
Internal fuse	20 A, 1 ¼" ceramic
Average packaged weight (kg)	3.5
Packaged dimensions (cm)	L:33 W:25 H:17
Controller dimensions (cm)	W:16.3 H:10 D:5
Power throttle dimensions (cm)	W:15.5 H:22.5 D:7.8

DSM Energy Control Ltd.
Company No. 08044291
The Old School,
High Street,
Horningsea,
Cambridge CB25 9JG
Telephone: 01223 440100 or technical 07979 953359
www.solarcache.co.uk

