

Front View (0.21 : 1)

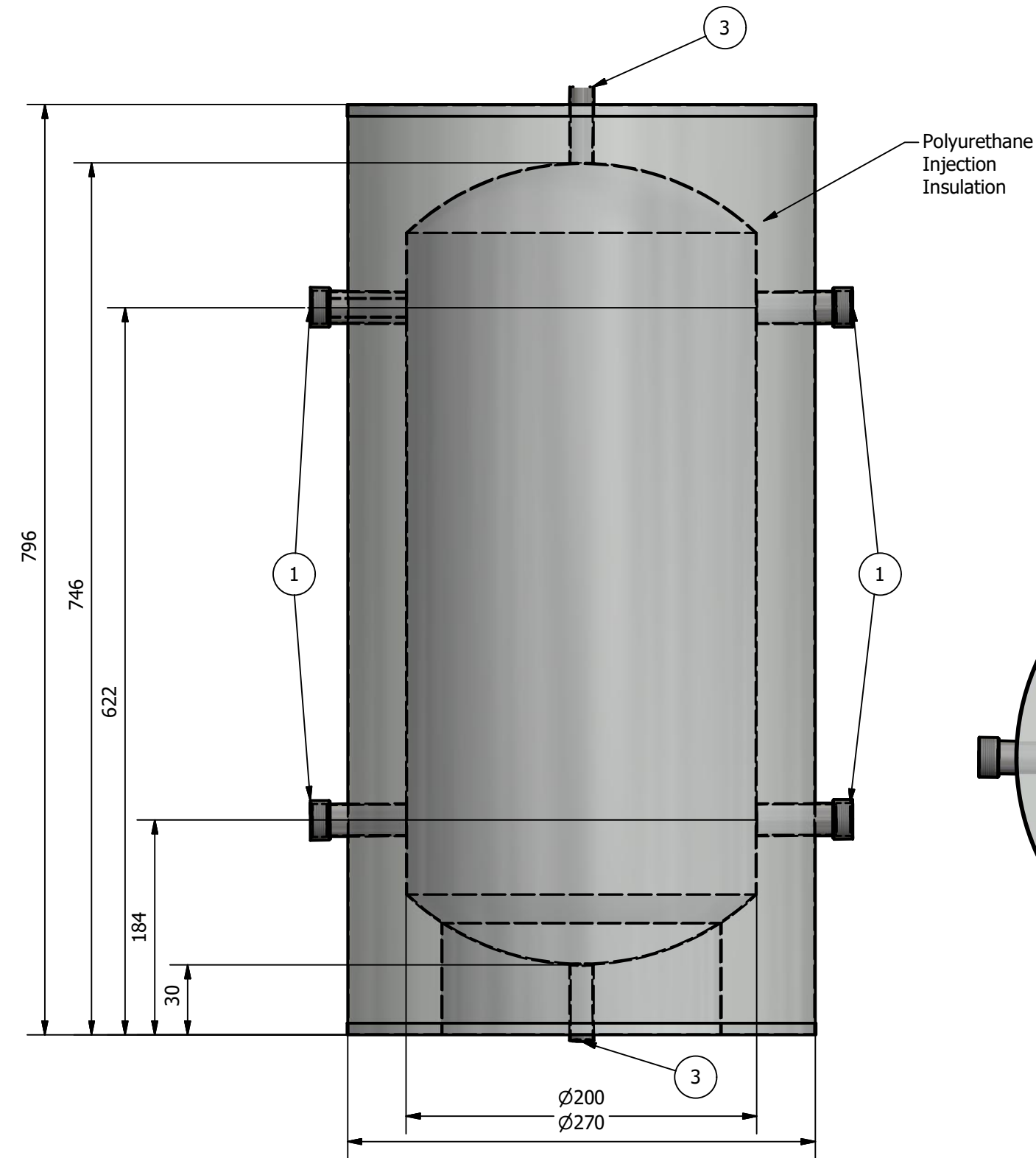

Top View (0.21 : 1)

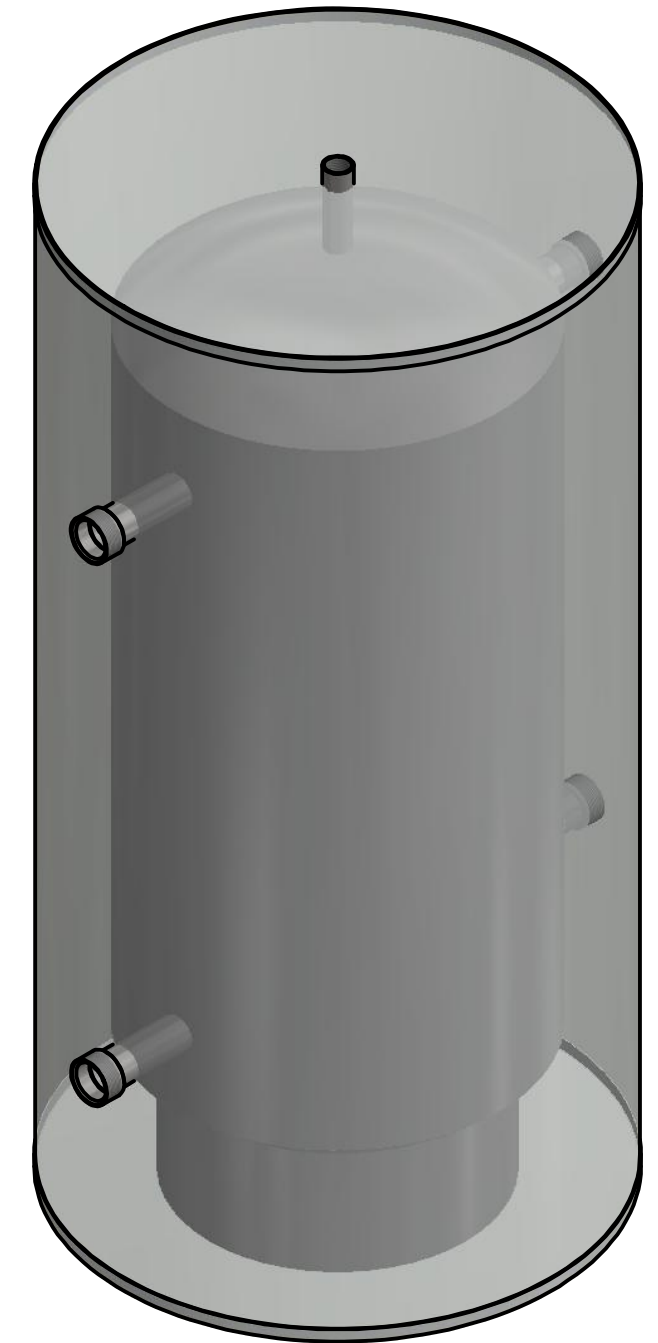
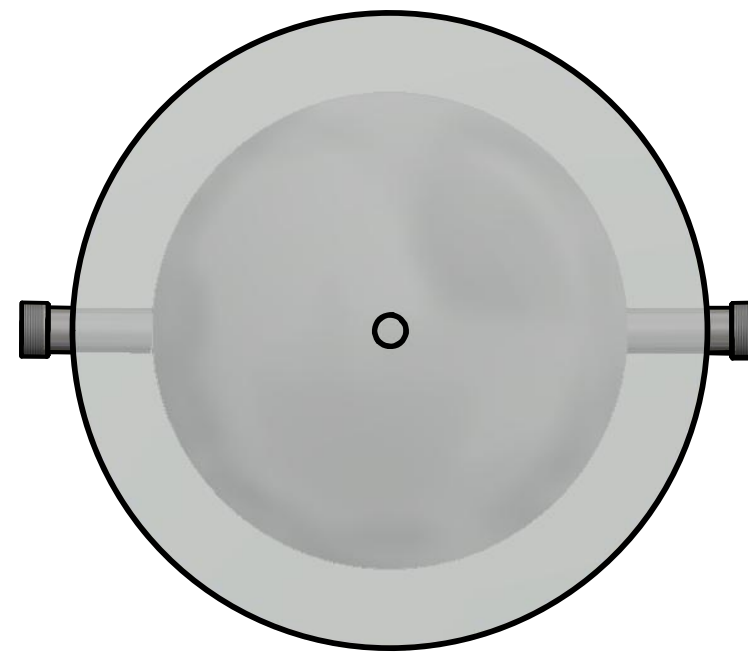

PARTS LIST		
ITEM	QTY	PART
1	4	28mm Compression Fitting (65mm Extended)
3	2	G 1/2 INT - 65 mm Extended (Stainless Steel)

	PRIMARY:	SECONDARY:	ADDITIONAL NOTES:
MAX WORKING PRESSURE:	N/A BarG	6 BarG	1. Stand Size = 750 x 28 x 1 mm
DESIGN PRESSURE:	N/A - N/A BarG	0 - 6.7 BarG	2. Approx Dry Weight = 15 kg
TEST PRESSURE:	N/A BarG	10.05 BarG	3.
DESIGN TEMPERATURE:	N/A - N/A °C	0 - 0 °C	4.
STANDING HEAT LOSS:	22 kWh/24h at 60°C & 21°C		5.

This drawing, and information contained within, is the property of World Heat Ltd. and must not be copied in whole/part or used for manufacture/otherwise disclosed without the prior written consent of the company.

TITLE:	SPEC25SSVolumiser		
DESCRIPTION:	25 Litre Inline Volumiser		
QUANTITY:	1	CASE:	None
CUSTOMER:	WH	WH REF.:	-
DESIGNED BY:	Mark Sidebottom	DATE:	08/09/2021
CHECKED BY:		DATE:	
APPROVED BY:		DATE:	
DRAWING NO.:	88761	REVISION:	1
Unit 4, Tudor Industrial Estate, Dukinfield, SK16 4RN. Tel: 0161 343 8610 Email: sales@worldheat.co.uk			