

SBB Trend

300 l.

UK

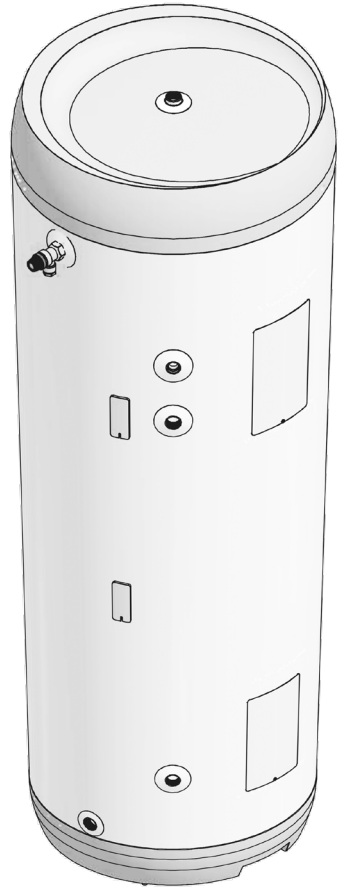

SAFETY INFORMATION
O&M INFORMATION
INSTALLATION MANUAL
TDS - TECHNICAL DATA SHEET

STIEBEL ELTRON

11010260-00 - 02-2023

CONTENTS

1. Safety instructions	3
1.1 General information	3
1.2 Safety instructions for users	4
1.3 Safety instructions for installers.....	4
2. Product description	5
2.1. Product identification	5
2.2. Intended use	5
2.3 CE marking	5
2.4 ErP product fiche (TDS).....	5
3. Installation instructions	6
3.1. Products covered by these instructions	6
3.2. Included in delivery	6
3.3. Product dimensions	6
3.4. Requirements for installation, location and positioning	6
3.5. Component check list	7
3.6. Supply requirements.....	7
3.7. General layout.....	8
3.8. Pipe installation	9
3.9. Positioning the unit.....	9
3.10 Flow and Return and Motorised valve...10	
3.11 Commissioning	11
3.12 Draining	11
3.13 System flushing.....	11
3.14 Piping Diagrams.....	12
4. Electrical installation	13
4.1. Wiring and electrical fitting.....	13
4.2. Immersion heater thermostat.....	14
4.3. Indirect heating system.....	14
4.4 External heat source.....	15
4.5 S-plan wiring.....	16
4.6 Y-plan wiring.....	18
4.7 Handover to end-user.....	20
5. User Guide	21
5.1. Settings.....	21
6. Safety and servicing	22
6.1. Safety Cut-out	22
6.2 Intermittent or slow discharge from tundish	22
6.3 Continuous very hot water discharge from tundish.....	22
6.4 Expansion vessel maintenance	22
6.5 Guarantee	22
6.6 Servicing Procedure	22
7. Fault Finding Guide	23
7.1. Faults and fixes.....	23
7.2. Alternative discharge	24
7.3 Secondary return	25
7.4 Spare parts.....	25
8. Technical data	26
8.1. Data table	26
Installation, commissioning and Service Record Log Book	27
Guarantee	30

1. SAFETY INSTRUCTIONS

1.1 General information

- Read the following safety instructions carefully before installing, maintaining or adjusting the water heater.
- Personal injury or material damage may result if the product is not installed or used in the intended manner.
- Keep this manual and other relevant documents where they are accessible for future reference.
- The manufacturer assumes compliance (by the end-user) with the safety, operating and maintenance instructions supplied and (by the installer) with the fitting manual and relevant standards and regulations in effect at the date of installation.

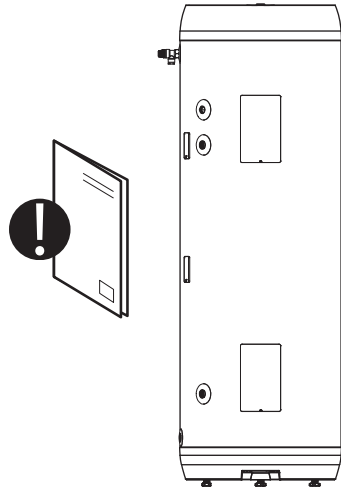

Symbols used in this manual:

	WARNING	Could cause serious injury or death
	CAUTION	Could cause minor or moderate injury or damage to property
	DO NOT	
	DO	

1.1.2 Acknowledgement of purchase

Thank-you for purchasing the SBB 300 Trend unvented hot water cylinder.

The product is an unvented hot water cylinder for use with heat pump installations. Its energy efficiency as defined by standing heat losses is the best in its class due to the use of vacuum insulated Panels (VIP) and will save the householder significant energy costs over the lifetime of the cylinder.

This manual gives detailed advice for installation and should be read carefully prior to fitting any unvented unit. SBB cylinders are not suitable for gravity fed primary systems. In known hard water regions, precautions should be taken to prevent limescale formation in hot water cylinders, in accordance with Building Regulation Part L, Domestic Heating Compliance Guide.

This cylinder must be installed by a competent person and be installed in compliance with the Installation and Maintenance Instructions, all current legislation, codes of practice and regulations governing the installation of unvented hot water cylinders in force at the date of installation.

NOTE

Please read this manual before installation and leave with the cylinder. The manual and attached logbook serve as the cylinder guarantee.

1.2 Safety instructions for users

⚠ WARNING

⊘	Safety valve overflows shall NOT be sealed or plugged (safety valve not included).
⊘	The product shall NOT be covered over the cover on the front.
⊘	The product shall NOT be modified or changed from its original state.
⊘	Children shall NOT play with the product or go near it without supervision.
❗	The product shall be filled with water before the power is switched on.
❗	Maintenance/settings shall only be carried out by persons over 18 years of age, with sufficient understanding

⚠ CAUTION

⊘	The product must not be exposed to frost, over-pressure, over-voltage or chlorine treatment. See warranty provisions.
⊘	Maintenance/settings shall not be carried out by persons of diminished physical or mental capacity, unless they have been instructed in the correct use by someone responsible for their safety.

1.3 Safety instructions for installers

⚠ WARNING

⊘	Safety valve overflows must NOT be sealed or plugged (safety valve not included)
❗	The discharge pipe from any safety device shall be at least one pipe size larger than the nominal outlet size of the safety device (< 9m length). The discharge pipe shall have continuous fall to drain, be uninterruptible and frost-free at all times.
❗	Fixed electric fittings shall be used for installation in new homes or when changing an existing electrical setup in accordance with regulations. A mains cable with plug for wall socket can be used when replacing the product without changing the electrical setup.
❗	The mains cable shall withstand 90°C. A strain reliever must be fitted.
❗	The product should be filled with water before the power is switched on.
❗	The relevant regulations and standards, and this installation manual, must be followed.

⚠ CAUTION

❗	The product shall be placed in a room with a floor drain. The manufacturer assumes no responsibility whatsoever if this provision is not followed.
❗	The product shall be properly aligned vertically and horizontally, on a floor or wall suitable for the total weight of the product when in operation. See type plate.
❗	The product must have a clearance for servicing of 40 cm in front of the electric junction box cover / 10 cm over the highest point.

2. PRODUCT DESCRIPTION

2.1 Product identification

Identification details for your product can be found on the type plate fixed to the product. The type plate contains details of the product in accordance with EN 12897:2016 and EN 60335-2-21, as well as other useful data. Contact Stiebel Eltron for more information.

SBB Trend products are designed and manufactured in accordance with:

- Pressure vessel standard EN 12897:2016
- Safety standard EN 60335-2-21
- Welding standard EN ISO 3834-2

The manufacturer is certified for

- Quality ISO 9001
- Environment ISO 14001
- Work environment ISO 45001

2.2 Intended use

The SBB 300 Trend is designed to supply homes with hot running water. The product is intended for use with alternative energy sources, specifically Stiebel Eltron heat pumps.

2.3 UKCA marking

**UK
CA**

The UKCA mark shows that the product complies with the relevant Directives.

The product complies with Directives for:

- Low voltage LVD 2014/35/EU
- Electromagnetic compatibility EMC 2014/30/EU
- Pressurised equipment PED 2014/68/EU

Any safety valve(s) used should be CE-marked and comply with the PED 2014/68/EU.

2.4 ErP product fiche - Technical Data Sheet

Trade mark	M T item No.	Model / identifier	ErP Rating	Standing heat loss W	Capacity L
Stiebel Eltron	206187	SBB 300 Trend - 2.8kW / 1x230V + HX 3.1m ²	B	69	284
Regulation: 2017/1369/EU - Regulation: EU 812/2013		Directive: 2009/125/EC - Regulation: EU 814/2013			
Heat loss tested according to standard: EN 12897					

3. INSTALLATION INSTRUCTIONS

3.1 Products covered by these instructions

206187 - SBB 300 Trend

3.1.1 Health and safety regulations

Handling Operations Regulations 1992 defines manual handling as: "any transporting or supporting of a load (including the lifting, putting down, pushing, pulling, carrying or moving thereof) by hand or bodily force" The Regulations set no specific requirements such as weight limits. However common sense still has to be used based on an ergonomic approach for each individual.

The product shall be transported and stored in a vertical position.

3.3.2 Delivery

The product shall be transported carefully as shown, with packaging. Use the handles in the box.





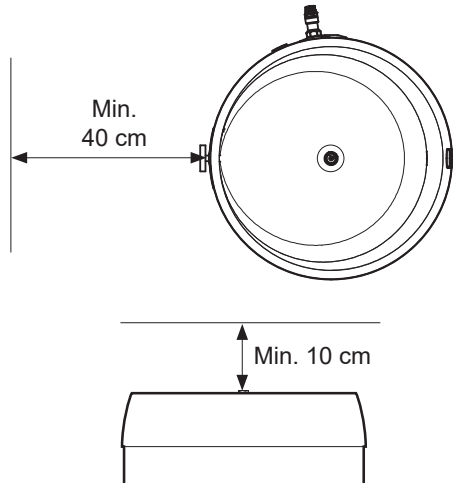
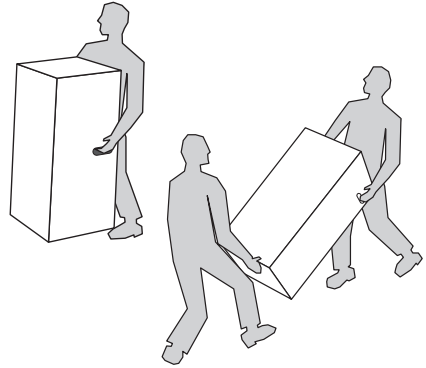

3.3.3 Siting the product

There are few restrictions on the siting of the product, however it should not be sited anywhere open to frost attack. The unit shall be placed on a stable flat surface capable of withstanding the weight of the cylinder when full (see data plate) and access must be allowed for maintenance purposes. Provision should also be allowed for the routing of the discharge pipe away from the cylinder to an outside point according to building regulation G3.

 CAUTION
Pipe stubs, valves etc. should not be used to lift the product as this could cause malfunctions.



3.4 Requirements for installation, location and positioning

 CAUTION	
	The product shall be placed in a room with a floor drain. The manufacturer assumes no responsibility whatsoever if this provision is not followed.
	The product shall be placed in a dry and permanently frost-free position.
	The product shall be placed on a floor or wall suitable for the total weight of the product when in operation. See type plate.
	The product must have a clearance for servicing of 40 cm in front of the electric junction box cover / 10 cm over the highest point.
	The product shall be easily accessible in the home for servicing and maintenance.

3.5 Component check list

Components supplied with the unit in a separate accessory kit for site fitting:

- Multibloc valve, includes pressure reducing valve, line strainer, balanced cold water take off (for shower or bidet only), check and expansion valve.
- Tundish
- 3/4" x 22mm Elbow / Drain Cock
- Motorized valve
- Expansion vessel.

3.5.1 *Components factory fitted*

- Immersion heater(s)
- Thermostats / thermal cut-out
- Temperature and pressure relief valve.

3.5.2 *Documentation supplied*

- Installation manual & log book

3.6 Supply requirements

An uninterrupted 22 mm cold water mains supply is recommended, a minimum standing pressure of 2.5 bar and a flow rate of 20 litres per minute with a 1 bar dynamic pressure is recommended. The cylinder will operate at lower pressures and flow rates however the performance will be compromised. This unvented unit is designed for use with supply pressure up to 10 bar. For pressures over 10 bar an additional pressure reducing valve must be fitted in the supply pipe to the unit.

3.6.1 *Expansion vessels*

The vessel accommodates expanded water when the cylinder is heated and prevents the cylinder reaching its maximum working pressure.

3.6.2 *Compatible fittings and components*

All thermostatically controlled boilers are compatible with indirect cylinders.

3.6.3 *Non-compatible products.*

Solid fuel boilers, wood burning stoves and other non-thermostatically controlled heat sources must not be used with unvented cylinders.

3.7 General layout

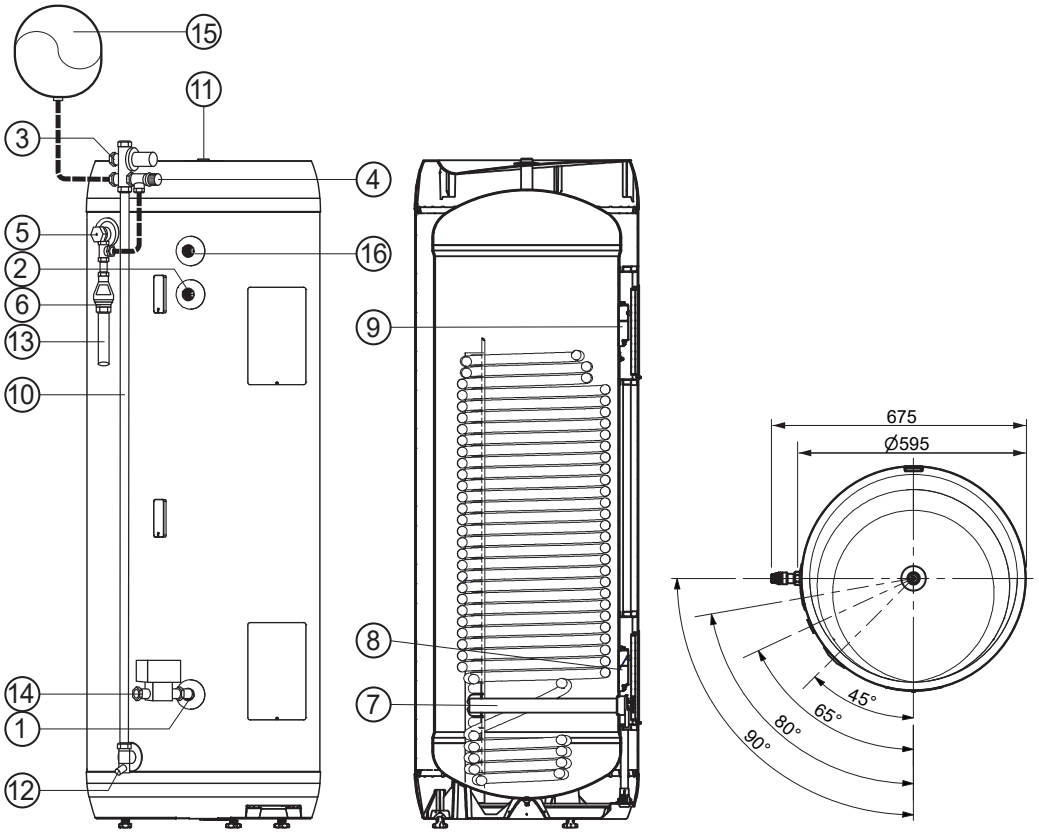

3.7.1 Reference chart

Ref no.	Key	Part No.
1	Flow 3/4" BSP	
2	Return 3/4" BSP	
3	Pressure Reducing Valve Multibloc (adjustable) includes Item 4	355030
4	Expansion relief valve (6 bar)	PREL355030
5	Temperature and Pressure Relief Valve	550853
6	Tundish	219005
7	Immersion Heater	71242
8	Immersion heater thermostat	80314
9	Thermostat	80345
10	Cold feed tube (not supplied, see pt. 3.7.2 Cold feed tube)	
11	Hot Water Outlet 3/4" BSP	
12	Elbow/Drain Cock	250445
13	Discharge Pipe (not supplied)	
14	Motorized valve (not factory fitted)	92000
15	Expansion vessel	
16	Secondary Return	

3.7.2 Cold feed tube

Vessel size	Length of tube (ø28) mm	Expansion vessel pre charge / size
300	1450	3 bar / 24 litre

3.8 Pipe installation

The product is designed to be permanently connected to the mains water supply. Approved pipes of the correct size should be used for installation. The relevant standards and regulations must be followed.

3.8.1 Incoming water pressure

The efficiency of the product depends on the incoming cold water pressure. The water pressure should be min. 2 bar and max. 6 bar throughout the day. Excessive water pressure can be adjusted by installing a pressure reduction valve.

3.8.2 Connecting pipes

Pipes of suitable size and quality should be run to the connections on the product and fixed with a suitable sealant.

A safety valve of the approved type (see page 3) should be fitted in the heating circuit (not supplied). The safety valve should not be plugged or blocked. Any overflow pipe from the safety valve must be uninterruptable, undamaged and frost-free with a fall to the drain.

3.9 Positioning the unit

The water heater should be fitted level on a hard surface with sufficient load strength to take the full weight of the cylinder (see technical data table page 12). There are no limitations regarding the fitting distance from walls etc., but it is strongly recommended to ensure easy access to all pipe fittings etc. The Temperature and Pressure relief valve and immersion heater are positioned at 90° apart. The product must be positioned to ensure that the tundish is visible and there is easy access to the thermostat and to remove the immersion heater if required.

3.9.1 Protection from frost

If the water heater is in danger of being exposed to frost while not operating under electric power, the unit must be drained to avoid damage. Make sure the electric power is turned off before draining, otherwise the heating elements can be damaged and the warranty is void. Draining instructions, see "Draining" on page 5.

3.9.2 Cold water supply

1. To obtain the best performance from your unvented system it is advisable to feed the

unit with an uninterrupted supply.

2. Before connecting to the multibloc, flush the cold supply pipework of all flux and debris.
3. Locate the water heater in a suitable position to facilitate the installation of the cold water supply, discharge fittings and pipework. Also take into account access to the immersion heater.
4. Fit the combined male elbow drain cock to cold supply point (14), so that the compression fitting is vertical.
5. Fit the length of copper tube 22 mm specified in Table 1 to the cold feed elbow (see pt. 4 above).
6. Fit the Multibloc (5) to the top of the copper tube (see pt. 5 above).
7. Connect 15 mm copper tube from the expansion relief valve (4) and also from the T&P valve (5) and join together in a Tee as shown on page 8.
8. Fit the tundish (8) to the bottom connection of this tee.
9. Connect the cold supply to the multibloc (5).
10. Fit the expansion vessel to the wall close to the water heater using the enclosed mounting bracket. Connect the expansion vessel to the multibloc, as shown on page 8.

3.9.3 Hot water supply

Connect the hot water supply pipe to the outlet (13). Ensure connection is water tight.

3.9.4 Balanced cold water supply (optional)

If no balanced cold supply is required, tighten the supplied blanking cap. If a balanced mains pressure cold water supply is required to a shower or bidet (over rim type only, ascending spray type requires type AA,AB or AD air gap), remove blanking cap and connect to the shower or bidet cold supply on the multibloc valve (5). (Major shower manufacturers advise fitting a mini expansion vessel in the balanced cold supply pipework to accommodate thermal expansion and prevent tightening of shower controls) Using the balanced cold connection to feed bath taps can reduce the flow available to the unvented cylinder.

3.9.5 Secondary return (optional)

Connect secondary return if required to fitting (18) page 8, see technical data table on page 26.

3.9.6 Discharge pipe

Connect the tundish outlet to the discharge pipe. Install the Tundish in a vertical position within a maximum of 600 mm from the Temperature and Pressure Relief Valve drain connection and away from electrical components. Ensure the expansion relief pipework discharges through the tundish. Tundish pipework must be 22 mm with a minimum vertical length of 300 mm below tundish. Maximum permitted length of 22 mm pipework is 9 m. Each bend or elbow is equivalent to 0.8 m of pipework. All pipework must have continuous fall and discharge in a safe, visible position. If any doubt, refer to Building Regulation G3. Discharge pipe must be dedicated to the cylinder and must not be used for any other purpose.

are 3/4" BSP female. The valve has 22mm x copper connections. The direction of primary flow in the coil is bottom to top. The maximum operating temperature of the primary flow would typically be 82°C.

For electrical connection of the motorized valve and immersion heater, please read Electrical Installation Instructions on page 13.

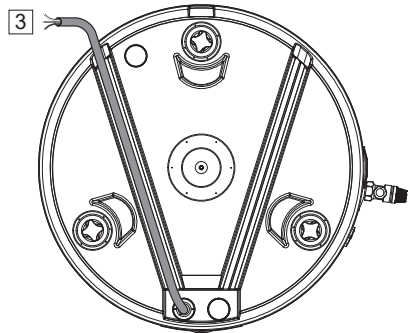

3.10 Flow and Return and Motorized valve

The boiler primary flow and return connections should be made connections 1 & 2. The motorized valve can be connected to either the primary flow or return pipe. The primary flow and return fittings

3.10.1 Fitting instructions

⚠ WARNING

❗	The product shall be filled with water before the power is switched on.
❗	The discharge pipe from any safety device shall be at least one pipe size larger than the nominal outlet size of the safety device (< 9m length). The discharge pipe shall have continuous fall to drain, be uninterruptible and frost-free at all times.

⚠ CAUTION

❗	The product shall be placed in a room with a floor drain. The manufacturer assumes no responsibility whatsoever if this provision is not followed.
❗	The product shall be properly aligned vertically and horizontally, on a floor or wall suitable for the total weight of the product when in operation. See type plate.
❗	The product must have a clearance for servicing of 40 cm in front of the electric junction box cover / 10 cm over the highest point.

3.10.2 Fitting recommendation

RECOMMENDATION

-	Allow clearance to the floor. Unscrew the feet a minimum of 15 mm from the bottom of the product.
-	Mains power cable (3) should be hidden under one of the channels in the bottom of the product.
-	If a non-return valve is fitted in the system a reduction valve and expansion vessel shall be fitted (to stop dripping from the safety valve).
-	If the maximum water pressure exceeds 6 bar in a 24-hour period, a reduction valve and expansion vessel shall be fitted.
-	For installation in a rooms which does not conform to the wetroom standard, a watertight drip tray with overflow pipe \geq 18 mm. inside diameter should be fitted under the product, in addition to an automatic stop cock with sensor. This will prevent possible material damage.

3.10.3 Pressure drop table - coil

Product info:		Pressure drop (mbar) at volume flow:							Cw value (m ³ /h):
Product	Coil surface m ²	540 L/h (0,15L/s)	900 L/h (0,25 L/s)	1800 L/h (0,50 L/s)	2700 L/h (0,75 L/s)	3600 L/h (1,00L/s)	4500 L/h (1,25 L/s)	5400 L/h (1,50 L/s)	Flow @ 1bar pressure drop
SBB 300 Trend	3.1	51	117	440	890	1555	2330	3340	2.9

3.11 Commissioning

1. Check all connections for tightness.
2. Open a hot water tap furthest away from the cylinder. Open the mains stop cock to fill the water heater. When water flows evenly from tap, allow to run for a few minutes to flush through any dirt, swarf or residue, then close the tap. Open successive hot taps to purge any remaining air.
3. Check all water connections for leaks and rectify if necessary
4. Manually operate Expansion relief valve 6 (see page 8) to ensure free water flow through discharge pipe by turning knob counter-clockwise. To close continue to turn counter-clockwise until the valve shuts.
5. Manually operate Temperature and Pressure Relief Valve 7 (see page 8) to ensure free water flow through discharge pipe (Turn knob counter-clockwise).
6. Switch electrical power on.

3.12 Draining

Switch off the electrical power (Important to avoid damage to element).

Isolate boiler from cylinder. Turn off the cold water supply valve. Open hot water tap. Open drain valve (see page 8) at base of cylinder. The unit will drain.

Draining process may be speeded up by opening the temperature and pressure relief valve. An internal ø18 mm hose can be applied to lead the water to a gully, sink or similar.

3.13 System flushing

This will not be necessary under normal circumstances as the line strainer will prevent ingress of foreign materials, however if flushing is required, run at least 50 litres of water from the cylinder at the highest possible flow rate. Close the taps and follow draining procedure (above).

3.14 Piping Diagrams

3.14.1 S-plan piping diagram

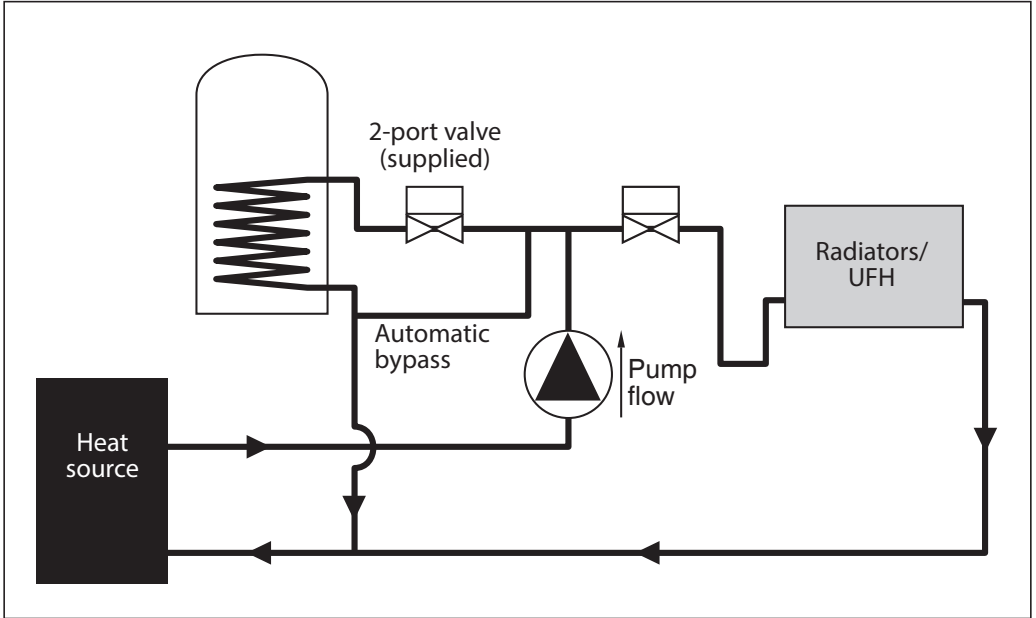

3.14.2 Y-plan piping diagram

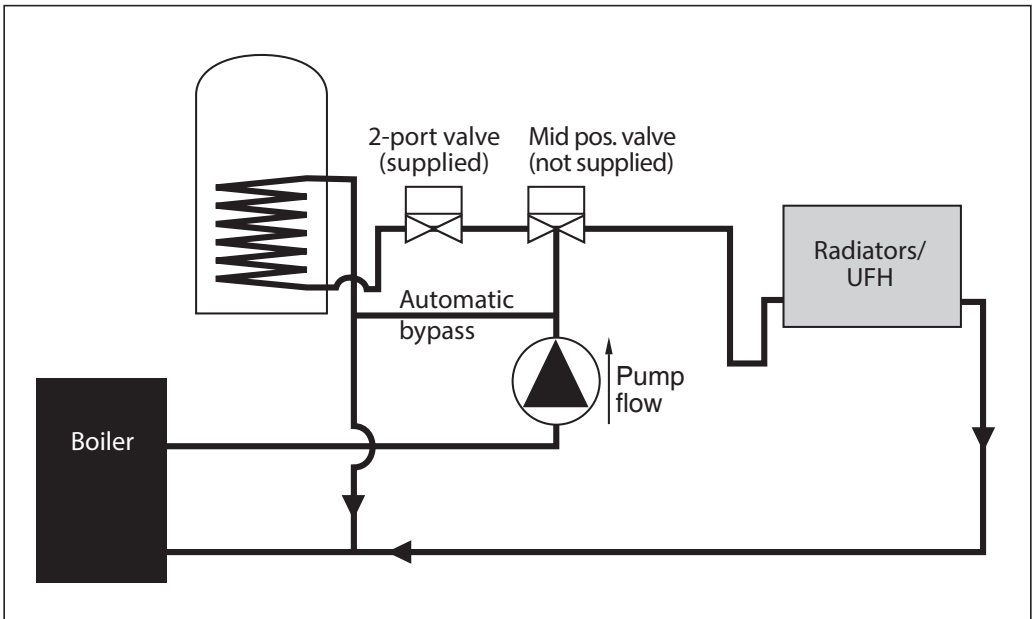

4. ELECTRICAL INSTALLATION

4.1 Wiring and electric fitting

All wiring must conform to current IEE regulations. Any fixed electric fittings must be installed by an authorised electrician. The relevant standards and regulations must be followed.

When connecting cables to thermostats, use spade connectors as shown in diagram. Ensure that connector is less than 10 mm in outer dimension and fits inside the shoulders of the thermostat and is not tightened onto the top of the shoulders.

3.6.1 Electrical components

Component	Note
Safety thermostat	85°C safety cut-off
Working thermostat	50-75°C adjustable
Heating element	2.8 kW - 1-phase 230V
Power supply cable	Heat resistant to 90°C
Internal wires	Heat resistant

3.6.2 Electrical connections in the junction box

⚠ WARNING

Constant voltage present at terminals L and N. Before any electrical work is done, the power supply must be disconnected and secured against activation while the work is in progress.

- A) Live wire (L) connected to point '1' on the thermostat.
- B) Neutral wire (N) connected to point '2' on the thermostat.
- C) Yellow wire with green stripe (⊕) – Earth – connected to the terminal for the heating element (hexagonal brass)

3.6.3 Torque settings

Component	Torque
G 1.1/4" external - heating element	60 Nm (+/- 5)
Thermostat screws (1 and 2)	2 Nm (+/- 0.1)
Earth screw on the element head	2 Nm (+/- 0.1)

⚠ WARNING

The thermostat must never be dismantled/opened. This will compromise its function and cause risk of overheating. Warranty will cease.

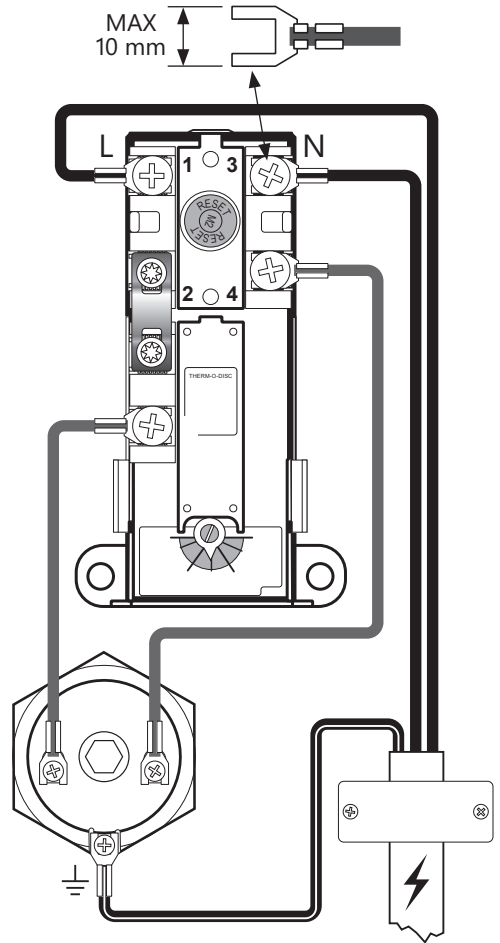

Electric connection, schematic

4.2 Immersion heater thermostat

The immersion heater is designed as an auxiliary heater as an emergency back-up. Power to immersion heaters should not be switched on until the unit is filled with water. All units are fitted with one 2.8 kW immersion heater which is located behind the electrical box. Alternative thermostats should not be used, regulations require immersion heaters on unvented cylinders to be connected with a thermal cut-out. Follow the wiring instructions connecting the live, neutral and earth as indicated.

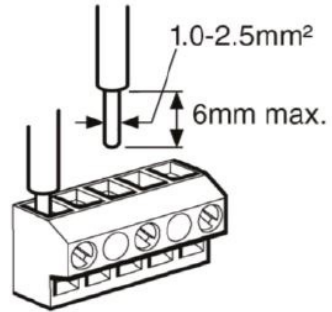

The unit must be connected to a minimum 16 amp dedicated permanent supply complying with current I.E.E Wiring regulations, isolation is required via a minimum 20 amp double pole isolation switch with a minimum 3 mm separation required. All electrical wiring should be carried out by a competent electrician, using a heat resistant cable (minimum 85°C), and be in accordance with the latest I.E.E Wiring Regulations.

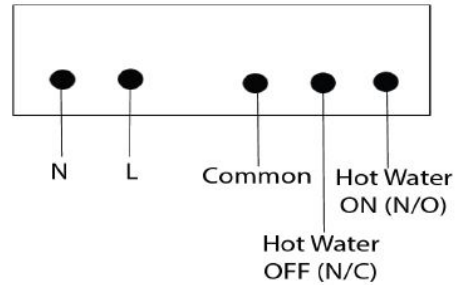

Each immersion heater has a working thermostat adjustable between 40°C - 70°C (+/- 5°C). A safety cut-out is also incorporated within the thermostat and will operate at 85°C (\pm 7°C). Should this happen, check reasons for thermal cut-out button being released and when satisfied press the reset button.

The immersion wiring should be run through a channel from base of cylinder to the immersion housing. The cable should be secured using the supplied clamps in the bottom opening of the channel.

4.3 Indirect heating system

4.3.1 Motorised valve

To comply with regulations governing the installation of indirect unvented cylinders, a motorised valve must be fitted in the primary pipework. Your cylinder has been supplied with a two port motorised valve, which will act as a positive energy cut-out should the safety cut-out operate. The motorised valve will also control the temperature of the domestic stored water via the cylinder thermostat, which is located in the electrical box. The unit can be installed on an "S" or "Y" plan system. Please follow the wiring instructions carefully.

The second (limit) safety thermostat is pre-set to 85°C with a concealed manual reset, to comply with building regulations. Should the safety cut out be brought into operation, the motorised valve will operate and close down the primary flow to the cylinder. To reset the safety cut-out and the motorised valve the reset button must be pressed in.

Also see S-Plan and Y-Plan Wiring on page 16-19. This product requires a fused permanent Live and Neutral supply.

4.4 External heat source

Heat sources to unvented hot water cylinders must be controlled by a thermal cut-out as well as a thermostat. The product is supplied with two sensor pockets (see pt. 4.6.4). Any external heat source controller (not supplied) shall be wired through the thermal cut-out.

Connect the external heat source to the coil with the primary flow in a bottom to top direction as shown in illustration.

If using a 6-wire 28mm or 1" BSP V4043H on either circuit the white wire is not needed and must be made electrically safe.

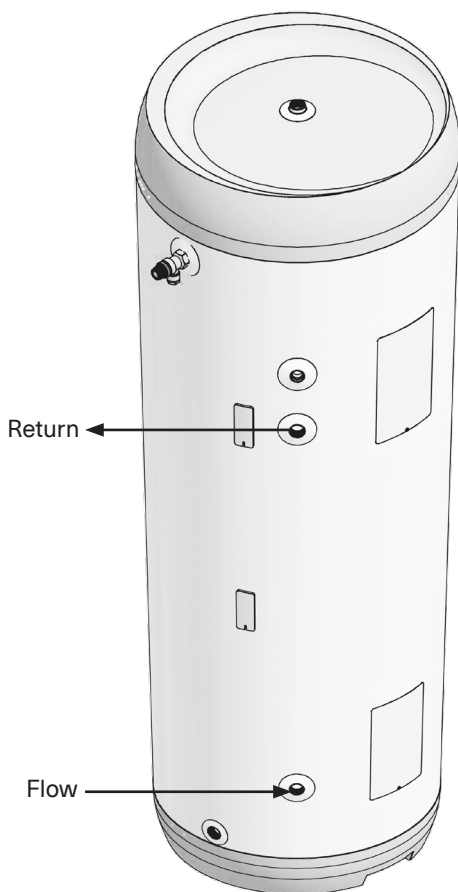

4.5 S-plan wiring

WARNING

The Manufacturer can not be held responsible if alternative wiring plans are used.

Important: Before resetting the safety cut-out or altering the thermostat setting isolate electrical supply to the unit before removal of the lid. Ensure the lid to the junction box is refitted before power is switched back on.

The SBB 300 Trend cylinder can be fitted with all types of boilers.

Standard boilers operate using room and cylinder thermostats. Please follow upper diagram: 'Wiring for Standard Boiler'.

4.5.1 Thermistor controlled boilers

Many popular boilers now use a thermistor principle. A thermistor temperature sensor is supplied with the boiler to attach to the cylinder. Temperature information is relayed back to the boiler control system.

Two sensor pockets (1) are provided to secure the sensor on the cylinder (see pt. 4.6.4).

The supplied motorised valve must be used in accordance with Building Regulation G3. This is wired from the supplied cylinder thermostat, wired as high limit stat. Please follow lower diagram: 'Wiring diagram for Thermistor Controlled Boiler'.

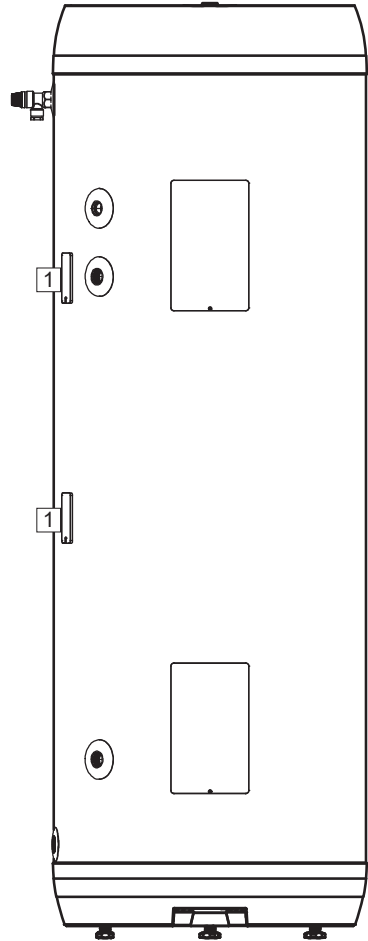

S-plan wiring

Wiring diagram for Standard Boiler

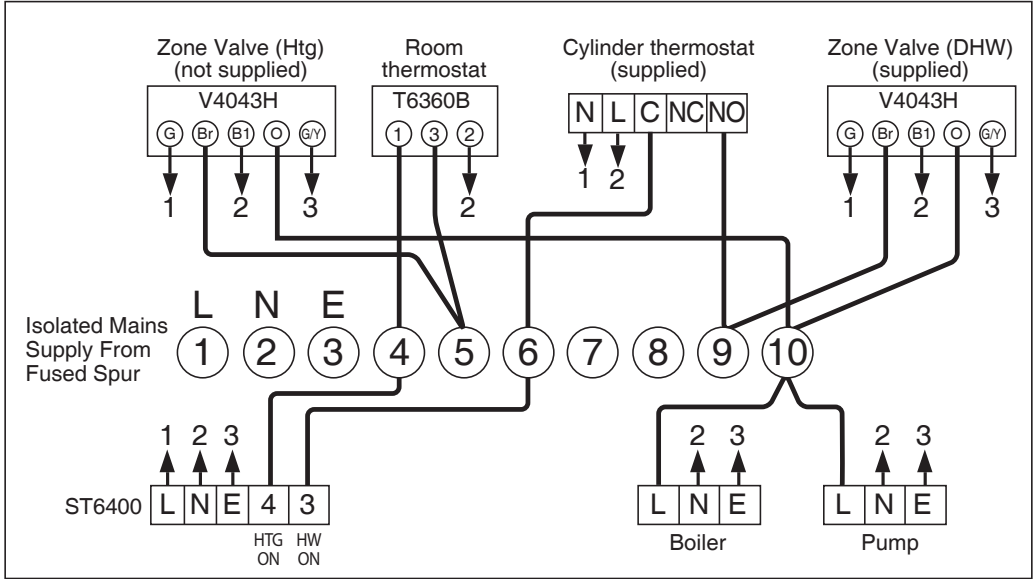

S-plan wiring

Wiring diagram for Thermistor controlled Boiler

Please contact boiler manufacturer for boiler specific wiring.

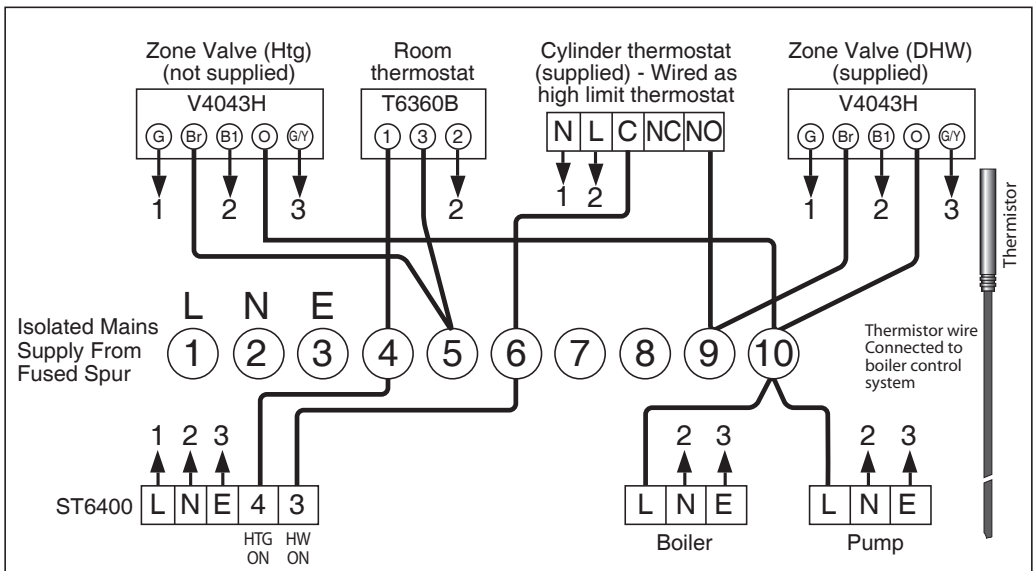

4.6 Y-plan wiring

WARNING

The Manufacturer can not be held responsible if alternative wiring plans are used.

Important: Before resetting the safety cut-out or altering the thermostat setting isolate electrical supply to the unit before removal of the lid. Ensure the lid to the junction box is refitted before power is switched back on.

The SBB 300 Trend cylinder can be fitted with all types of boilers. Standard boilers operate using room and cylinder thermostats. Please follow upper diagram: 'Wiring for Standard Boiler'.

4.6.1 Thermistor controlled boilers

Many popular boilers now use a thermistor principle. A thermistor temperature sensor is supplied with the boiler to attach to the cylinder. Temperature information is relayed back to the boiler control system.

Two sensor pockets (1) are provided to secure the sensor on the cylinder (see pt. 4.6.4).

The supplied motorised valve must be used in accordance with Building Regulation G3. This is wired from the supplied cylinder thermostat, wired as high limit stat Please follow lower diagram: 'Wiring diagram for Thermistor Controlled heat source'.

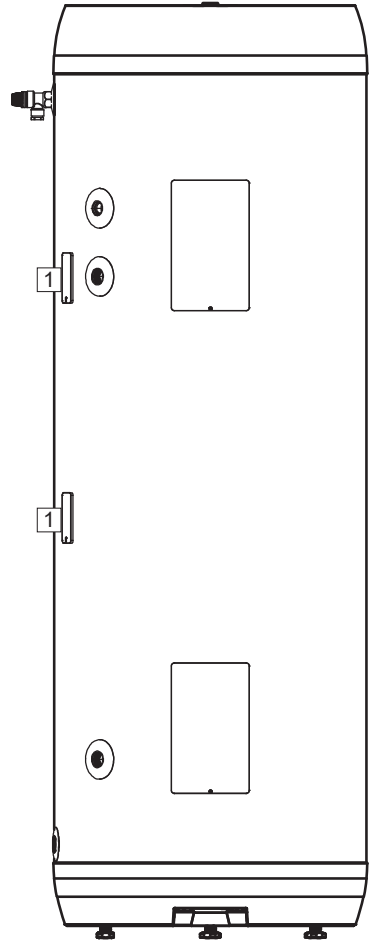

Y-plan wiring

Wiring diagram for Standard heat source

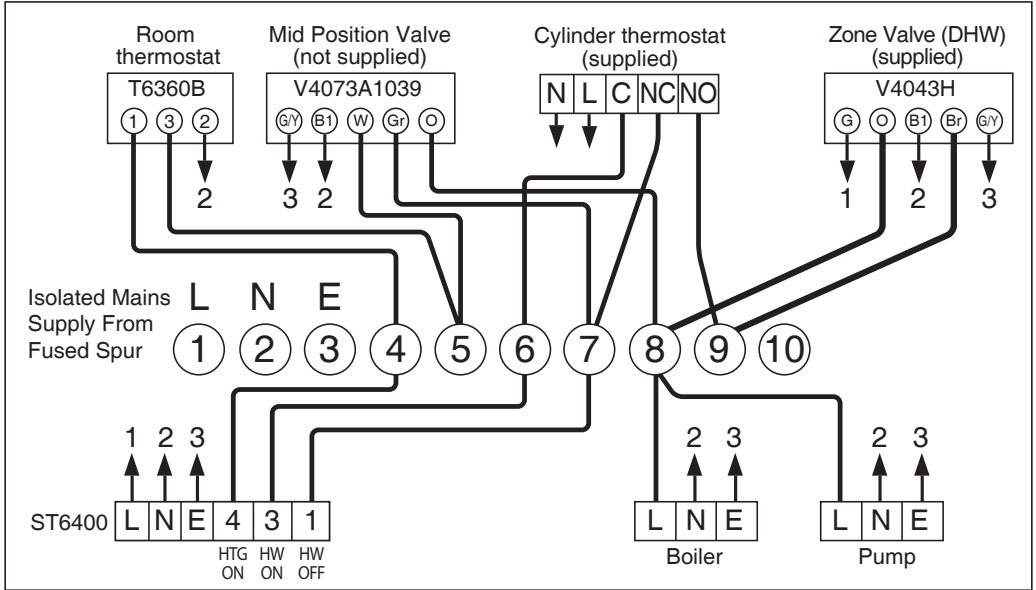

Y-plan wiring

Wiring diagram for Thermistor controlled heat source

Please contact heat source manufacturer for product specific wiring.

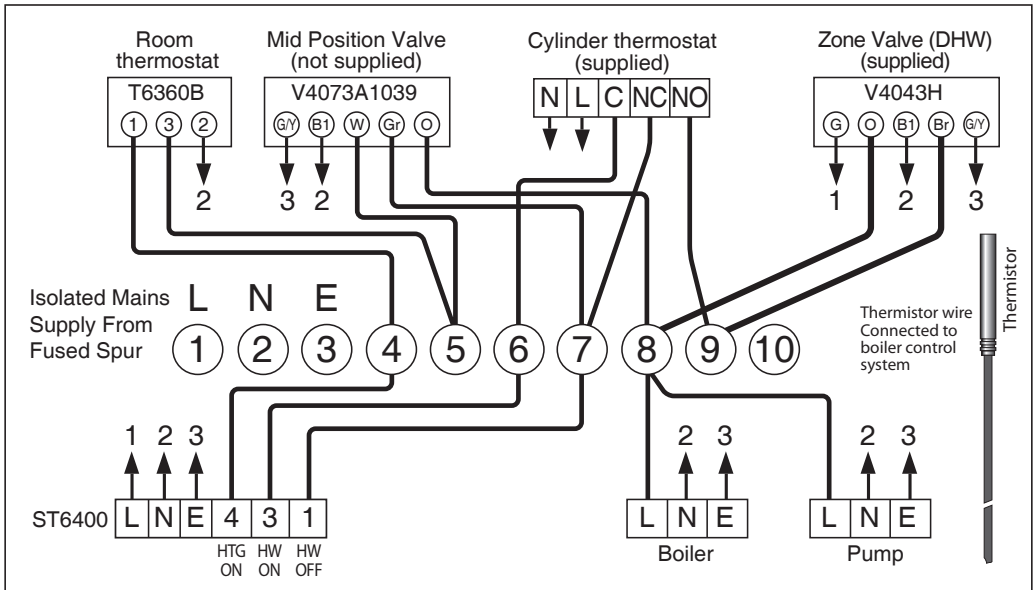

4.6.2 Fitting instructions

⚠ WARNING

❗	The product shall be filled with water before the power is switched on.
❗	Fixed electric fittings shall be used for installation in new homes or when changing an existing electrical setup in accordance with regulations.
❗	The mains cable shall withstand 90°C. A strain reliever must be fitted (supplied).

⚠ CAUTION

❗	The product must have a clearance for servicing of 40 cm in front of the cover / 10 cm over the top connection.
❗	If the mains cable is damaged, it must be replaced with cable of a quality that meets the requirements of the installation. The cable must be replaced by a qualified electrician.

4.6.3 Fitting recommendation

RECOMMENDATION

-	Mains cable (1) for wall socket/wall box should be hidden under one of the channels in the bottom of the product, see illustration at bottom of page.
-	For products with $\leq 2\text{kW}$ capacity, a $\geq 10\text{A}$ fuse / $\geq 1.5\#$ wire should be used*. For products with $\leq 3\text{kW}$ capacity, a $\geq 15\text{A}$ fuse / $\geq 2.5\#$ wire should be used (230V).

4.6.4 Temperature sensor installation

The product is equipped with two temperature sensor brackets which allows installation of a 6 or 8 mm. temperature sensor. To install the temperature sensor follow the instructions below.

1. Remove temperature sensor bracket (A) from tank body by gripping it and pulling straight out.
2. Insert temperature sensor (B) firmly into the appropriate grooves in the sensor bracket and place the temperature sensor cable in the cable slot (D).
An 8 mm. sensor (shown) fits in the upper grooves (C) while a 6 mm. sensor fits in the lower groove (E).
3. Refit the sensor bracket into the tank body, ensuring the bracket is inserted fully to establish proper contact between the sensor and the stainless steel inner tank surface. Make sure the sensor cable is positioned properly in the cable slot (D) to avoid potential damage to the cable.

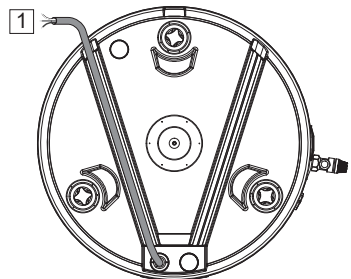
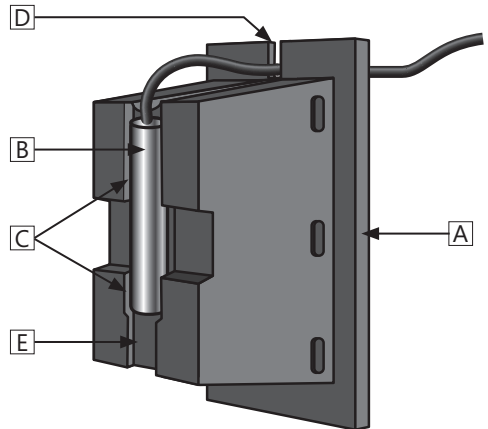

4.7 Handover to end-user

THE INSTALLER MUST:

Brief the end-user on safety and maintenance instructions.
Brief the end-user on settings and emptying the product.
Hand this installation manual over to the end-user.
Enter contact details on the type plate on the product.

5. USER GUIDE

5.1 Settings

5.1.1 Thermostat setting

The thermostat on the product is adjustable from 40-70°C. The thermostat should not be set lower than 65°C to prevent bacteria growth. To adjust the temperature:

- A) Disconnect the power supply.
- B) Remove the electric junction box cover (2) with a screwdriver.
- C) Adjust the temperature on the thermostat adjustment dial (4).
- D) The thermostat is adjustable from 40-70°C.

Refit the junction box cover (2) before connecting the power supply.

5.1.2 Resetting the safety thermostat

The safety thermostat on the product cuts out when there is a risk of overheating. This is reset by removing the cover (2) and pressing the 'Safety' button (5). If the thermostat cuts out repeatedly, contact the installer.

5.1.4 Adjusting the feet

The product is equipped with three factory-fitted feet (3), adjustable from 0-40 mm. Unscrew the feet a minimum of 15 mm from the bottom of the product. Adjust the feet individually until the product is standing stable and straight vertically and horizontally.

⚠ WARNING

Constant voltage present in the junction box. Before any electrical work is done, the power supply must be disconnected and secured against activation while the work is in progress.

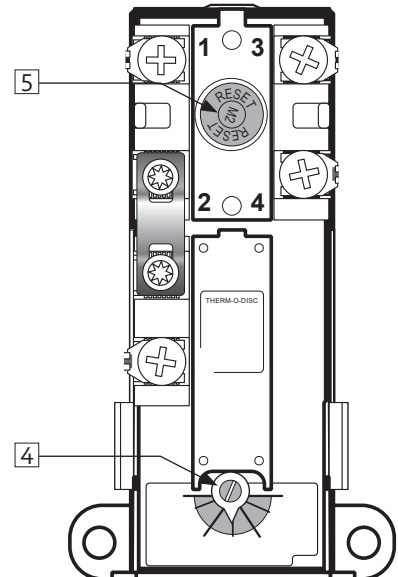
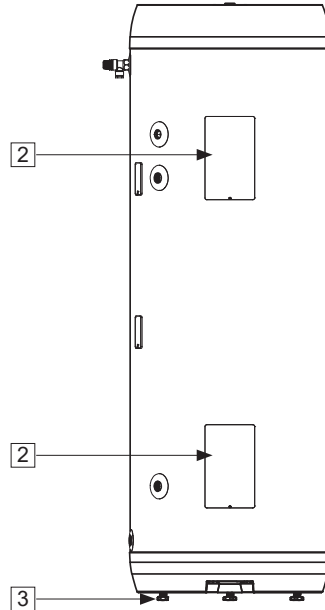

⚠ WARNING

The thermostat must never be dismantled or opened. This will compromise its function and cause risk of overheating. Warranty will cease.

6. SAFETY AND SERVICING

Maintenance must be carried out by a competent person.

6.1 Safety Cut-out

The safety cut-out operates if:

1. Wiring is incorrect.
2. The immersion heater thermostat or cylinder thermostat fails.
3. Thermostat is set too high.
4. Remember before resetting the safety cut-out or altering the thermostat setting, isolate electrical supply to the unit prior to removal of the electrical box lid.
5. Reduce thermostat setting and press the reset button. After adjustments are completed, ensure the lid to the electrical box is replaced.
6. If still out of operation, contact installer.

6.2 Intermittent or slow discharge from tundish

1. Turn off the electrical supply to the immersion heaters.
2. Turn off cold water supply valve.
3. Open a hot tap.
4. Turn the knob on the Temperature and Pressure Relief Valve (5) to the left and hold in this position for thirty seconds.
5. Attach a foot pump with a schraeder (car type) valve to the expansion vessel.
6. Pump up to 3 bar
7. Open cold water supply valve.
8. When water flows through open tap, close tap
9. Turn on electrical supply to the immersion heaters.

6.3 Continuous very hot water discharge from tundish

This indicates a malfunction of a thermal cut-out, operating thermostat or the combined temperature and pressure relief valve. Turn off the electrical supply to the immersion heater and also isolate an indirect unit from the boiler. Contact the installer or competent engineer.

6.4 Expansion vessel maintenance

The expansion vessels do not require annual maintenance and should not be tampered with unless an intermittent or slow discharge from the tundish occurs when water is being heated. In this situation, maintenance must be carried out by competent person and the precharge pressure must be restored to the original value. An annual

visual inspection is recommended. Important: To check the precharge the expansion vessel must be completely empty of water. If the precharge pressure is different from the value shown on the label it must be restored to the original value. Do not remove expansion vessel without depressurising the cylinder and draining 10 litres of water from the drain valve at the base of the cylinder.

6.5 Guarantee

Cylinder should be serviced annually and the log book should be updated in order to validate guarantee. The log book and service records act as guarantee document. For terms of guarantee please see the log book on page 27.

6.6 Servicing Procedure:

7.6.1 Expansion relief valve

Ensure that expansion relief valve works by manually opening to discharge water to tundish.

6.6.2 Pressure reducing valve

Isolate the cold water supply and open a ground floor cold tap. Unscrew the pressure reducing cartridge. Clean the filter mesh and the cartridge under running water. Replace cartridge ensuring that strainer is correctly located and reassemble the unit.

6.6.3 Expansion relief cartridge

Isolate the cold supply and open a ground floor cold tap. unscrew expansion relief headwork from valve body. Clean valve seat face and seating - do not scratch or damage either seat face or seating. Refit in reverse order. Do not overtighten.

6.6.4 Temperature and Pressure relief valve

Ensure that Temperature & Pressure Relief valve works by manually opening to discharge water to tundish.

6.6.5 Internal inspection

The immersion heater can be removed to provide visual inspection access to the cylinder.

7. FAULT FINDING GUIDE

7.1 Faults and fixes

If problems arise when the product is in use, check for possible faults and fixes in the table. If the problem is not shown in the troubleshooting

table or you are unsure what is wrong, contact the installer or Stiebel Eltron.

TROUBLESHOOTING		
Problem	Possible cause of fault	Possible solution
No hot water	Power supply interrupted.	Check that the fuse is set and the earth breaker has not tripped.
	Failure on heat source	Refer to the respective heat source manual.
	Thermostat has cut out.	Press the 'Reset' button on the safety thermostat; see 'User guide'.
	Heating element is defective.	Replace heating element. Contact auth. installer.
There is leakage/dripping from the safety valve/ there is often water on the floor by the cylinder in the morning	Leak in hot water pipe	Verify as follows: a) close the mixer valve, b) wait 2-3 hours, c) feel the mixer valve to see whether it is hot. If so, there is a leak in the hot water pipe or elsewhere. Contact auth. installer.
	Pressure reduction valve, water meter or blocked non-return valve on the water intake.	Fit expansion vessel which absorbs expansion during heating, and fit pressure reduction valve for stable water pressure inside the home. The pressure reduction valve is adjusted according to the set pressure in the expansion vessel. Contact auth. installer.
	Water pressure into the home is too high.	Try to flush with water through the safety valve. Open valve for approx. 1 minute. If the valve still leaks, it must be replaced. Contact auth. installer.
	The safety valve is worn or there are particles stuck between the membrane and the valve seat because the water is dirty	Verify as follows: a) cut the electric supply, b) unscrew the cover, c) visually check whether there is a leak from the heating element. If so, replace the gasket/heating element. Contact auth. installer.
Not enough hot water	Leak from heating element.	Raise the temperature on the thermostat to 70°C; see 'User guide'.
	High consumption in the home.	Switch to a larger water heater. Contact auth. installer.
Water temperature not high enough	The thermostat is set for low temperatures.	Raise the temperature on the thermostat to 70°C; see 'User guide'.
	Bleed from cold to hot water in taps.	Contact auth. installer.
Fuse/earth breaker trips repeatedly	Possible fault in the heater's electrical system.	Verify as follows: a) cut the electric supply, b) unscrew the cover, c) visually check the junction box for any problems. If so, contact auth. installer to check. Fit the cover.
Long time before the water reaches the tap	Long stretch of pipe from water heater to tap.	Fit circulation wire or heating cable to HW pipe. Or fit an auxiliary heater by the tap. Contact auth. installer.
Knocking in the pipes when the hot tap is closed	Large pressure increase when the tap is closed quickly.	Completely normal. Fit expansion vessel if troublesome. Contact auth. installer.
Important - please note: Always disconnect electrical supply before removing any electrical equipment covers		

7.2 Alternative discharge

Discharge pipes should be in metal and dedicated to the unvented cylinder. The pipe should have a continuous fall and should terminate in a safe and visible place.

Downward discharges at low level, i.e. up to 100 mm above external surfaces such as car parks, hard standings, grassed areas etc. are acceptable providing that where children may play or otherwise come into contact with discharges, a

wire cage or similar guard is positioned to prevent contact, whilst maintaining visibility.

Discharge at high level, i.e. into a metal hopper and metal down pipe with the end of the discharge pipe clearly visible (tundish visible or not) or onto a roof capable of withstanding high temperature discharges of water and 3 m from any plastics guttering system that would collect such discharges (tundish visible).

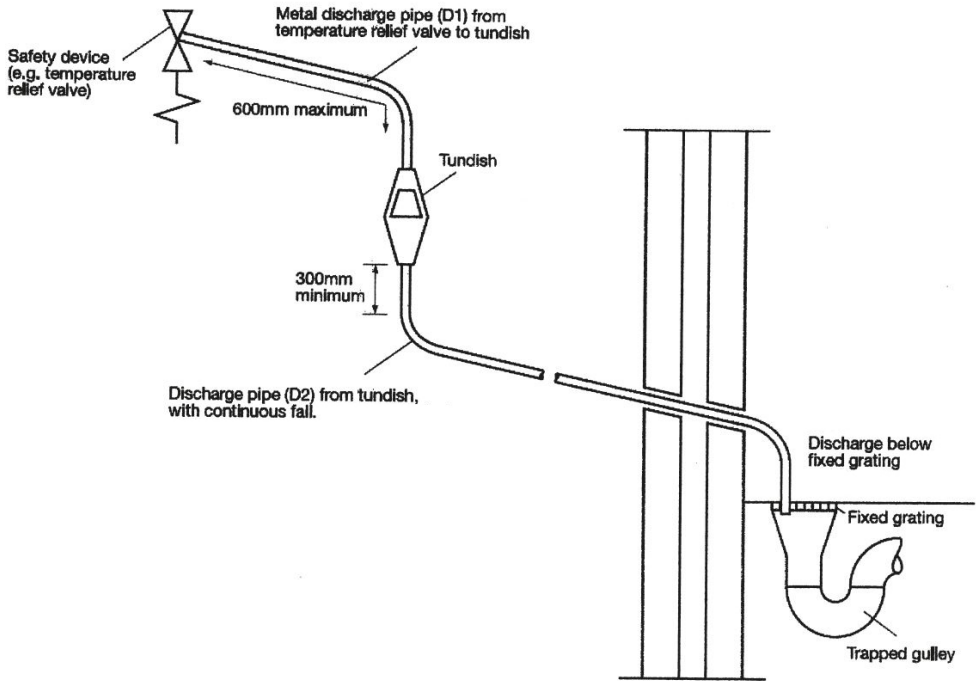

7.2.1 Single pipe discharge

Where a single pipe serves a number of discharges, such as in blocks of flats, the number served should be limited to not more than 6 systems so that any installation discharging can be traced reasonably

easily. The single common discharge pipe should be at least one pipe size larger than the largest individual discharge pipe to be connected. For further information contact your Building Control Office

Valve outlet size	Minimum size of discharge pipe D1	Minimum size of discharge pipe D2 from tundish	Minimum resistance allowed, expressed as a length of straight pipe (i.e. no elbows or bends)	Resistance created by each elbow or bend
G 1/2	15 mm	22 mm	Up to 9 m.	0.8 m.
		28 mm	Up to 18 m.	1.0 m.
		35 mm	Up to 27 m.	1.4 m.
G 3/4	22 mm	28 mm	Up to 9 m.	1.0 m.
		35 mm	Up to 18 m.	1.4 m.
		42 mm	Up to 27 m.	1.7 m.
G 1	28 mm	35 mm	Up to 9 m.	1.4 m.
		42 mm	Up to 18 m.	1.7 m.
		54 mm	Up to 27 m.	2.3 m.

7.3 Secondary return

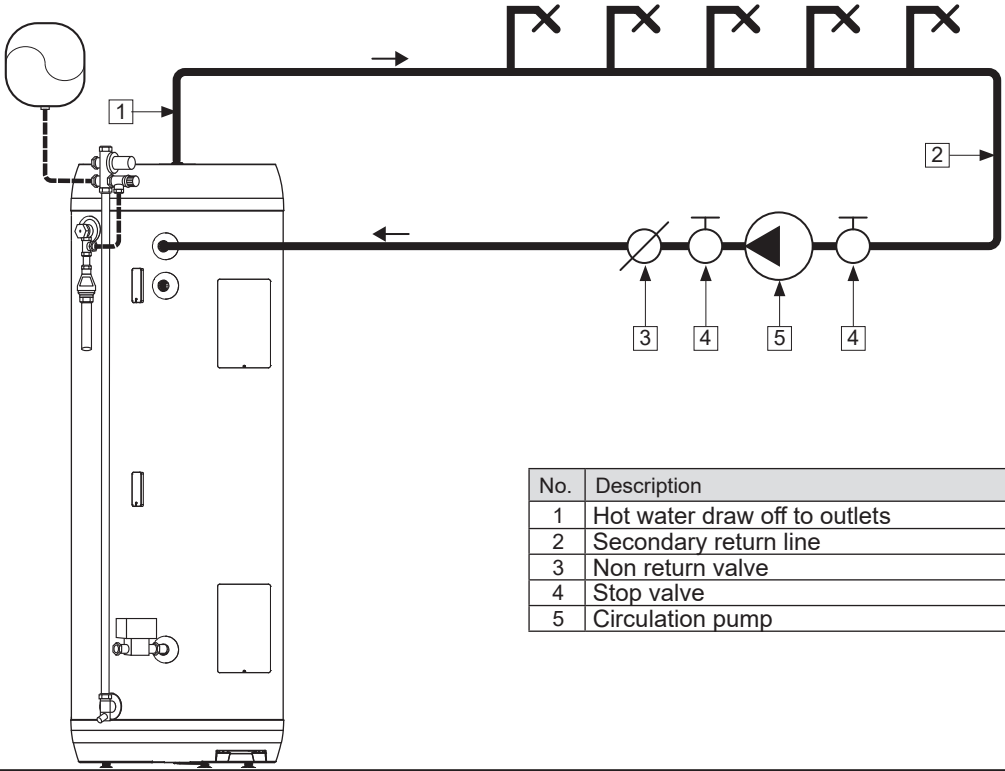

No.	Description
1	Hot water draw off to outlets
2	Secondary return line
3	Non return valve
4	Stop valve
5	Circulation pump

7.4 Spare parts

Pressure reducing
valve cartridge
Part No. REDC
355030 - 3 Bar

Expansion valve
6.0 Bar

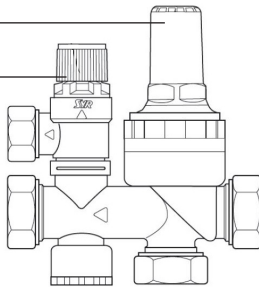

Description	Part No.
Multibloc valve	355030
Temperature & pressure relief valve	550853
Pressure reducing valve	RED355030
Elbow drain valve	250445
Immersion heater, Incoloy 3 kW	71242
Honeywell 2 port valve	92000
Fittings kit	
Cylinder thermostat	80345
Immersion thermostat	80314
Expansion vessel	AX 24

7.4.1 Obtaining spare parts

To obtain the address of a local stockist contact installer, see Log Book on page 27 in this manual.

8. TECHNICAL DATA

8.1 Data table

Description	Unit	SBB 300 Trend
Part number	No.	11009123
Product number	GTIN	707064400439
Actual capacity of the water tank at 20°C	l.	281
Outer diameter of the tank	mm	595
Height of the appliance	mm	1750
Gross weight of the appliance	kg	63
Net weight of appliance	kg	58
Net weight of appliance once filled with sanitary water	kg	340
Material of tank and integrated heat exchanger	-	1.4521 / 1.4521
Material of element	-	Incoloy 825
Thermal insulation material	-	PUF
Thermal insulation of the tank, average thickness	mm	50
IP classification	IP	21
Standby heat losses / 24 hour	kWh/24h	1.65
Standby heat losses	Watts	69
Hot water capacity - mixed to 40°C	l.	416
Heating time (coil)	min.	51.8
Reheat time (1) (70%) (coil)	min.	36.3
Dedicated Heat Pump volume	l.	104
Primary Heating Power (1) (coil)	kW	15.2
Primary flowrate for Reheat time and primary heating power	l/h	900
Primary Heat exchanger pressure drop (1)	mBar	50
Heat up time element	min.	246
Reheat time (1) (70%) 1 element	min.	172
ErP class	Rating	B
Pressure information		
Maximum design pressure of cylinder (rated pressure)	MPa/Bar	1 / 10
Maximum design pressure of heating coil	MPa/Bar	1 / 10
Operating pressure of cylinder	MPa/Bar	3.0
Operating pressure of heating coil	MPa/Bar	2.5
Max. operating temperature of cylinder	°C	75
Max. operating temperature of heating coil	°C	99
Expansion solution	-	Aquasystem 3 Bar
Expansion vessel capacity	l.	24
Heat Exchanger information		
Primary heat exchanger volume	l.	17
Primary heat exchanger surface area	m ²	3.1
External diameter - pipe	mm	ø25.6
Hydraulic connections		
Secondary return	mm	1/2"
Primary heat exchanger flow	Inch	3/4"
Primary heat exchanger return	Inch	3/4"
Cold water	Inch	3/4"
Hot water	Inch	3/4"
Immersion heater	Inch	5/4"
Expansion Relief Valve	Inch	1/2"
T&P valve (factory fitted)	Inch	1/2"
Pressure reducing valve	Inch	ø22
Temperature sensor sleeve diameter	mm	8 / 6
Electrical characteristics		
Supply voltage and frequency	V/Hz	230/50
Current	A	13
Power of the electrical resistance	W	3000
Electrical installation	-	IEEE regs
Thermostat type - cylinder	-	Surface
Immersion capacity	kW	2.8
Immersion Heater - Phase	Phase	Single
Immersion heater - Voltage	Volt	230
Immersion thermostat - temp range	°C	40-70
Immersion thermostat - set temp	°C	60
Indirect thermostat - temp range	°C	40-70
Indirect thermostat - set temp	°C	60
Safety		
Safety valve opening pressure +/- 5%	Bar	6
T&P valve opening pressure/Temp.	Bar/°C	10/90
Safety thermostat cutout - immersion	°C	85
Safety thermostat cutout - cylinder	°C	85
Packaging		
Width of box	mm	610
Depth of box	mm	610
Height of box	mm	1780
Weight of box	Kg.	63

IT IS THE RESPONSIBILITY OF THE INSTALLER TO COMPLETE THIS LOG BOOK AND PASS IT ON TO THE CUSTOMER. FAILURE TO DO SO MAY INVALIDATE THE CYLINDER GUARANTEE

The code of practice for the installation, commissioning & servicing of mains pressure hot water storage

Installation, Commissioning and Service Record Log Book

CUSTOMER DETAILS

NAME

ADDRESS

TEL No.

IMPORTANT

1. Please, keep the Log Book in a safe place for future reference.
2. This Log Book is to be completed in full by the competent person(s) who commissioned the equipment and then handed to the customer. When this is done, the Log Book is a commissioning certificate that can be accepted as evidence of compliance with the appropriate Building Regulations.
3. Failure to install and commission this appliance to the manufacturer's instructions may invalidate the guarantee.

The above does not affect your statutory rights.

INSTALLER & COMMISSIONING ENGINEER DETAILS

INSTALLER DETAILS

COMPANY NAME	DATE
ADDRESS	
INSTALLER NAME	TEL No.
REGISTRATION DETAILS	
REGISTERED OPERATIVE ID CARD No. (IF APPLICABLE)	

COMMISSIONING ENGINEER (IF DIFFERENT)

NAME	DATE
ADDRESS	
TEL No.	
REGISTRATION DETAILS	
REGISTERED OPERATIVE ID CARD No. (IF APPLICABLE)	

APPLIANCE & TIME CONTROL DETAILS

MANUFACTURER	MODEL		
CAPACITY	litres	SERIAL No.	
TYPE	UNVENTED		
TIME CONTROL	PROGRAMMER <input type="checkbox"/>	or	TIME SWITCH <input type="checkbox"/>

IT IS THE RESPONSIBILITY OF THE INSTALLER TO COMPLETE THIS LOGBOOK AND PASS IT ON TO THE CUSTOMER. FAILURE TO DO SO MAY INVALIDATE THE CYLINDER GUARANTEE

COMMISSIONING PROCEDURE INFORMATION

BOILER PRIMARY SETTINGS (INDIRECT HEATING ONLY) ALL BOILERS

IS THE PRIMARY A SEALED OR OPEN VENTED SYSTEM? SEALED OPEN
WHAT IS THE BOILER FLOW TEMPERATURE? °C

ALL MAINS PRESSURISED SYSTEMS

WHAT IS INCOMING STATIC COLD WATER PRESSURE AT THE INLET TO THE
PRESSURE REDUCING VALVE? bar
HAS STRAINER (IF FITTED) BEEN CLEANED OF INSTALLATION DEBRIS? YES NO
HAS A WATER SCALE REDUCER BEEN FITTED? YES NO
WHAT TYPE OF SCALE REDUCER HAS BEEN FITTED? _____

UNVENTED SYSTEMS

ARE COMBINED TEMPERATURE AND PRESSURE RELIEF VALVE
AND EXPANSION VALVE FITTED AND DISCHARGE TESTED? YES NO
IS PRIMARY ENERGY SOURCE CUT OUT FITTED
(NORMALLY 2 PORT VALVE)? YES NO
WHAT IS THE PRESSURE REDUCING VALVE SETTING (IF FITTED)? bar
WHERE IS OPERATING PRESSURE REDUCING VALVE SITUATED? YES NO
HAS THE EXPANSION VESSEL OR INTERNAL AIR SPACE BEEN CHECKED? YES NO
WHAT IS THE HOT WATER TEMPERATURE AT THE NEAREST OUTLET? °C

ALL PRODUCTS

DOES THE HOT WATER SYSTEM COMPLY WITH
THE APPROPRIATE BUILDING REGULATIONS? YES
HAS THE SYSTEM BEEN INSTALLED AND COMMISSIONED
IN ACCORDANCE WITH THE MANUFACTURER'S INSTRUCTIONS? YES
HAVE YOU DEMONSTRATED THE OPERATION OF THE
SYSTEM CONTROLS TO THE CUSTOMER? YES
HAVE YOU LEFT ALL THE MANUFACTURER'S
LITERATURE WITH THE CUSTOMER? YES

COMPETENT PERSON'S
SIGNATURE

CUSTOMER'S
SIGNATURE

*(To confirm demonstrations of equipment and
receipt of appliance instructions)*

**PLEASE FOLLOW THE INSTALLATION AND COMMISSIONING INSTRUCTIONS
IN THE INSTALLATION MANUAL SUPPLIED WITH THE EQUIPMENT (this document)**

GUARANTEE

The guarantee conditions of our German companies do not apply to appliances acquired outside of Germany.

In countries where our subsidiaries sell our products a guarantee can only be issued by those subsidiaries. Such guarantee is only granted if the subsidiary has issued its own terms of guarantee. No other guarantee will be granted.

We shall not provide any guarantee for appliances acquired in countries where we have no subsidiary to sell our products. This will not affect warranties issued by any importers.

Environment and recycling

We would ask you to help protect the environment. After use, dispose of the various materials in accordance with national regulations. This product is recyclable and should be taken to an environmental recycling centre.

Customer service

In case of problems that cannot be resolved with the aid of the troubleshooting guide in this installation manual, contact the installer, see contact information on page 28.

Removing the product

- A) Disconnect the power supply.
- B) Shut off incoming cold water supply.
- C) Empty the product of water, see pt. 3.12.
- D) Disconnect all pipes.
- E) The product can now be removed.

SERVICE INTERVAL RECORD

It is recommended that your hot water system is serviced regularly and that your service engineer completes the appropriate Service Interval Record below.

SERVICE PROVIDER

Before completing the appropriate Service Interval Record below, please ensure you have carried out the service as described in the manufacturer's instructions and in compliance with all relevant codes of practice.

SERVICE 1	DATE:
ENGINEER NAME	_____
COMPANY NAME	_____
TEL No.	_____
COMMENTS	_____
SIGNATURE	_____

SERVICE 2	DATE:
ENGINEER NAME	_____
COMPANY NAME	_____
TEL No.	_____
COMMENTS	_____
SIGNATURE	_____

SERVICE 3	DATE:
ENGINEER NAME	_____
COMPANY NAME	_____
TEL No.	_____
COMMENTS	_____
SIGNATURE	_____

SERVICE 4	DATE:
ENGINEER NAME	_____
COMPANY NAME	_____
TEL No.	_____
COMMENTS	_____
SIGNATURE	_____

SERVICE 5	DATE:
ENGINEER NAME	_____
COMPANY NAME	_____
TEL No.	_____
COMMENTS	_____
SIGNATURE	_____

SERVICE 6	DATE:
ENGINEER NAME	_____
COMPANY NAME	_____
TEL No.	_____
COMMENTS	_____
SIGNATURE	_____

SERVICE 7	DATE:
ENGINEER NAME	_____
COMPANY NAME	_____
TEL No.	_____
COMMENTS	_____
SIGNATURE	_____

SERVICE 8	DATE:
ENGINEER NAME	_____
COMPANY NAME	_____
TEL No.	_____
COMMENTS	_____
SIGNATURE	_____

SERVICE 9	DATE:
ENGINEER NAME	_____
COMPANY NAME	_____
TEL No.	_____
COMMENTS	_____
SIGNATURE	_____

SERVICE 10	DATE:
ENGINEER NAME	_____
COMPANY NAME	_____
TEL No.	_____
COMMENTS	_____
SIGNATURE	_____

When all the above services have been completed, please contact installer or Stiebel Eltron for an additional service interval record sheet.

STIEBEL ELTRON

STIEBEL ELTRON GmbH & Co. KG

Dr.-Stiebel-Straße 33
37603 Holzminden
Tel. 05531 702-0
Fax 05531 702-480
info@stiebel-eltron.de
www.stiebel-eltron.de

United Kingdom and Ireland

STIEBEL ELTRON UK Ltd.

Unit 12 Stadium Court
Stadium Road
CH62 3RP Bromborough
Tel. 0151 346-2300
Fax 0151 334-2913
info@stiebel-eltron.co.uk
www.stiebel-eltron.co.uk

Manufactured by
OSO Hotwater AS

© This installation manual and all its content is protected by copyright and may be reproduced or distributed only with written consent from the manufacturer. We reserve the right to make changes without notice.