

# Front View (0.15 : 1)

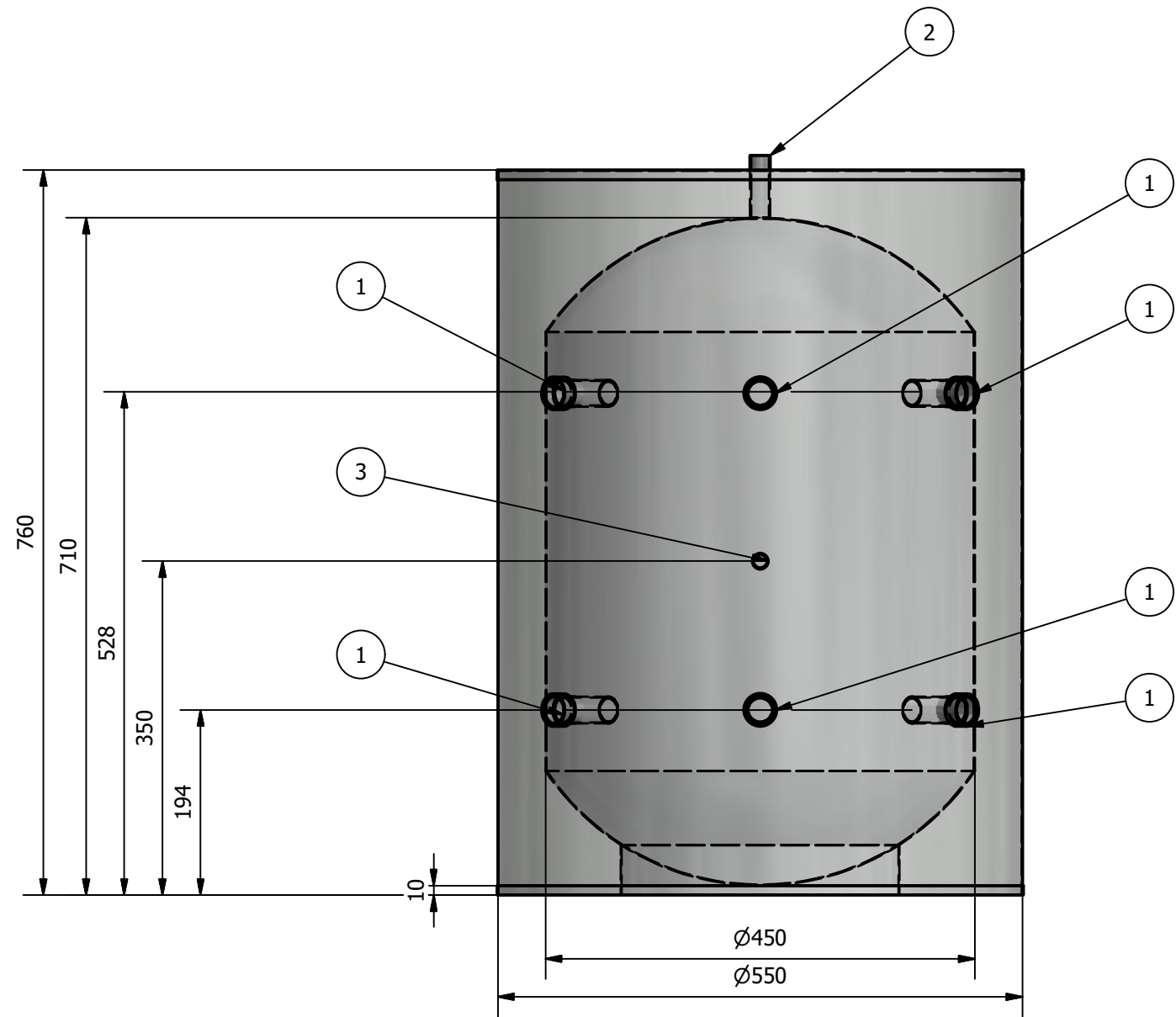

PARTS LIST		
ITEM	QTY	PART
1	6	28mm Compression Fitting (65mm Extended)
2	1	G 1/2 INT - 65 mm Extended (Mild Steel)
3	1	Mild Steel Stat Pocket (Mild Steel)

# Top View (0.15 : 1)

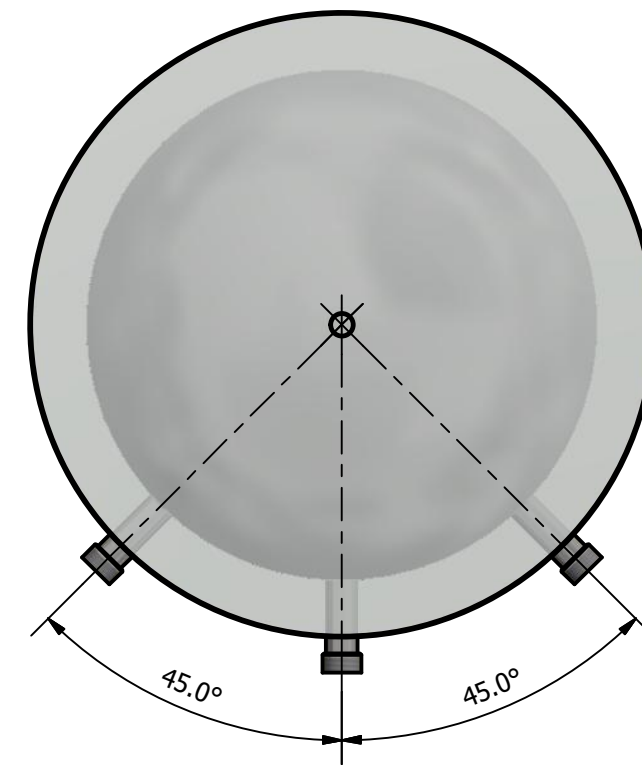

	PRIMARY:	SECONDARY:	ADDITIONAL NOTES:
MAX WORKING PRESSURE:	N/A BarG	N/A BarG	1. Stand Size = 915 x 100 x 1 mm
DESIGN PRESSURE:	N/A - N/A BarG	0 - N/A BarG	2. Approx Dry Weight = - kg
TEST PRESSURE:	N/A BarG	N/A BarG	3.
DESIGN TEMPERATURE:	N/A - N/A °C	N/A - N/A °C	4.
STANDING HEAT LOSS:	- kWh/24h at 60°C & 21°C		5.



WORLD HEAT  
CYLINDERS  
CYLINDER GENERATOR

This drawing, and information contained within, is the property of World Heat Ltd. and must not be copied in whole/part or used for manufacture/otherwise disclosed without the prior written consent of the company.

TITLE:	SPEC100MSBUFF(MIDSUMMERSPEC)		
DESCRIPTION:	100L MILD STEEL BUFFER		
QUANTITY:		CASE:	None
CUSTOMER:	MIDSUMMER	WH REF.:	-
DESIGNED BY:	Beth Hindley	DATE:	26/01/2022
CHECKED BY:		DATE:	
APPROVED BY:		DATE:	
DRAWING NO.:	0	REVISION:	-
Unit 4, Tudor Industrial Estate, Dukinfield, SK16 4RN. Tel: 0161 343 8610 Email: sales@worldheat.co.uk			