

# SolShare Installation Manual





## UK - AE-PN-348-A4

This manual is intended for installations in the UK of SolShare model SOLSHARE-3P-35A-03.

It is subject to change. Please check our website at <https://allumeenergy.com/document-library> for the most up-to-date manual version.

Version	Date released	Updates
A1	24/09/2021	– Based on AE-PN-101-V5.0
A3	06/10/2021	– Changes to cable diagrams
A4	05/11/2021	– Addition of earth screws to ‘What’s in the box’ – Addition of clarification on using earth screws during ‘SolShare installation’ – New warning around correct orientation of seals when closing the SolShare’s cover

© Copyright – Allume Energy - All rights reserved.

This manual accompanies our equipment for use by the end users.

The technical instructions and illustrations contained in this manual are to be treated as confidential and no part may be reproduced without the prior written permission of Allume Energy and end users may not divulge the information contained herein or use this manual for purposes other than those strictly connected with correct use of the equipment.

All information and specifications are subject to change without notice.

# Summary

---

Commissioning Document	p06
I/ What's in the box	p08
II/ Mounting the SolShare	p10
A. Installation site selection	p10
B. Installation	p11
III/ Electrical connection	p12
A. Input / output connections	p12
B. Running current transformer tails	p16
C. Labelling	p17
IV/ Commissioning	p18
A. Preparing the SolShare for commissioning	p18
B. Commissioning the SolShare	p18

---

# Hello

Thank you for purchasing a SolShare system. You are supporting the growth of cutting edge Australian made solar technology. Due to the novelty of this product, this installation will likely be different from any other piece of solar technology you have installed in the past. As a result, please follow the guidelines in this manual carefully. Installations that contravene these guidelines are not covered under warranty unless a written exemption from Allume is provided.

Your system is designed to meet all UK conditions, regulations and codes. This guide provides the general instruction of the installation procedure of the SolShare.

If you have questions or feedback on the product or this manual, feel free to reach out to Allume on +44 20 3239 0409 and ask for a technical representative. Otherwise, you can email [support@allumeenergy.com](mailto:support@allumeenergy.com) with any queries.

---

## List of supplementary documents online



[SolShare 3P-35A-03 datasheet](#)



[SolShare labelling advice - UK](#)



[SolShare pre-installation checklist](#)



[Commissioning app guide](#)



[SolShare system and SLD design guidelines - UK](#)



[How to set-up/change Wi-Fi credentials](#)

For most up to date versions of all documents (including this Installation Manual), scan this QR code or go to <https://allumeenergy.com/document-library/>



# Commissioning Document

To be completed during installation and entered into the commissioning app

**Leave a copy of this page on site for service purposes.**

Installer name: ..... Company: .....

Electrician license number: .....

Serial Number: 3P\_35A\_

Allume SIP training certification number: .....

Installation Address: .....

County: ..... Postcode: ..... Country: .....

## Unit Connection Identifier

SolShare Connection	Unit Connected (eg: Apt 1, Unit B, Landlord supply, No connection)	
	Single-Phase	Three-Phase
L1-1	.....	OR .....
L2-1	.....	OR .....
L3-1	.....	OR .....
L1-2	.....	OR .....
L2-2	.....	OR .....
L3-2	.....	OR .....
L1-3	.....	OR .....
L2-3	.....	OR .....
L3-3	.....	OR .....
L1-4	.....	OR .....
L2-4	.....	OR .....
L3-4	.....	OR .....
L1-5	.....	OR .....
L2-5	.....	OR .....
L3-5	.....	OR .....

# Handling and Safety Instructions

This guide is provided to help the installer understand the standard SolShare installation procedure.

Installations may vary depending on the existing electrical infrastructure and local electrical safety standard. It is the responsibility of the electrician to ensure their installation meets the local electrical safety standard.

During installation, testing and inspection, adherence to all the handling and safety instructions is mandatory. **Failure to do so may result in injury or loss of life and damage to the equipment.**

## SAFETY SYMBOLS INFORMATION

The following safety symbols are used in this document. Familiarise yourself with the symbols and their meaning before installing or operating the system:

 **Warning:**  
xxxxx xxxx xxxx xxx xxxx xx xxxx xxx xxxx

This symbol denotes a critical safety instruction that must be followed to ensure safety of installer and safe operation of the SolShare once commissioned. This box is sometimes denoted in green to provide further emphasis.

 **Warning:**  
xxxxx xxxx xxxx xxx xxxx xx xxxx xxx xxxx

 **Important:**  
xxxxx xxxx xxxx xxx xxxx xx xxxx xxx xxxx

This symbol indicates an instruction which will ensure proper operation of the SolShare once commissioned or will help with the installation efficiency. This same box is sometimes denoted in green to provide further emphasis.

 **Important:**  
xxxxx xxxx xxxx xxx xxxx xx xxxx xxx xxxx

## IMPORTANT SAFETY INSTRUCTIONS

**SAVE THESE INSTRUCTIONS. This manual contains important instructions for the SolShare 3P-35A that shall be followed during installation and maintenance of the power division control system.**

**WARNING:** Opening of the SolShare must only be performed by a certified electrician.

**WARNING:** This equipment is connected to multiple sources of supply. Isolate all supplies before working on this equipment. Each input circuit and each output circuit represent a source of supply.

**WARNING:** The specified shutdown procedure must be followed prior to working on this equipment.

**WARNING:** This equipment must be permanently earthed.

**WARNING:** This product relies on passive cooling, install in a well-ventilated location in accordance with the mounting instructions.

**CAUTION:** HEAVY OBJECT – This product has a weight of approximately 38kg. Un-boxing and mounting the product requires 2 people.

**CAUTION:** Residual Current Devices and Earth Leakage Breakers must not be used as Overcurrent Protection devices in Solshare Output circuits.

**CAUTION:** The SolShare will impose a current dependent voltage drop/rise which should be taken into account during design of the installation. Specifications are given in the Technical Data sheet.

**CAUTION:** The unit must be operated according to the technical specification datasheet provided with the unit.

**CAUTION:** Installations may vary depending on the existing electrical infrastructure and local electrical safety standard. It is the responsibility of the electrician to ensure their installation meets the local electrical safety standard.

**NOTE:** Use only copper conductors rated for a minimum of 90 degrees Celsius.

**NOTE:** The symbol  appears at grounding points within the SolShare equipment. This symbol is also used in the manual.



**Warning:**

- Make sure to read over, fully understand and strictly follow the detailed instructions of this installation manual and other related regulations before installing the equipment.
- Any violation could result in personal death or injury, or damage to the device.
- Installation is only to be conducted by a certified electrician.
- This guide is provided to help the installer understand the standard SolShare installation procedure. Installations may vary depending on the existing electrical infrastructure and local electrical safety standard. It is the responsibility of the electrician to ensure their installation meets the local electrical safety standard.
- This product has a weight of approximately 38kg. Un-boxing and mounting the product requires 2 people.

# I/ What's in the box

## Check for Transport Damage

Make sure the SolShare is intact following transportation. If there are any signs of visible damage, please contact your dealer immediately. Carefully check that all of the components have been supplied. If anything is missing, contact your dealer.

		<p>SolShare unit</p> <p>x 1</p>	<p>Label pack</p>	<p>Mounting bracket</p> <p>x 2</p>
		<p>Fastener</p> <p>x 4</p>	<p>Locking plate</p> <p>x 1</p>	<p>Earth screws</p> <p>x 10</p>
				<p>CT connection aid</p> <p>x 1</p>



## Installation overview

A single SolShare unit can distribute the power generated from a single solar system to up to 15 single-phase or 5 three-phase units (or a combination of the two).

The SolShare takes a single three-phase input from a grid-connected solar inverter(s) and connects to each participating unit on the load side of their retail electricity meter at the unit main switchboard.

A Tenancy Main Switch (Inverter Supply) is required on each output (ideally located within the unit main switchboard) between the SolShare and each unit's main switch. In series with this, additional SolShare Maintenance Isolators (Grid) are recommended to allow for the isolation of the SolShare and the solar supply of any of the connected units.

A typical installation configuration is displayed below. The configuration displayed below may differ from your installation configuration. Please refer to your Project Single Line Diagram (SLD) for the connection and switchgear configuration for your specific project. Guidance on this is covered below and in the supporting *SolShare System and SLD Design Guide UK* document that is available from Allume. It is highly recommended that a hardcopy of the project SLD be kept onsite at all times.

More information about labelling can be found in the *SolShare Labelling Advice UK* document.

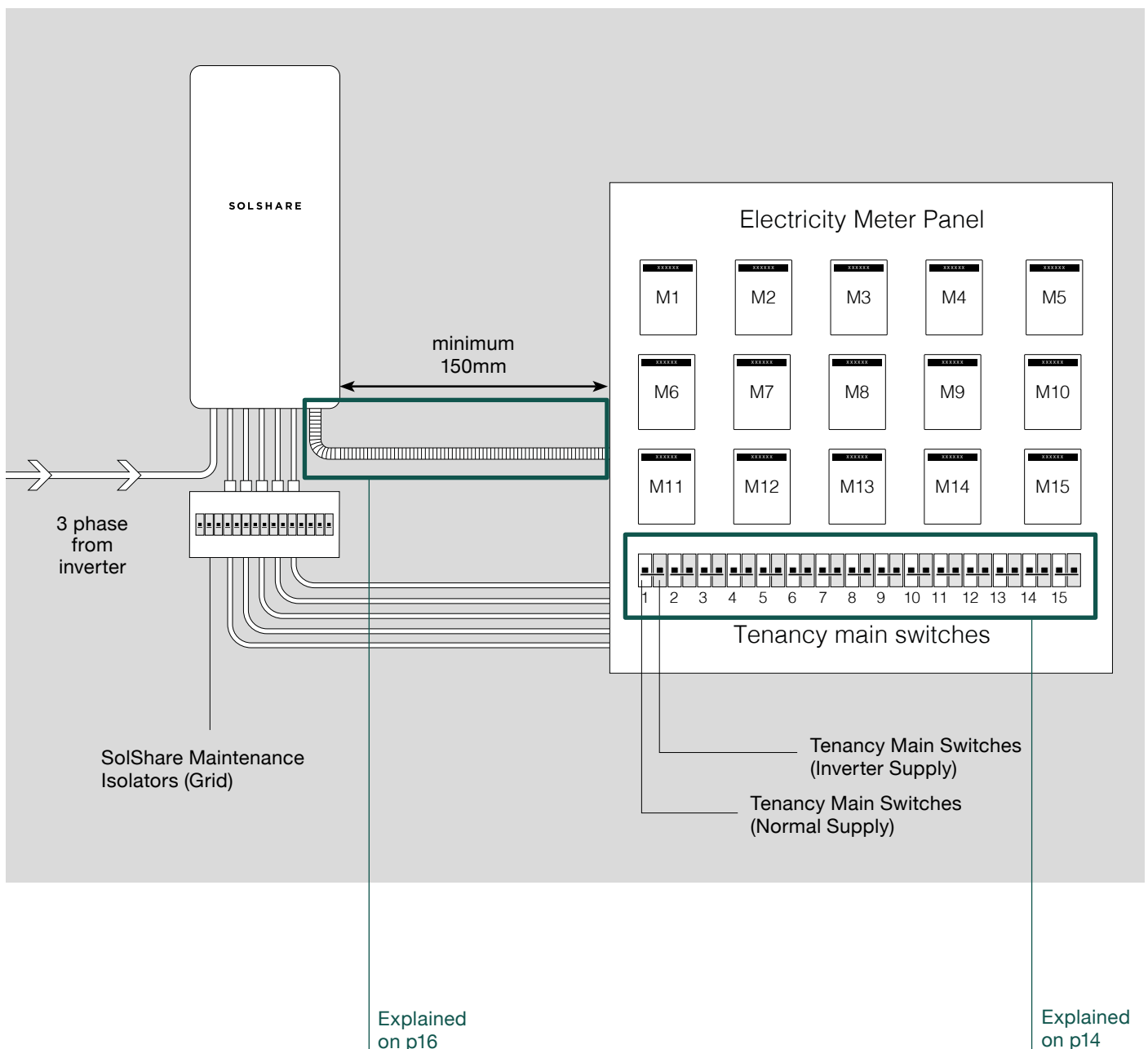

### Warning:

The neutral for the SolShare must be wired directly to the main neutral bar inside the main switchboard. It must **not** be connected to an individual apartment's neutral.

# II/ Mounting the SolShare

## A. Installation site selection

To minimise cabling required, the SolShare should be mounted as close to the main switchboard (tenancy isolator board) as possible.

To allow for easy installation and maintenance, ensure that there is adequate space surrounding the SolShare and that it is mounted at a convenient height. Please ensure the following mounting requirements are also met when selecting the location of the SolShare.

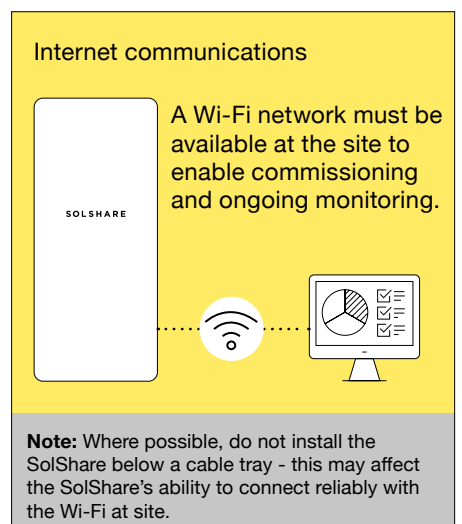
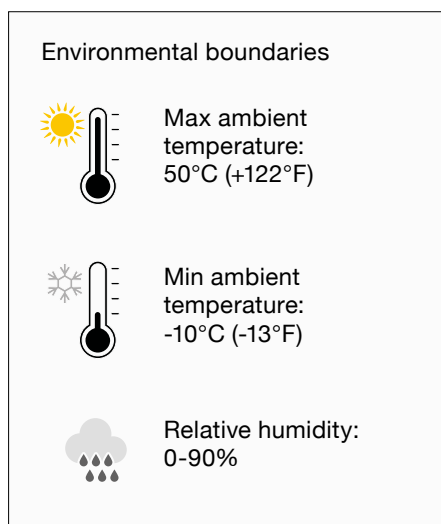
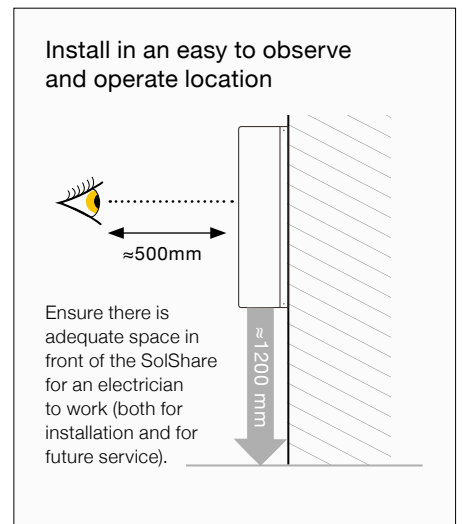
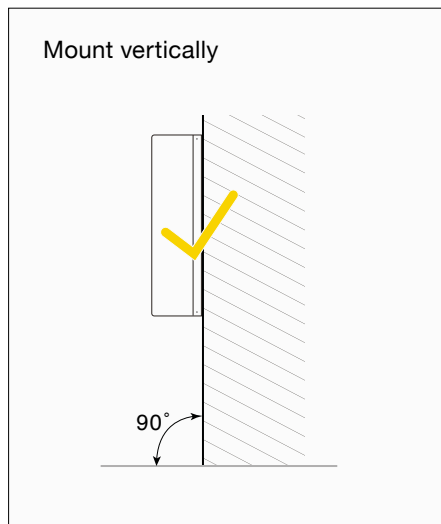
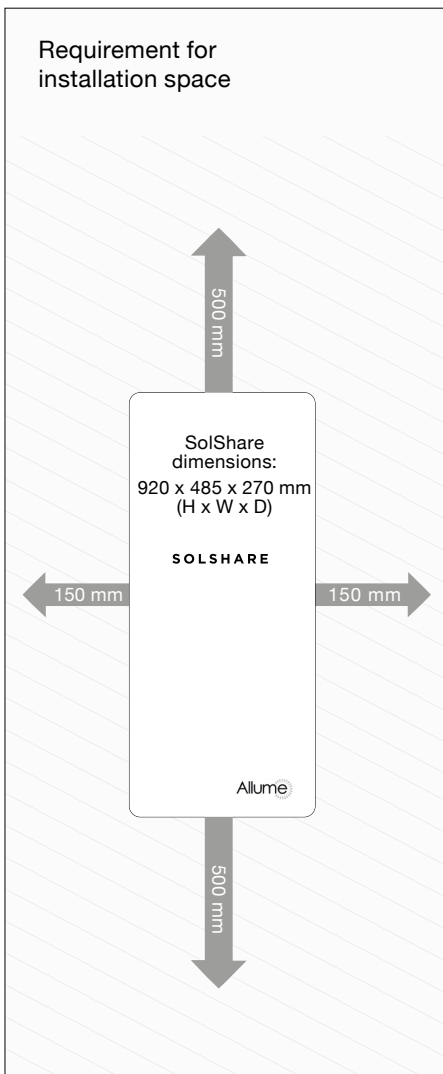
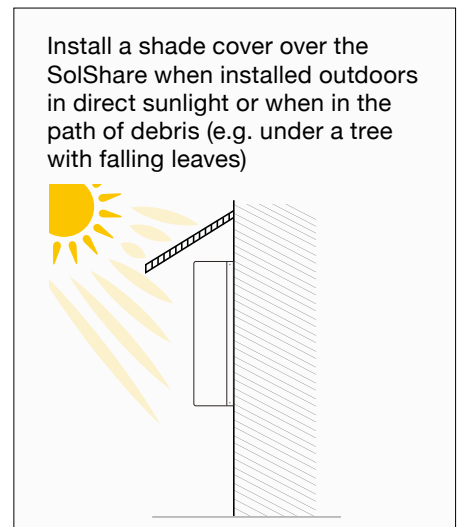
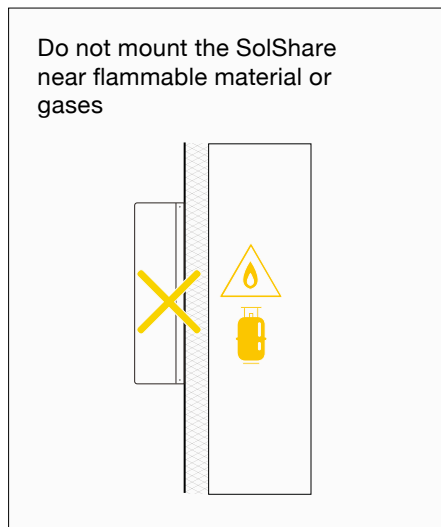
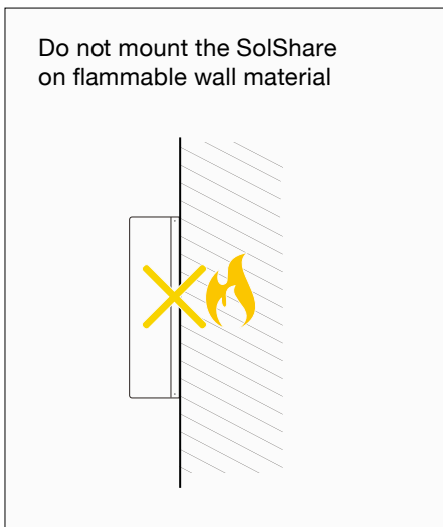

## B. Installation

Follow the steps below to mount the brackets and enclosure:

1. Firmly secure the mounting brackets to the chosen wall for installation. Allume Energy recommend using the provided fasteners to attach the brackets into a suitable stone or masonry wall. If another wall material has been chosen for installation, please use suitable fasteners with at least 30kg shear force per fastener.
2. Lift the SolShare onto the mounting brackets as directed in the diagram. Check both top and bottom brackets are secure.
3. Insert the locking bolt through the SolShare top mounting bracket as shown and secure at both ends. A padlock can be used to lock the SolShare to the wall.
4. Ensure the SolShare is securely fastened to the wall and locked into place.



### Important:

- The mounting wall and fastener selection is at the discretion of the installer. Allume Energy take no responsibility in the appropriate site selection for the SolShare or the appropriate bracket fastener choice.
- Weight rating fasteners should be rated to at least 30kg of shear force per fastener.

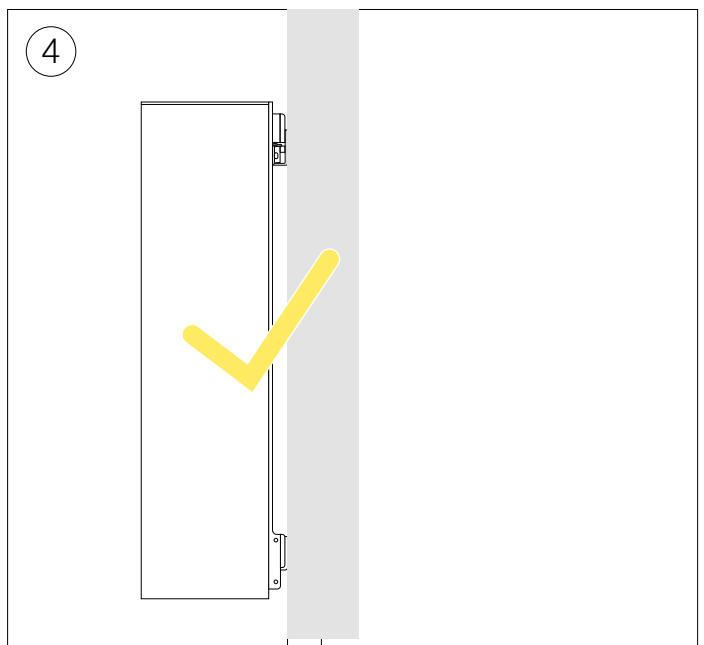
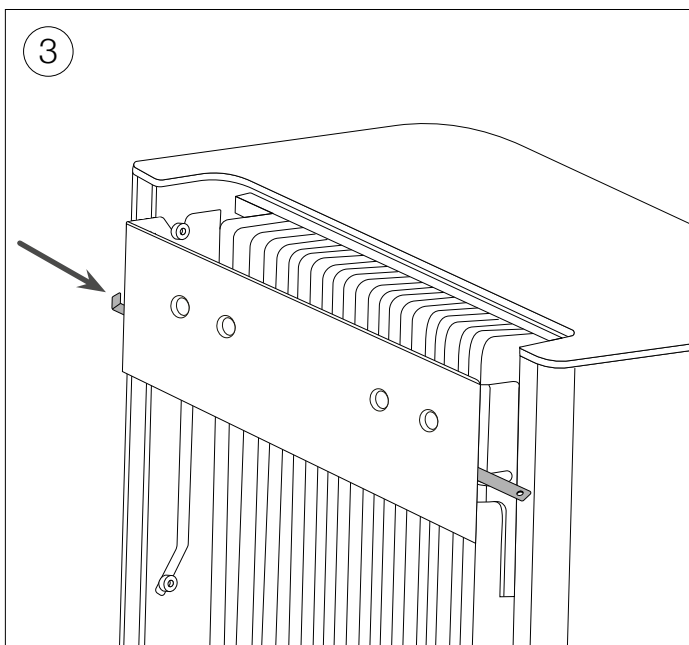
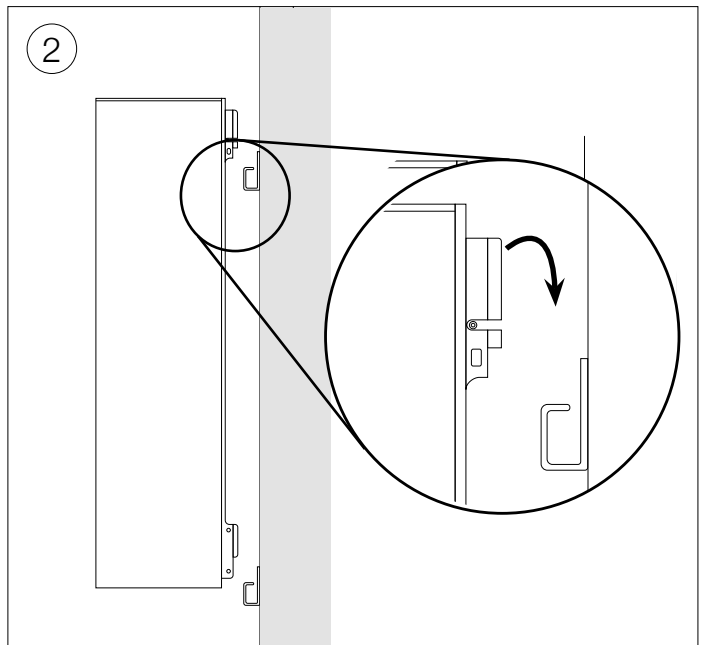
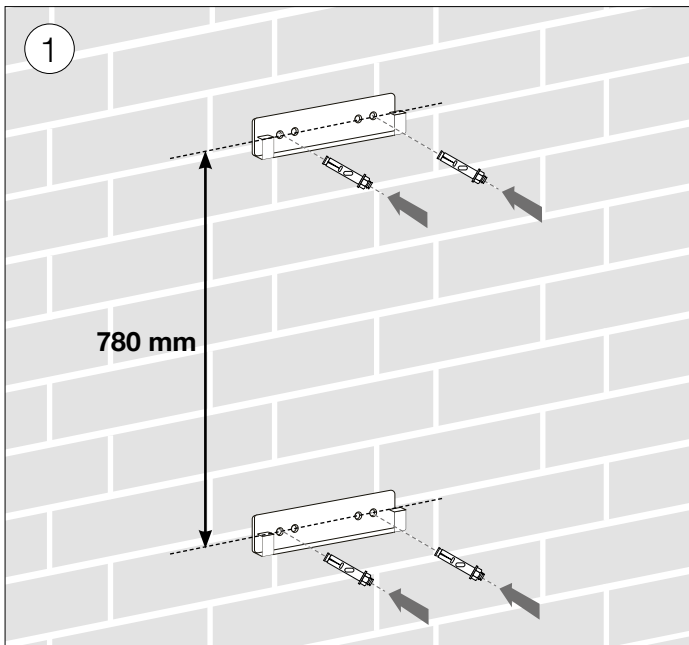

# III/ Electrical connection

## A. Input / Output Connections

1. Lift up cover to reveal the lower section of the box, where the electrical connections are made.

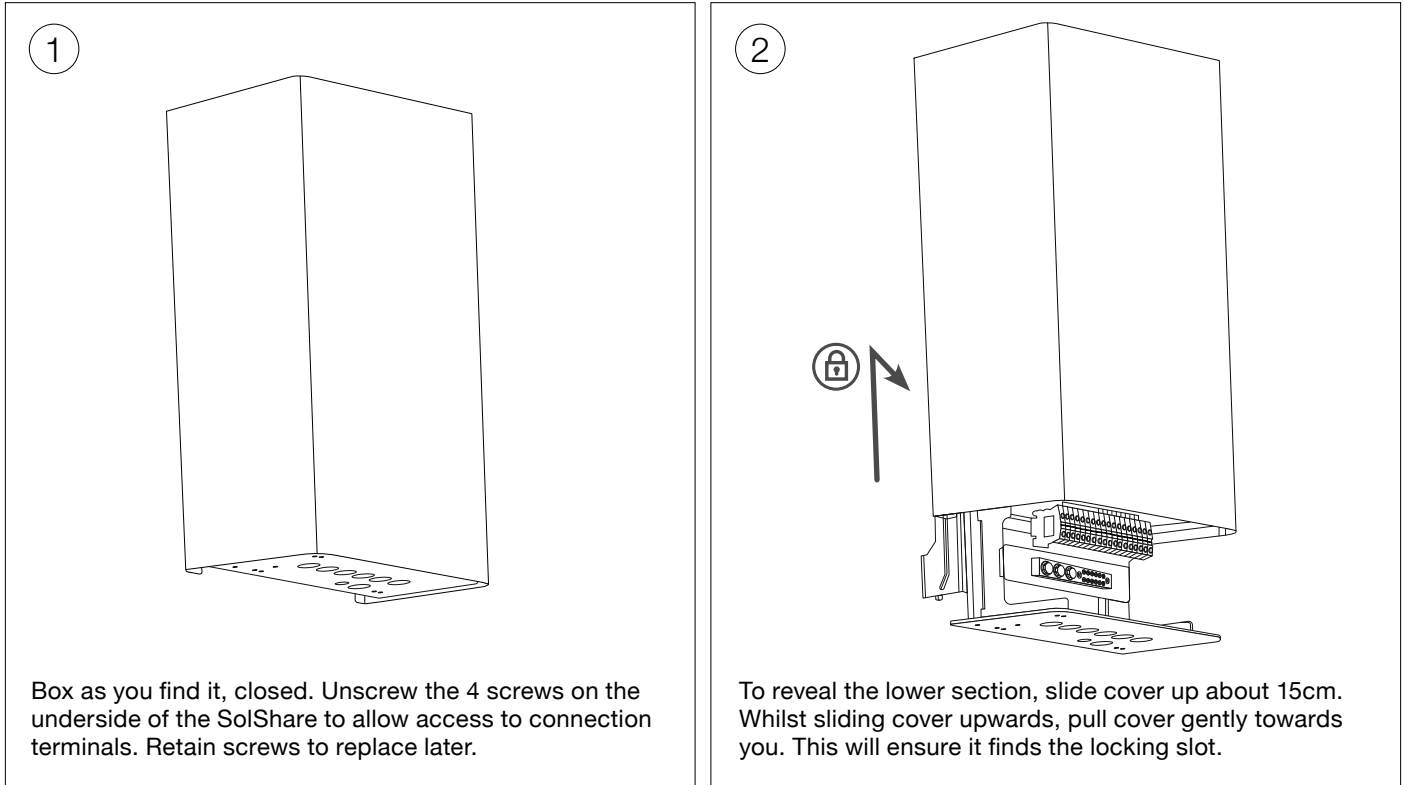

**Important:**

The cover should lock into place when it's pulled up properly. Before beginning wiring, ensure cover is locked in place by pulling down firmly.

To bring cover back to initial position, lift cover upwards and away from you, then allow to slide down back into place.



**Caution:**

Risk of crush hazard if cover dislodged while in service position.

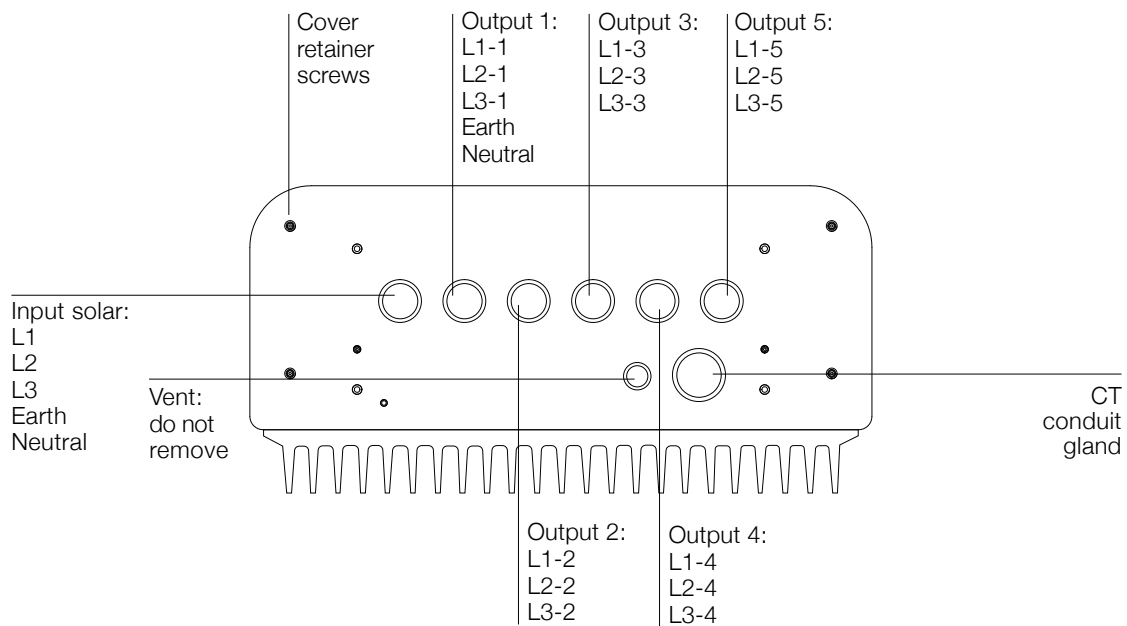

**SolShare underside view**

Each output membrane gland will correspond to the output of 3 single-phase units or 1 three-phase unit. The leftmost membrane gland corresponds to the solar input.

**Cabling**

Connection	Requirement	Recommended Cable
SolShare input	3-phase, earth and neutral	4 core + earth
SolShare output 1	3-phase, earth and neutral	4 core + earth
SolShare outputs 2-5	3-phase only	3 core

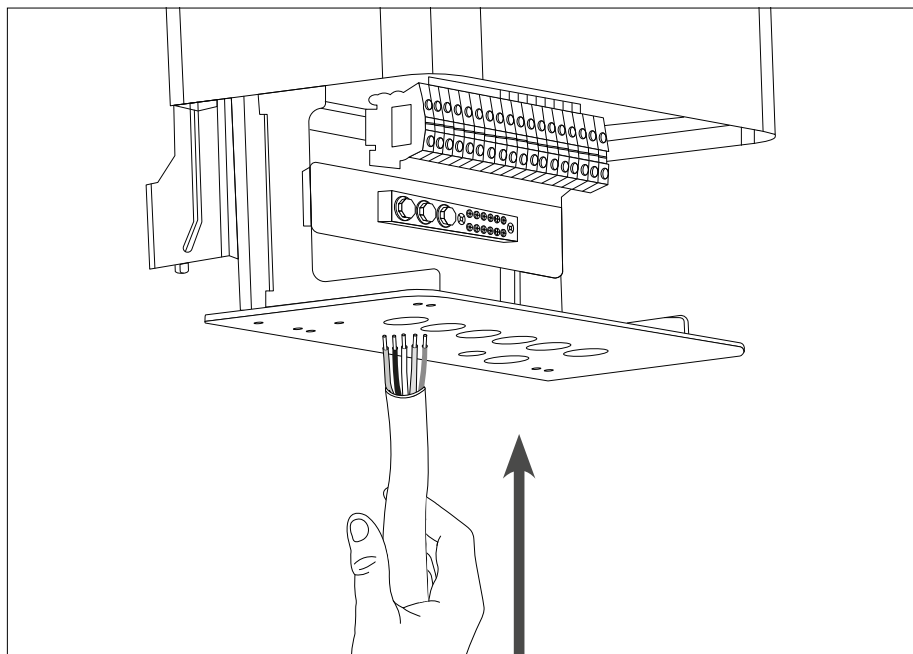

**Area of input / output:**

Cables should be inserted through the appropriate glands, as per the 'SolShare underside view' diagram above.

**Warning:** The SolShare may divert all solar energy to any one unit in a point in time. As a result, all input / output cables should be sized for maximum solar energy output.

**Warning: Outdoor Use requirements**  
 Outdoor installation requires use of minimum IP56 rated liquid tight cable or conduit gland suitable for panel hole dimensions below.  
 Panel thickness: 4mm | Hole diameter: 32mm  
 Replace fitted membrane glands in base panel with conduit fitting

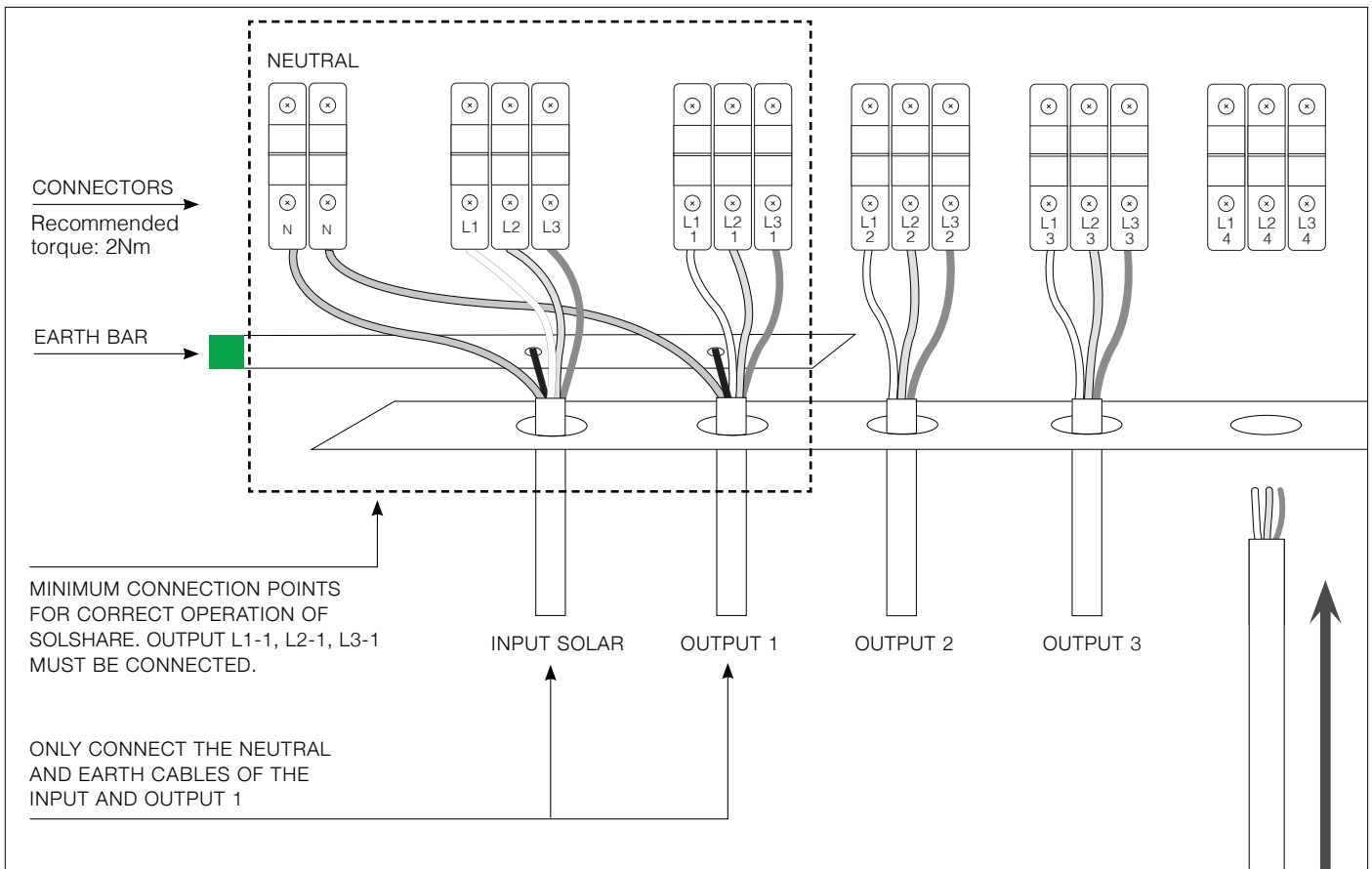

## Input Connection

All wiring is conducted on the AC side of the inverter. The SolShare requires a three-phase, grid-connected inverter to be used in the PV installation. The solar input cable must come from an Inverter Supply Main Switch, ideally located in an accessible location from the main switchboard.

To wire the input cable into the SolShare, the following steps should be taken:

1. Measure out the cable and cut to appropriate length.
2. Strip cable sheath back by approximately 100mm.
3. If outdoors, select appropriate cable/conduit gland and use these to replace membrane glands. Insert 4c+e into SolShare via this cable/conduit glands.
4. Cut and connect earth and neutral from input to their respective connection points.
5. Cut and connect phase cables as per the diagram above.

## Output Connections

**Please refer to your Project Single Line Diagram (SLD) on how to connect the SolShare to the main switchboard.**

Your project SLD should have been designed in accordance to the *SolShare System and SLD Design Guide UK*. If no project SLD exists please contact project owner or system design engineer.

For ease of isolation of the SolShare, it is highly recommended that an enclosure be installed below the SolShare containing SolShare Maintenance Isolators (Grid). As the SolShare is a 3-phase device, it is recommended that these Maintenance Isolators are 3 pole with the same current rating as the Tenancy Main Switches (Inverter Supply).

The outputs from the SolShare must be wired to the SolShare Maintenance Isolators (Grid). The outputs of the SolShare Maintenance Isolators (Grid) must be wired to their respective Tenancy Main Switch (Inverter Supply).

Ensure each cable is labelled with the tenancy number. This will help later on in the installation when wiring the current transformers to each unit.

### Follow these steps to complete the output wiring:

1. Complete the Unit Connected column of the Commissioning Document on page 6, allocating a SolShare output to the unit/apmt number that will be connected.
2. Cut output power cables to appropriate length to reach from SolShare Maintenance Isolators (Grid) to SolShare. Label both ends of these cables with the tenancy number.
3. Run cables between SolShare and SolShare Maintenance Isolators (Grid). Terminate cables to appropriate SolShare output connectors as per the configuration in step 1. Connect the neutral from Output 1 to the SolShare. Use two of the earth screws provided with the SolShare to secure the earth connection of Output 1 to the SolShare's earth bar. The remaining earth screws can be discarded or screwed into the Earth bar.
4. Cut the power cables to appropriate length to run from the SolShare Maintenance Isolators (Grid) to the Tenancy Main Switches (Inverter Supply) in the Main Switchboard. Run and terminate these cables, ensuring an earth and neutral connection on Output 1.



#### **Warning:**

- Ensure the phase of the solar supply correctly matches the phase of the unit's supply from the grid.
- Additional circuit breakers must be sized to perform overload protection for SolShare output cables.
- The solar system max output must be less than the main circuit breaker rating of every connected unit.
- The neutral for the SolShare must be wired directly to the main neutral bar inside the main switchboard.
- Point of connection of solar should be on the grid side of tenancy main switch unless specified otherwise by your Project SLD.
- Note that use of a SolShare connection on the grid side of the main overcurrent protection is the preferred arrangement and if connecting on the load side, the Line and Neutral conductors must be up-rated to allow for the potentially higher currents.



#### **Important:**

It is recommended to label both ends of each cable with the appropriate tenancy name (e.g. Unit 21) and SolShare output name (e.g. L1-1 or L3-4, etc.) to ensure the correct cable is wired into the correct tenancy in the main switchboard.



#### **Important:**

For maintenance and troubleshooting purposes, it is requested to write the tenancy names corresponding to each output on the bottom plate of the SolShare (with permanent marker).



#### **Important:**

SolShare must have output connection (with grid connection) to L1-1, L2-1, L3-1 for correct operation. If possible, wire these to common power connection.



#### **Important:**

Check the order of the SolShare outputs carefully. The SolShare terminal block is configured to wire in the order L1-1, L2-1, L3-1, L1-2, L2-2, L3-2, L1-3, ... etc. Ensure the connections from the Tenancy Main Switches (Inverter Supply) via any SolShare Maintenance Isolators (Grid) are connected in this order. Ensure the switches are labeled clearly and logically.



#### **Warning:**

Only **one** neutral and ground shall be wired out of the SolShare, as shown in the diagram on page 14. Output neutral and ground must be wired to main neutral bar and main earth bar respectively, located in the main switchboard.

## B. Running current transformer tails

1. Run CT conduit from SolShare to main switchboard (the CT conduit gland is the pre-installed CT conduit gland on the underside of the SolShare - see the underside view diagram on p. 13 to ascertain where the CT conduit gland is).
2. Look for labels on current transformers and current transformer tails. Ensure these match the corresponding tenancy.
3. Run tails of CTs from main switchboard to SolShare through conduit.

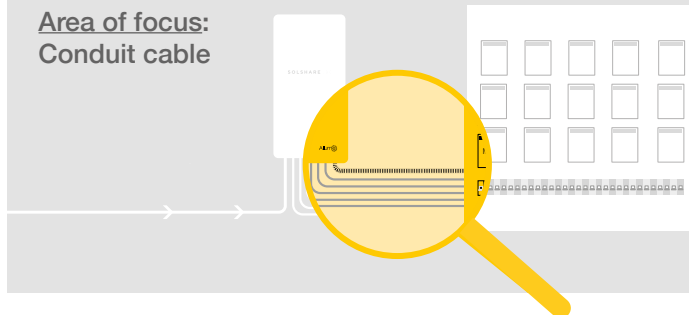

### **Important:**

If you are using the standard 75A CTs provided with the SolShare, their 10m tails cannot be extended.

If you require tail lengths of more than 10m, an additional upgraded CT set should have been ordered at the time of ordering the SolShare. Please call Allume on the phone number provided on the back page of this manual to order the upgraded CT kit.

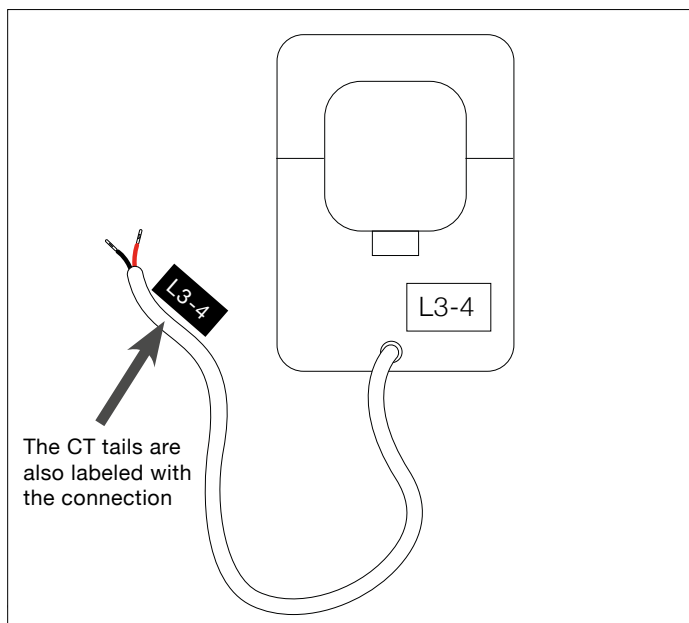

### **Important:**

If you are using the upgraded CT set, these come with 10m tails but can be extended to a total of up to 50m. The tail extension can be done for each CT separately using the following recommended parts:

- Butt splice connector (appropriate size for cable)
- Twisted shield cable, minimum 24 AWG size (to the length required on top of 10m to make the run between SolShare and main switchboard)

## Current transformers to SolShare connections

Wiring tails to Solshare:

1. Connect the CT cabling to the CT connector block, as per the diagram to the right. To do this:
  - Push the orange tab in and hold.
  - Feed the CT cable into the hole.
  - Once inserted, release the orange tab.
  - Confirm cable is secure by giving it a gentle tug.
2. Repeat for all CT cables of the L1 phase.
3. Repeat steps 1 & 2 for L2 and L3 phase connector blocks.
4. Plug each CT connector block into the corresponding socket of the SolShare.

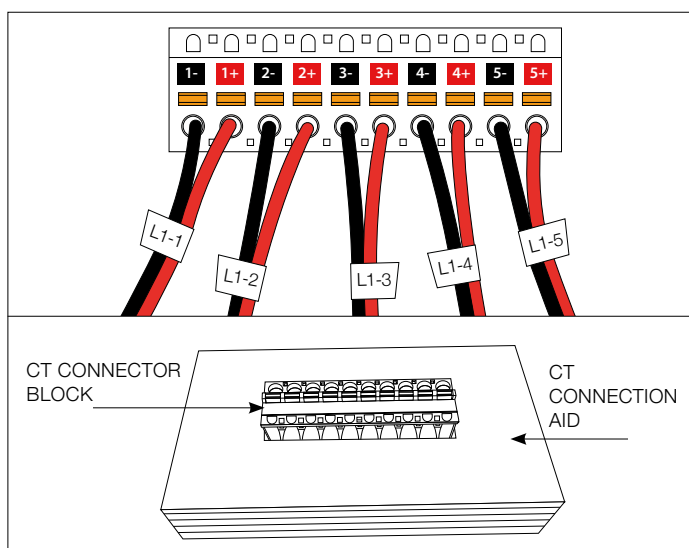

### **Important:**

Make sure colours and orientation of connectors are identical to the image above. To ensure you are positioning them correctly, check that the orange tabs are above your plugged in cables, and labels read as above.



### **Important:**

The SolShare has come with a CT connection aid. Place the CT connector into the connection aid to help with the termination of the CT tails.



## Current transformer clipping

Clipping the current transformers onto the service side cable:

1. Match the labelled CTs with their corresponding labelled service supply cable.
2. Confirm correct polarity of the CT by ensuring the arrow on the CT head matches the current flow direction on the service supply cable.
3. Clip CT over service supply cable.

 **Important:** Make sure that each CT is clipped to the corresponding unit.

 **Important:** The CT must be connected on the service side of the point of connection of solar supply, as per diagram.

\* The point of connection of the solar may appear different in your case depending on the Project SLD. In any case, the CT must be on the line side of the point of connection of the solar supply.

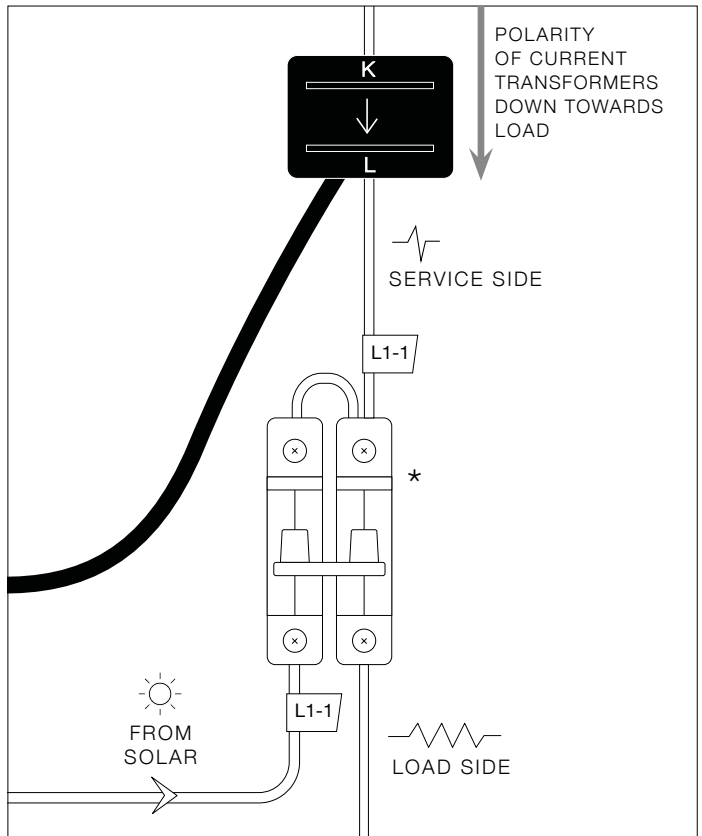

## C. Labelling

The SolShare comes with a Label Pack for you to use where appropriate. Other labelling will also be required based on your installation and local requirements. For more information, refer to the *SolShare Labelling Advice* document. Please refer below for information about SolShare-specific labelling.

Leave a copy of the Project SLD at site to provide guidance to any other electrician working on the switchboard.

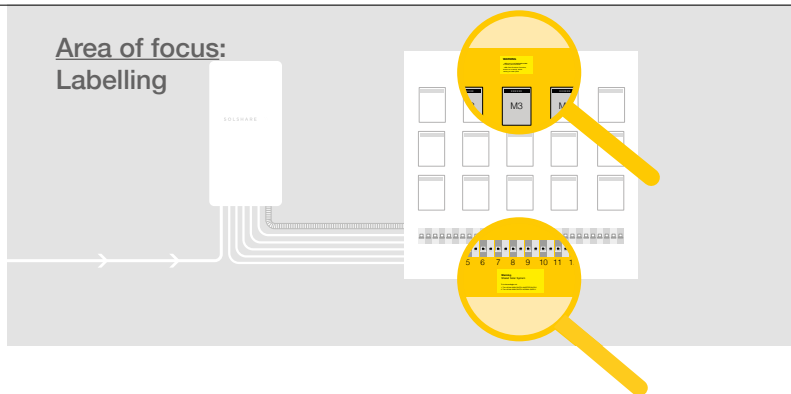

### Line side wiring

#### WARNING

Solar wired on the **line/service side** of Tenancy Main Switches

Follow Solar Shutdown Procedure, located on inverter(s), before working on meter panel

**NOTE:** This must be visible from all meters (contact Allume if additional labels are required). Do not apply this label if SolShare connections have been made on the load side of the Main Switch (Normal Supply). Instead, use a standard multiple supplies warning label.

### Warning tenancy shutdown

#### Warning Shared Solar System

To isolate a **single** unit:

1. Turn off their TENANCY MAIN SWITCH INVERTER SUPPLY
2. Turn off their TENANCY MAIN SWITCH NORMAL SUPPLY

**NOTE:** This must be visible from all Tenancy Main Switches (contact Allume if additional labels are required).

### Add these additional labels as suitable:

- SolShare Maintenance Isolator (Inverter) label
- SolShare Maintenance Isolator (Grid) labels
- Tenancy Main Switch (Inverter Supply) labels
- Tenancy Main Switch (Normal Supply) labels (not provided with SolShare)

# IV/ Commissioning

## A. Preparing the SolShare



### **Important:**

- Before commissioning, re-check all CTs and output cables are connected as per their labels.
- Record connection information on commissioning notes page, you will need to enter this while commissioning the unit after the cover is closed.



### **Warning:**

When closing the cover of the SolShare, ensure the seals are oriented correctly. This will ensure an appropriate seal for the IP56 rating of the SolShare. See the graphics to the right showing correct orientation of the seals.

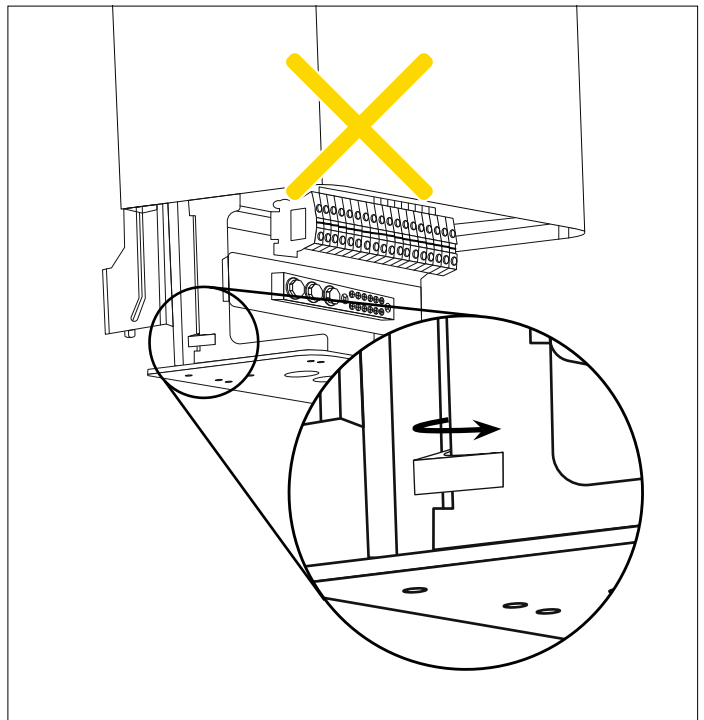
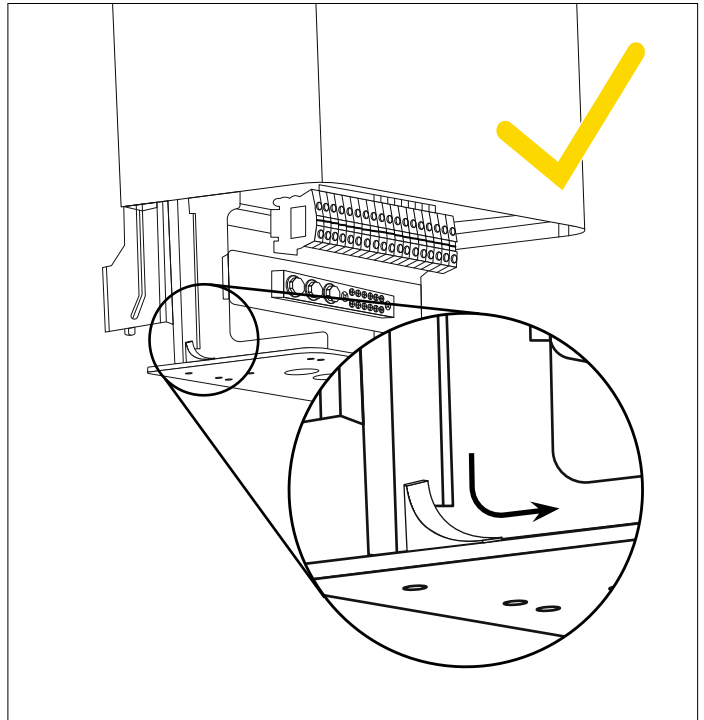

To power on the SolShare:

1. Pull down cover of SolShare, ensuring the seals are oriented correctly. Fasten shut by replacing the 4 screws on the underside of the SolShare, that were removed in section III/A.1.

### **Maximum torque for cover fasteners is 1.5Nm**

2. Turn on Inverter AC Isolator located next to inverter
3. Turn on Inverter Supply Main Switch
4. Ensure Main Switches (Normal Supply) are on
5. Turn on Main Switches (Inverter Supply)

To connect the SolShare to Wi-Fi (must be done within 5 mins of powering on the SolShare):

1. Using a laptop or phone (your device), connect your device to the SolShare SSID (this will appear as SolShare3P\_35A\_XXXX where XXXX is the last 4 digits of the SolShare serial number).
2. Open an internet browser on your device and navigate to 192.168.4.1.
3. Once the page loads in the browser, enter the SSID and password of the Wifi network that you want the SolShare to connect to.
4. Once you see a confirmation page in the browser, wait for the SolShare to reboot.
5. Disconnect your device from the SolShare SSID and reconnect it to the internet in preparation for the commissioning steps below.

If you are having troubles with this process or need more detail, consult the *How to set-up/change Wi-Fi credentials* document.

## B. Commissioning the SolShare

1. To commission the SolShare, scan the QR code on the right side of the SolShare or go to <https://commissioning.allumeenergy.com> to access the SolShare Commissioning App.
2. Follow the steps in the Commissioning App to commission each SolShare. The *Commissioning App Guide* provides more information on the commissioning process. NOTE: The SolShare requires a fully operational inverter in order to complete commissioning. During the SolShare commissioning process, you will be prompted to commission the inverter. Please make sure that the inverter is ready to be commissioned prior to starting the commissioning process for the SolShare.
3. If you experience issues with the commissioning process contact Allume Service on +44 20 3239 0409 or [support@allumeenergy.com](mailto:support@allumeenergy.com)

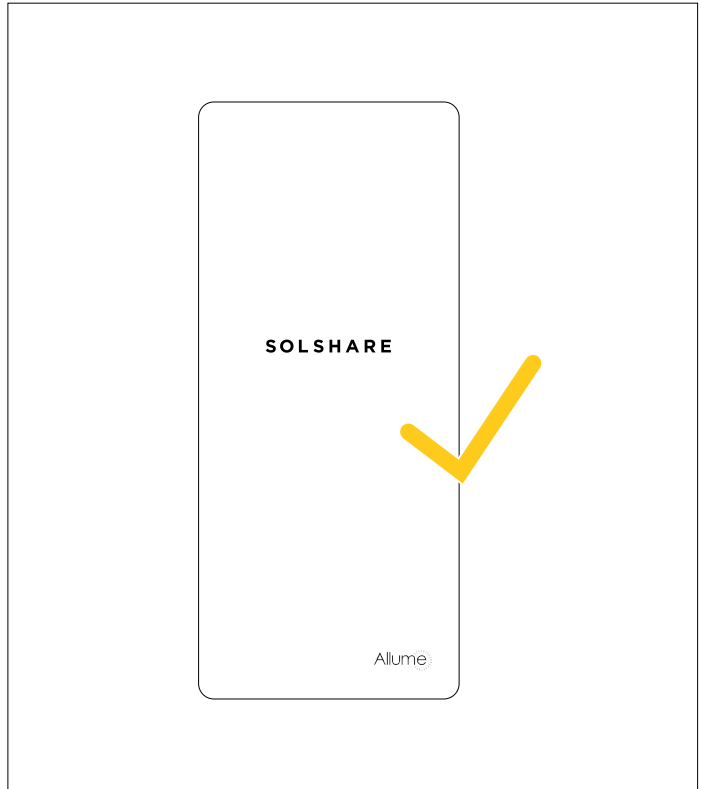



This manual is intended for installations in the **UK**.  
Specifications are subject to changes without advanced notification.

For the most up to date documentation, visit **[www.allumeenergy.com](http://www.allumeenergy.com)**

Allume Energy Ltd.  
[www.allumeenergy.com](http://www.allumeenergy.com)  
[info@allumeenergy.com](mailto:info@allumeenergy.com)  
+44 20 3239 0409